

# 8350-1 Temperature Transmitter



3-8350.090-1

E-8/03 English



## CAUTION!

- Remove power to unit before wiring input and output connections.
- Follow instructions carefully to avoid personal injury.

## Contents

1. Installation
2. Specifications
3. Electrical Connections
4. Menu Functions



## 1. Installation

ProcessPro transmitters are available in two styles: panel mount and field mount. The panel mount is supplied with the necessary hardware to install the transmitter. This manual includes complete panel mounting instructions.

Field mounting requires one of two separate mounting kits. The 3-8052 integral kit joins the sensor and instrument together into a single package. The 3-8050 Universal kit enables the transmitter to be installed virtually anywhere.

Detailed instructions for integral mounting or other field installation options are included with the 3-8052 Integral kit or the 3-8050 Universal kit.

### 1.1 Panel Installation

1. The panel mount transmitter is designed for installation using a 1/4 DIN Punch. For manual panel cutout, an adhesive template is provided as an installation guide. Recommended clearance on all sides between instruments is 1 inch.
2. Place gasket on instrument, and install in panel.
3. Slide mounting bracket over back of instrument until quick-clips snap into latches on side of instrument.
4. To remove, secure instrument temporarily with tape from front or grip from rear of instrument. **DO NOT RELEASE.** Press quick-clips outward and remove.

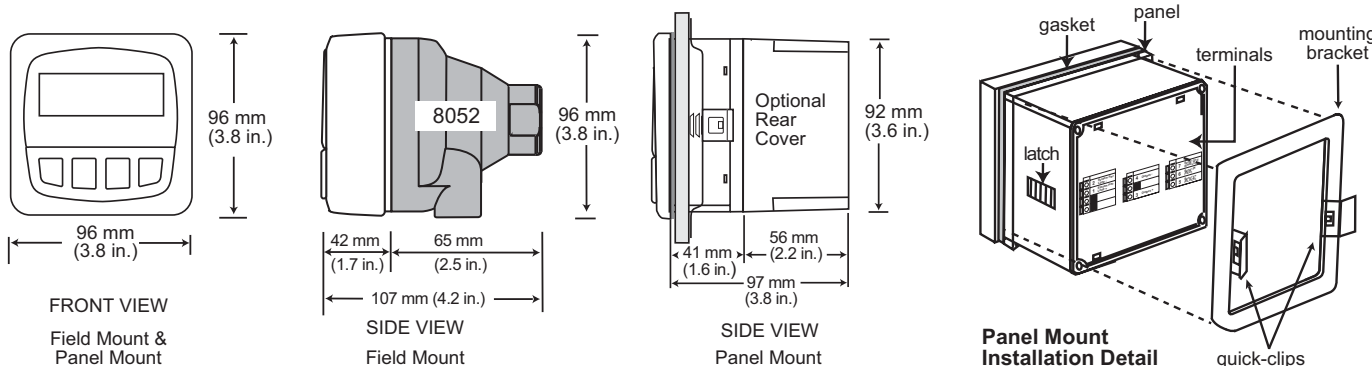

## 2. Specifications

### General

- Compatibility: +GF+ SIGNET 2350-1/ -2 Temperature sensors
- System accuracy:  $\pm 0.5^\circ\text{C}$  with 2350 sensors

### Enclosure:

- Rating: NEMA 4X/IP65 front
- Case: PBT
- Panel case gasket: Neoprene
- Window: Polyurethane coated polycarbonate
- Keypad: Sealed 4-key silicone rubber
- Weight: Approx. 325g (12 oz.)

### Display:

- Alphanumeric 2 x 16 LCD
- Display update rate: 1 second
- Contrast: User selected, 5 levels

### Electrical

- Power: 12 to 24 VDC  $\pm 10\%$  regulated, 21 mA max current
- Current output: 4 to 20 mA, isolated, fully adjustable and reversible
- Max loop impedance: 50 $\Omega$  max. @ 12V, 325 $\Omega$  max. @ 18V, 600 $\Omega$  max. @ 24V
- Update rate: 100 ms
- Output accuracy:  $\pm 0.03$  mA

### Open-collector output:

- Optically isolated, 50 mA max. sink
- 30 VDC maximum pull-up voltage.
- Programmable for:
  - Hi, Lo with adjustable hysteresis
  - Pulse operation (maximum pulse rate: 400 pulses/min).

### Environmental

- Operating temperature:  $-10$  to  $70^\circ\text{C}$  (14 to  $158^\circ\text{F}$ )
- Storage temperature:  $-15$  to  $80^\circ\text{C}$  (5 to  $176^\circ\text{F}$ )
- Relative humidity: 0 to 95%, non-condensing
- Maximum altitude: 2000 m (6562 ft)
- Insulation category: II
- Pollution degree: 2

### Standards and Approvals:

- CSA, CE, UL listed
- Immunity: EN50082-2
- Emissions: EN55011 Class B
- Manufactured under ISO 9001 and ISO 14001

### 3. Electrical Connections



**Caution:** Failure to fully open terminal jaws before removing wire may permanently damage instrument.

#### Wiring Procedure

1. Remove 0.5 - 0.625 in. (13-16 mm) of insulation from wire end.
2. Press the orange terminal lever downward with a small screwdriver to open terminal jaws.
3. Insert exposed (non-insulated) wire end in terminal hole until it bottoms out.
4. Release orange terminal lever to secure wire in place. Gently pull on each wire to ensure a good connection.

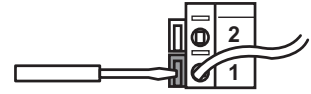

#### Wiring Removal Procedure

1. Press the orange terminal lever downward with a small screwdriver to open terminal jaws.
2. When fully open, remove wire from terminal.

#### Wiring Tips:

- Do not route sensor cable in conduit containing AC power wiring. Electrical noise may interfere with sensor signal.
- Routing sensor cable in grounded metal conduit will help prevent electrical noise and mechanical damage.
- Seal cable entry points to prevent moisture damage.
- Only one wire should be inserted into a terminal. Splice double wires outside the terminal.
- The cable length from the sensor to the transmitter must not exceed 400 ft. (122 m)
- For best performance, ground the sensor SHIELD wire to a local earth ground at a point near the sensor. (Experiment with connecting the sensor shield wire to different local ground points to identify best signal quality.)

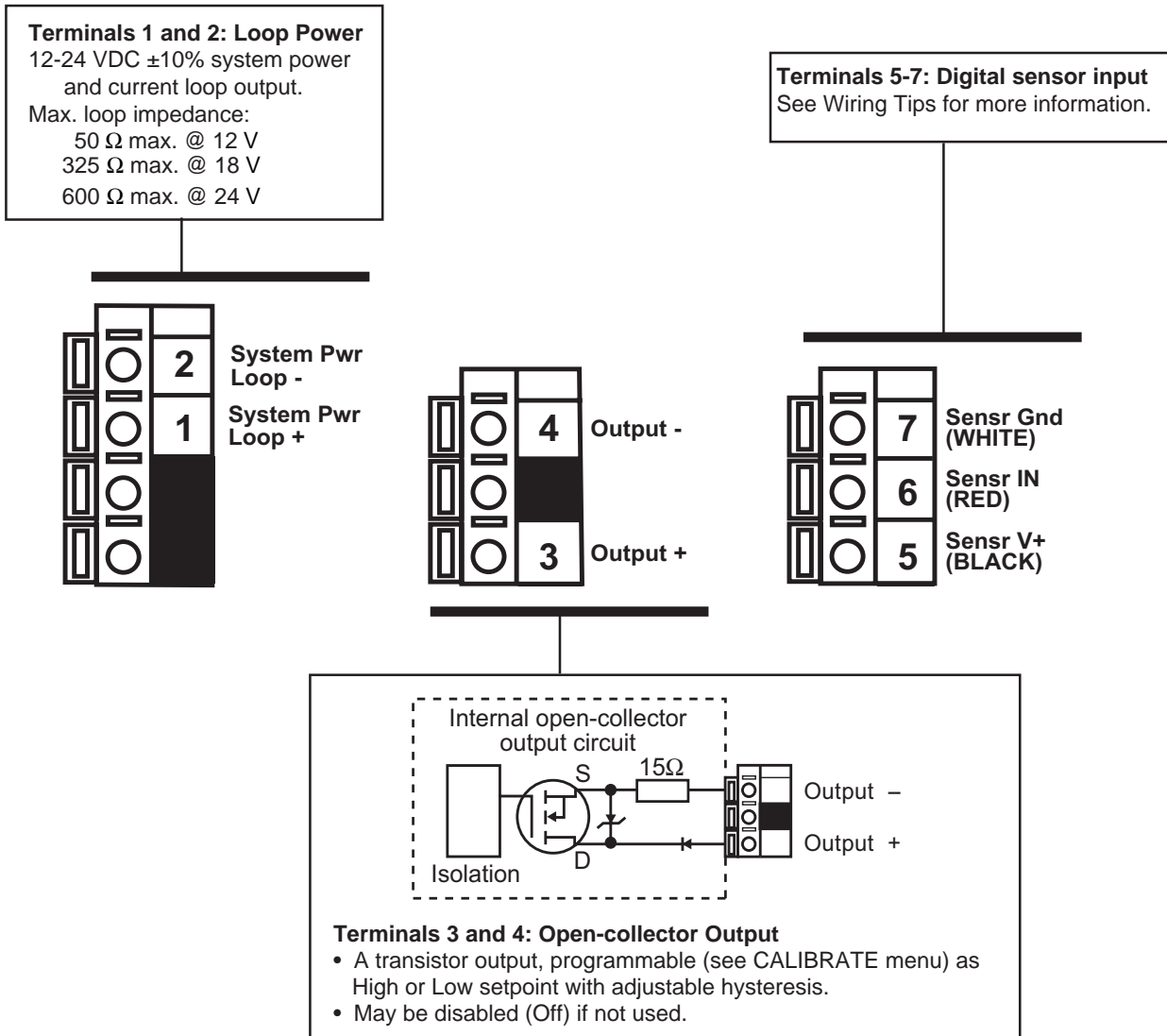

### 3.1 Sensor Input Connections



### 3.2 System Power/Loop Connections

Stand-alone application, no current loop used

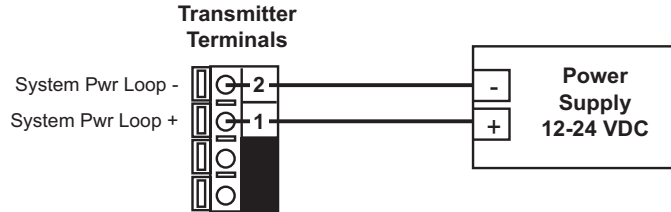

Connection to a PLC/Recorder, separate supply

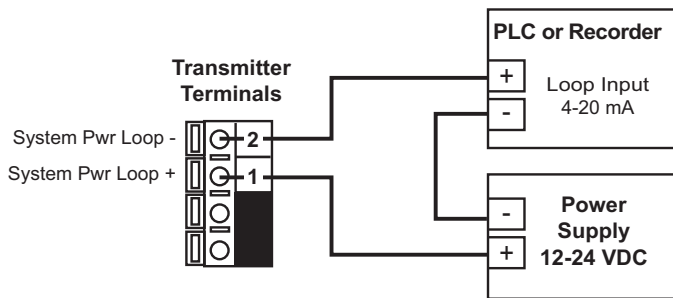

Connection to a PLC with built-in power supply

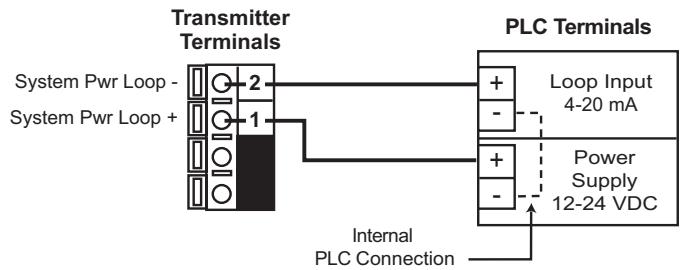

Example: Two transmitters connected to PLC/Recorder with separate power supply

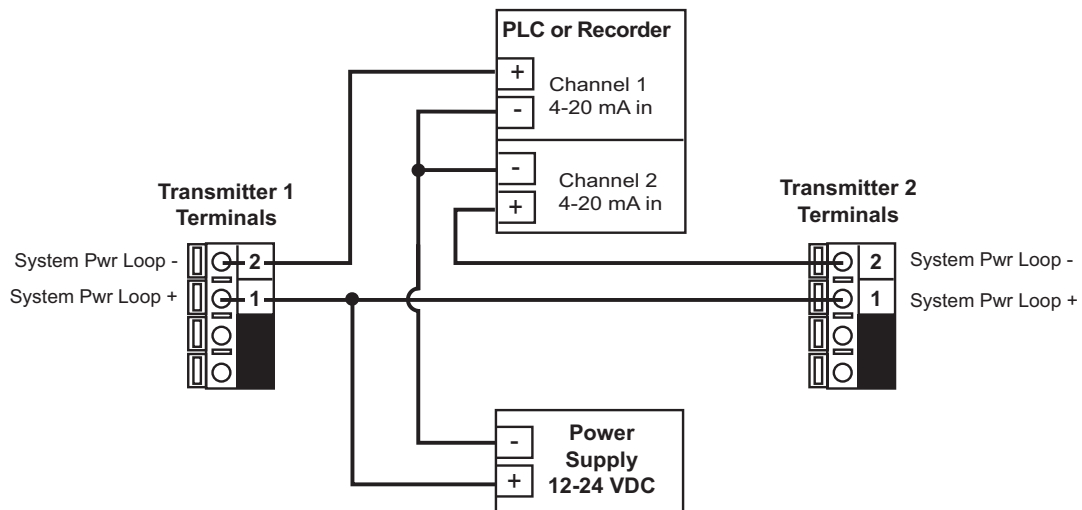

### 3.3 Open Collector Output

The Open Collector output can be used as a switch that responds when the process value moves above or below a setpoint, or it can be used to generate a pulsing signal with a rate proportional to the process value.



- **Low:**

Output triggers when process variable is less than the setpoint. The output will relax when the process variable moves above the setpoint plus the hysteresis value.

- **High:**

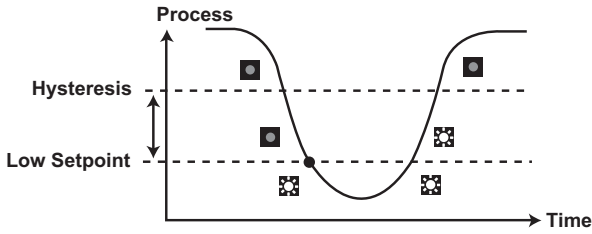
Output triggers when process variable is greater than the setpoint. The output will relax when the process variable moves below the setpoint plus the hysteresis value.



Relay energized   
Relay relaxed 

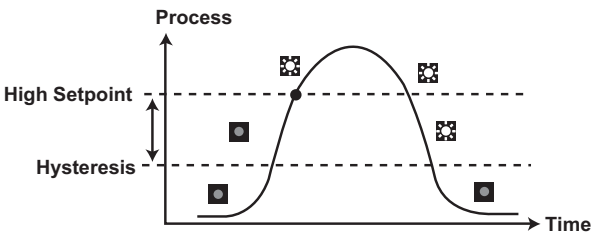

- **Proportional Pulsing**

The Open Collector output will generate a 100 mS pulse at the rate defined by settings in the CALIBRATE menu (see page 6)

In the example below:

- The output will be 0 pulses/min. at temperatures less than 5°.
- The output will be 50 pulses/min. at 7.5°.
- The output will be 100 pulses/min. at temperatures above 10°.

The starting point, endpoint and maximum pulse rate are selectable in the menu.

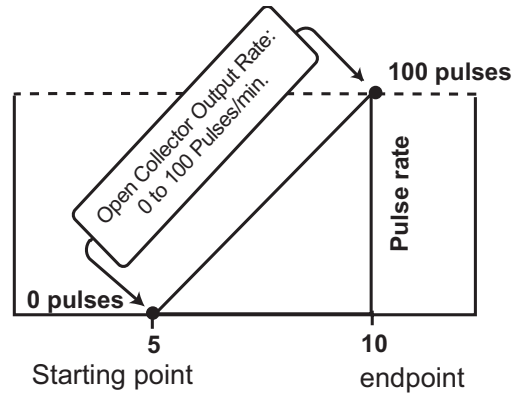

## VIEW menu

- During normal operation, ProcessPro displays the VIEW menu.
- When editing CALIBRATE or OPTIONS menus, ProcessPro returns to the VIEW menu if no activity occurs for 10 minutes.
- To select a VIEW display, press the UP or DOWN arrow keys. The selections will scroll in a continuous loop.
- Changing the display selection does not interrupt system operations.
- No key code is necessary to change display selection.
- Output settings cannot be edited from the VIEW menu.

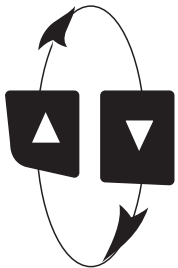

### View Menu

Display	Description
Temperature: 28.7°C	Monitor the Temperature input from the sensor. This is the permanent display.

The VIEW displays below are temporary. The permanent display will return after 10 minutes

Loop Output: 12.00 mA	Monitor the 4-20 mA Loop output.
Last Cal 06-30-03	Monitor date for scheduled maintenance or date of last calibration.

# ProcessPro Editing Procedure:

## Step 1. Press and hold ENTER key:

- 2 seconds to select the CALIBRATE menu
- 5 seconds to select the OPTIONS menu.

## Step 2. The Key Code is UP-UP-UP-DOWN keys in sequence.

- After entering the Key Code, the display will show the first item in the selected menu.

## Step 3. Scroll menu with UP or DOWN arrow keys.

## Step 4. Press RIGHT ARROW key to select menu item to be edited.

- The first display element will begin flashing.

## Step 5. Press UP or DOWN keys to edit the flashing element.

- RIGHT ARROW key advances the flashing element.

## Step 6. Press ENTER key to save the new setting and return to Step 3.

### Notes on Step 1:

- The View Menu is normally displayed.
- The CALIBRATE and OPTIONS menus require a KEY CODE.

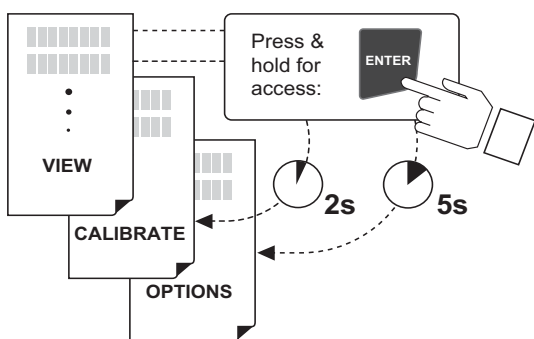

### Notes on Step 2:

If no key is pressed for 5 minutes while display is showing "Enter Key Code", the display will return to the VIEW menu.

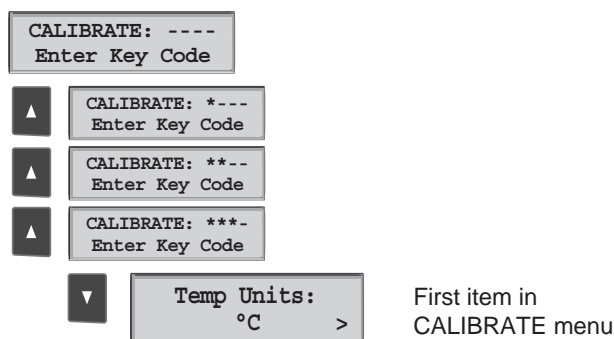

### Notes on Steps 3 and 4:

- Refer to pages 6 and 7 for complete listing of menu items and their use.
- From the Step 3 display, pressing the UP and DOWN keys simultaneously will return the display to the VIEW menu.
- If no key is pressed for 10 minutes, display will also return to the VIEW menu.



**Step 3: Finished Editing?**

Press the UP and DOWN keys simultaneously after saving the last setting to return to normal operation.

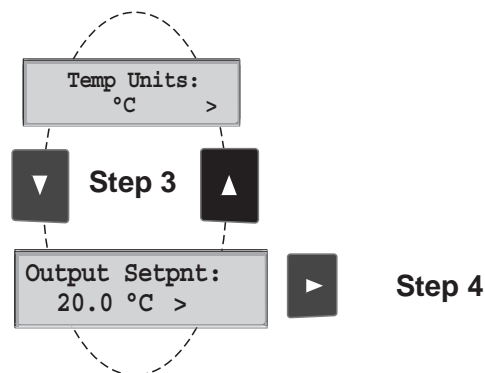

### Notes on Steps 5 and 6:

- All output functions remain active during editing.
- Only the flashing element can be edited.
- RIGHT ARROW key advances the flashing element in a continuous loop.
- Edited value is effective immediately after pressing ENTER key.
- If no key is pressed for 10 minutes unit will restore the last saved value and return to step 3.
- Step 6 (pressing ENTER key) always returns you to Step 3.
- Repeat steps 3-6 until all editing is completed.

**Step 5: Made an Error?**

Press the UP and DOWN keys simultaneously while any element is flashing. This will recall the last saved value of the item being edited and return you to Step 3.



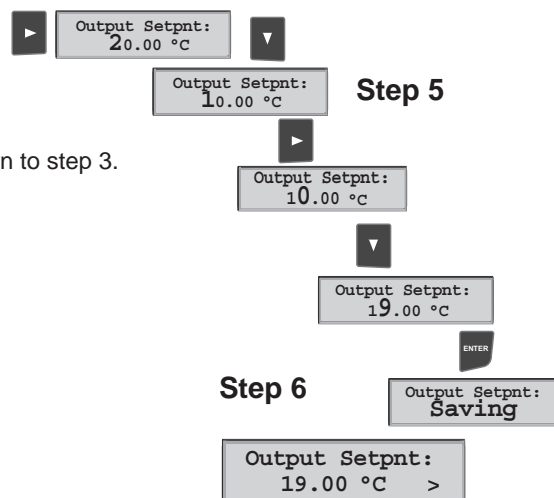

## Calibrate Menu

Display (Factory settings shown)	Description
Temp Units: °C >	Select Temperature units: °C or °F
Set: Temperature >	Provides a maximum 20°C offset to match 8350 to external reference. Enter "-999" to restore the original Factory calibration value
Loop Range: °C 0.0 → 100.0 >	Set the minimum and maximum temperature range for the 4-20 mA loop output.
Output Mode: Low >	Select the desired mode of operation for the open-collector output: OFF, LOW, HIGH or PULSE.
Output Setpnt: 25 °C >	If you select LOW or HIGH mode, the Open Collector Output will be deactivated when the temperature reaches this value. Be sure to modify this setting if you change the Temperature Units.
Output Hys: °C >	The Open Collector Output will be deactivated at setpoint ± Hysteresis (+ or - according to High or Low selection).
Output Range: 25.0 → 45.0 >	If the output is in PULSE mode, set the start and end point of the range and also set the maximum pulse rate. (The maximum PULSE rate setting is 400 pulses per minute.)
Output PlsRate: 120 Pulses/Min >	The combined Output Range and Pulse rate settings shown here indicate: "Start pulsing when the process value is 25° and increase the pulse rate up to the maximum of 120 pulses per minute when the process value reaches 45°"
Last Cal 06-30-01 >	Use this "note pad" to record important dates, such as annual recertification or scheduled maintenance.

## Options Menu

Display (Factory settings shown)	Description
<b>Contrast:</b> 3 >	Adjust the LCD contrast for best viewing. A setting of 1 is lower contrast, 5 is higher. In general, select lower contrast if the display is in warmer ambient surroundings.
<b>Output Active:</b> Low >	Active HIGH: This setting is used to turn a device (pump, valve) ON at the setpoint. Active LOW: This setting is used to turn a device OFF at the setpoint.
<b>Averaging:</b> Off >	OFF provides the most instantaneous response to changes in temperature. Select LOW (4 sec) or HIGH (8 sec) averaging if your process experiences frequent or extreme fluctuations in temperature.
<b>Loop Adjust:</b> 4.00 mA >	Adjust the minimum and maximum current output. The display value represents the precise current output. Adjustment limits: • 3.80 mA < 4.00 mA > 5.00 mA • 19.00 mA < 20.00 mA > 21.00 mA Use this setting to match the system output to any external device.
<b>Loop Adjust:</b> 20.00 mA >	
<b>Test Loop:</b> >	Press UP and DOWN keys to manually order any output current value from 3.6 mA to 21.00 mA to test the output loop.
<b>Test Output:</b> >	Press UP and DOWN keys to manually toggle the Open Collector output state.

## Troubleshooting

Display Condition	Possible Causes	Suggested Solutions
"Check Sensor?"	<ul style="list-style-type: none"> <li>• Sensor not wired properly</li> <li>• Defective Sensor</li> </ul>	<ul style="list-style-type: none"> <li>• Correct Sensor wiring</li> <li>• Replace defective sensor</li> </ul>
"Too Much Error CHECK SENSOR"	The value entered in the "Set Temperature" field is greater than 20°C (34°F) deviation from sensor input. (The 8350 allows a maximum of 20°C offset)	<ul style="list-style-type: none"> <li>• Confirm calibration value</li> <li>• Replace defective sensor</li> </ul>
"Reset to Factory Calibration"	Value in SET TEMPERATURE field is -999	Entering "-999" in this field will remove all user calibration input and restore the factory value to the "Set Temperature" field only.
Relay is always activated	Hysteresis value too large	Change the hysteresis value in the Calibrate menu.
"Value must be 400 or less"	Value entered in Output PlsRate field is greater than 400	Select a maximum pulse rate less than 400 pulses per minute.

## Ordering Information

Mfr. Part No.	Code	Description
3-8350-1	159 000 192	Temperature transmitter Field mount
3-8350-1P	159 000 193	Temperature transmitter Panel mount
3-8350-2	159 000 194	Temperature transmitter Field mount with relays
3-8350-2P	159 000 195	Temperature transmitter Panel mount with relays
3-8350-3	159 000 196	Temperature transmitter Field mount with dual input/output
3-8350-3P	159 000 197	Temperature transmitter Panel mount with dual input/output

## Accessories

Mfr. Part No.	Code	Description
3-8050	159 000 184	Universal mounting kit
3-8052	159 000 188	3/4" Integral mounting kit
3-8052-1	159 000 755	3/4" NPT mount junction box
3-8050.395	159 000 186	Splashproof rear cover
3-8050.396	159 000 617	RC Filter kit (for relay use)
3-0000.596	159 000 641	Heavy duty wall mount bracket
3-5000.598	198 840 225	Surface Mount Bracket
3-9000.392	159 000 368	Liquid tight connector kit for rear cover (includes 3 connectors)
3-9000.392-1	159 000 839	Liquid tight connector kit, NPT (1 piece)
3-9000.392-2	159 000 841	Liquid tight connector kit, PG13.5 (1 piece)



Signet Scientific Company, 3401 Aerojet Avenue, El Monte, CA 91731-2882 U.S.A. • Tel. (626) 571-2770 • Fax (626) 573-2057  
For Worldwide Sales and Service, visit our website: [www.gfsignet.com](http://www.gfsignet.com) • Or call (in the U.S.): (800) 854-4090

