

# Mobrey MSP900SH

## Ultrasonic liquid level transmitter



- ▶ 2 Wire loop powered
- ▶ 12m Operating range
- ▶ 4-20mA / HART
- ▶ Sealed IP68
- ▶ ATEX IS certified
- ▶ CSA Zone zero certified
- ▶ Measures
  - Level
  - Contents
  - Flow

### Introduction

The MSP900SH is a sealed 4-20mA loop powered level transmitter specifically designed for use in Waste Water and Effluent Treatment Plant on aqueous applications. ATEX certified Intrinsically Safe for use in Zone 0 areas, the rugged UPVC transmitter is factory fitted with up to 50m of two core cable for simple low cost installation in sumps, wet-wells and over open channel flow structures.

The MSP900SH can be connected directly to a plant control system or used with a Mobrey MCU900 Control unit which gives flexible and comprehensive user programmable control functionality.

Calibration and programming are usually accomplished through the Mobrey MCU900 Control unit, or alternatively, if the MSP900SH transmitter is connected directly to the plant control system, using a HART compatible programmer or software tool.

The MSP900SH transmitter replaces the popular MSP90 transducer, and may be connected to existing MSP90 Control units using the 4-20mA input terminals.

### Transmitter features and application

- ▶ 4-20mA output proportional to measured or calculated value.
- ▶ Factory sealed IP68 for use in wet-wells and sumps up to 12m deep. Option of submersion shield to protect transmitter face from contamination if well is liable to flooding.
- ▶ Rugged all UPVC construction ideal for application on exposed sites such as reservoirs, rivers or remote works.
- ▶ Supplied complete with 316SS mounting bracket and 1" lock nut to facilitate fast and low cost installation using either rigid or suspension mounting methods.
- ▶ ATEX Intrinsically Safe certification allows unrestricted use in hazardous areas, including Zone 0, without the need for expensive cable protection and installation.
- ▶ May be programmed to calculate contents or flow in accordance with BS3680 Pt.4, ISO1438/1 and ISO4359 using pre-programmed algorithms or a user-defined look-up table.
- ▶ On-board HART digital communications allows programming, remote interrogation and diagnostics.
- ▶ Use two MSP900 transmitters to monitor differential level across a screen, automating screen cleaning cycles, or on two flow channels to sum total flow into or out of a works.



## Technical specification

Operating		Electrical	
Range	0.3 to 12m	Supply voltage	12V dc to 40V dc (transmitter in non-hazardous area) 12V dc to 30V dc (transmitter in hazardous area, supplied from a protected supply)
Accuracy*	+/- 0.25% of measured range (>1.0 to 12.0m)	Output	4–20mA HART Digital comms (Rev.5)
Resolution	1mm	Cable size	Overall diameter 4.0mm, 2 cores each 0.22mm <sup>2</sup>
Pressure	0bar to 3bar	Cable length	3,20 or 50m to order. May be extended or shortened on site.
Temperature	-40°C to +60°C wetside -40°C to +60°C ambient	Cable resistance	0.1 Ohm/m
Environmental	Suitable for indoor or outdoor use	<b>Approvals</b>	
<b>Mechanical</b>		ATEX coding	II 1 G
Body material	UPVC (stabilised)	CENELEC / CSA	EEx ia IIC T4 (Ta : -40°C to +60°C) EEx ia IIC T6 (Ta : -40°C to +55°C)
Lock-nut	G1" Nylon		
Bracket	316 Stainless Steel		
Cable	PVC two core shielded cable		
Weight	1.2 Kg		

\* Under stable operating conditions.  
(Accuracy in near range 0.3 to 1.0m is better than +/- 7mm.)

## Ordering information

<b>MSP</b>	Mobrey ultrasonic level transmitter
<b>900</b>	UPVC construction, 12m operating range
<b>SH</b>	Factory sealed transmitter, HART communications
<b>-A</b>	ATEX/CSA certified I.S. (Zone 0)
<b>/3</b>	Fitted with 3m two core shielded cable
<b>/20</b>	Fitted with 20m two core shielded cable
<b>/50</b>	Fitted with 50m two core shielded cable
<b>MSP 900 SH -A /20</b> Typical model number	

## Dimensions

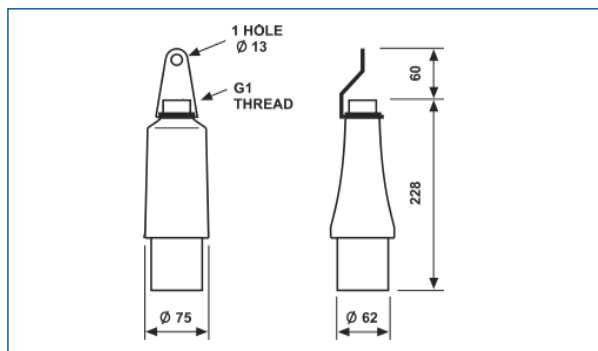

## Accessories and associated equipment

**MSP-SUB2** Optional tubular shield which fits over transmitter housing to prevent fouling of transmit face in the event the transmitter becomes submerged.

**MSP-HVD** Head Verification Device often used on open channel flow applications to allow routine checking and certification of the transmitter. Supports the transmitter and a target plate at a fixed distance from the transmit face which may be swung under the transmitter allowing verification of transmitter accuracy. See data sheet IP267.

**MCU900** Series of control units to power and use with MSP transmitters, providing comprehensive control functionality for pumps and alarms. May also be used with any industrial 4-20mA or HART compatible transmitter. See data sheet IP2031 and IP2033 (logging versions)

**Systems for the water industry** Level and flow control systems designed for the water industry, featuring Mobrey ultrasonic and hydrostatic transmitters together with MCU900 control units. See data sheet IP203.

Useful installation information is given in instruction leaflet IP2040/IM, and application and operating information for Mobrey systems is given in Quick-start booklets IP2040/QS, IP2041/QS & IP2042/QS, available on request.

### Mobrey Measurement

158 Edinburgh Avenue, Slough,  
Berks UK SL1 4UE  
Tel: +44 (0)1753 756600  
Fax: +44 (0)1753 823589  
e-mail: mobrey.sales@  
EmersonProcess.com  
www.mobrey.com

### Mobrey Inc.

19408 Park Row, Suite 320,  
Houston, TX 77084 USA  
Tel: 281 398 7890  
Fax: 281 398 7891  
e-mail: mobrey.sales@  
EmersonProcess.com  
www.mobrey.com

Mobrey GmbH  
Mobrey Ltd  
Mobrey sp z o o  
Mobrey AB  
Mobrey SA  
Mobrey SA-NV

Deutschland tel: 0211/99 808-0  
China tel: 021 3972 0065  
Polska tel: 022 871 7865  
Sverige tel: 08-725 01 00  
France tel: 01 30 17 40 80  
Belgium tel: 02/465 3879



The right is reserved to amend details given in this publication without notice