



Liquid Flow Switch

Model : SF



SeoJin Instech Co., Ltd.

www.seojin.biz



Features

- Small size of this instrument makes it easy to install in the field.
- On/Off action of the switch is very definite, owing to the paddle style flow sensor.
This device has an extremely long life expectancy since the movement of the paddle is transmitted to the switch through a flexible bellows. (Fatigue limit of the bellows is greater than 100,000 times.)
- Unitized construction of this model reduced the parts count, and made it simpler to assemble, thus a more reliable long-term working is expected.
- "Using an ABS case" led to a more attractive design and also made it highly corrosion resistant.

► Adjustment Flow Rate

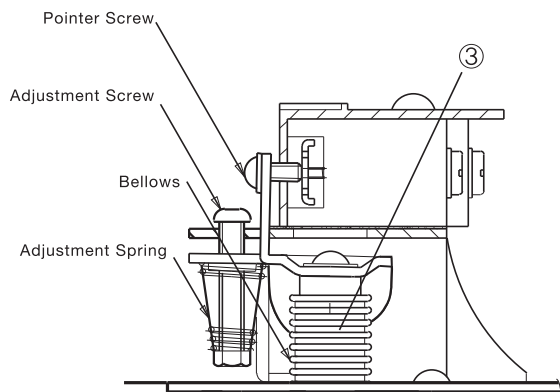

Principle

A reactive force is induced in the paddle in proportion to the rate of flow in the pipe, and the reaction in turn generates a proportional resistance in the control spring. Thus a variable force balance is maintained between the flow and the control spring until the flow exceeds a set flow rate. When the flow reaches the set point, the Reaction Plate activates the micro-switch to make or break the contacts.

► Table of characteristics of flow amount

Classification of contact section		Range of Adjusting Characteristics ℓ /min			
Diameter of pipe(inch)	Paddle No.	Minimum		Maximum	
		ON	OFF	ON	OFF
1	1"	15	8	45	41
1 1/4		26	13	75	68
1 1/2		39	20	120	105
2	2"	34	17	105	94
2 1/2		68	34	210	188
3	3"	60	30	188	175
4		128	64	412	360
5		225	113	750	652
6		345	172	1125	975

This table for measuring flow amount indicates the ranges of control according to the experimental data obtained in case of assembling the paddles in 1", 2" and 3" on each pipe from 1" to 6".

As the values of moving flow amount are changed by $\pm 10\%$ according to the conditions, the flow amount gauge should be used to adjust the Span when precise data of moving flow amount is required. (This table is made under the condition that the depths of the screw is $11.0 \pm 1.0\text{mm}$)

Reference Data

- Below figure is showing relationship between the diameters of pipe and the dimensions of the paddle.
- See the below characteristic graph of pressure loss. This graph shows the pressure loss arising from the paddle.

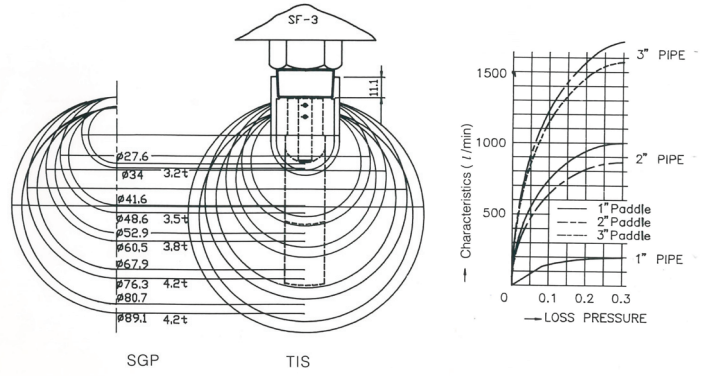

Overall Dimensions

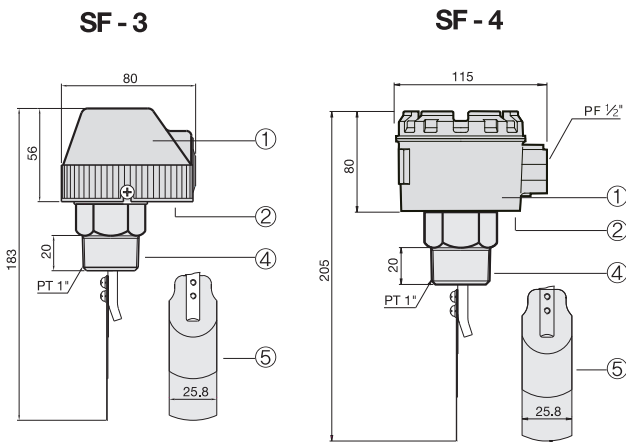

Material

	MODEL	SF - 3	SF - 4
①	Cover	ABS Resin	ADC
②	Bracket	Zn plated C.S	304SS
③	Bellows	Phosphor bronze	Phosphor bronze
④	Socket	Brass	Brass
⑤	Paddle	304SS	304SS

Physical Data

MODEL	SF - 3	SF - 4
Temp. Limits	+ 100°C	+ 100°C
Operating Pressure	10Kgf/cm ²	10Kgf/cm ²
Electrical Rating	120/240V AC 5A	120/240V AC 5A
Weight	Approx. 500g	Approx. 1.5Kg
Construction	IP43	Weather Proof, IP 65
Min. Operating Force	5N	5N

Installation

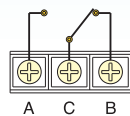

C : Common
B : Normally Close

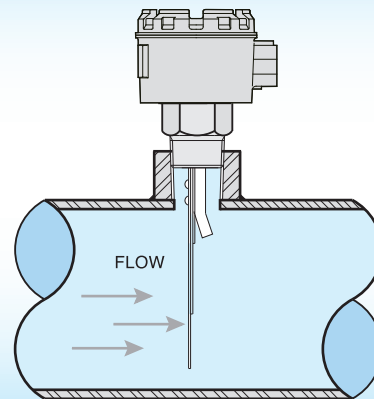

Ordering Information

■ Liquid Flow Switch

SF -	3	A	1	A
------	---	---	---	---

TYPE OF PADDLE

A = 3/4", 1" (in case PT 3/4" Std.)
 B = 1", 2", 3" (in case PT 1" Std.)
 C = 1", 2", 3", 4", 5", 6" (in case PT 1" Only)

MOUNTING SIZE

1 = PT 3/4" (Std.)
 2 = PT 1" (Std.)
 OP = etc.

WET PART MATERIAL (Tee or welding socket thread)

A = MBSBE2 & 304SS (Std.)
 B = 304SS

ENCLOSURE(Housing)

3 = Standard type (ABS Resin)
 4 = Weather proof (ADC)

■ When placing an order, selected ordering number should be indicated on the purchase order sheet.

For custom paddle models, please supply the following information :

Pipe size, flow direction, mounting, pressure, temperature, specific gravity and flow rates.



14, Dunchon-daero 457beon-gil, Junwon-gu
 Seongnam-si, Gyeonggi-do, Korea[Zip.13218]

☎ +82-31-627-9000 🏠 +82-31-624-5345

<http://www.seojin.biz>

2018 Edition Rev.0 (printed by Daoom)

■ Specifications subject to change without notice