

KRACHT

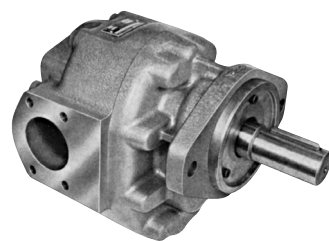

High Pressure Gear Pumps

KP 5

Construction

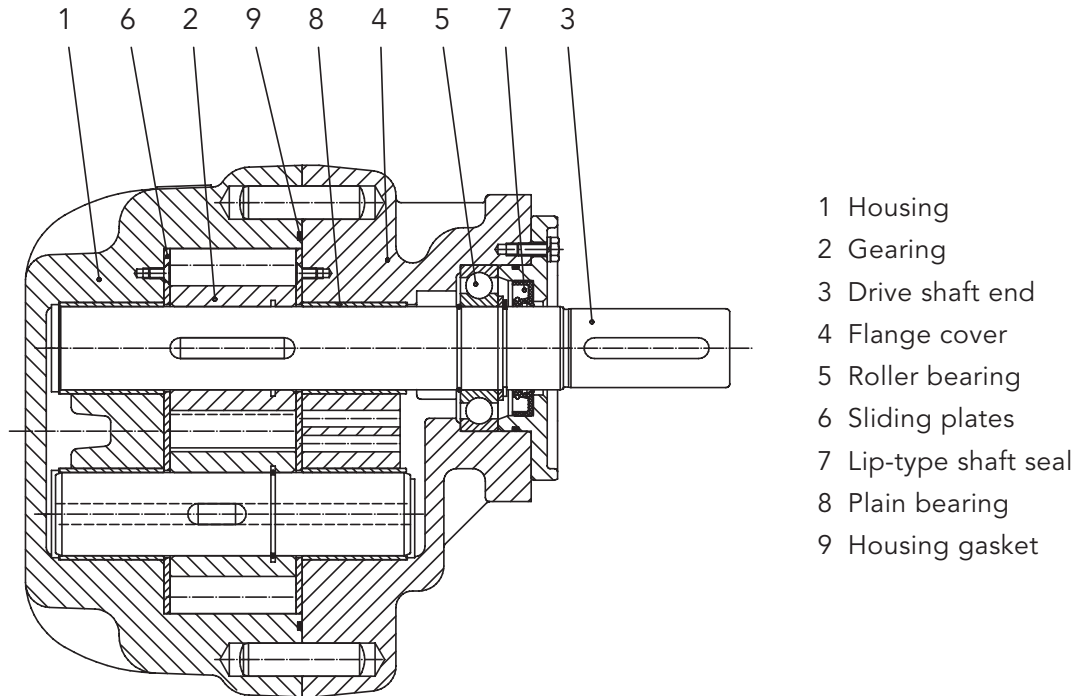

Description

KP series high pressure gear pumps are mainly used in oil-hydraulic plants. They are suitable both for hydraulic fluids as well as mineral oil bases (DIN 51524/25) and engine oils (DIN 51511).

The housing components are made from high-grade cast iron, the shaft and gears from hardened and ground case-hardening steel.

The shafts are supported in multi-layer bearings that have excellent antifriction properties. The seals in the drive shaft ends are made using solely NBR or FKM shaft seals.

An outboard bearing is placed on the shaft end to handle radial and axial forces.

The use of fine-meshed filters significantly increases the gear pump service life. Careful maintenance is the prerequisite.

Technical Information

1. External loads

The robust design facilitates handling external radial forces, depending on the size and direction of application.

2. Direction of rotation

The following stipulations apply to the direction of rotation when looking at the drive shaft end:

Shaft rotation clockwise: direction of conveyance from left to right

Shaft rotation counter clockwise: direction of conveyance from right to left

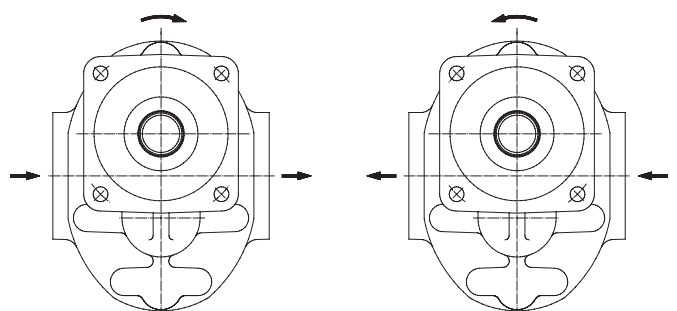

General Characteristics

Fixing type	Flange type
Pipe connection	Flange; Dimensions, page 8
Drive shafts	Dimensions, page 8
Direction of rotation	clockwise or anticlockwise
Weight	Page 7
Mounting position	optional
Ambient temperature	$\vartheta_{u \min} = -20\text{ °C}$ $\vartheta_{u \max} = +60\text{ °C}$

Operating Characteristics

Operating pressure	
Inlet port	$p_{e \min} = -0.4\text{ bar}$ (underpressure) $p_{e \max} = 2.0\text{ bar}$
Outlet port	$p_{\max} =$ Table, page 5
Fluid temperature	$\vartheta_{m \min} = -20\text{ °C}$ $\vartheta_{m \max} = +80\text{ °C}$ for NBR-Lip-type shaft seal + 120 °C for FKM-Lip-type shaft seal
Viscosity	$v_{\min} = 13\text{ mm}^2/\text{s}$ (cSt) $v_{\max} = 600\text{ mm}^2/\text{s}$ (cSt)
Recommended viscosity range	$v = 16 \dots 90\text{ mm}^2/\text{s}$ (cSt)
Discharge flow	Page 5
Input power	Page 5
Filter fineness	Return line filter $\leq 0.060\text{ mm}$ mesh size
Hydraulic fluids	Mineral oil based on DIN 51524/25 Motor oil based on DIN 51511 flameproof hydraulic fluids on request

ATEX

Products and media on request

Accessories

Straight flange connection, hole pattern based on SAE standard. Differential coupling for cyl. shaft end. Intermediate flange to standard motors with fastening flange according to DIN 42948.

Calculation Formulas for Hydropumps

Characteristics, formula signs, units

1 Discharge/displacement flow	Q	l/min
2 geom. discharge/displ. flow	V_g	cm^3/r
3 Pressure	p	bar
4 Speed	n	1/min
5 Torque	M	Nm
6 Power	P	kW
7 Total efficiency	η_{tot}	-
8 Volumetric efficiency	η_{vol}	-
9 hydr./mech. efficiency	η_{hm}	-
10 Flow velocity	v	m/s
11 Piping diameter	d	mm

General:

$$Q_{\text{th}} = V_g \cdot n, \quad \eta_{\text{tot}} = \eta_{\text{vol}} \cdot \eta_{\text{hm}}$$

$$M = 9549 \cdot \frac{P}{n} \quad p = \frac{M \cdot n}{9549} \quad v = 21,22 \cdot \frac{Q}{d^2}$$

Recommended values for KRACHT products at the nominal operating pressure

	η_{tot}	η_{vol}
KP 5	≈ 0.85	≈ 0.95

Parameters for:	Volume flow	Discharge flow $Q = \frac{V_g \cdot n \cdot \eta_{\text{vol}}}{10^3} \left[\frac{\text{l}}{\text{min}} \right]$
	Torque	Drive torque $M = \frac{p \cdot V_g}{20 \cdot \pi \cdot \eta_{\text{hm}}} \text{ [Nm]}$
	Performance	Input power $P = \frac{p \cdot Q}{600 \cdot \eta_{\text{tot}}} \text{ [kW]}$

Displacement / Nominal Size

Displacement Nominal size	geom. displacement V_g cm^3/r	max. operating pressure p_b bar	Speed range 1/min		Torque M_{max} Nm	Permitted torques in N middle at shaft ends ($n = 1450$ 1/min)		Mass inertia torque $\times 10^{-3}$ J kg/m^2
			n_{min}	n_{max}		axial	radial	
160	160	100	800	2000	560	400	1500	3.77
200	200	100	800	1800				4.57
250	250	100	800	1600				5.87
300	300	80	800	1500				6.50

Discharge Flow and Required Input Power

Discharge flow at n = 950 1/min

Nominal size	Discharge flow Q in 1/min at 34 mm ² /s Pressure p in bar					
	10	20	40	60	80	100
160	150	149	147	146	144	143
200	190	189	187	185	183	181
250	239	238	236	234	232	230
300	286	285	284	283	281	–

Required input power P in kW at n = 950 1/min

Nominal size	Pressure p in bar					
	10	20	40	60	80	100
160	3.5	6.5	12	17.5	23	29
200	4	8	14.5	22	29	36
250	5	9.5	18	26.5	35	43.5
300	6	11.5	21.5	32	42.5	–

Discharge flow at n = 1450 1/min

Nominal size	Discharge flow Q in 1/min at 34 mm ² /s Pressure p in bar					
	10	20	40	60	80	100
160	227	225	223	221	219	216
200	285	284	282	280	278	276
250	358	356	354	352	349	346
300	429	428	426	424	422	–

Required input power P in kW at n = 1450 1/min

Nominal size	Pressure p in bar					
	10	20	40	60	80	100
160	5.5	10	18.5	27	36	44.5
200	6.5	12	23	33.5	43.5	54
250	8.0	14	27.5	41	54	67
300	9.5	17.5	33	49	64.5	–

Tolerance zone of the discharge flow: – 5 % of table value Q.

Select the delivery power of each drive motor approx. 20 % greater than table value P.

If the viscosity is less than 30 mm²/s (cSt), reduce discharge flow Q

If the viscosity is more than 75 mm²/s (cSt), consider the addition to the input power, if over 300 mm²/s (cSt), reduction of the speed.

Dimensions

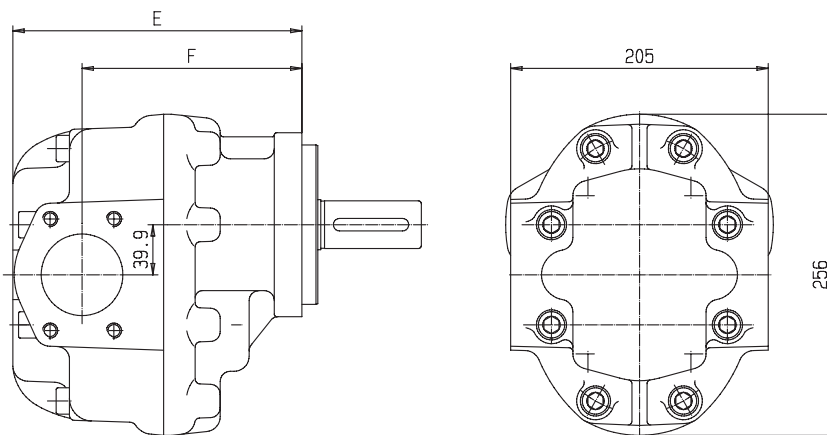

Displacement Nominal size	E	F	Weight in kg	
			Version C flange	Version E flange
160	225	170	42	43
200	230	175	44	45
250	243	188	48	49
300	255	200	52	53

Flange Type

SAE-C-2 hole flange C,
LA = 181; $\varnothing z = 127$

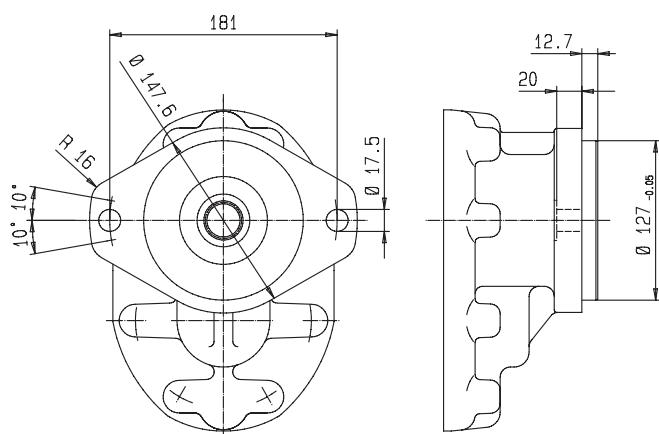

SAE-C-4 hole flange E,
LA = 114.55; $\varnothing z = 127$

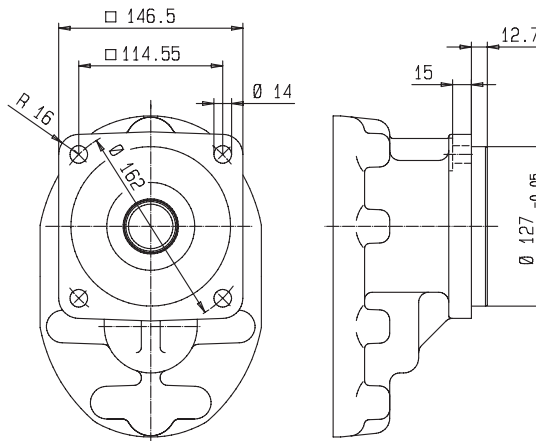

Connections

Housing side ports
Inlet port 2 1/2" SAE connection (Ø 65)

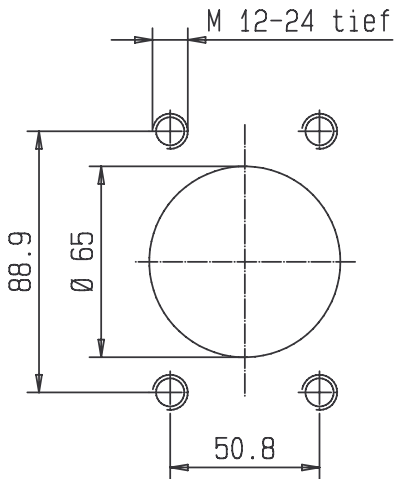

Housing side ports
Outlet port 2" SAE connection (Ø 50)

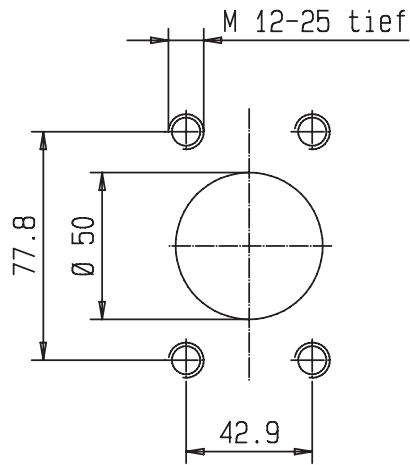

Shaft Ends

Shaft end T
Spline profile SAE-C
Z = 14; DP 12/24, $\alpha = 30^\circ$

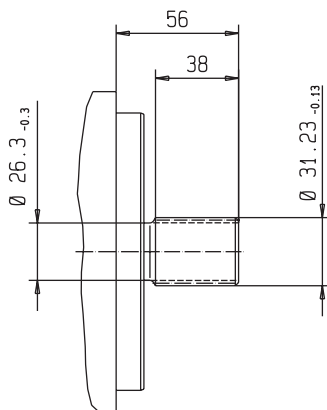

Shaft end V
Spline profile W 40 x 2, DIN 5480

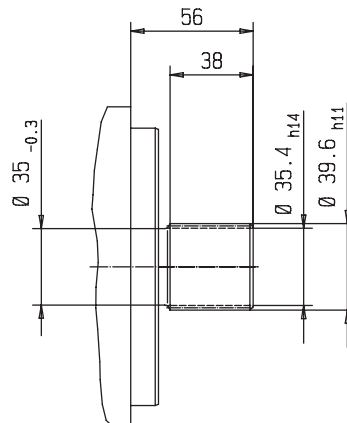

Shaft end Z
Cylindrical shaft Ø 38

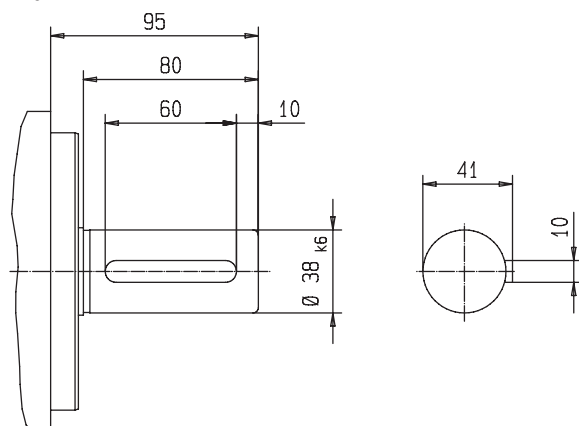

Accessory, Couplings

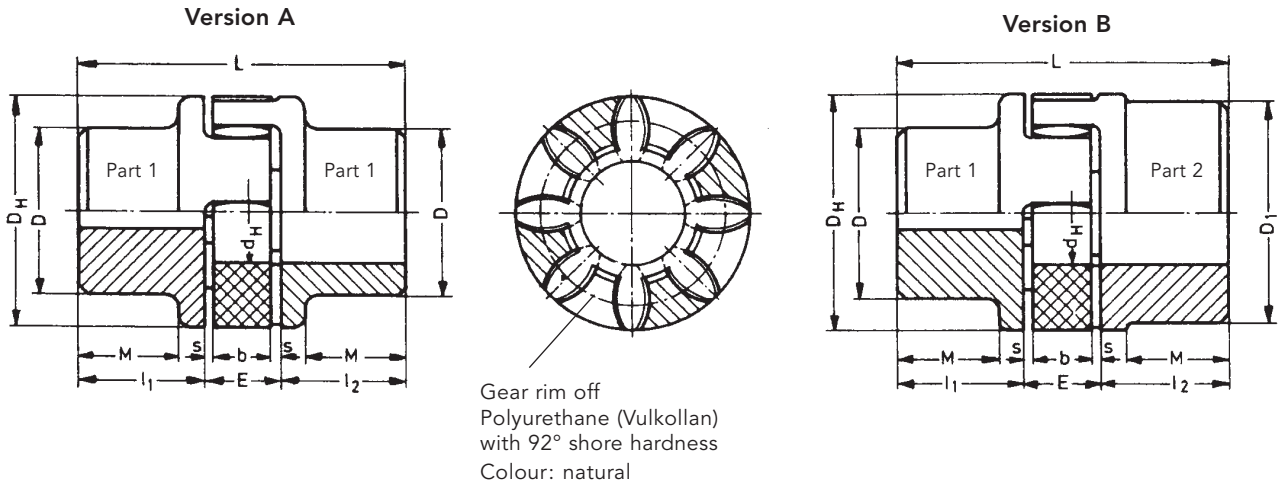

Ordering code

**RA
RG 38**

-

Z 45/38

-

Z 45/38

Hub material	
A	AL
G	GG

Coupling size
in Al (aluminium)
in GG (cast iron)

Coupling hub length
and hub bore
Pump side cylindrical

Coupling hub length
and hub bore
Motor side zylindrical

	Coup- ling size	Hub material				Lead bore		Finished bore				Dimensions										Ordering code	
		Al		GG		Part 1	Part 2	min.		max.		l ₁ ; l ₂	E	s	b	L	M	D _H	D	D ₁	d _H		
		Weight Kg	Mass moment of inertia Kgm ²	Weight Kg	Mass moment of inertia Kgm ²			Part 1	Part 2	Part 1	Part 2												Part 1
Version A	38	0.82	0.0007	2.08	0.002	10	-	12	-	38	-	45	24	3	18	114	37	80	66	66	-	38	R.38-Z45/..-Z45/..
	42	1.25	0.0014	3.21	0.004	12	-	14	-	42	-	50	26	3	20	126	40	95	75	75	-	46	R.42-Z50/..-Z50/..
	48	1.71	0.0024	4.41	0.006	13	-	15	-	48	-	56	28	3,5	21	140	45	105	85	85	-	51	R.48-Z56/..-Z56/..
Version B	38/45	0.89	0,0008	2.27	0.002	10	36	12	38	38	45	45	24	3	18	114	37	80	66	66	76	38	R.38/45-Z45/..-Z45/..
	42/55	1.39	0.0018	3.57	0.005	12	40	14	42	42	55	50	26	3	20	126	40	95	75	75	94	46	R.42/55-Z50/..-Z50/..
	48/60	1.86	0.0030	4.8	0.008	13	46	15	48	48	60	56	28	3.5	21	140	45	105	85	85	102	51	R.48/60-Z56/..-Z56/..
	55/70	-	-	7.37	0.016	18	52	20	55	55	70	65	30	4	22	160	52	120	-	98	120	60	R.55/70-Z65/..-Z65/..
	65/75	-	-	10.9	0.031	20	63	22	65	65	75	75	35	4.5	26	185	61	135	-	115	135	68	R.65/70-Z75/..-Z75/..
	75/90	-	-	17.7	0.068	28	73	30	75	75	90	85	40	5	30	210	69	160	-	135	160	80	R.75/90-Z85/..-Z85/..

Medium temperature: - 10 °C up to + 80 °C (intermittent temperature peaks up to + 120 °C are permissible)

Weights and mass inertial torque are related to max. finished bore without groove

Finished bore based on ISO alignment H7; Keyway according to DIN 6885 Sheet 1

Motor with Pump KP 5 / . C.O. Z00 0DE.

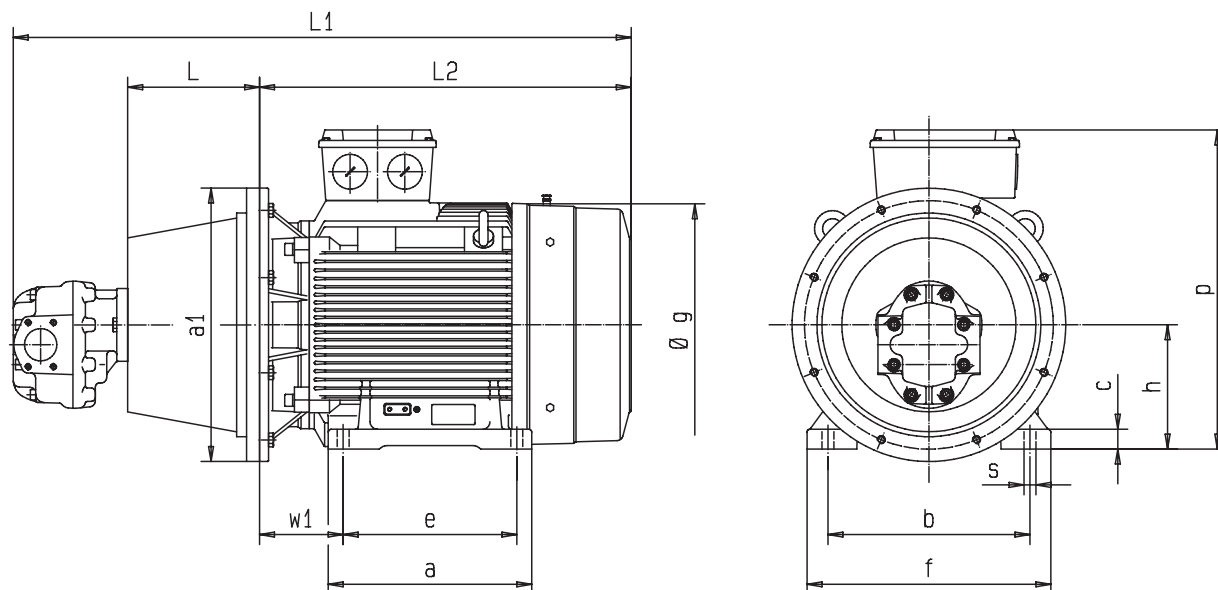

Size	Motor 4-pole		Motor 6-pole		Bell housing	Coupling
	Power kW	Speed 1/min	Power kW	Speed 1/min		
160 M	11	1465	7.5	960	PK 350/10/19	RA 38/45 – Z45/38 – Z45/42
160 L	15	1465	11	960		
180 M	18.5	1470	–	–	PK 350/10/19	RA 42/55 – Z50/38 – Z50/48
180 L	22	1470	15	970		
200 LK	30	1470	18.5/22	975/975	PK 400/5/7	RA 42/55 – Z50/38 – Z50/55
225 S	37	1480	–	–	PK 450/3/23	RA 48/60 – Z56/38 – Z56/60
225 M	45	1480	30	980		
250 M	55	1480	37	980	PL 550/1/9	RG 55/70 – Z65/38 – Z65/65
280 S	75	1485	45	985	PK 550/3/9	RG 65/75 – Z75/38 – Z75/75

All motor dimensions and information refer to the ADDA motor make, other motor makes on request. Motor mounting IMB35

Size	160	200	250	300	160-300												
	L ₁	L ₁	L ₁	L ₁	L	a ₁	a	b	c	e	f	Øg	h	L ₂	p	s	w ₁
160 MT	913	918	931	943	228	350	250	254	18	210	292	290	160	460	375	14	108
160 L	993	998	1011	1023	228	350	332	254	20	254	315	325	160	540	405	14	108
180 M	1033	1038	1051	1063	228	350	320	279	22	241	350	340	180	580	425	14	121
180 L	1033	1038	1051	1063	228	350	320	279	22	279	350	340	180	580	425	14	121
200 L	1093	1098	1111	1123	228	400	365	318	24	305	395	380	200	640	475	18	133
225 S	1177	1182	1195	1221	262	450	370	356	30	286	436	420	225	690	515	18	149
225 M	1177	1182	1195	1221	262	450	370	356	30	311	436	420	225	690	515	18	149
250 M	1255	1260	1273	1285	265	550	410	406	32	349	476	480	250	765	580	22	168
280 S	1390	1395	1408	1420	275	550	480	457	35	368	534	535	280	890	680	22	190

All pump and motor sizes can be combined with each other

Product Portfolio

Transfer Pumps

Transfer pumps for lubricating oil supply equipment, low pressure filling and feed systems, dosing and mixing systems.

Mobile Hydraulics

Single and multistage high pressure gear pumps, hydraulic motors and valves for construction machinery, vehicle-mounted machines.

Flow Measurement

Gear and turbine flow meters and electronics for volume and flow metering technology in hydraulics, processing and laquering technology.

Industrial Hydraulics / Test Bench Construction

Cetop directional control and proportional valves, hydraulic cylinders, pressure, quantity and stop valves for pipe and slab construction, hydraulic accessories for industrial hydraulics (mobile and stationary use).

Technology Test benches / Fluid Test benches.



KP5/GB/02.08

KRACHT