

# KRACHT

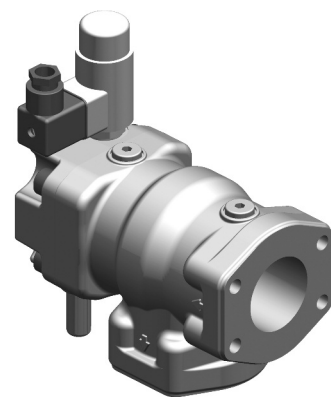

Pressure Valves

**DV**

hydraulically pilot-operated

## Description

The DV pressure valves are hydraulically pilot-controlled valves. They comprise a main valve and one or several pilot-controlled valves. The modular design permits using different pilot control valves which means a multitude of functions can be implemented.

Along with pressure limiting and pressure control functions, this also includes special solutions such as pressure range switching valves and valves with electric relief. Typical application areas are oil hydraulics and lubrication technology.

## Product Characteristics

- Pilot-controlled pressure valves for large volume flows of up to 1800 l/min
- Wide functionality through modular construction
- Supplied standard with outlet port measurement connector M
- External control-oil regulation connector X (e.g. for hydraulic relief)
- Redundant pressure protection with maximum pressure limitation (optional)
- Dimensionally interchangeable with KRACHT type SPV(F) and HV(F) valves
- Marine acceptance by various classification companies on request

## Construction

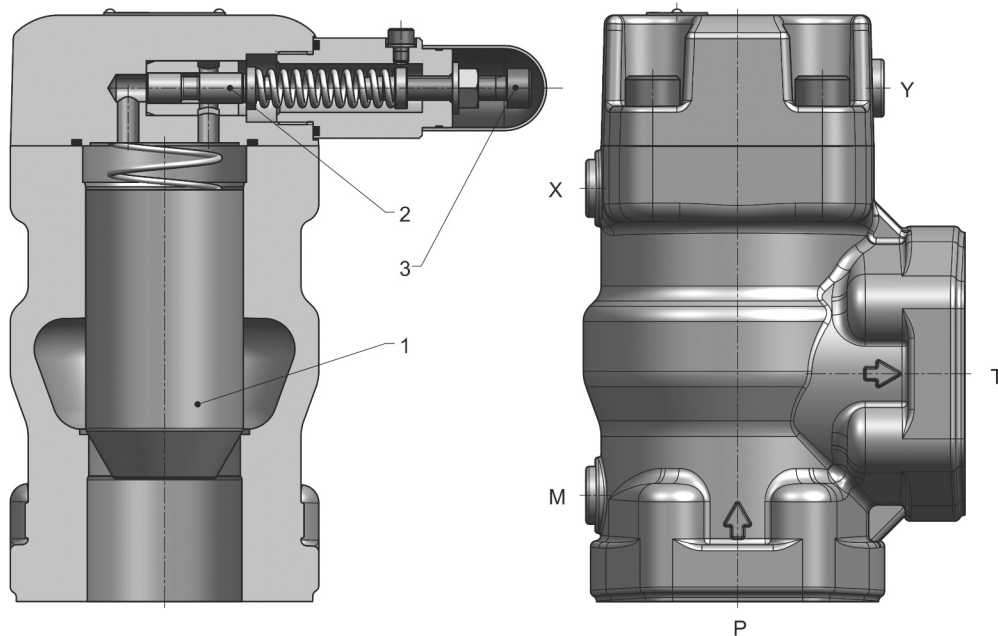

## Function Pressure Relief Valve DV B

With the valve closed, both Main pilot valve cone **1** as well as Main pilot valve cone **2** are kept in the closed position by the spring force of the return spring.

As soon as the pressure exceeds the pressure set with Setscrew **3**, the pilot valve opens and the spring chamber of the main valve is relieved to Tank **T**.

A pressure gradient arises between Pressure port **P** and the spring chamber and the main valve cone opens, keeping the system pressure constant. The control oil can be discharged **Y** internally or externally.

A measurement connector (**M**) and a port for external control oil regulation (**X**) are provided as standard.

**DV B Pressure Relief Valve**

**Circuit Symbols**

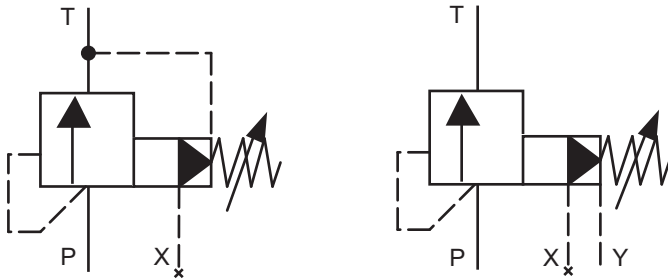

Control oil: internal drainage    Control oil: external drainage (Y)

**Option with directional valve**

The DV B pressure relief valve is also available on request with an additional 2/2-directional valve (e.g. for depressurized circulation). The directional valve here is available as an open de-energised or closed de-energised version.

**Circuit symbol**

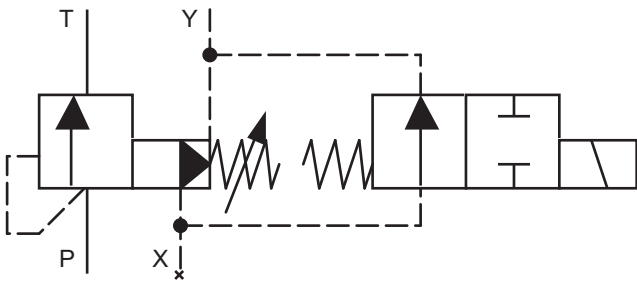

DV S Pressure Stage Control Valve

The pressure stage control valve is a pilot-controlled pressure relief valve with two parallel switched pilot-control valves which can be set to different pressures. The basic setup corresponds to the DV B pressure relief valve. The pressure stage control valve has an integrated 2/2 directional valve in addition.

It is used to switch the low pressure stage (upstream pressure) on and off. The magnetic valve here is available as an open de-energised or closed de-energised design. The control oil drainage here can also be implemented internally or externally. A typical application field is the coupling control of ship transmissions.

Circuit symbols

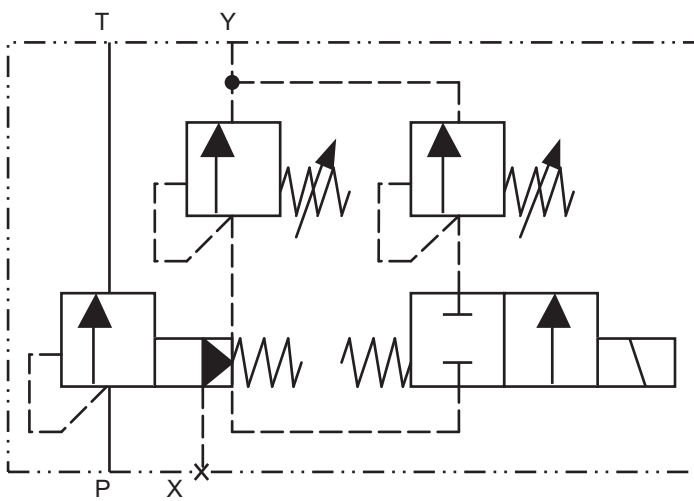

Control oil: external drainage (Y), magnetic valve closed de-energised

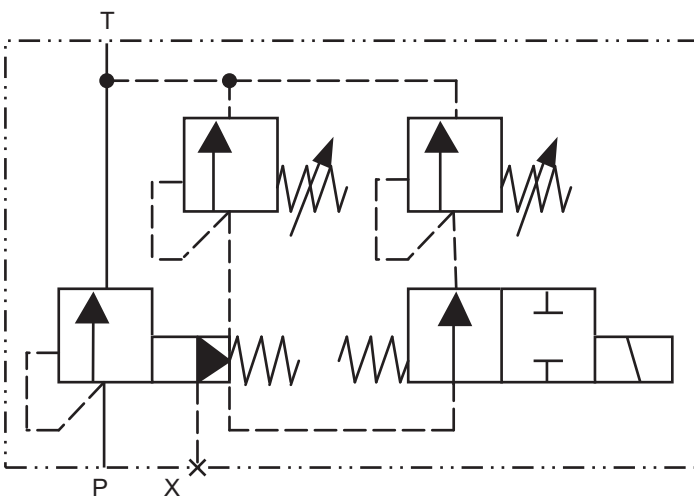

Control oil: internal drainage (Y), magnetic valve open de-energised

**DV R Pressure Control Valve**

The pressure control valve is a pilot-controlled pressure relief valve with external hydraulic triggering. It facilitates controlling a system pressure independent of the pressure losses between the valve and the point of the external control-oil tap. To accomplish that the pressure preset on the adjusting spindle on the connection (Z) is kept constant.

In addition, the valve is furnished with a permanently set maximum pressure relief (set-to-operate pressure = 9 bar).

A typical application field is the pressure control of lubrication oil circuits in diesel engines.

**Circuit symbol (simplified)**

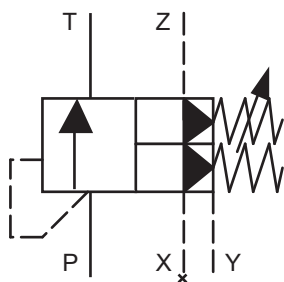

**Circuit symbol (comprehensive)**

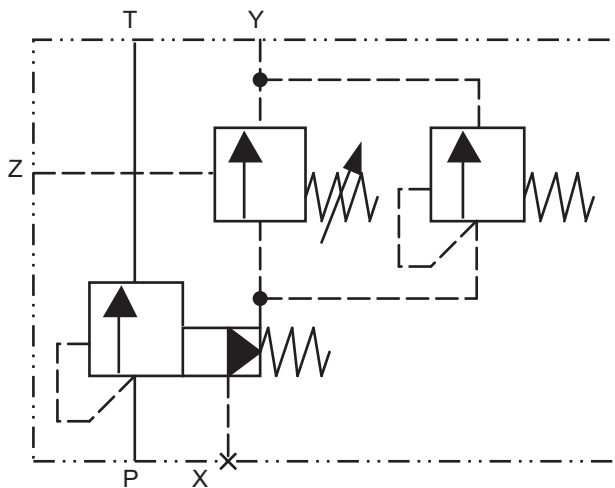

General note:

Hydraulic counter-pressures in Connection T with internal control-oil return or in Connection Y with external control-oil return add up 1:1 to the response pressure of the valve set on the pilot control.

**Technical Datas**

**General Characteristics**

Design	Seat valve, hydraulically pilot controlled
Fixation type	Pipeline
Line connection	SAE flange (SAE J518, code 61)
Mounting position	optional
Type of operation	Mechanical, setscrew
Housing material	EN-GJS-400-15
Seal material	FKM (others on request)
Pressure fluids	<ul style="list-style-type: none"> <li>- Hydraulic fluids as per DIN 51524/25</li> <li>- Marine fuels as per DIN ISO 8217</li> <li>- Motor and gearing oils</li> <li>- bio-oils of type "HEES"</li> <li>(Others on request)</li> </ul>

**Hydraulic characteristics**

Nominal size		50	80
max. flow rate		800 l/min	1800 l/min
Nominal pressure		210 bar	140 bar
Viscosity (Others on request)	$v_{min}$	4 mm <sup>2</sup> /s	4 mm <sup>2</sup> /s
	$v_{max}$	1000 mm <sup>2</sup> /s	1000 mm <sup>2</sup> /s
Media temperature (FKM)	∅	-15...150 °C	-15...150 °C
Ambient temperature	∅	-20...60 °C	-20...60 °C

**Set Pressure Range**

Function	Pressure stage	Pressure [bar]
DV B	1	3...25
	2	8...70
	3	15...140
DV R	1	3...25
	2	8...70 (without maximum pressure relief)
	3	15...140 (without maximum pressure relief)
DV S	1	3...10 / 10...35

Type Key

Ordering example

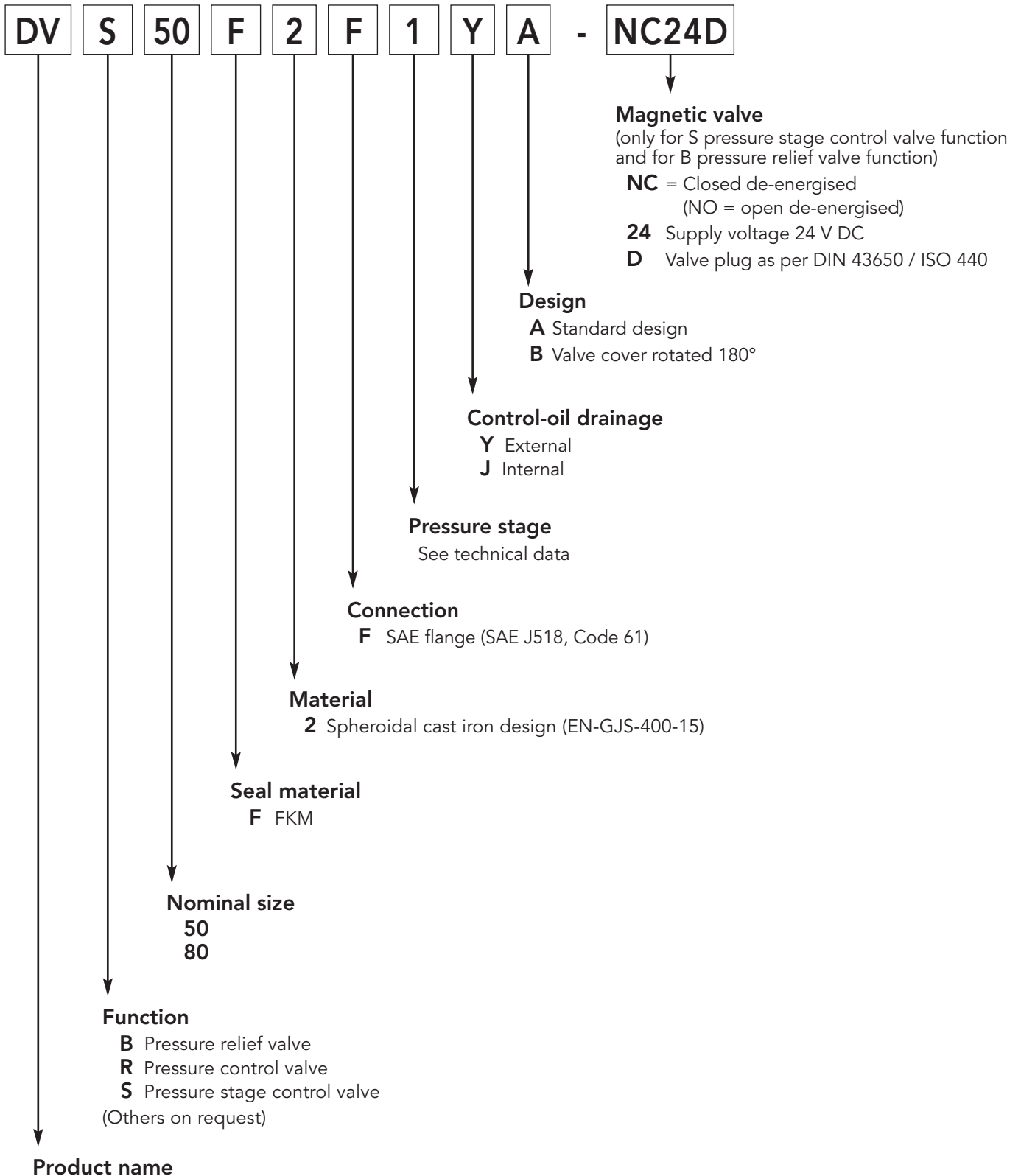

**p-Q Characteristic Curves** (Viscosity = 34 mm<sup>2</sup>/s)

Nominal size 50 and 80

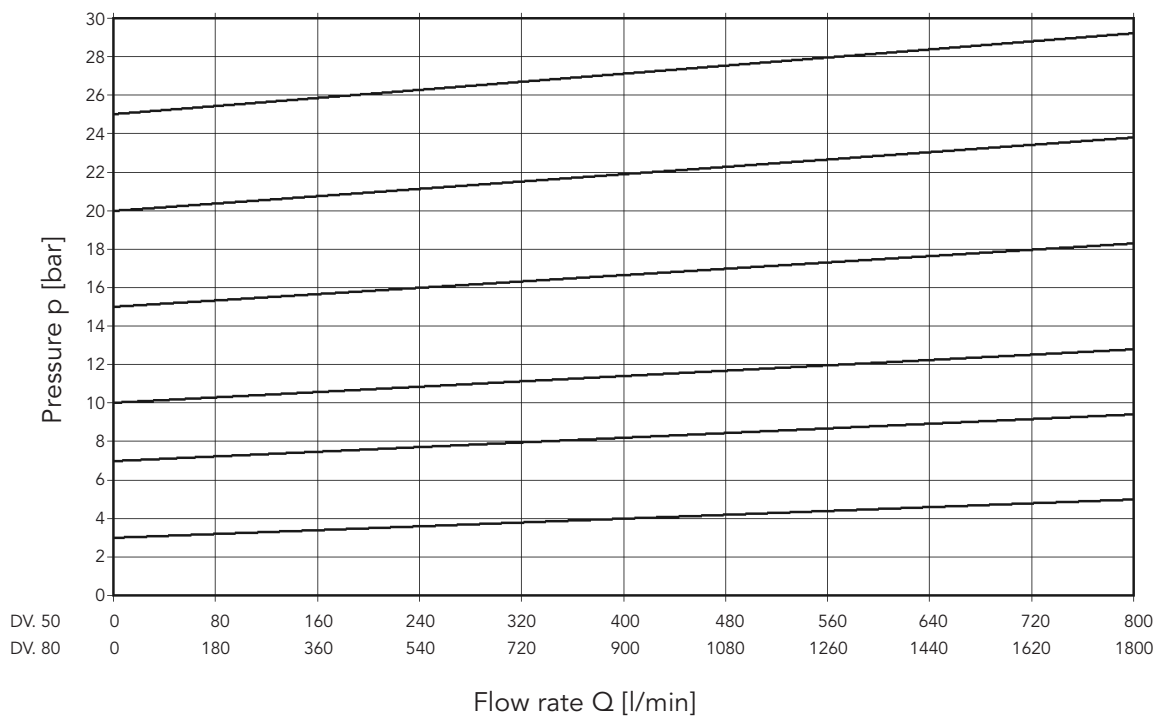

Nominal size 50 and 80

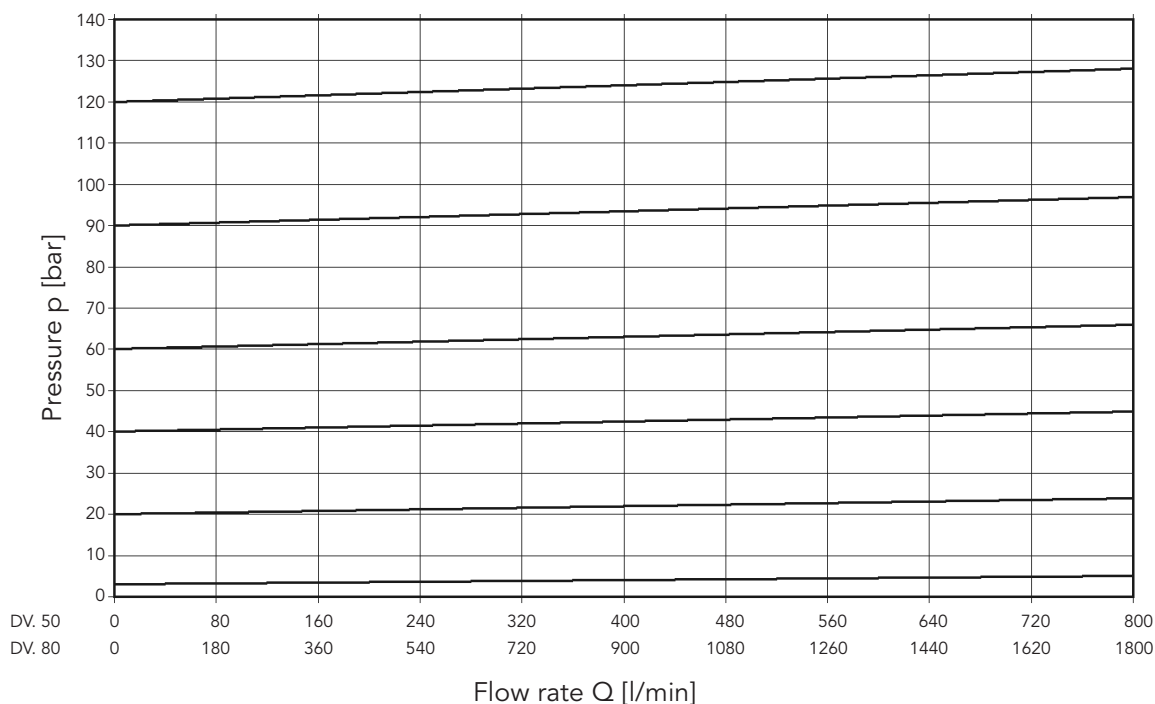



**Dimensions DV . B Pressure Relief Valve (in mm)**

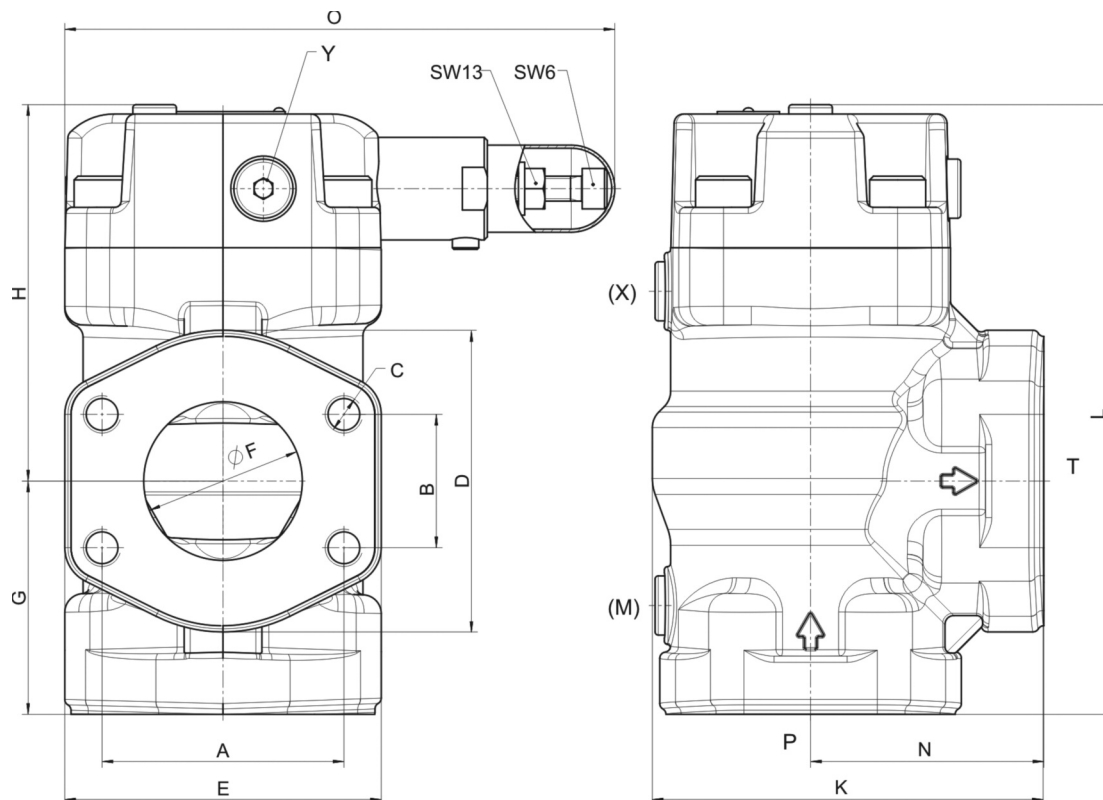

Nominal size	SAE	A	B	C	D	E	F	G	H	K	L	N	O	Weight in kg
50	2"	77.8	42.9	M12	97	102	51	75	121	126	196	75	177	9.7
80	3"	106.4	61.9	M16	131	135	76	110	151	177	261	110	209	21.2

Connections (M), (X), Y: G $\frac{1}{4}$   
 Connections P and T are dimensionally identical

Dimensions DV . R Pressure Control Valve (in mm)

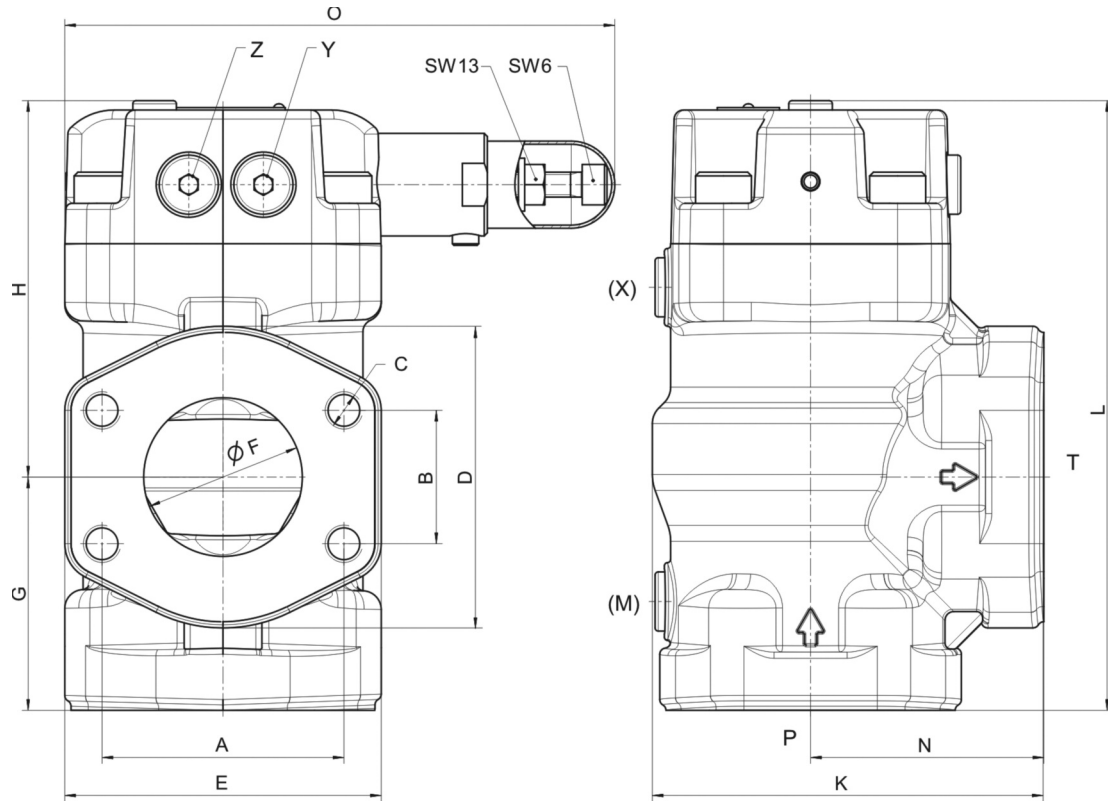

Nominal size	SAE	A	B	C	D	E	F	G	H	K	L	N	O	Weight in kg
50	2"	77.8	42.9	M12	97	102	51	75	121	126	196	75	177	9.7
80	3"	106.4	61.9	M16	131	135	76	110	151	177	261	110	209	21.2

Connections (M), (X), Y: G $\frac{1}{4}$   
 Connections P and T are dimensionally identical

**Dimensions DV . S Pressure Stage Control Valve (in mm)**

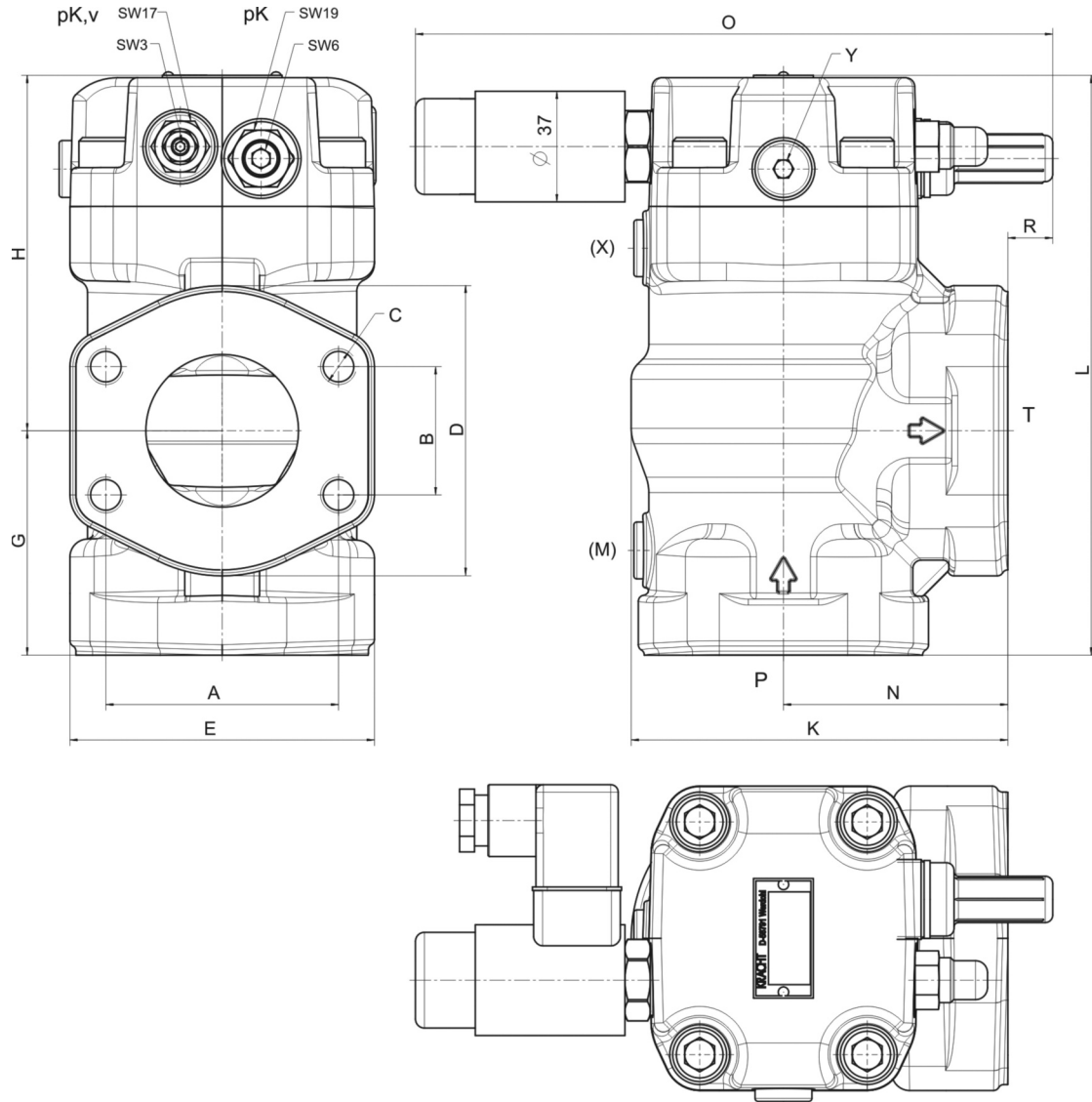

Nominal size	SAE	A	B	C	D	E	F	G	H	K	L	N	O	R	Weight in kg
50	2"	77.8	42,9	M12	97	102	51	75	119	126	194	75	213	15	9.8
80	3"	106.4	61.9	M16	131	135	76	110	149	177	259	110	240	-13*	21.4

Connections (M), (X), Y: G $\frac{1}{4}$

Connections P and T are dimensionally identical

\* Dimension R: stands back 13 mm behind the edge of the object

pK = Coupling compression (high pressure setting)  
 pK,v = Coupling supply pressure (low pressure setting)

# Product Portfolio

## Gear Pumps

Gear pumps for lubricating oil supply equipment, low pressure filling and feed systems, dosing and mixing systems.

## Mobile Hydraulics

Single and multistage high pressure gear pumps, hydraulic motors and valves for construction machinery, vehicle-mounted machines.

## Flow Measurement

Gear, turbine and screw type flow meters and electronics for volume and flow metering technology in hydraulics, processing and laquering technology.

## Industrial Hydraulics / Test Bench Construction

Cetop directional control and proportional valves, hydraulic cylinders, pressure, quantity and stop valves for pipe and slab construction, hydraulic accessories for industrial hydraulics (mobile and stationary use).

Technology Test benches / Fluid Test benches.



*Pressure Valves DV/GB/10.15*

# KRACHT