

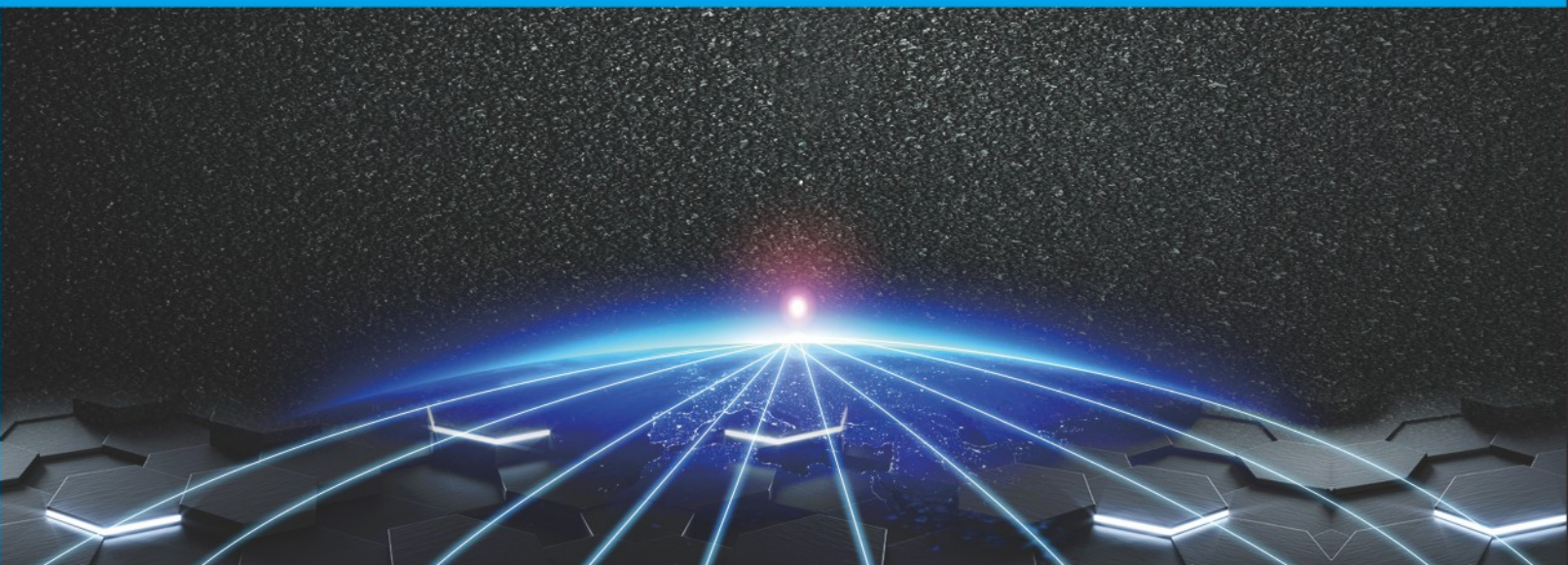

四川德米勒电气有限公司



产品目录 <<



公司简介

Company Profile

四川德米勒电气有限公司，是一家专业从事高中档防水配电箱、防水接线盒、工业插座箱、电气控制箱、端子分线箱、照明配电箱、多媒体智能和光纤入户信息箱等电气设备的专业研发、定制、生产、销售厂家。

我们始终坚持“专业、专一、专注”的产品方向。公司成立至今，在不断优化新产品结构的同时坚持做好售后服务工作，在整合市场资源的同时引入先进企业的管理模式，进一步提高业务及生产部门员工的各项水平。

本公司产品齐全、质量稳定，有着一支年轻而专业的销售队伍，全面采用严格的质量管理制度，充分发挥专业化技术优势，竭诚为各方用户提供优质优量的服务。

不断创新是我们永恒的主题、高效率、高质量、高服务是我们永远的追求。我们秉着忠诚、团结、互惠的原则愿与国内外客户携手并进、共展宏图!



公司理念

Company Philosophy

企业精神：团结、奉献、开拓、创新

经营理念：服务第一、用户第一、质量第一、信誉第一

经营宗旨：公平、公正、公开、高效、诚实守信、科学择优

核心价值观：责任、正直、公平、透明



目录

Contents

塑料防水箱	01-04
铸铝机箱	05
铸铝盒的应用	06
接线端子盒	07-10
悬臂控制箱	11
成套防水配电箱	12
落地式机柜	13
挂墙式机箱	14
LED机柜灯	15
按钮指示灯	16-20
金属按钮	21
电气辅材	22-31
机柜机箱配电线槽	32-33
通用型接线端子	34
项目产品	35
认证证书	36

TJ系列塑料盒（螺栓型）

TJ Series Plastic Enclosure (Screw type)



CE IP66



四川德米勒电气有限公司

塑料防水箱

产品特点

- 1、箱体采用注塑成型方式，与箱体连接具有足够的强度，紧固后不会破裂；
- 2、设计四面滑动模式能有效的抗击冲击，达到IK07/08；
- 3、采用泡沫橡胶点胶成型，防护等级IP66；
- 4、材料分为ABS和PC两种；
- 5、温度范围：-40°C ~ +80°C。

型号规格 Product Model (Stainless steel latch+Screwtype)			内板型号 Plate Model		金属内板规格 Plate Size	
宽x长x深 WHD	灰色盖ABS/PC	PC	塑料 Plastic	金属 Metal	M1	M2
	灰色盖ABS:☐ 透明盖PC:☐ 灰色箱体ABS Body: Grey ABS	灰色盖PC:☐ 透明盖PC:☐ 灰色箱体PC Body: Grey PC				
★ 50×65×55	TJ-A☐-0506	TJ-P☐-0506	-----	TJ-0506	40	55
65×95×55	TJ-A☐-0609	TJ-P☐-0609	-----	-----	--	--
75×125×75	TJ-A☐-0712	TJ-P☐-0712	TJ-0712P	TJ-0712	60	110
75×125×100	TJ-A☐-0712-1	TJ-P☐-0712-1	TJ-0712P	TJ-0712	60	110
80×80×60	TJ-A☐-0808	TJ-P☐-0808	TJ-0808P	TJ-0808	65	65
80×80×85	TJ-A☐-0808-1	TJ-P☐-0808-1	TJ-0808P	TJ-0808	65	65
80×110×45	TJ-A☐-0811-S	TJ-P☐-0811-S	TJ-0811P	TJ-0811	67	91
80×110×60	TJ-A☐-0811-1S	TJ-P☐-0811-1S	TJ-0811P	TJ-0811	67	91
80×110×70	TJ-A☐-0811	TJ-P☐-0811	TJ-0811P	TJ-0811	67	91
80×110×85	TJ-A☐-0811-1	TJ-P☐-0811-1	TJ-0811P	TJ-0811	67	91
80×130×70	TJ-A☐-0813	TJ-P☐-0813	TJ-0813P	TJ-0813	67	117
80×130×85	TJ-A☐-0813-1	TJ-P☐-0813-1	TJ-0813P	TJ-0813	67	117
★ 80×160×55	TJ-A☐-0816-S	TJ-P☐-0816-S	TJ-0816P	TJ-0816	67	151
★ 80×160×90	TJ-A☐-0816	TJ-P☐-0816	TJ-0816P	TJ-0816	67	151

型号规格 Product Model (Stainless steel latch+Screwtype)			内板型号 Plate Model		金属内板规格 Plate Size	
宽x长x深 WHD	灰色盖ABS/PC	PC	塑料 Plastic	金属 Metal	M1	M2
	灰色盖ABS:☐ 透明盖PC:☐ 灰色箱体ABS Body: Grey ABS	灰色盖PC:☐ 透明盖PC:☐ 灰色箱体PC Body: Grey PC				
80×180×70	TJ-A☐-0818	TJ-P☐-0818	TJ-0818P	TJ-0818	70	170
80×180×85	TJ-A☐-0818-1	TJ-P☐-0818-1	TJ-0818P	TJ-0818	70	170
80×220×70	TJ-A☐-0822	TJ-P☐-0822	TJ-0822P	TJ-0822	67	209
80×250×70	TJ-A☐-0825	TJ-P☐-0825	TJ-0825P	TJ-0825	67	237
80×250×85	TJ-A☐-0825-1	TJ-P☐-0825-1	TJ-0825P	TJ-0825	67	237
100×100×75	TJ-A☐-1010	TJ-P☐-1010	TJ-1010P	TJ-1010	80	80
100×100×100	TJ-A☐-1010-1	TJ-P☐-1010-1	TJ-1010P	TJ-1010	80	80
110×180×90	TJ-A☐-1018	TJ-P☐-1018	TJ-1018P	TJ-1018	98	108
110×180×105	TJ-A☐-1018-1	TJ-P☐-1018-1	TJ-1018P	TJ-1018	98	168
125×125×75	TJ-A☐-1212-S	TJ-P☐-1212-S	TJ-1012P	TJ-1012	112	112
125×125×100	TJ-A☐-1212	TJ-P☐-1212	TJ-1012P	TJ-1012	112	112
125×175×75	TJ-A☐-1217	TJ-P☐-1217	TJ-1017P	TJ-1017	112	162
125×175×100	TJ-A☐-1217-1	TJ-P☐-1217-1	TJ-1017P	TJ-1017	112	162
120×200×75	TJ-A☐-1220	TJ-P☐-1220	TJ-1020P	TJ-1020	95	175
★ 120×220×85	TJ-A☐-1222	TJ-P☐-1222	TJ-1222P	TJ-1222	95	175
140×170×95	TJ-A☐-1417	TJ-P☐-1417	TJ-1417P	TJ-1417	127	154
140×230×95	TJ-A☐-1423	TJ-P☐-1423	TJ-1423P	TJ-1423	125	215
150×200×75	TJ-A☐-1520-S	TJ-P☐-1520-S	TJ-1520P	TJ-1520	136	185
150×200×100	TJ-A☐-1520	TJ-P☐-1520	TJ-1520P	TJ-1520	136	185
150×200×130	TJ-A☐-1520-1	TJ-P☐-1520-1	TJ-1520P	TJ-1520	136	185
150×200×130	TJ-A☐-1520-2	TJ-P☐-1520-2	TJ-1520P	TJ-1520	136	185
150×200×160	TJ-A☐-1520-3	TJ-P☐-1520-3	TJ-1520P	TJ-1520	136	185
150×250×100	TJ-A☐-1525	TJ-P☐-1525	TJ-1525P	TJ-1525	135	235
150×250×130	TJ-A☐-1525-2	TJ-P☐-1525-2	TJ-1525P	TJ-1525	135	235
150×250×160	TJ-A☐-1525-3	TJ-P☐-1525-3	TJ-1525P	TJ-1525	135	235
175×175×75	TJ-A☐-1717	TJ-P☐-1717	TJ-1717P	TJ-1717	159	159
175×175×100	TJ-A☐-1717-1	TJ-P☐-1717-1	TJ-1717P	TJ-1717	159	159
175×250×75	TJ-A☐-1725	TJ-P☐-1725	TJ-1725P	TJ-1725	160	230
175×250×100	TJ-A☐-1725-1	TJ-P☐-1725-1	TJ-1725P	TJ-1825	155	230
180×250×100	TJ-A☐-1825	TJ-P☐-1825	-----	TJ-1725	155	230
200×200×95	TJ-A☐-2020-S	TJ-P☐-2020-S	TJ-2020P	TJ-2020	185	185
200×200×125	TJ-A☐-2020-1	TJ-P☐-2020-1	TJ-2020P	TJ-2020	185	185
200×200×130	TJ-A☐-2020	TJ-P☐-2020	TJ-2020P	TJ-2020	185	185
200×200×160	TJ-A☐-2020-2	TJ-P☐-2020-2	TJ-2020P	TJ-2020	185	185
200×250×100	TJ-A☐-2025	TJ-P☐-2025	TJ-2025P	TJ-2025	180	228
200×300×105	TJ-A☐-2030	TJ-P☐-2030	TJ-2030P	TJ-2030	180	275
280×190×130	TJ-A☐-2819	TJ-P☐-2819	TJ-2819P	TJ-2819	160	260
280×190×180	TJ-A☐-2819-2	TJ-P☐-2819-2	TJ-2819P	TJ-2819	160	260
280×190×230	TJ-A☐-2819-3	TJ-P☐-2819-3	TJ-2819P	TJ-2819	160	260
280×280×130	TJ-A☐-2828	TJ-P☐-2828	TJ-2828P	TJ-2828	245	245
280×280×180	TJ-A☐-2828-2	TJ-P☐-2828-2	TJ-2828P	TJ-2828	245	245
280×280×230	TJ-A☐-2828-3	TJ-P☐-2828-3	TJ-2828P	TJ-2828	245	245
340×280×130	TJ-A☐-3428	TJ-P☐-3428	TJ-3428P	TJ-3428	245	305
340×280×180	TJ-A☐-3428-1	TJ-P☐-3428-1	TJ-3428P	TJ-3428	245	305
380×190×100	TJ-A☐-3819-S	TJ-P☐-3819-S	TJ-3819P	TJ-3819	160	340
380×190×130	TJ-A☐-3819	TJ-P☐-3819	TJ-3819P	TJ-3819	160	340
380×190×180	TJ-A☐-3819-1	TJ-P☐-3819-1	TJ-3819P	TJ-3819	160	340
280×380×130	TJ-A☐-3828	TJ-P☐-3828	TJ-3828P	TJ-3828	245	345
280×380×180	TJ-A☐-3828-2	TJ-P☐-3828-2	TJ-3828P	TJ-3828	245	345
280×380×230	TJ-A☐-3828-3	TJ-P☐-3828-3	TJ-3828P	TJ-3828	245	345
280×560×130	TJ-A☐-2856	TJ-P☐-2856	TJ-2828P×2	TJ-2856	245	525
380×560×180	TJ-A☐-3856	TJ-P☐-3856	TJ-3828P×2	TJ-3856	245	525

备注：前面带★表示螺丝是不锈钢材质

TE系列塑料盒 (不锈钢搭扣+铰链型)

TE Series Plastic Enclosure(Plastic latch+hinge type)



CE IP66



产品特征

- 1、很容易将箱盖和箱体分开，用户可以非常方便地进行加工和印刷作业；
- 2、铰链与箱体一体设计，链接柱和锁扣等重要部件采用不锈钢材料，非常坚固。且具有防腐性功能；
- 3、抗冲击力强IK07/08；
- 4、采用泡沫橡胶点胶成型。防护等级IP66；
- 5、材料分为ABS和PC两种；
- 6、温度范围-40°C~+80°C。

型号规格 Product Model (Stainless steel latch+Screwtype)			内板型号 Plate Model		金属内板规格 Plate Size	
宽x长x深 WHD	灰色盖ABS/PC		塑料 Plastic	金属 Metal	M1	M2
	灰色盖ABS:☐ 透明盖PC:☐ 灰色箱体ABS Body: Grey ABS	PC 灰色盖PC:☐ 透明盖PC:☐ 灰色箱体PC Body: Grey PC				
100×150×70	TE-A☐-1015	TE-P☐-1015	TJ-1015P	TJ-1015	77	127
100×200×70	TE-A☐-1020	TE-P☐-1020	TJ-1020P	TJ-1020	70	170
110×260×75	TE-A☐-1026-S	TE-P☐-1026-S	-----	TJ-1026	80	230
110×260×100	TE-A☐-1026	TE-P☐-1026	-----	TJ-1026	80	230
135×155×80	TE-A☐-1315	TE-P☐-1315	-----	TJ-1315	110	130
135×185×80	TE-A☐-1318-S	TE-P☐-1318-S	-----	TJ-1318	110	160
135×185×110	TE-A☐-1318	TE-P☐-1318	-----	TJ-1318	110	160
150×150×90	TE-A☐-1515	TE-P☐-1515	TJ-1515P	TJ-1515	120	120
170×220×110	TE-A☐-1722	TE-P☐-1722	TJ-1722P	TJ-1722	148	190
170×270×110	TE-A☐-1727	TE-P☐-1727	-----	TJ-1727	145	240
190×290×140	TE-A☐-1929	TE-P☐-1929	TJ-1929P	TJ-1929	160	260
250×300×150	TE-A☐-2530	TE-P☐-2530	TJ-2530P	TJ-2530	226	275
250×300×180	TE-A☐-2530-1	TE-P☐-2530-1	TJ-2530P	TJ-2530	226	275
250×350×150	TE-A☐-2535-1	TE-P☐-2535-1	TJ-2535P	TJ-2535	215	315
250×350×180	TE-A☐-2535	TE-P☐-2535	TJ-2535P	TJ-2535	215	315
290×190×140	TE-A☐-2919	TE-P☐-2919	TJ-2919P	TJ-2919	260	160
290×390×160	TE-A☐-2939	TE-P☐-2939	TJ-2939P	TJ-2939	245	345
300×300×130	TE-A☐-3030-S	TE-P☐-3030-S	TJ-3030P	TJ-3030	300	300
300×300×180	TE-A☐-3030-A	TE-P☐-3030-A	TJ-3030P	TJ-3030	300	300
350×465×160	TE-A☐-3546	TE-P☐-3546	TJ-3546P	TJ-3546	325	425
350×465×200	TE-A☐-3546-1	TE-P☐-3546-1	TJ-3546P	TJ-3546	325	425
400×500×160	TE-A☐-4050	TE-P☐-4050	TJ-4050P	TJ-4050	358	458
400×500×200	TE-A☐-4050-1	TE-P☐-4050-1	TJ-4050P	TJ-4050	358	458
400×600×180	TE-A☐-4060	TE-P☐-4060	TJ-4060P	TJ-4060	450	555
400×600×230	TE-A☐-4060-1	TE-P☐-4060-1	TJ-4060P	TJ-4060	450	555
530×630×185	TE-A☐-5363-S	-----	-----	TJ-5363	460	560
530×630×255	TE-A☐-5363	-----	-----	TJ-5363	460	560
530×730×185	TE-A☐-5373-S	-----	-----	TJ-5373	460	660
530×730×255	TE-A☐-5373	-----	-----	TJ-5373	460	660
630×830×185	TE-A☐-6383-S	-----	-----	TJ-6383	560	760
630×830×285	TE-A☐-6383	-----	-----	TJ-6383	560	760

TJ系列塑料盒(开关按钮型)

TJ Series Plastic Enclosure(Switch button box)



www.dmlbox.com

Dimension(允许误差 ± 1mm)

防水防尘等级: IP66
温度范围: -40°C ± 120°C

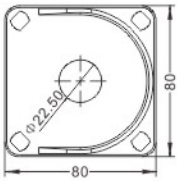

TJ-AG 0808-Q1

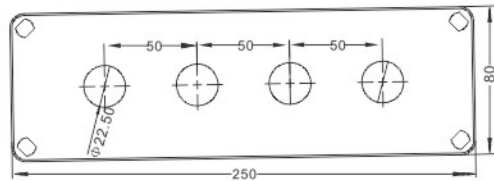

TJ-AG 0825-K4

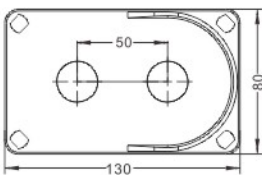

TJ-AG 0813-Q2

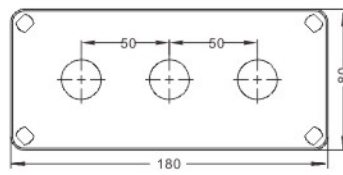

TJ-AG 0818-K3

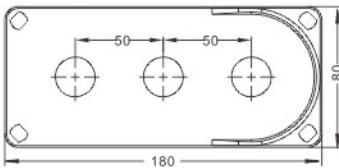

TJ-AG 0818-Q3

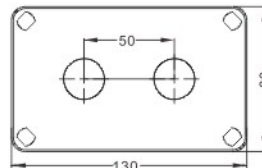

TJ-AG 0813-K2

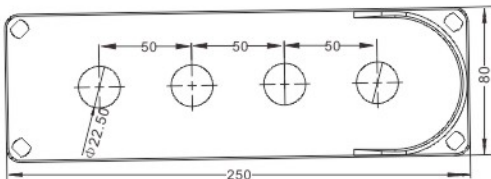

TJ-AG 0825-Q4

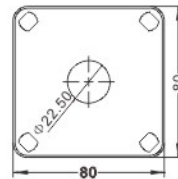

TJ-AG 0808-K1

W H D 宽x长x深 (mm)	产品型号 Product Model
80×80×60	TJ-AG 0808-Q1
80×130×70	TJ-AG 0813-Q2
80×180×70	TJ-AG 0818-Q3
80×250×70	TJ-AG 0825-Q4
80×80×60	TJ-AG 0808-K1
80×130×70	TJ-AG 0813-K2
80×180×70	TJ-AG 0818-K3
80×250×70	TJ-AG 0825-K4



塑料防水箱

AL系列铸铝机箱

AL Series Aluminum Enclosure

RoHS CE IP66



AL系列铸铝盒采用高质量压铸铝合金材料压铸而成。具有结构合理简洁、优秀的抗冲击性能、有效的密封性能和良好的抗电磁干扰的特点。

接线盒内可安装接线端子线路板或其他电气元件，适用于各种自动化领域。

标准配置

箱体、箱盖、盖板、螺丝

工艺特点

- 1.材料：压铸铝合金 AlSi12
- 2.密封条：硅橡胶（可提供特种密封条）
- 3.防护等级：IP66（可提供认证）
- 4.使用环境温度：-50℃至+130℃
- 5.盒盖螺钉：不锈钢十字槽（不易脱落）
- 6.颜色：银灰（可提供特殊颜色）

选 型 表

型号 Model	WHD 宽x长x深 (mm)	金属底板 Metal Plate	金属底板尺寸	
			M1	M2
HY-AL0605	58×64×36	V0605	48.5	54.5
HY-AL0906	64×98×36	V0906	51	85
HY-AL1506	64×150×36	V1506	51	137
HY-AL1106	65×115×55	V1106	51	101
HY-AL0807	77×82×36	V0807	66.5	71.5
HY-AL1208	82×127×57	V1208	72	117
HY-AL1708	80×175×57	V1708	66	161
HY-AL2508	80×250×57	V2508	66	236
HY-AL1010	100×100×80	V1010	88.5	88.5
HY-AL1610-1	100×160×80	V1610-1	84.5	144.5
HY-AL2010	100×200×80	V2010	87	187

型号 Model	WHD 宽x长x深 (mm)	金属底板 Metal Plate	金属底板尺寸	
			M1	M2
HY-AL1212	125×125×80	V1212	110.5	110.5
HY-AL3612	120×360×80	V3612	105	345
HY-AL2212	125×220×80	V2212	112	209
HY-AL2214-2	140×220×90	V2214-2	122	102
HY-AL1616-1	160×160×90	V1616-1	148.5	148.5
HY-AL2616	160×260×90	V2616	147.5	248.5
HY-AL3616	160×360×90	V3616	142.5	342.5
HY-AL2320	230×200×110	V2320	183	213
HY-AL2823	230×280×110	V2823	213	263.5
HY-AL3323-1	230×330×120	V3323-1	212.5	312.5
HY-AL6031	310×600×110	V6031	292	582

铸铝盒的应用

- 1、运用各种场合应用；
- 2、高强度抵抗化学物质侵蚀；
- 3、适合用在有害物质环境、室内、室外及其它与海水频繁接触的地方。



接线端子盒

Terminal block box

四川德米勒电气有限公司



接线端子盒有极好的绝缘性能，抗化学腐蚀和抗机械挤压的性能。达到高要求的IP66防护等级。所有箱体均防尘、防水，能抗80℃高温。产品使用ABS、PC、PBT耐火材料和UV添加材料制成。外形美观大方，具有很高的可塑性和坚固性。接线端子排正常耐压400V，耐高压4KW，正常电流容量0.75mm sq.- 15mm sq. 端子规格有3p-60P多种规格满足您的选择。



接线端子盒



TB-15P-M

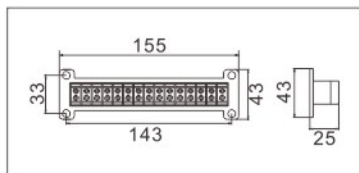

TB-15P-S

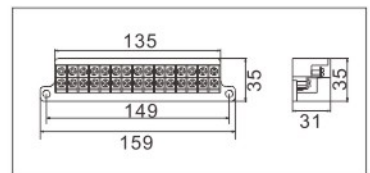

TB-20P-M

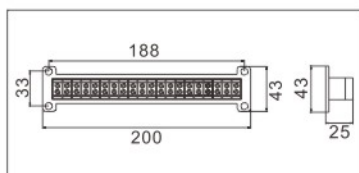

TB-20P-S

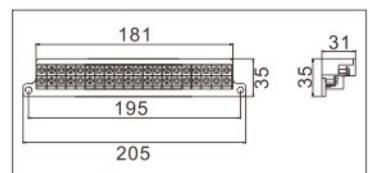

接线端子盒

Terminal block box

TJ-4P,TJ-6P



TJ-4P

TJ-6P

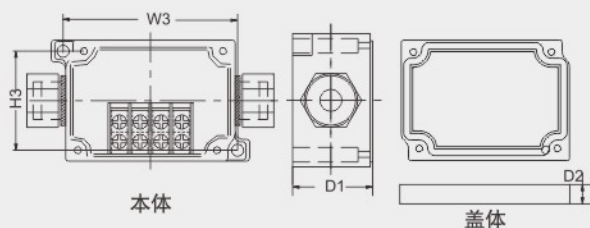

螺杆式 灰色门	外形尺寸(mm)		安装尺寸(mm)	
	W宽xH长xD深	D1+D2	W3	H3
TJ-4P	102 × 50 × 40	33 + 8	72.5	41
TJ-6P	122 × 50 × 40	33 + 8	88	46

TJ-4P-K,TJ-6P-K



TJ-4P-K

TJ-6P-K

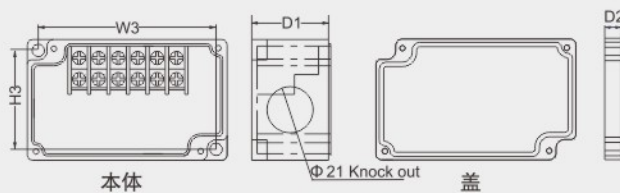

螺杆式 灰色门	外形尺寸(mm)		安装尺寸(mm)	
	W宽xH长xD深	D1+D2	W3	H3
TJ-4P-K	70 × 55 × 43	35 + 8	57.8	41
TJ-6P-K	91 × 55 × 43	35 + 8	81	45

TJ-10P,TJ-15P



TJ-10P

TJ-15P

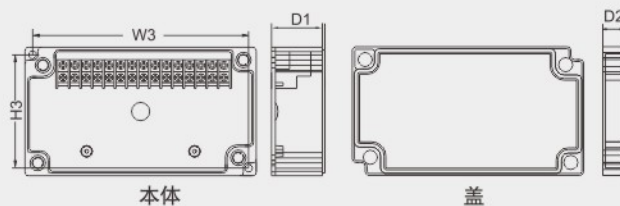

螺杆式 灰色门	外形尺寸(mm)		安装尺寸(mm)	
	W宽xH长xD深	D1+D2	W3	H3
TJ-10P	100 × 75 × 40	32 + 8	100	65
TJ-15P	180 × 110 × 55	39.5 + 16	168	88

接线端子盒

Terminal block box

TJ-20P-S, TJ-15P-S

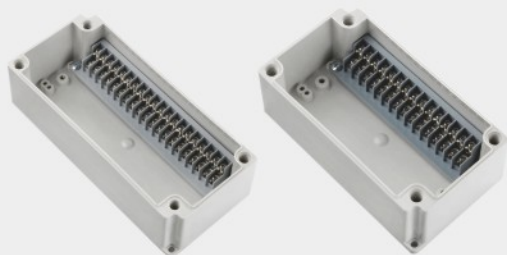

TJ-20P-S

TJ-15P-S

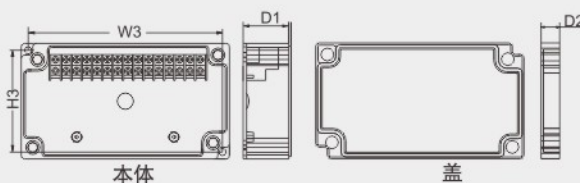

螺杆式 灰色门	外形尺寸(mm)		安装尺寸(mm)	
	W宽xH长xD深	D1+D2	W3	H3
TJ-15P-S	180 × 100 × 75	60 + 16	168	88
TJ-20P-S	223 × 100 × 75	60 + 16	213	92

PBT-3P,PBT-4P,PBT-6P



PBT-3P

PBT-4P

PBT-6P

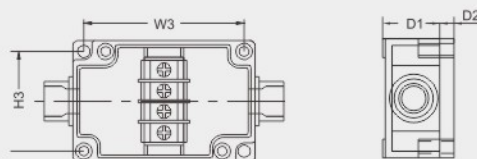

螺杆式 灰色门	外形尺寸(mm)		安装尺寸(mm)	
	W宽xH长xD深	D1+D2	W3	H3
PBT-3P	65 × 33 × 24	19.5 + 4.5	57.8	25.8
PBT-4P	60 × 40 × 24	19.5 + 4.5	52.8	32.8
PBT-6P	70 × 50 × 24	19 + 5	62	42



型号	配置	过线范围
TJ-4P-K-01A	NCA-PG13.5-9x2	5-9mmx2
TJ-4P-K-02A	NCA-PG13.5-12.5x2	6-12.5mmx2
TJ-4P-K-03A	NCA-PG13.5-9x1	5-9mmx1
	NCA-PG13.5-12.5x1	6-12.5mmx1



型号	配置	过线范围
TJ-6P-K-01A	NCA-PG13.5-9x2	5-9mmx2
TJ-6P-K-02A	NCA-PG13.5-12.5x2	6-12.5mmx2
TJ-6P-K-03A	NCA-PG13.5-9x1	5-9mmx1
	NCA-PG13.5-12.5x1	6-12.5mmx1

接线端子盒

Terminal block box



型号	配置	过线范围
TJ-10P-01A	NCA-PG13.5-9x2	5-9mmx2
TJ-10P-02A	NCA-PG13.5-12.5x2	6-12.5mmx2
TJ-10P-03A	NCA-PG13.5-9x1	5-9mmx1
	NCA-PG13.5-12.5x1	6-12.5mmx1



型号	配置	过线范围
TJ-15P-S-01A	NCA-PG13.5-9x2	5-9mmx2
	NCA-PG13.5-12.5x2	6-12.5mmx2



型号	配置	过线范围
TJ-20P-S-01A	NCA-PG29-21x1	14-22mmx1
	NCA-PG21-17.5x1	12.5-18mmx1



型号	配置	过线范围
TJ-15P-SX2-01A	NCA-PG21-17.5x1	12.5-18mmx1
	NCA-PG21-17.5x1	7-13mmx1

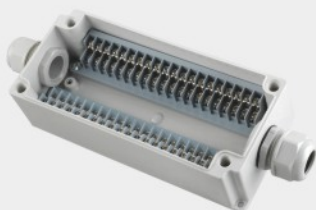

型号	配置	过线范围
TJ-20P-SX2-01A	NCA-PG21-21x1	14-22mmx1
	NCA-PG21-17.5x1	12.5-18mmx1

以上部分应用，可根据客户要求定制



悬臂控制箱



立式操作箱



产品特征

- 1、由高品质阳极氧化铝型材和铝压铸部件拼接而成。简洁外观设计，结构稳固。表面阳极氧化的铝型材易于擦拭。始终保持箱体光亮如新；
- 2、广泛用于数控机床。装配代及专用设备上各类人机界面和附件的安装，配合悬臂式或支撑系统，箱体尺寸完全按照需求定制；
- 3、除铝操作箱外，我司还提供冷轧钢和不锈钢304材料箱体。

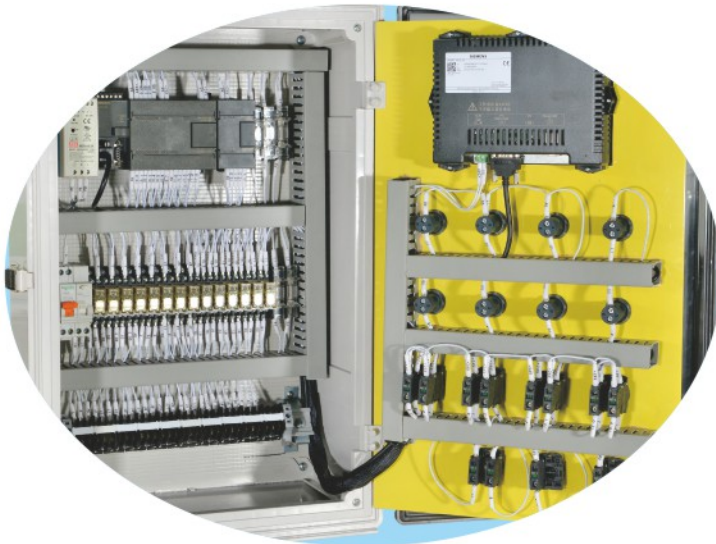

产品特征

防水配电箱适用于50Hz,660V以下,负荷电流大于225A的三相三线、三相四线、三相五线控制系统,对配电系统作控制、漏电保护及电动机的过载、短路、缺相保护及各种控制,该箱体设计合理,外型美观、防护等级高,使用安全可靠,广泛用于机械设备工业自动化冶金、石化、医疗卫生、航空、住宅小区、商场、学校、城市建筑等行业。

AR9系列落地式机柜

AR9 series Floor Type Cabinet



CE IP65



更快 更准 更稳



四川德米勒电气有限公司

落地式机柜

标准配置：封闭箱体

标准前门（带加强筋）

文件袋

材料：冷轧钢

表面处理：热固粉末涂层 波纹饰面

颜色：RAL 7035

型号	宽x长x深(mm) WHD	前门 板厚度 (mm)	后/侧门 板厚度 (mm)	型材 厚度 (mm)	底板 厚度 (mm)	适用开孔 类型	货期
AR9 186/4	600 × 1800 × 400	1.5	1.5	1.5	2.5	□□☆	5 - 7 天
AR9 188/6	800 × 1800 × 600	1.5	1.5	1.5	2.5	□□☆	
AR9 208/6	800 × 2000 × 600	1.5	1.5	1.5	2.5	□□☆	
AR9 208/8	800 × 2000 × 800	1.5	1.5	1.5	2.5	□□☆	
AR9 2012/6	1200 × 2000 × 600	1.5	1.5	1.5	2.5	□□☆	

标准配件

深度导轨



型号	深度导轨(mm)			
	WD400	WD500	WD600	WD800
尺寸	400	500	600	800
只/套	4	4	4	4
型号	WW600	WW800	WW1000	WW1200
尺寸	600	800	1000	1200
只/套	4	4	4	4



A4 文件夹
型号：PP100



吊环WA 065
型号WA 065



机柜锁
型号：MS830

底板尺寸

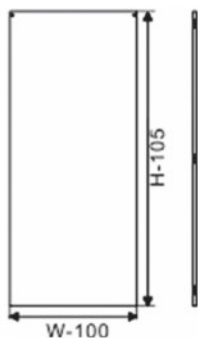

AR9分解图



ST系列挂墙式机箱

ST Series Wall Hanging Case



CE IP65



更快 更准 更稳



标准配置：封闭箱体
 镀锌安装底板
 锁
 进线封板
 密封圈及安装附件

材料：冷轧钢

表面处理：热固粉末涂层 波纹饰面

颜色：RAL 7035

进线孔类型	型号	宽x长x深(mm) WxHxD	门板厚度 (mm)	箱体厚度 (mm)	底板厚度 (mm)	适用开孔类型	货期
A	ST2 315	200×300×150	1.2	1.2	1.5	□□☆	5-7天
B	ST3 320	300×300×200	1.2	1.2	1.5	◇□☆	
B	ST3 415	300×400×150	1.2	1.2	1.5	□□☆	
B	ST3 420	300×400×200	1.2	1.2	1.5	◇□☆	
C	ST4 420	300×400×200	1.2	1.2	1.5	□□☆	
C	ST4 520	400×500×150	1.2	1.2	1.5	□□☆	
B	ST4 515	400×500×200	1.2	1.2	1.5	□□☆	
C	ST4 620	400×600×200	1.2	1.2	1.5	□□☆	
C	ST4 525	400×500×250	1.2	1.2	1.5	◇□☆	
D	ST5 620	500×600×200	1.2	1.2	1.5	□□☆	
D	ST6 820	500×800×200	1.5	1.5	2	□□☆	
D	ST6 830	600×800×300	1.5	1.5	2	◇□☆	

进线孔尺寸

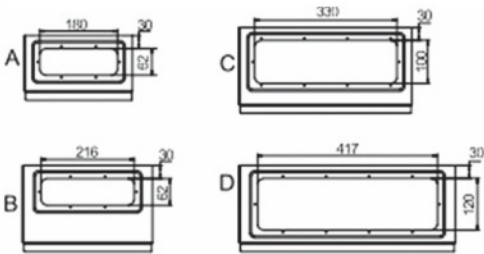

底板尺寸

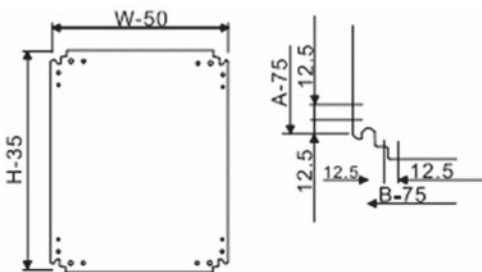

接地线
 型号：TJ-CM6130.length 130×Φ6.4
 TJ-CM6160.length 160×Φ6.4



挂墙钩
 型号：WC 010



WA 080 抱箱
 型号：WA 080

www.dmlbox.com

挂墙式机箱



机柜照明灯采用LED光源，使用寿命长达5000H，外配用闪光灯罩。光线柔和均匀，安装方便快捷，适用于各种中小型机器照明，可选配限位开关。

主要功能及特点

- 专业机柜照明设计，可靠性高
- LED光源，使用寿命超长
- 灯罩采用PC材料，光线分布更加均匀柔和
- 配合门位开关使用，安装方便灵活
- 外观设计精巧大气，节省柜内空间

安装尺寸及接线示意图（单位mm）

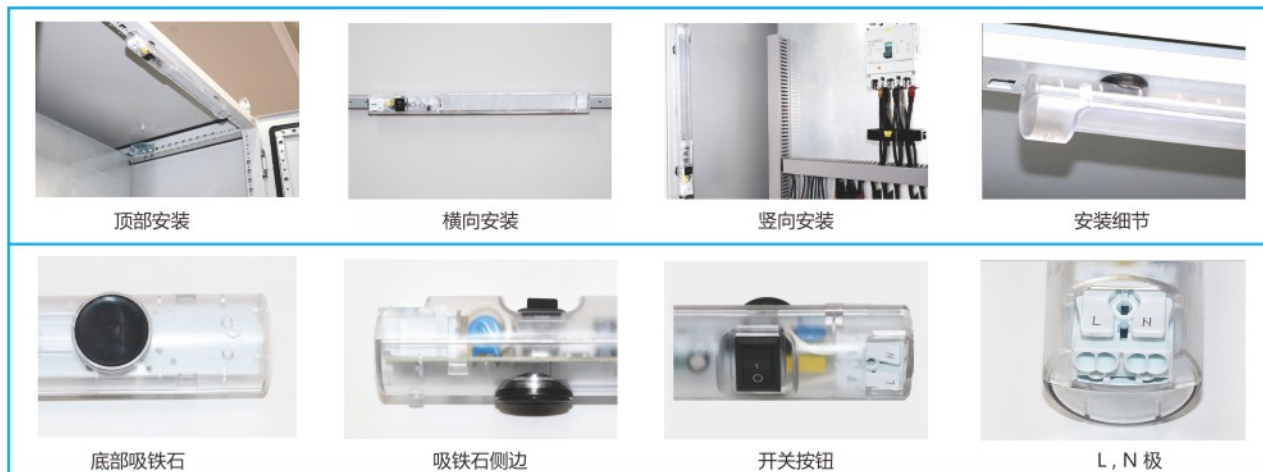
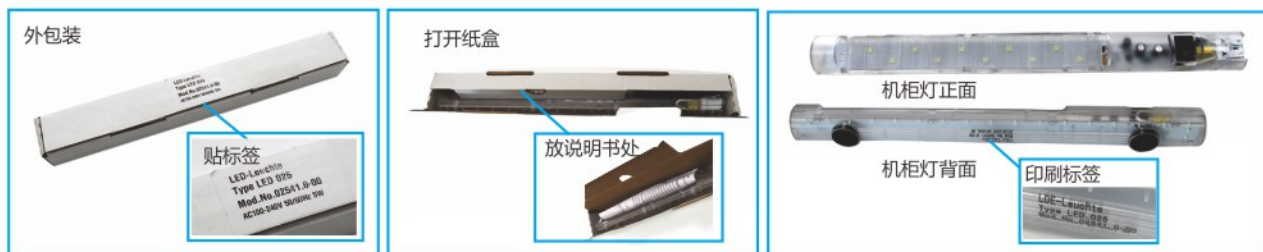

标准型AF16S系列 (16mm)



□ 头部颜色

颜色	■	■	■	■	■	■	■
代号	R	G	Y	B	W	A	BL

电压	6V	12V	24V	48V	110V	220V
代号	01	02	03	04	05	06

开关类型	头部	特性	型号
自复按钮	圆形	无灯	AF164YS-11/ ■ ■ ■ ■
	方形		AF164FS-11/□□□□
	矩形		AF164JS-11/□□□□
	圆形	带灯	AF164YS-11D/□□□□
	方形		AF164FS-11D/□□□□
	矩形		AF164JS-11D/□□□□
自锁按钮	圆形	自锁无灯	AF164YS-11T/□□□□
	方形		AF164FS-11T/□□□□
	矩形		AF164JS-11T/□□□□
	圆形	自锁带灯	AF164YS-11TD/□□□□
	方形		AF164FS-11TD/□□□□
	矩形		AF164JS-11TD/□□□□

标准型AF16S系列 (16mm)

开关类型	头部	特性		型号
旋钮	圆形旋钮	二位置	自复	AF164YS-11X/圆 色 电 压
			自锁	AF164YS-11XT/□□□□
			自复	AF164FS-11X/□□□□
	自锁		AF164FS-11XT/□□□□	
	自复		AF164JS-11X/□□□□	
	自锁		AF164JS-11XT/□□□□	
	方形旋钮	三位置	自复	AF164YS-11XS/□□□□
			自锁	AF164YS-11XST/□□□□
			左锁	AF164YS-11XST/L/□□□□
	右锁		AF164YS-11XST/R/□□□□	
	自复		AF164FS-11XS/□□□□	
	自锁		AF164FS-11XST/□□□□	
	矩形旋钮	三位置	左锁	AF164FS-11XST/L/□□□□
			右锁	AF164FS-11XST/R/□□□□
			自复	AF164JS-11XS/□□□□
自锁	AF164JS-11XST/□□□□			
左锁	AF164JS-11XST/L/□□□□			
右锁	AF164JS-11XST/R/□□□□			
蘑菇钮	圆形蘑菇钮	自复		AF164YS-11M/□□□□
	方形蘑菇钮			AF164FS-11M/□□□□
	巨形蘑菇钮			AF164JS-11M/□□□□
	圆形蘑菇钮	自锁		AF164YS-11MT/□□□□
	方形蘑菇钮			AF164FS-11MT/□□□□
	巨形蘑菇钮			AF164JS-11MT/□□□□
指示灯	圆形信号灯			AF165YS-D/□□□□
	方形信号灯			AF165FS-D/□□□□
	巨形信号灯			AF165JS-D/□□□□
钥匙钮	圆形	二位置	自复	AF164YS-11Y/□□□□
			自锁	AF164YS-11YT/□□□□
			自复	AF164FS-11Y/□□□□
	自锁		AF164FS-11YT/□□□□	
	自复		AF164JS-11Y/□□□□	
	自锁		AF164JS-11YT/□□□□	
	方形	三位置	自复	AF164YS-11YS/□□□□
			自锁	AF164YS-11YST/□□□□
			左锁	AF164YS-11YST/L/□□□□
	右锁		AF164YS-11YST/R/□□□□	
	自复		AF164FS-11YS/□□□□	
	自锁		AF164FS-11YST/□□□□	
	矩形	三位置	左锁	AF164FS-11YST/L/□□□□
			右锁	AF164FS-11YST/R/□□□□
			自复	AF164JS-11YS/□□□□
自锁	AF164JS-11YST/□□□□			
左锁	AF164JS-11YST/L/□□□□			
右锁	AF164JS-11YST/R/□□□□			
巨形	三位置	自复	AF164YS-11YS/□□□□	
		自锁	AF164YS-11YST/□□□□	
		左锁	AF164YS-11YST/L/□□□□	
右锁		AF164YS-11YST/R/□□□□		
自复		AF164FS-11YS/□□□□		
自锁		AF164FS-11YST/□□□□		
紧急钮	直径27mm	低位		AF1652-02/11Z/□□□□
	直径32mm	低位		AF1653-02/11Z/□□□□
	直径32mm	警示圈	无灯	AF164YS-11Z/□□□□
带灯	AF164YS-11ZD/□□□□			

面板式AF16B系列(19mm)



□ 头部颜色

颜色	■	■	■	■	■	■	■
代号	R	G	Y	B	W	A	BL

电压	6V	12V	24V	48V	110V	220V
代号	01	02	03	04	05	06

开关类型	头部	特性	型号
自复按钮	圆形	无灯	AF164YB-11/圆形电圈
	方形		AF164FB-11/□□□□
	矩形		AF164JB-11/□□□□
	圆形	带灯	AF164YB-11D/□□□□
	方形		AF164FB-11D/□□□□
	矩形		AF164JB-11D/□□□□
自锁按钮	圆形	自锁无灯	AF164YB-11T/□□□□
	方形		AF164FB-11T/□□□□
	矩形		AF164JB-11T/□□□□
	圆形	自锁带灯	AF164YB-11TD/□□□□
	方形		AF164FB-11TD/□□□□
	矩形		AF164JB-11TD/□□□□

面板式AF16B系列(19mm)

开关类型	形状	特征	型号	
旋钮	圆形旋钮	二位置	自复	AF164YB-11X/颜色电压
			自锁	AF164YB-11XT/□□□□
			自复	AF164FB-11X/□□□□
	自锁		AF164FB-11XT/□□□□	
	自复		AF164JB-11X/□□□□	
	自锁		AF164JB-11XT/□□□□	
	方形旋钮	三位置	自复	AF164YB-11XS/□□□□
			自锁	AF164YB-11XST/□□□□
			左锁	AF164YB-11XST/L/□□□□
	右锁		AF164YB-11XST/R/□□□□	
	自复		AF164FB-11XS/□□□□	
	自锁		AF164FB-11XST/□□□□	
	矩形旋钮	三位置	左锁	AF164FB-11XST/L/□□□□
			右锁	AF164FB-11XST/R/□□□□
			自复	AF164JB-11XS/□□□□
自锁	AF164JB-11XST/□□□□			
左锁	AF164JB-11XST/L/□□□□			
右锁	AF164JB-11XST/R/□□□□			
指示灯	圆形信号灯	AF165YB-D/□□□□		
	方形信号灯	AF165FB-D/□□□□		
	巨形信号灯	AF165JB-D/□□□□		
钥匙钮	圆形	二位置	自复	AF164YB-11Y/□□□□
			自锁	AF164YB-11YT/□□□□
			自复	AF164FB-11Y/□□□□
	自锁		AF164FB-11YT/□□□□	
	自复		AF164JB-11Y/□□□□	
	自锁		AF164JB-11YT/□□□□	
	方形	三位置	自复	AF164YB-11YS/□□□□
			自锁	AF164YB-11YST/□□□□
			左锁	AF164YB-11YST/L/□□□□
	右锁		AF164YB-11YST/R/□□□□	
	自复		AF164FB-11YS/□□□□	
	自锁		AF164FB-11YST/□□□□	
	巨形	三位置	左锁	AF164FB-11YST/L/□□□□
			右锁	AF164FB-11YST/R/□□□□
			自复	AF164JB-11YS/□□□□
自锁	AF164JB-11YST/□□□□			
左锁	AF164JB-11YST/L/□□□□			
右锁	AF164J-11YST/R/□□□□			

大操作面板式AF16L系列(22mm)



□ 头部颜色

颜色	■	■	■	■	■	■	■
代码	R	G	Y	B	W	A	BL

电压	6V	12V	24V	48V	110V	220V
代号	01	02	03	04	05	06

开关类型	头部	特性		型号
自复按钮	嵌入式	无灯		AF167LF-11/□□□□
	凸头式			AF167LE-11/□□□□
	嵌入式	带灯		AF167LF-11D/□□□□
	凸头式			AF167LE-11D/□□□□
自锁按钮	嵌入式	自锁无灯		AF167LF-11T/□□□□
	凸头式			AF167LE-11T/□□□□
	嵌入式	自锁带灯		AF167LF-11TD/□□□□
	凸头式			AF167LE-11TD/□□□□
旋钮	嵌入式	二位置	自复	AF167LF-11X/□□□□
			自锁	AF167LF-11XT/□□□□
			自复	AF167LE-11X/□□□□
			自锁	AF167LE-11XT/□□□□
	嵌入式	三位置	自复	AF167LF-11XS/□□□□
			自锁	AF167LF-11XST/□□□□
			左锁	AF167LF-11XST/L/□□□□
			右锁	AF167LF-11XST/R/□□□□
			自复	AF167LE-11XS/□□□□
			自锁	AF167LE-11XST/□□□□
			左锁	AF167LE-11XST/L/□□□□
			右锁	AF167LE-11XST/R/□□□□
凸头式				
指示灯	嵌入式			AF167LF-D/□□□□
	凸头式			AF167LE-D/□□□□
钥匙钮	嵌入式	二位置	自复	AF167LF-11Y/□□□□
			自锁	AF167LF-11YT/□□□□
			自复	AF167LE-11Y/□□□□
			自锁	AF167LE-11YT/□□□□
	嵌入式	三位置	自复	AF167LF-11YS/□□□□
			自锁	AF167LF-11YST/□□□□
			左锁	AF167LF-11YST/L/□□□□
			右锁	AF167LF-11YST/R/□□□□
			自复	AF167LE-11YS/□□□□
			自锁	AF167LE-11YST/□□□□
			左锁	AF167LE-11YST/L/□□□□
			右锁	AF167LE-11YST/R/□□□□
凸头式				
紧急钮	直径32mm	警示圈	无灯	AF167LF-11Z/□□□□
			带灯	AF167LF-11ZD/□□□□

□ 头部颜色

颜色							
代码	R	G	Y	B	W	A	BL

电压	6V	12V	24V	48V	110V	220V
代号	01	02	03	04	05	06

产品图片	产品名称	产品型号	安装尺寸
	22mm 金属按钮环带 灯带电源标识	S22FM-11/□□□□	Φ22mm
	22mm 金属按钮环形带灯	S22FU-11L/□□□□	Φ22mm
	27mm 紧急钮	S22D-11Z/□□□□	Φ22mm
		S22D-02Z/□□□□	
	22mm 指示灯 (三色)	S22F-D3/□□□□	Φ22mm
	22mm 指示灯	AF16LF-D/□□□□	Φ22mm
	8mm 指示灯	MF8-D/□□□□	Φ22mm

以上产品，全部可以带上所需要的标识

尼龙电缆固定头MG,PG

ROHS CE IP68



www.dmlbox.com

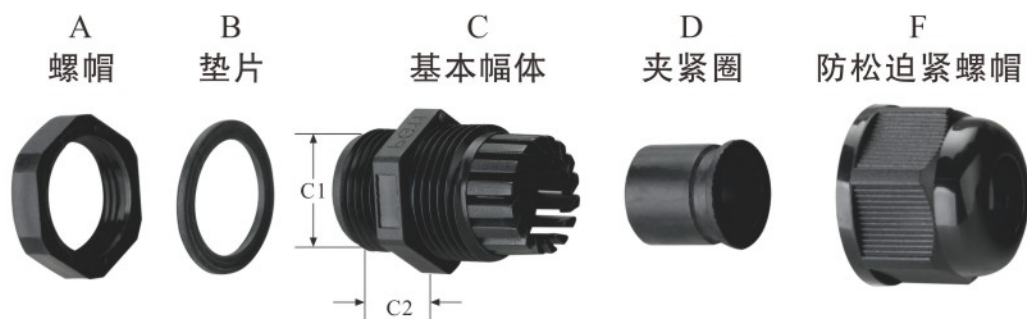

螺牙规格: 公制牙(Metric), 德制牙PG, 符合欧盟规范。

产品材质: A.C.F部分采用UL认可之尼龙PA66(防火等级UL94V-2)制成;(可定制UL认可的V-0防火等级尼龙原料);

B.D部分采用三元乙丙耐候橡胶制成。(可定制耐寒、耐高温橡胶;耐高酸碱、耐化学与抗腐蚀橡胶)

保护等级: IP68

工作温度: 静态-40°C至100°C,或瞬间可耐热至120°C,动态-20°C至80°C,或瞬间可耐热至100°C

产品特性: 特殊夹紧爪与夹紧圈之设计.夹紧电缆范围大.抗拉力特强,可防水、防尘、抗盐、耐弱酸、酒精、油油脂及一般溶剂。

颜色种类: 黑色、灰色.其它颜色可定做

尼龙电缆固定头MG,PG

RoHS CE IP68

产品型号 Product Model	螺牙规格 Thread	电缆范围 Cable Range Φ(mm)	螺纹外径 Thread O.D. C1(mm)	螺纹长度 Thread Length C2(mm)	扳手径 Spanner Size A&F(mm)	包装 Std.Pkg (pcs)	
NCA-M8-4.8	M8x1.25	2-4.8	8	7.5	13/12	50	
NCA-M10-6	M10x1.5	2.5-6	10	8	15/13	50	
NCA-M12S-6	M12x1.5	3-6.5	12	8.5	18/15	50	
NCA-M12SL-6		3-6.5	12	15	18/15	50	
NCA-M12-5		3-5.5	12	8.5	18/19	50	
NCA-M12-7		4-8	12	8.5	18/19	50	
NCA-M12L-5		3-5.5	12	15	18/19	50	
NCA-M12L-7		4-8	12	15	18/19	50	
NCA-M16S-8		M16x1.5	4-8	16	10	22/19	50
NCA-M16SL-8			4-8	16	15	22/19	50
NCA-M16-7	3-7		16	10	22/22	50	
NCA-M16-10	5-10		16	10	22/22	50	
NCA-M16L-7	3-7		16	15	22/22	50	
NCA-M16L-10	5-10		16	15	22/22	50	
NCA-M18-7	M18x1.5		3-7	18	10	24/22	50
NCA-M18-10		5-10	18	10	24/22	50	
NCA-M18L-7		3-7	18	15	24/22	50	
NCA-M18L-10		5-10	18	15	24/22	50	
NCA-M20S-12.5	M20x1.5	6-12.5	20	10	27/24	50	
NCA-M20-11		5-11	20	11	27/27	50	
NCA-M20-13.5		8.5-14	20	11	27/27	50	
NCA-M20L-11		5-11	20	15	27/27	50	
NCA-M20L-13.5		8.5-14	20	15	27/27	50	
NCA-M22-11	M22x1.5	5-11	22	11	27/27	50	
NCA-M22-13.5		8.5-14	22	11	27/27	50	

四川德米勒电气有限公司

电气辅材

产品型号 Product Model	螺牙规格 Thread	电缆范围 Cable Range Φ(mm)	螺纹外径 Thread O.D. C1(mm)	螺纹长度 Thread Length C2(mm)	扳手径 Spanner Size A&F(mm)	包装 Std.Pkg (pcs)
NCA-M24-11	M24x1.5	5-11	24	11	27/27	50
NCA-M24-13.5		8.5-14	24	11	27/27	50
NCA-M24-11		5-11	24	11	27/27	50
NCA-M24-13.5		8.5-14	24	11	27/27	50
NCA-M25S-14	M25x1.5	8.5-14	25	11.6	33/27	50
NCA-M25-13		7-13	25	11.6	33/33	50
NCA-M25-18		12.5-18	25	11.6	33/33	50
NCA-M25L-13		7-13	25	15	33/33	50
NCA-M25L-18		12.5-18	25	15	33/33	50
NCA-M32S-17.5	M32x1.5	11-17.5	32	15	36/42	20
NCA-M32-22		14-22	32	15	41/42	20
NCA-M32-25		17-25	32	15	41/42	20
NCA-M36-22	M36x1.5	14-22	36	12	45/42	20
NCA-M36-25		17-25	36	12	45/42	20
NCA-M40-26.5	M40x1.5	18-25	40	15	50/52	10
NCA-M40-31		23-32	40	15	50/52	10
NCA-M50-32	M50x1.5	25-32	50	15	62/62	10
NCA-M50-41		30-41	50	15	62/62	10
NCA-M63-41	M63x1.5	29-38	63	18	75/65	10
NCA-M63-46		35-46	63	18	75/65	10
NCA-PG7S-6	PG7	3-6.5	12.5	8	17/15	50
NCA-PG7-5		3-5.5	12.5	8	17/19	50
NCA-PG7-7		4-8	12.5	8	17/19	50
NCA-PG9-5.5	PG9	3-5.5	15.2	8.2	22/19	50
NCA-PG9-7.5		4-8	15.2	8.2	22/19	50
NCA-PG11-7	PG11	3-7	18.6	10	24/22	50
NCA-PG11-10		5-10	18.6	10	24/22	50
NCA-PG13.5-9	PG13.5	5-9	20.4	10	27/24	50
NCA-PG13.5-12.5		6-12.5	20.4	10	27/24	50
NCA-PG16-11	PG16	5-11	22.5	10.8	30/27	50
NCA-PG16-14		8.5-14	22.5	10.8	30/27	50
NCA-PG19-11	PG19	5-11	23.5	11	30/27	50
NCA-PG19-14		8.5-14	23.5	11	30/27	50
NCA-PG21-15.5	PG21	7-13	28.3	12	36/33	50
NCA-PG21-17.5		12.5-18	28.3	12	36/33	50
NCA-PG25-20	PG25	14-20	30	13	36/37	50
NCA-PG29-21	PG29	14-22	37	12	46/41	20
NCA-PG29-24		17-25	37	12	46/41	20
NCA-PG36-25.5	PG36	17-25.5	47	14	57/52	10
NCA-PG36-31		24-32	47	14	57/52	10
NCA-PG42-32	PG42	25-32	54	15	64/62	10
NCA-PG42-41		30-41	54	15	64/62	10
NCA-PG48-38	PG48	29-38	59.3	15.5	70/65	10
NCA-PG48-45.5		35-45.5	59.3	15.5	70/65	10



螺牙规格: 公制牙MG, 德制牙PG, 符合欧盟规范.

产品材质: A.C.F部分以黄铜镀镍制成, E部分以UL认可之尼龙PA66制成(防火等级UL94V-2), B.D部分采用EPDM耐候橡胶制成。(可定制耐寒耐高酸碱、耐化学与抗腐蚀橡胶).

保护等级: IP68

工作温度: 静态-40°C至100°C, 或瞬间可耐热至120°C; (可定制-60°C至220°C)

产品特性: 特殊夹紧爪与夹紧圈之设计. 夹紧电缆范围大. 抗拉力特强, 可防水、防尘、抗盐、耐弱酸、酒精、油、油脂及一般溶剂。

金属电缆固定头MG, PG型

产品型号 Product Model	螺牙规格 Thread	电缆范围 Cable Range Φ(mm)	螺纹外径 Thread O.D. C1(mm)	螺纹长度 Thread Length C2(mm)	扳手径 Spanner Size A&F(mm)	包装 Std.Pkg (pcs)
MCJ-PG7S-5.5	PG7	3-6.5	12.5	7	14/14	20
MCJ-PG7-5.5		3-5.5	12.5	8	18/18	10
MCJ-PG7-7.8		4.5-8	12.5	8	18/18	10
MCJ-PG7S-5.5-L		3-6.5	12.5	15	14/14	20
MCJ-PG7-5.5-L		3-5.5	12.5	15	18/18	10
MCJ-PG7-7.8-L		4.5-8	12.5	15	18/18	10
MCJ-PG9-5.5	PG9	3-5.5	15.2	8	18/18	10
MCJ-PG9-7.8		4.5-8	15.2	8	18/18	10
MCJ-PG9-5.5-L		3-5.5	15.2	15	18/18	10
MCJ-PG9-7.8-L		4.5-8	15.2	15	18/18	10
MCJ-PG11-7	PG11	4-7	18.6	9	22/22	10
MCJ-PG11-10		6-10	18.6	9	22/22	10
MCJ-PG11-7-L		4-7	18.6	15	22/22	10
MCJ-PG11-10-L		6-10	18.6	15	22/22	10
MCJ-PG13.5-8.8	PG13.5	4-8.8	20.4	9.5	24/24	10
MCJ-PG13.5-12.5		7-12.5	20.4	9.5	24/24	10
MCJ-PG13.5-8.8-L		4-8.8	20.4	15	24/24	10
MCJ-PG13.5-12.5-L		7-12.5	20.4	15	24/24	10
MCJ-PG16-11	PG16	7-11	22.5	9.5	25/25	10
MCJ-PG16-14		9-14	22.5	9.5	25/25	10
MCJ-PG16-11-L		7-11	22.5	15	25/25	10
MCJ-PG16-14-L		9-14	22.5	15	25/25	10
MCJ-PG21-16	PG21	12-16	28.3	12	30/30	10
MCJ-PG21-18		14-18	28.3	12	30/30	10
MCJ-PG21-16-L		12-16	28.3	15	30/30	10
MCJ-PG21-18-L		14-18	28.3	15	30/30	10
MCJ-PG29-22	PG29	16-22	37	12.5	40/40	10
MCJ-PG29-25		18-25	37	12.5	40/40	10
MCJ-PG29-22-L		16-22	37	15	40/40	10
MCJ-PG29-25-L		18-25	37	15	40/40	10
MCJ-PG36-26	PG36	21-26	47	15	50/50	10
MCJ-PG36-31		24-31	47	15	50/50	10
MCJ-PG42-33	PG42	25-33	54	15	59/59	10
MCJ-PG42-41		31-41	54	15	59/59	10
MCJ-PG48-45	PG48	35-45	59.3	17	69/69	5
MCJ-M6-3.0	M6x1	2-3.0	6	5	9-9	20
MCJ-M8-5	M8x1.25	3-4.8	8	5.5	11-11	20
MCJ-M10-5.5	M10x1.5	3-5.5	10	7	14/14	20
MCJ-M12S-5.5	M12x1.5	3-6.5	12	7	14/14	20
MCJ-M12-5.5		3-5.5	12	8	18/18	10
MCJ-M12-7.8		4.5-8	12	8	18/18	10
MCJ-M12S-5.5-L		3-6.5	12	15	14/14	20
MCJ-M12-5.5-L		3-5.5	12	15	18/18	10
MCJ-M12-7.8-L		4.5-8	12	15	18/18	10
MCJ-M16S-5.5	M16x1.5	3-5.5	16	8	18/18	10
MCJ-M16S-7.8		4.5-8	16	8	18/18	10
MCJ-M16-7		4-7	16	8	22/22	10
MCJ-M16-10		6-10	16	8	22/22	10
MCJ-M16S-5.5-L		3-5.5	16	15	18/18	10
MCJ-M16S-7.8-L		4.5-8	16	15	18/18	10
MCJ-M16-7-L		4-7	16	15	22/22	10
MCJ-M16-10-L		6-10	16	15	22/22	10

波纹管快速接头MG, PG型

RoHS CE IP68

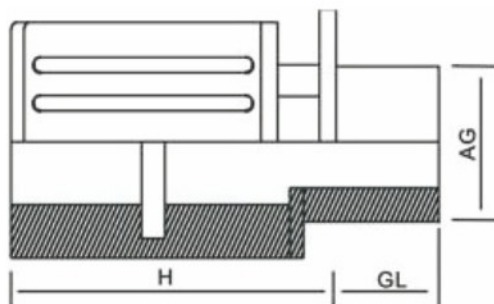

螺牙规格: 公制牙MG, 德制牙PG

产品材质: 采用UL认可之尼龙PA66原料制成

产品颜色: 黑色(B)、灰色(G)其它颜色可以定做。

工作温度: -40°C ~ +85°C

产品特性: 内锁扣合本体特殊设计, 装卸只需拨插

适用方法: 该产品可接入设备箱体上, 也可以根据选用螺纹径接入出口为内螺纹的电动设备上, 只需波纹管插入接口即可

产品型号 Product Model	适配软管 Accommodated Pipes	螺牙规格 Thread	螺纹外径 AG Outer diameter(mm)	螺纹长度 Thread Length GL(mm)	包装 Std. Pkg (pcs)
BQC-M12-10.0	AD10.0	M12x1.5	12	8.5	50
BQC-M12-13.0	AD13.0	M12x1.5	12	10	50
BQC-M16-13.0		M16x1.5	16	10	50
BQC-M18-13.0		M18x1.5	18	10	50
BQC-M16-15.8	AD15.8	M16x1.5	16	10	50
BQC-M18-15.8		M18x1.5	18	12.5	50
BQC-M20-15.8		M20x1.5	20	12.5	50
BQC-M20-18.5	AD18.5	M20x1.5	20	12.5	50
BQC-M22-18.5		M22x1.5	22	12.5	50
BQC-M20-21.2	AD21.2	M20x1.5	20	13	50
BQC-M24-21.2		M24x1.5	24	13	50
BQC-M25-21.2		M25x1.5	25	13	50
BQC-M25-25.0	AD25.0	M25x1.5	25	13	50
BQC-M25-28.5	AD28.5	M25x1.5	25	13	20
BQC-M27-28.5		M27x1.5	27	13	20
BQC-M30-28.5		M30x1.5	30	13	20
BQC-M32-28.5		M32x1.5	32	13	20
BQC-M32-34.5		M32x1.5	32	14	10
BQC-M36-34.5	AD34.5	M36x1.5	36	14	10
BQC-M40-34.5		M40x1.5	40	14	10
BQC-M40-42.5	AD42.5	M40x1.5	40	15	8
BQC-M48-42.5		M48x1.5	48	15	8
BQC-M50-54.5	AD54.5	M50x1.5	50	16	5
BQC-M60-54.5		M60x2.0	60	16	5
BQC-PG7-10.0	AD10.0	PG7	12.5	8.5	50
BQC-PG9-13.0	AD13.0	PG9	15.2	10	50
BQC-PG11-15.8	AD15.8	PG11	18.4	12.5	50
BQC-PG13.5-18.5	AD18.5	PG13.5	20.4	12.5	50
BQC-PG16-21.2	AD21.2	PG16	22.5	13	50
BQC-PG21-28.5	AD28.5	PG21	28.3	13	20
BQC-PG29-34.5	AD34.5	PG29	37	14	10
BQC-PG36-42.5	AD42.5	PG36	47	15	8
BQC-PG42-54.5	AD54.5	PG42	54	16	5
BQC-PG48-54.5	AD54.5	PG48	59.3	16	5

波纹管直角接头MG, PG型

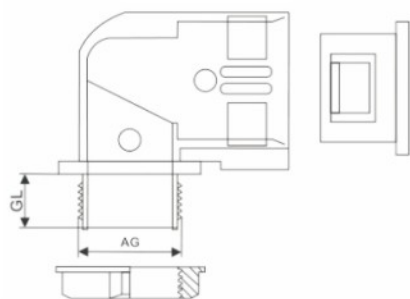

螺牙规格：公制牙MG、德制牙PG、符合欧盟规范；

产品材质：采用UL认可之尼龙PA66原料制成；

产品颜色：黑色(B)、灰色(G)其它颜色可以定做；

工作温度：-40°C~+85°C

产品特性：内锁扣合本体特殊设计，装卸只需拨插；

适用方法：该产品可接入设备箱体上，也可以根据选用螺纹接入出口为内螺纹的电动设备上,只需浪管插入接口即可。

产品型号 Product Model	适配软管 Accommodated Pipes	螺牙规格 Thread	螺纹外径 AG Outer diameter(mm)	螺纹内径 AG Inner diameter(mm)	螺纹长度 Thread Length GL(mm)
CRA-M12-10.0	AD10.0	M12x1.5	12.0	9.0	10.0
CRA-M16-10.0	AD11.6	M16x1.5	16.0	11.0	10.0
CRA-M16-13.0	AD13.0	M16x1.5	16.0	11.6	10.0
CRA-M18-13.0		M18x1.5	18.0	10.0	10.0
CRA-M20-13.0		M20x1.5	20.0	13.0	10.0
CRA-M16-15.8	AD15.8	M16x1.5	16.0	12.0	10.0
CRA-M18-15.8		M18x1.5	18.0	12.0	10.0
CRA-M20-15.8		M20x1.5	20.0	15.0	10.0
CRA-M20-18.5	AD18.5	M20x1.5	20.0	16.0	11.5
CRA-M20-21.2	AD21.2	M20x1.5	20.0	15.0	13.0
CRA-M24-21.2		M24x1.5	24.0	17.0	13.0
CRA-M25-21.2		M25x1.5	25.0	16.0	13.0
CRA-M25-25.0	AD25.0	M25x1.5	25.0	19.5	13.0
CRA-M25-28.5	AD28.5	M25x1.5	25.0	19.5	13.0
CRA-M27-28.5		M27x2.0	27.0	23.0	13.0
CRA-M30-28.5		M30x2.0	30.0	23.0	13.0
CRA-M32-34.5	AD34.5	M32x1.5	32.0	27.0	14.5
CRA-M36-34.5		M36x2.0	36.0	29.0	14.5
CRA-M40-34.5		M40x1.5	40.0	30.0	14.5
CRA-M40-42.5	AD42.5	M40x1.5	40.0	35.0	14.5
CRA-M48-42.5		M48x2.0	48.0	38.0	14.5
CRA-M50-54.5	AD54.5	M50x1.5	50.0	44.0	16.0
CRA-M60-54.5		M60x2.0	60.0	53.0	16.0
CRA-PG7-10.0	AD10.0	PG7	12.5	9.0	10.0
CRA-PG9-13.0	AD13.0	PG9	15.2	11.6	10.0
CRA-PG11-15.8	AD15.8	PG11	18.6	13.5	10.0
CRA-PG13.5-18.5	AD18.5	PG13.5	20.4	16.0	11.0
CRA-PG16-21.2	AD21.2	PG16	22.5	17.5	13.0
CRA-PG21-28.5	AD28.5	PG21	28.3	23.0	13.0
CRA-PG29-34.5	AD34.5	PG29	37.0	30.0	14.5
CRA-PG36-42.5	AD42.5	PG36	47.0	38.0	14.5
CRA-PG48-54.5	AD54.5	PG48	59.3	52.0	16.0

防水型浪管接头MG, PG型

RoHS CE IP68



螺牙规格：公制牙MG，德制牙PG，符合欧盟规范；

产品材质：A.C.F部分采用UL认可之无卤素(Halogen-Free)尼龙PA66(防火等级UL94V-2)制成；(可定制UL认可的V-0防火等级尼龙原料)；B.D部分采用三元乙丙(EPDM)耐候橡胶制成。(可定制耐寒、耐高温橡胶、耐高酸碱、耐化学与抗腐蚀橡胶)；

保护等级：IP68

工作温度：静态-40°C至100°C，或瞬间可耐热至120°C，动态-20°C至80°C，或瞬间可耐热至100°C；

产品特性：本款高性能防水尼龙浪管盒接头能完美地抗水压，是一款即使拉扯波纹管也能完全保持气密的产品。产品广泛地应用于移动式的自动化设备之防水、防油与气密的场合；

颜色种类：黑色、灰色，其它颜色可定做。

防水型浪管接头MG, PG型

RoHS CE IP68

产品型号 Product Model	适配软管 Accommodated Pipes	螺牙规格 Thread	螺纹外径 C1 Outer diameter(mm)	螺纹长度 Thread Length C2 (mm)	包装 Std.Pkg (pcs)
WBJ-M12-10.0	AD10.0	M12x1.5	12	9	50
WBJ-M16-10.0-ST		M16x1.5	16	10	50
WBJ-M16-13.0-ST	AD13.0	M16x1.5	16	10	50
WBJ-M16-13.0		M16x1.5	16	15	50
WBJ-M16-15.8-ST	AD15.8	M16x1.5	16	10	50
WBJ-M16-15.8		M16x1.5	16	15	50
WBJ-M20-15.8-ST		M20x1.5	20	10	50
WBJ-M20-15.8		M20x1.5	20	15	50
WBJ-M22-15.8-ST		M22x1.5	22	10	50
WBJ-M22-15.8		M22x1.5	22	15	50
WBJ-M25-15.8-ST		M25x1.5	25	12	50
WBJ-M16-18.5-ST	AD18.5	M16x1.5	16	10	50
WBJ-M16-18.5		M16x1.5	16	15	50
WBJ-M20-18.5-ST		M20x1.5	20	10	50
WBJ-M20-18.5		M20x1.5	20	15	50
WBJ-M22-18.5-ST		M22x1.5	22	10	50
WBJ-M22-18.5		M22x1.5	15	22	50
WBJ-M20-21.2-ST	AD21.2	M20x1.5	20	10	50
WBJ-M20-21.2		M20x1.5	20	15	50
WBJ-M25-21.2-ST		M25x1.5	25	10	50
WBJ-M25-21.2		M25x1.5	25	15	50
WBJ-M25-25.0-ST	AD25.0	M25x1.5	25	10	50
WBJ-M25-25.0		M25x1.5	25	15	50
WBJ-M25-26.2-ST	AD26.2	M25x 1.5	25	10	50
WBJ-M25-26.2		M25x 1.5	25	15	50
WBJ-M25-28.5-ST	AD28.5	M25x1.5	25	10	50
WBJ-M25-28.5		M25x1.5	25	15	50
WBJ-M32-34.5-ST	AD34.5	M32x1.5	32	10	20
WBJ-M32-34.5		M32x1.5	32	15	20
WBJ-M40-42.5	AD42.5	M40x1.5	40	15	10
WBJ-M50-42.5		M50x1.5	50	15	10
WBJ-M40-42.5	AD42.5	M40x1.5	40	15	10
WBJ-M50-42.5		M50x1.5	50	15	10
WBJ-M50-48	AD48	M50x1.5	50	15	10
WBJ-M50-54.5	AD54.5	M50x1.5	50	22	10
WBJ-M63-54.5		M63x1.5	63	25	10
WBJ-PG7-10.0	AD10.0	PG7	12.5	9	50
WBJ-PG9-10.0		PG9	15.2	9	50
WBJ-PG11-13.0	AD13.0	PG11	18.6	10	50
WBJ-PG13.5-15.8	AD15.8	PG13.5	20.4	10	50
WBJ-PG16-15.8		PG16	22.5	10.8	50
WBJ-PG13.5-18.5	AD18.5	PG13.5	20.4	10	50
WBJ-PG16-18.5		PG16	22.5	10.8	50
WBJ-PG16-21.2	AD21.2	PG16	22.5	13	50
WBJ-PG21-21.2		PG21	28.3	13	50
WBJ-PG21-28.5	AD28.5	PG21	28.3	13	50
WBJ-PG29-34.5	AD34.5	PG29	37	13	20
WBJ-PG36-42.5	AD42.5	PG36	47	13	10
WBJ-PG48-54.5	AD54.5	PG48	59.3	16	10

www.dmlbox.com

电气辅材

HRQS带盖固定座 HWQS不带盖固定座



规格型号		对应软管	A (mm)	B (mm)	C (mm)	E (mm)	螺钉孔径	包装
带盖固定座	不带盖固定座							
HRQS AD10.0	HWQS AD10.0	AD10.0	21.67	26.67	8	20	4.2	50
HRQS AD13.0	HWQS AD13.0B	AD13.0	26	32	5.5	20	4.2	50
HRQS AD15.8	HWQS AD15.8B	AD15.8	26	32	10	20	4.2	50
HRQS AD18.5G	HWQS AD18.5B	AD18.5	32.5	40	12.5	20	4.2	50
HRQS AD21.2G	HWQS AD21.2B	AD21.2	32.5	40	16.6	20	4.2	50
HRQS AD28.5G	HWQS AD28.5B	AD28.5	43.33	43.34	20	20	4.2	20
HRQS AD34.5G	HWQS AD34.5B	AD34.5	43.33	53.34	25.5	20	4.2	20
HRQS AD42.5G	HWQS AD42.5B	AD42.5	65	80	30	20	4.2	10
HRQS AD54.5G	HWQS AD54.5B	AD54.5	65	80	38	20	4.2	5

波纹软管



产品材质: PA、PA阻燃、PP、PP阻燃、PE、P E 阻燃

工作温度: -40℃至125℃短时可达140℃

产品结构: 内部和外表均为波浪型。

产品特性: 柔韧性好、抗扭曲、弯曲性能好。可以承受较重的负载;耐酸、润滑油、冷却液等;表面有光泽、耐摩擦。

承载能力: 可以承受脚踩的重压,不断裂、不变形,可以迅速恢复,并且本身无任何损伤。

颜色种类: 黑色,其它颜色可定做(根据需要可开口)。

应用领域: 机械制造、电气绝缘保护、照明设备、汽车制造、航空设备、地铁、高铁、自动化控制等行业。

使用方法: 将电线电缆插入管内,再配上软管接头对应的型号使用即可。

阻燃等级	HP V2 HHP V0	材质	PA PE PP	规格
------	-----------------	----	----------------	----

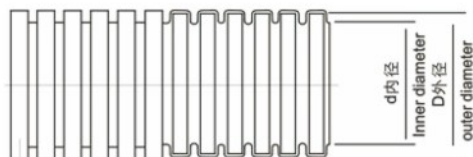

软管规格(AD) Specification	内径x外径(mm) Inner diameter x Outer diameter	弯曲半径(mm) Curved radius	包装 Std.Pkg (pcs)
AD10.0	6.5x10.0	16	100
AD11.6	8.0x11.6	16	100
AD13.0	10.0x13.0	20	100
AD15.8	12.0x15.8	30	100
AD18.5	14.3x18.5	40	100
AD21.2	17.0x21.2	45	100
AD25.0	20.0x25.0	45	50
AD28.5	23.0x28.5	50	50
AD34.5	29.0x34.5	70	50
AD42.5	36.0x42.5	60	50
AD54.5	48.0x54.5	90	25



颜色：线槽常用线槽颜色为灰色，其它颜色可以根据客户需要调配，但得一定的批量才行。

长度：此类线槽的常规长度是2米/条，如需特殊长度，则得后续再进行裁切加工，这中间有两个问题出现：产品切后两端可能出现尖角毛刺，因切具切口可能就在齿上，一个齿被切掉一半后就没有力度了；由于是刀具有一定厚度，因此，切后长度可能有5MM的误差；因后续切都是人工处理，会需要一定的加工时间，需求的量不同，需时也不一样。

机柜机箱配电线槽特点

- 1.用料纯正，抗折压，结合面平滑，伪劣线槽材料中加了许多石灰石，不抗折，齿易断；
- 2.阻燃性好、离火即灭、氧指数大于40，在遇火的情况下，能阻止火势的蔓延，保护线路；
- 3.绝缘性能强，能承受2500V电压，避免漏电触电的危险；
- 4.外形整洁美观，施工检修方便，防火、防腐效果能得到可靠的保证。

适用范围

高低压控制机柜机箱、大型机械设备、室内架空线缆布设，一般工业厂房有酸碱腐蚀及防火区域内的电源线路布设及保护。

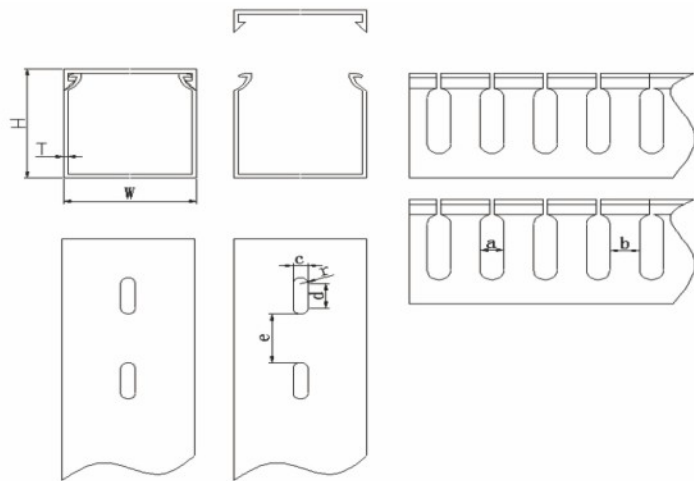

□ □ □

型号
PXC

□ □ □ □

规格
高X宽

□ □

齿形
常规01
封口02
细齿03
定制04

产规格 (高*宽)	常规	封口	细齿	产规格 (高*宽)	常规	封口	细齿
2525	5*7	/	/	6060	8*10	10*10	4*6
3020	6*7	/	/	6080	8*10	10*10	4*6
3025	6*7	/	/	60100	8*10	10*10	4*6
3030	6*7	/	/	6525	8*10	10*10	4*6
3035	6*7	/	/	6533	8*10	10*10	4*6
3333	6*7	/	/	6545	8*10	10*10	4*6
3040	6*7	/	/	6565	8*10	10*10	4*6
3525	6*7	/	/	7525	8*10	/	/
3535	6*7	/	/	7550	8*10	/	/
4025	6*8	10*10	4*6	7575	8*10	/	/
4040	6*8	10*10	4*6	8025	10*12	10*10	4*6
4060	6*8	10*10	4*6	5035	10*12	10*12	4*6
4525	8*10	10*10	4*6	8040	10*12	10*12	4*6
4533	8*10	10*10	4*6	8045	10*12	10*12	4*6
4545	8*10	10*10	4*6	8050	10*12	10*12	4*6
4565	8*10	10*10	/	8055	10*12	10*12	4*6
5020	6*8	/	4*6	8060	10*12	10*12	4*6
5025	6*8	10*10	4*6	8080	10*12	10*12	4*6
5030	6*8	10*10	4*6	80100	10*12	10*12	4*6
5035	6*8	10*10	4*6	80120	10*12	10*10	4*6
5040	6*8	10*10	4*6	80140	10*12	10*10	4*6
5045	6*8	10*10	4*6	9040	8*10	/	/
5050	6*8	10*10	4*6	9045	8*10	/	/
5055	6*8	10*10	4*6	9060	8*10	/	/
5060	6*8	10*10	4*6	10033	10*12	10*12	4*6
5080	8*10	10*10	4*6	10040	10*12	10*12	4*6
50100	8*10	10*10	4*6	10050	10*12	10*12	4*6
6025	8*10	10*10	4*6	10060	10*12	10*12	4*6
6030	8*10	10*10	4*6	10070	10*12	10*12	4*6
6040	8*10	10*10	4*6	10080	10*12	10*12	4*6
6045	8*10	10*10	4*6	100100	10*12	10*12	4*6
6050	8*10	10*10	4*6	130100	8*10	/	/
/	/	/	/	150100	/	10*10	/

宽度25-70mm为单排孔，孔距为50mm；宽度100mm为三排孔，孔距为50mm；宽度为80mm，为三孔二排，孔距为100mm

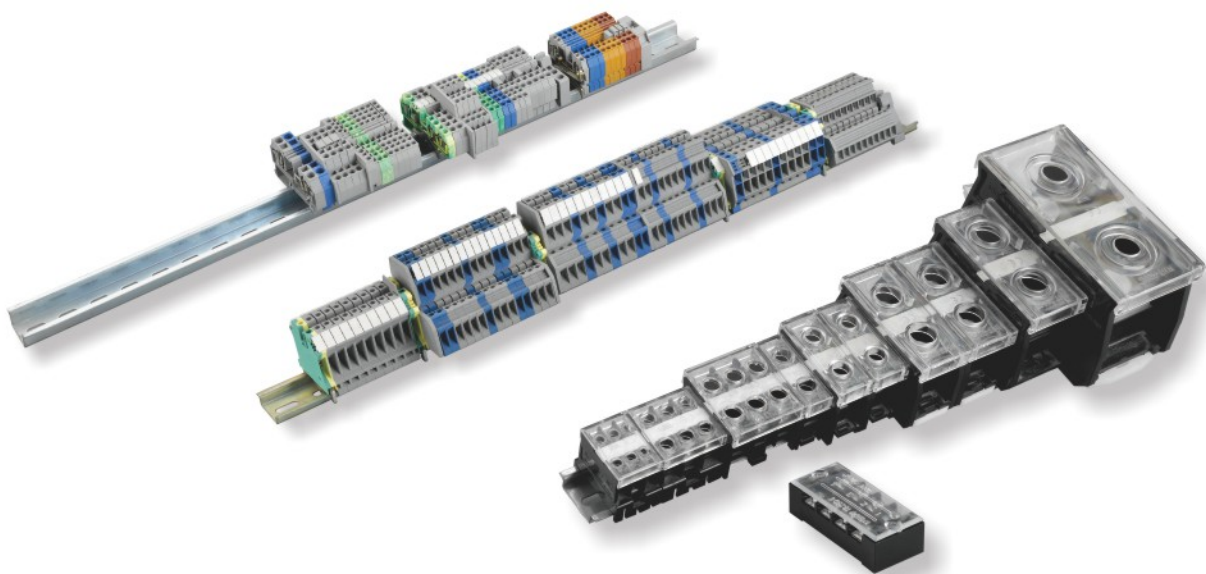

型号	电流/电压	导线mm ²	尺寸 (厚/宽/高)	中心联接件	挡板	固定件	导轨
UK 1.5N RUK 1.5N	17.5/500	1.5	4.2/42.5/42	FBI 10-4	D-RUK 2.5	E/UK	TS 35/7.5
UK 2.5N RUK 2.5B	32/690	2.5	6.2/42.5/42	FBI 10-6	D-RUK 2.5	E/UK	TS 35/7.5
UK 3N RUK 3N	32/800	3	5.2/42.5/47	FBI 10-5	D-RUK 3/16	E/UK	TS 35/7.5
UK 5N RUK 5N	41/800	4	6.2/42.5/47	FBI 10-6	D-RUK 3/16	E/UK	TS 35/7.5
UK 6N RUK 6N	57/800	6	8.2/42.5/47	FBI 10-8	D-RUK 3/16	E/UK	TS 35/7.5
UK 10N RUK 10N	76/800	10	10.2/42.5/47	FBI 10-10	D-RUK 3/16	E/UK	TS 35/7.5
UK 16N RUK 16N	101/800	16	12.2/42.5/47	FBI 10-12	D-RUK 3/16	E/UK	TS 35/7.5

检修箱

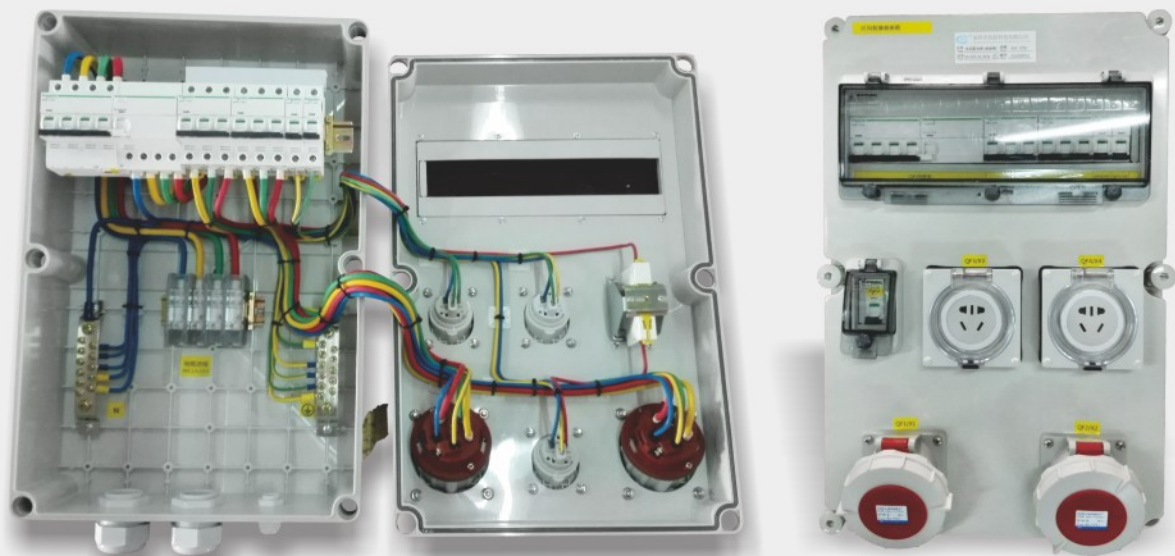

照明箱



浩跃工程项目部分产品，如需了解更多产品，请咨询我司销售人员提供另外产品目录



四川德米勒电气有限公司

地址：成都市龙泉驿区经开区车城西二
路288号派瑞国际3栋1528号

电话：028-84684949

邮箱：dmldq@163.com

网址：www.dmlbox.com

