

Product Specification
RoHS-6 Compliant
10Gb/s 850nm Multimode Datacom SFP+ Transceiver

PRODUCT FEATURE

- Hot-pluggable SFP+ footprint
- Supports 9.95 to 10.3 Gb/s bitrates*
- Power dissipation < 1W
- RoHS-6 compliant (lead-free)
- Commercial temperature rang 0°C to 70°C
- Single 3.3V power supply
- Maximum link length of 300m on 2000 MHZ-km MMF
- Uncooled 850nm VCSEL laser
- Receiver limiting electrical interface
- Duplex LC connector
- Built-in digital diagnostic functions

**APPLICATIONS**

- 10GBASE-SR/SW 10G Ethernet

ZYTOM's SFP+10GB-SR 10Gb/s SFP+ transceivers are designed for use in 10-Gigabit Ethernet links over multimode fiber. They are compliant with SFF-8431¹, SFF-8432² and IEEE 802.3ae 10GBASE-SR/SW³. Digital diagnostics functions are available via a 2-wire serial interface, as specified in SFF-8472⁴.

PRODUCT SELECTION

I. Pin Descriptions

| Pin | Symbol | Name/Description | Ref. |
|-----|--------------------|--|------|
| 1 | V _{EET} | Transmitter Ground (Common with Receiver Ground) | 1 |
| 2 | T _{FAULT} | Transmitter Fault. | 2 |
| 3 | T _{DIS} | Transmitter Disable. Laser output disabled on high or open. | 3 |
| 4 | SDA | 2-wire Serial Interface Data Line | 4 |
| 5 | SCL | 2-wire Serial Interface Clock Line | 4 |
| 6 | MOD_ABS | Module Absent. Grounded within the module | 4 |
| 7 | RS0 | No connection required | |
| 8 | RX_LOS | Loss of Signal indication. Logic 0 indicates normal operation. | 5 |
| 9 | RS1 | No connection required | |
| 10 | V _{EER} | Receiver Ground (Common with Transmitter Ground) | 1 |
| 11 | V _{EER} | Receiver Ground (Common with Transmitter Ground) | 1 |
| 12 | RD- | Receiver Inverted DATA out. AC Coupled | |
| 13 | RD+ | Receiver Non-inverted DATA out. AC Coupled | |
| 14 | V _{EER} | Receiver Ground (Common with Transmitter Ground) | 1 |
| 15 | V _{CCR} | Receiver Power Supply | |
| 16 | V _{CCT} | Transmitter Power Supply | |
| 17 | V _{EET} | Transmitter Ground (Common with Receiver Ground) | 1 |
| 18 | TD+ | Transmitter Non-Inverted DATA in. AC Coupled. | |
| 19 | TD- | Transmitter Inverted DATA in. AC Coupled. | |
| 20 | V _{EET} | Transmitter Ground (Common with Receiver Ground) | 1 |

Notes:

- Circuit ground is internally isolated from chassis ground.
- T_{fault} is an open collector/drain output, which should be pulled up with a 4.7k – 10k Ohms resistor on the host board if intended for use. Pull up voltage should be between 2.0V to V_{cc} + 0.3V. A high output indicates a transmitter fault caused by either the TX bias current or the TX output power exceeding the preset alarm thresholds. A low output indicates normal operation. In the low state, the output is pulled to <0.8V.
- Laser output disabled on T_{DIS} >2.0V or open, enabled on T_{DIS} <0.8V.
- Should be pulled up with 4.7kΩ – 10kΩ on host board to a voltage between 2.0V and 3.6V.
MOD_ABS pulls line low to indicate module is plugged in.
- LOS is open collector output. Should be pulled up with 4.7kΩ – 10kΩ on host board to a voltage between 2.0V and 3.6V. Logic 0 indicates normal operation; logic 1 indicates loss of signal.

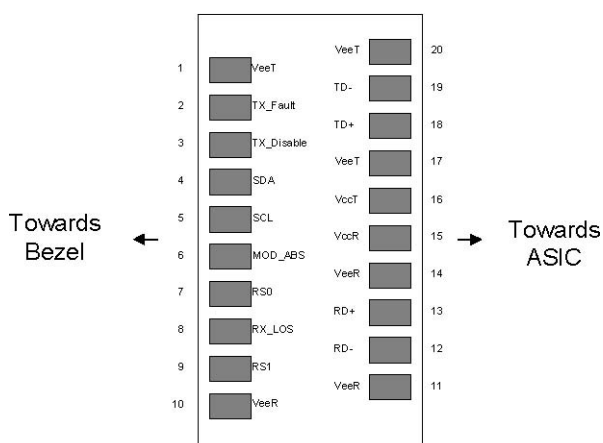

Figure 1. Diagram of Host Board Connector Block Pin Numbers and Names.

II. Absolute Maximum Ratings

Exceeding the limits below may damage the transceiver module permanently.

| Parameter | Symbol | Min | Typ | Max | Unit | Ref. |
|----------------------------|--------|------|-----|-----|------|------|
| Maximum Supply Voltage | Vcc | -0.5 | | 4.0 | V | |
| Storage Temperature | Ts | -40 | | 85 | ° C | |
| Case Operating Temperature | TA | 0 | | 70 | ° C | |
| Relative Humidity | RH | 0 | | 85 | % | 1 |

Notes:

I. Non-condensing.

III. Electrical Characteristics (TOP = 0 to 70 °C, VCC = 3.14 to 3.46 Volts)

| Parameter | Symbol | Min | Typ | Max | Unit | Ref. |
|----------------------------------|------------|------|-----|----------|------|------|
| Supply Voltage | Vcc | 3.14 | | 3.46 | V | |
| Supply Current | Icc | | | 250 | mA | |
| Transmitter | | | | | | |
| Input differential impedance | Rin | | 100 | | Ω | 1 |
| Differential data input swing | Vin,pp | 180 | | 700 | mV | |
| Transmit Disable Voltage | VD | 2 | | Vcc | V | |
| Transmit Enable Voltage | VEN | Vee | | Vee+ 0.8 | V | |
| Receiver | | | | | | |
| Differential data output swing | Vout,pp | 300 | | 850 | mV | 2 |
| Data output rise time, fall time | tr | 28 | | | ps | 3 |
| LOS Fault | VLOS fault | 2 | | VcCHOST | V | 4 |
| LOS Normal | VLOS norm | Vee | | Vee+0.8 | V | 4 |

| | | | | |
|------------------------------|-----------|----------------------|------|---|
| Power Supply Noise Tolerance | VccT/VccR | Per SFF-8431 Rev 2.1 | mVpp | 5 |
|------------------------------|-----------|----------------------|------|---|

Notes:

1. Connected directly to TX data input pins. AC coupling from pins into laser driver IC.
2. Into 100 Ω differential termination.
3. 20 – 80 % . Measured with Module Compliance Test Board and OMA test pattern. Use of four 1's and four 0's in sequence in the PRBS⁹ is an acceptable alternative. SFF-8431 Rev 2.1
4. LOS is an open collector output. Should be pulled up with 4.7k Ω – 10k Ω on the host board. Normal operation is logic 0; loss of signal is logic 1. Maximum pull-up voltage is 5.5V.
5. Testing methodology per SFF-8431. Rev 2.1

IV. Optical Characteristics (TOP = 0 to 70 °C, VCC = 3.14 to 3.46 Volts)

| Parameter | Symbol | Min | Typ | Max | Unit | Ref. | |
|--|----------------------|-------------------------------|------|-------|-------|------|--|
| Transmitter | | | | | | | |
| Optical Modulation Amplitude (OMA) | P _{OMA} | | -1.5 | | dBm | 1 | |
| Average Launch Power | P _{AVE} | -5 | | -1 | dBm | 2 | |
| Optical Wavelength | λ | 840 | 850 | 860 | nm | 1 | |
| RMS Spectral Width | Δ λ _{rms} | | | 0.45 | dB | 1 | |
| Optical Extinction Ratio | ER | 3.0 | 5.5 | | dB | | |
| Transmitter and Dispersion Penalty | TDP | | | 3.9 | dB | | |
| Average Launch power of OFF transmitter | P _{OFF} | | | -30 | dBm | | |
| Tx Jitter | T _{Xj} | Per IEEE 802.3ae requirements | | | | | |
| Encircled Flux | <4.5μm | | | 30 | % | 3 | |
| | <19μm | 86 | | | | | |
| Relative Intensity Noise | RIN _{12OMA} | | | -128 | dB/Hz | | |
| Receiver | | | | | | | |
| Receiver Sensitivity (OMA) @ 10.3Gb/s | R _{SENS1} | | | -11.1 | dBm | 4 | |
| Stressed Receiver Sensitivity (OMA) @ 10.3Gb/s | R _{SENS2} | | | -7.5 | dBm | 5 | |
| Maximum Input Power | P _{MAX} | +0.5 | | | dBm | | |
| Wavelength Range | λ _C | 840 | | 860 | nm | | |
| Receiver Reflectance | R _{rx} | | | -12 | dB | | |
| LOS De-Assert | LOS _D | | | -14 | dBm | | |
| LOS Assert | LOS _A | -30 | -23 | | dBm | | |
| LOS Hysteresis | | 0.5 | | | dB | | |

Notes:

1. Per Tradeoff Table 52.8, IEEE 802.3ae 2005
2. Average Power figures are informative only, per IEEE802.3ae.
3. Measured into Type A1a (50/125 μm multimode) fiber per ANSI/TIA/EIA-455-203-2.
4. Measured with worst ER; BER<10⁻¹² ; 2³¹ - 1 PRBS.
5. Per IEEE 802.3ae.

V. General Specifications

| Parameter | | Symbol | Min | Typ | Max | Units | Ref. |
|------------------------------------|---------------------|--------|------|------|-------------------|-------|------|
| Bit Rate | | BR | 9.95 | 10.3 | | Gb/s | 1 |
| Bit Error Ratio | | BER | | | 10 ⁻¹² | | 2 |
| Maximum Supported Distances | | | | | | | |
| Fiber Type | 850nm OFL Bandwidth | | | | | | |
| 62.5μm | 160 MHz-km | Lmax | | | 26 | m | |
| | OM1 200 MHz-km | | | | 33 | | |

| | | | | | | | |
|------|-----------------|------|--|--|-----|---|--|
| 50μm | 400 MHz-km | Lmax | | | 66 | m | |
| | OM2 500 MHz-km | | | | 82 | | |
| | OM3 2000 MHz-km | | | | 300 | | |

Notes:

1. 10GBASE-SR/SW. Contact Optone's for higher data-rate support.
2. Tested with a 2³¹ - 1 PRBS

VI. Environmental Specifications

ZYTOM's 850nm SFP transceivers have a commercial operating temperature range from 0°C to +70°C case temperature.

| Parameter | Symbol | Min | Typ | Max | Units | Ref. |
|----------------------------|------------------|-----|-----|-----|-------|------|
| Case Operating Temperature | T _{op} | 0 | | 70 | °C | |
| Storage Temperature | T _{sto} | -40 | | 85 | °C | |

VII. Regulatory Compliance

ZYTOM's transceivers are Class 1 Laser Products and comply with US FDA regulations. These products are certified by TÜV and CSA to meet the Class 1 eye safety requirements of EN (IEC) 60825 and the electrical safety requirements of EN (IEC) 60950. Copies of certificates are available at OPTONE's Corporation upon request.

VIII. Digital Diagnostic Functions

ZYTOM's SFP+10GB-SR SFP+ transceivers support the 2-wire serial communication protocol as defined in the SFF-8472. It is very closely related to the E²PROM defined in the GBIC standard, with the same electrical specifications.

The standard SFP+ serial ID provides access to identification information that describes the transceiver's capabilities, standard interfaces, manufacturer, and other information.

Additionally, ZYTOM's SFP+ transceivers provide an enhanced digital diagnostic monitoring interface, which allows real-time access to device operating parameters such as transceiver temperature, laser bias current, transmitted optical power, received optical power and transceiver supply voltage. It also defines a sophisticated system of alarm and warning flags, which alerts end-users when particular operating parameters are outside of a factory set normal range.

SFF-8472 defines a 256-byte memory map in E²PROM that is accessible over a 2-wire serial interface at the 8 bit address 1010000X (A0h). The digital diagnostic monitoring interface makes use of the 8 bit address 1010001X (A2h), so the originally defined serial ID memory map remains unchanged. The interface is identical to, and is thus fully backward compatible with both the GBIC Specification and the SFP Multi Source Agreement. The complete interface is described in ZYTOM's Application Note AN2030: "Digital Diagnostics Monitoring Interface for SFP Optical Transceivers".

The operating and diagnostics information is monitored and reported by a Digital Diagnostics Transceiver Controller (DDTC) inside the transceiver, which is accessed through a 2-wire serial interface. When the serial protocol is activated, the serial clock signal (SCL, Mod Def 1) is generated by the host. The positive edge clocks data into the SFP transceiver into those segments of the E²PROM that are not write-protected. The negative edge clocks data from the SFP transceiver. The serial data signal (SDA, Mod Def 2) is bi-directional for serial data transfer. The host uses SDA in conjunction with SCL to mark the start and end of serial protocol activation. The memories are organized as a series of 8-bit data words that can be addressed individually or sequentially.

For more information, please see the SFF-8472 documentation and ZYTOM's Application Note AN-2030.

IX. Digital Diagnostic Specifications

SFP+10GB-SR transceivers can be used in host systems that require either internally or externally calibrated digital diagnostics.

| Parameter | Symbol | Min | Typ | Max | Units | Ref. |
|--|---------------|------|-----|------|-------|------|
| Accuracy | | | | | | |
| Internally measured transceiver temperature | DDTemperature | -3 | | 3 | °C | |
| Internally measured transceiver supply voltage | DDVoltage | -100 | | 100 | mV | |
| Measured TX bias current | DDBias | -10 | | 10 | % | 1 |
| Measured TX output power | DDTx-Power | -2 | | 2 | dB | |
| Measured RX received average optical power | DDRx-Power | -2 | | 2 | dB | |
| Dynamic Range for Rated Accuracy | | | | | | |
| Internally measured transceiver temperature | DDTemperature | 0 | | 70 | °C | |
| Internally measured transceiver supply voltage | DDVoltage | 3.14 | | 3.46 | V | |
| Measured TX bias current | DDBias | 0 | | 20 | mA | |
| Measured TX output power | DDTx-Power | -9 | | -2.5 | dBm | |
| Measured RX received average optical power | DDRx-Power | -20 | | 0 | dBm | |
| Max Reporting Range | | | | | | |
| Internally measured transceiver temperature | DDTemperature | -40 | | 125 | °C | |
| Internally measured transceiver supply voltage | DDVoltage | 2.8 | | 4.0 | V | |
| Measured TX bias current | DDBias | 0 | | 20 | mA | |
| Measured TX output power | DDTx-Power | -10 | | -3 | dBm | |
| Measured RX received average optical power | DDRx-Power | -22 | | 0 | dBm | |

Notes:

1. Accuracy of Measured Tx Bias Current is 10% of the actual Bias Current from the laser driver to the laser.

X. Mechanical Specifications

ZYTOM’s SFP+10GB-SR SFP+ transceivers are compatible with the SFF-8432 specification for improved pluggable form factor, and shown here for reference purposes only. Bail color is beige.

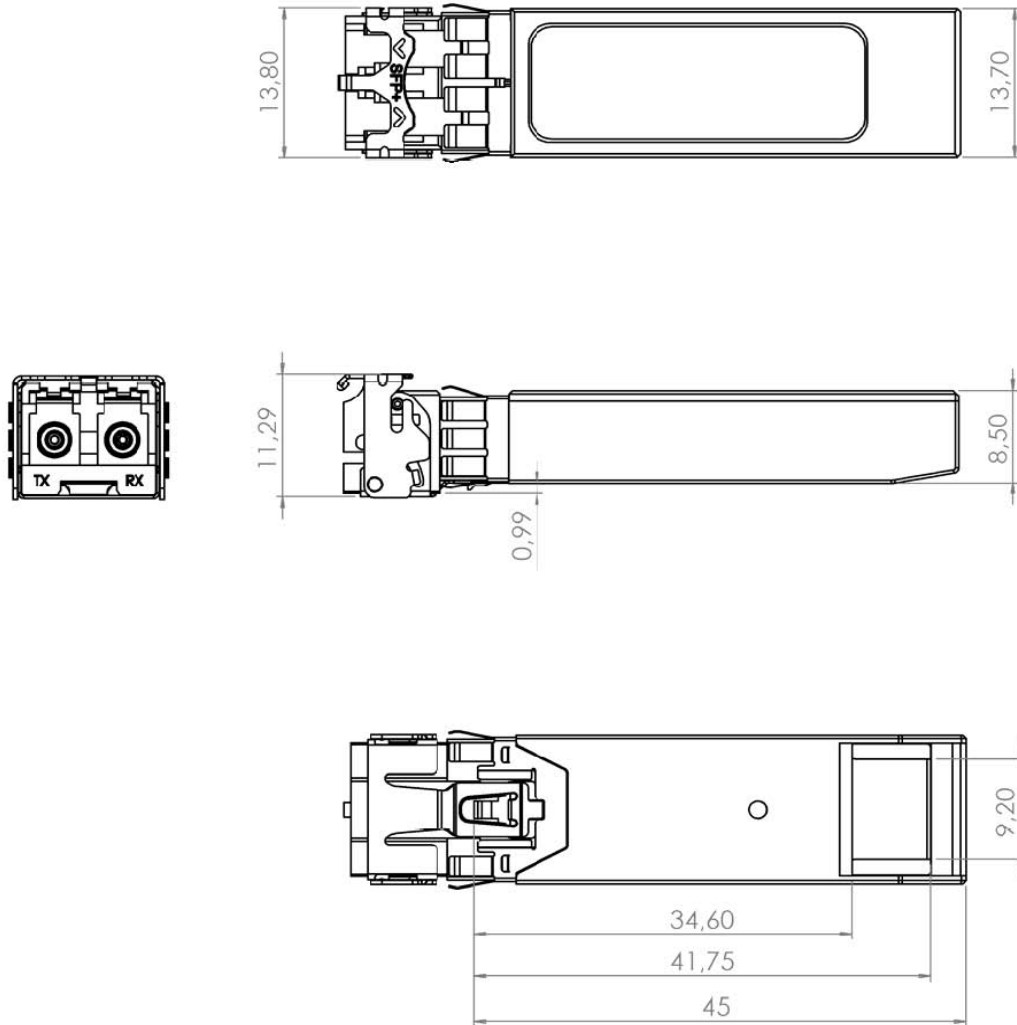

Figure 3. SFP+10GB-SR Mechanical Dimensions.

XI. PCB Layout and Bezel Recommendations

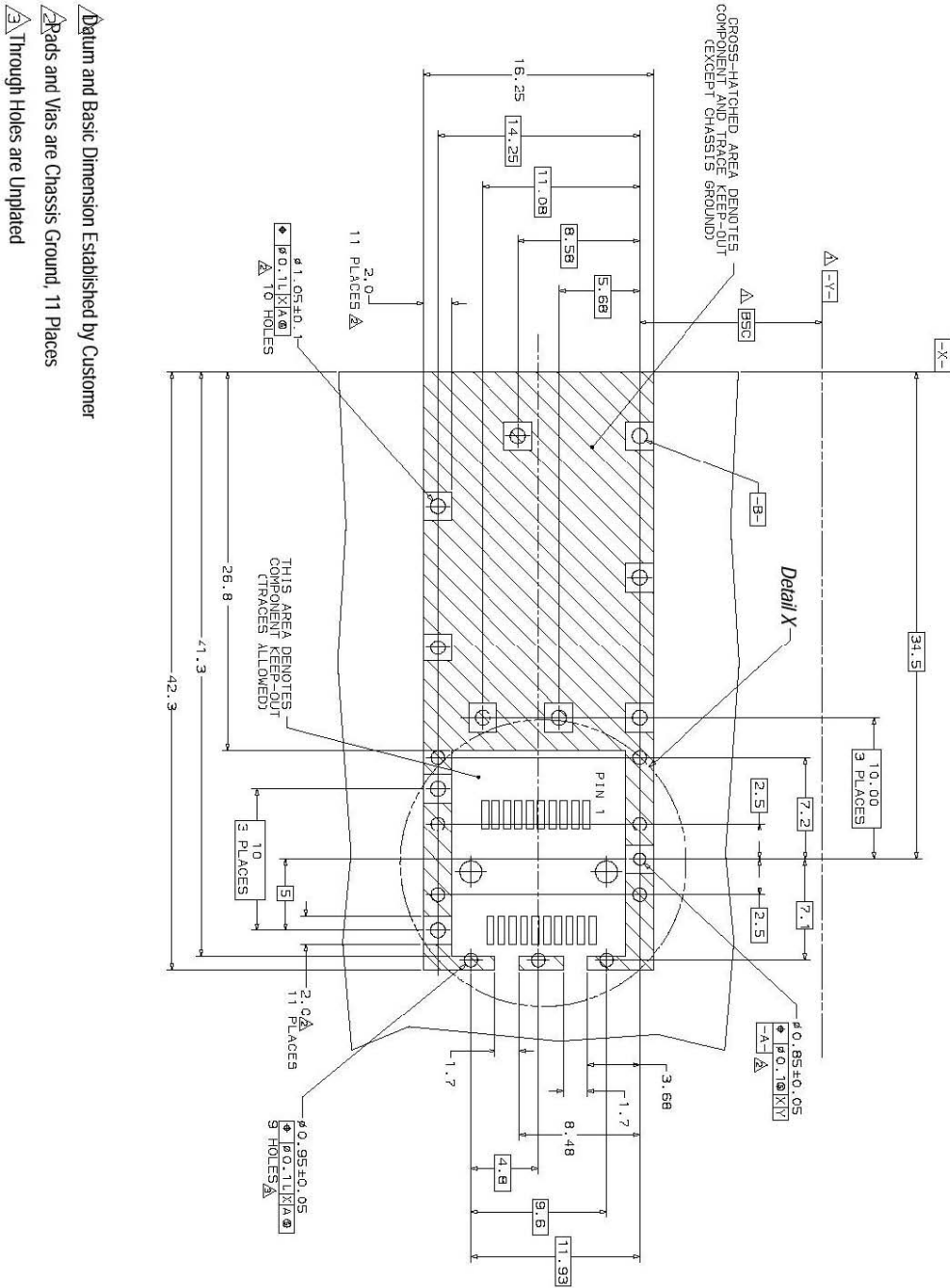
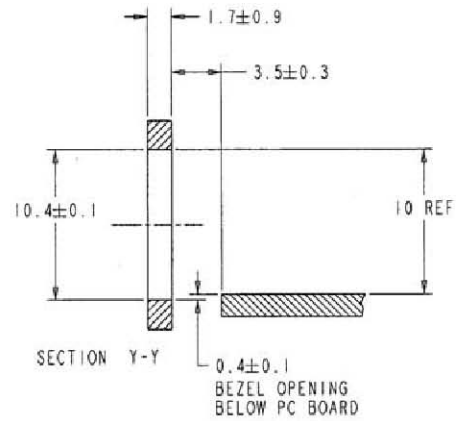
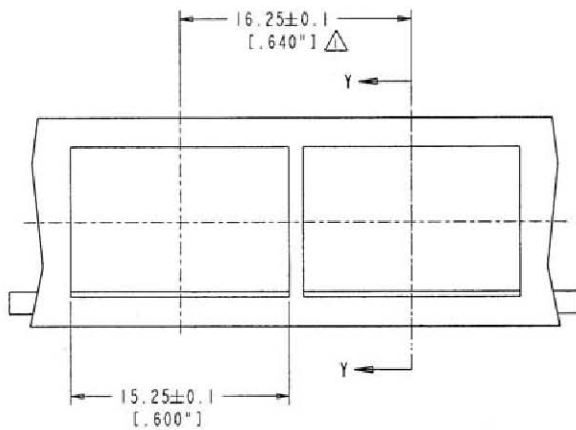
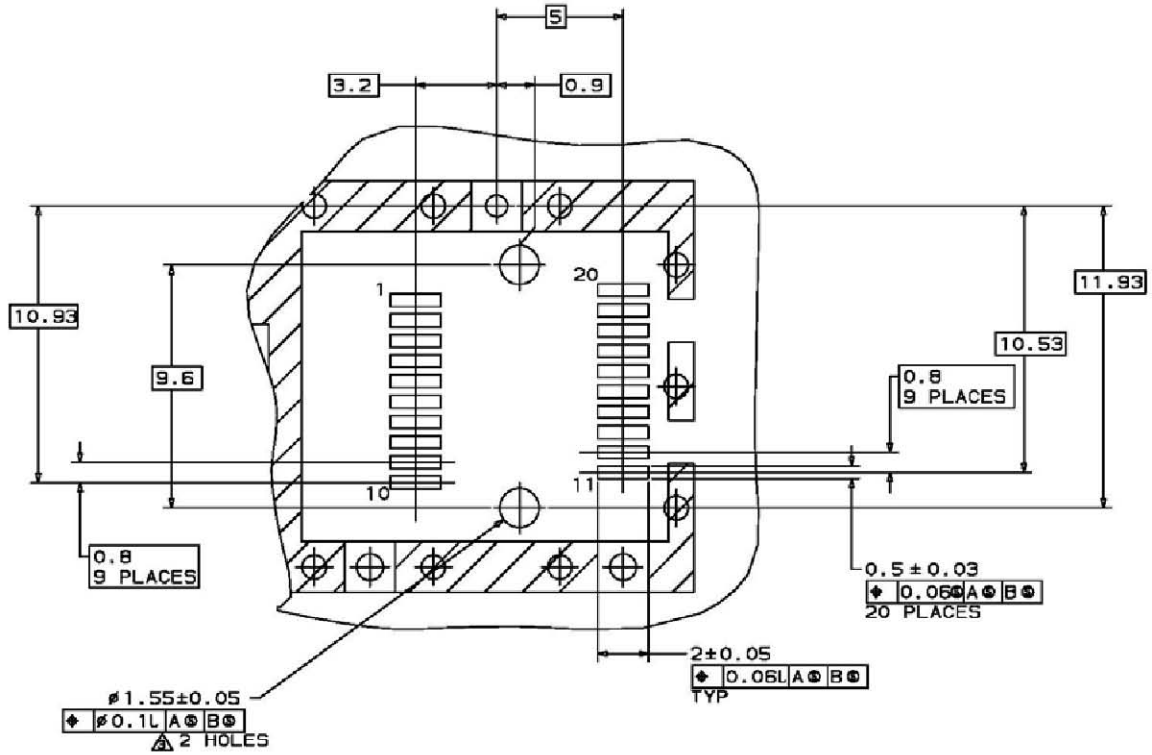

Figure 4. Figure 5. XII. Host - Transceiver Interface Block Diagram



NOTES:

△ MINIMUM PITCH ILLUSTRATED. ENGLISH DIMENSIONS ARE FOR REFERENCE ONLY

2. NOT RECOMMENDED FOR PCI EXPANSION CARD APPLICATIONS

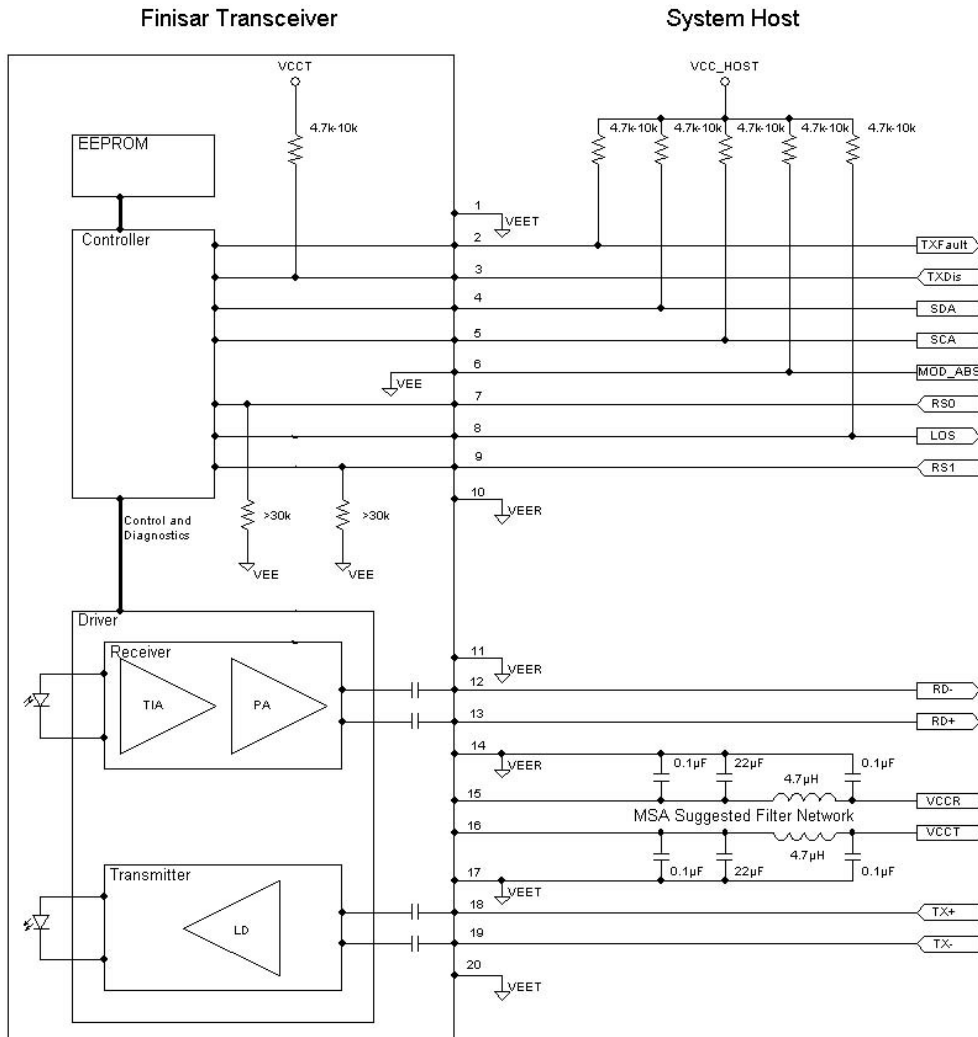

Figure 6-Host-Module Interface

Ordering information

| Part Number | Product Description |
|--------------|---|
| SFP+-10GB-SR | 10Gbps, 850nm SFP+SR 300m, -5oC ~ +70oC |