

## SDHmini-Ex

**The Model SDHmini-Ex portable hygrometer sets new industry standards for dewpoint measurement.**

An intrinsically safe portable dewpoint hygrometer which offers quick and reliable spot-check measurements of dewpoint and trace moisture content for industrial applications. This robust and lightweight instrument features an intuitive menu structure and advanced features which will enable the user to perform measurements in the toughest of environments, quicker and easier than ever before.

Certified intrinsically safe to ATEX, IECEx and UL standards, the SDHmini-Ex is the perfect tool for reliable measurements in hazardous areas.

The robust housing not only contains the moisture sensor, desiccant chamber and gas sample ports but also incorporates the signal conditioning circuitry, memory management and a full colour graphics LCD. The on-board rechargeable lithium-ion battery provides over 150 hours of continuous operation.



The unit operates with the following ten language options: English, German, French, Spanish, Portuguese, Russian, Italian, Chinese, Japanese and Korean.

Powerful microelectronics provide automatic calibration with real time data logging graphical formats for the capture and display of up to 300,000 data points with USB and Bluetooth interfaces for PC communication and printing.



### Features

- Certified intrinsically safe for use in hazardous areas to ATEX, IECEx and UL standards
- Automatic Calibration (AutoCal)
- Desiccant dry down assembly for high speed measurements
- User selectable engineering units - °C, °F, ppm(v), ppm(w), g/m<sup>3</sup>, lbs/MMscf
- Accuracy of  $\pm 2$  °C ( $\pm 3.6$  °F)
- Various measurement ranges available from -100 °C to +20 °C dewpoint
- Full colour graphics LCD display, with secondary display
- 10 language options
- Rechargeable battery - over 150 hours of continuous operation on full charge
- Advanced data logging and download to PC
- USB charging/connection to PC interface
- Bluetooth connection/printing
- Robust and durable enclosure, designed for use in the toughest environments
- Truly portable and lightweight: less than 1.75 kg (3.8 lbs)
- Calibration Certificate traceable to National & International Humidity Standards



MOISTURE METERS

## Desiccant Dry-Down Technology

## General Assembly Diagram

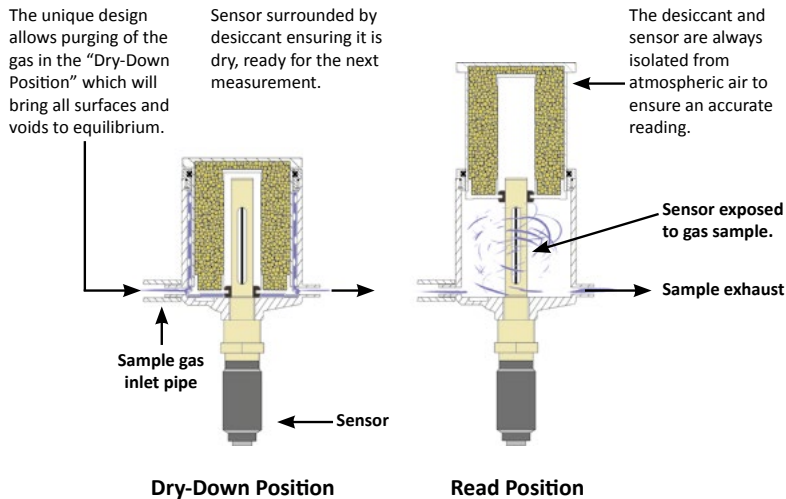

Keeping the sensor dry between tests ensures that the SDHmini-Ex is ready to carry out rapid spot checks. The unique design of the desiccant head achieves this by surrounding the sensor with desiccant, keeping the sensor dry. The head is then lifted for sampling, exposing the sensor to the sample gas.

Between tests, the sensor is not allowed to come into contact with ambient air. The chamber is designed so that the void space and chamber wall surfaces are purged with sample gas before exposure of the sensor, giving faster, more accurate and reliable results.

## Automatic Calibration

The most important and unique feature of the SHAW system is the **automatic calibration** facility. Each SHAW sensor is precisely manufactured to saturate with water vapour at its design maximum. Hence, when the sensor is exposed to moisture above its maximum operating range, it will rapidly come into equilibrium and cease to respond to any further increase in moisture. This forms the basis of automatic calibration.

The SHAW sensor can be checked by simply exposing it to any atmosphere which is wetter than the operating range of the sensor (usually room air is sufficient) by raising the desiccant chamber and performing the automatic calibration feature on the instrument. The sensor is now set up with the instrument and ready for use.

Automatic calibration can be carried out in-situ and without the need for any special equipment or skilled personnel. The net result is reduced downtime, minimal calibration costs and immediate verification of the system.

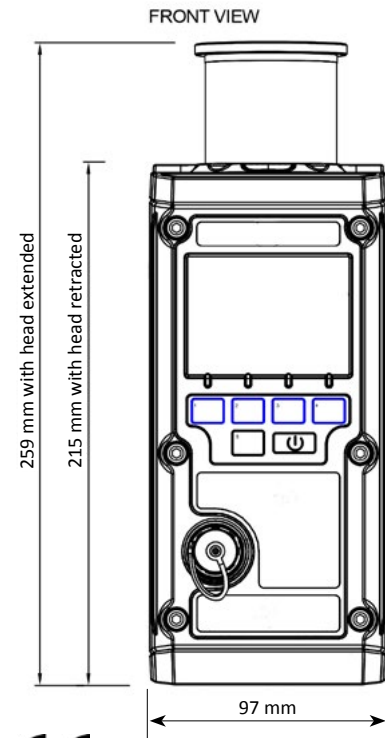

SIDE VIEW

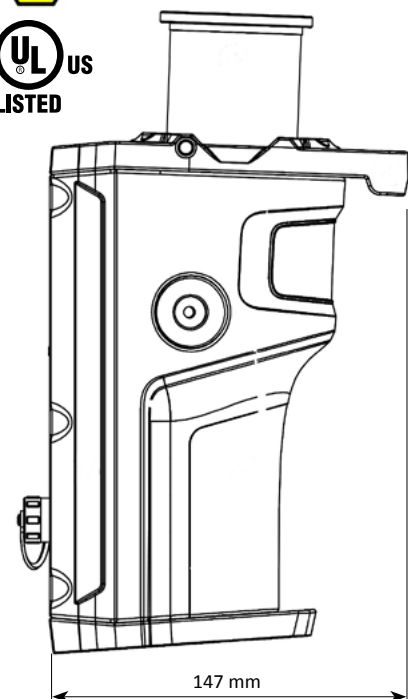



## MOISTURE METERS

### Specifications

#### DEWPOINT SENSOR

- **Sensing Element**  
SHAW Ultra High Capacitance Aluminium Oxide Sensor
- **Ranges**  
Dewpoint = 0.1 °C/0.1 °F resolution  
P (Purple): -100 to 0 °C dewpoint, 0-6,000 ppm(v)  
S (Silver): -100 to -20 °C dewpoint, 0-1,000 ppm(v)  
G (Grey): -80 to 0 °C dewpoint, 0-6,000 ppm(v)  
R (Red): -80 to -20 °C dewpoint, 0-1,000 ppm(v)  
B (Blue): -80 to +20 °C dewpoint, 0-23,000 ppm(v)
- **Intrinsic Safety Certification**  
**ATEX:**  
II 1 G Ex ia IIC T4 Ga  
II 1 D Ex ia IIIB T60°C T5080°C Da  
(-20°C ≤ Ta ≤ +50°C)  
**IECEX:**  
Ex ia IIC T4 Ga  
Ex ia IIIB T60°C T5080°C Da  
(-20°C ≤ Ta ≤ +50°C)  
**UL:**  
Class I Div 1 Groups A, B, C and D T4
- **AutoCal**  
Field calibration/electronic span check facility. Performed by user following simple menu driven instructions.
- **Accuracy**  
± 2 °C (± 3.6 °F) dewpoint  
NPL traceable -90 °C to +20 °C (-130 °F to +68 °F)
- **Sensor Calibration**  
Supplied with Certificate of Calibration traceable to National and International Standards.
- **Pressure Correction**  
Integral calculator to display pressure dewpoints. Gauge pressure can be entered in kPa, kg/cm<sup>2</sup>, bar or psi.

- **Temperature Coefficient**  
Temperature compensated for operating range.
- **Repeatability**  
Better than ±0.3 °C dewpoint
- **Sample Flow Rate**  
Flow independent but ideally 2 to 5 litres per minute. Max: 10 litres/min
- **Response Times**  
Wet to dry: -10 °C to -60 °C - less than 120 seconds  
Dry to wet: -100 °C to -20 °C - less than 20 seconds
- **Calibration Warranty**  
12 months from date of dispatch

#### MECHANICAL

- **Dimensions and Weight**  
Overall dimensions: 97 mm (w) x 147 mm (d) x 211 mm (h (259 mm with head extended)) (3<sup>13</sup>/<sub>16</sub> x 5<sup>25</sup>/<sub>32</sub> x 8<sup>5</sup>/<sub>16</sub> (10<sup>19</sup>/<sub>64</sub>) inches)  
1.75 kg (3.8 lbs)
- **Operating Pressure**  
Maximum 0.3 bar/4 psi
- **Operating Humidity (External)**  
Maximum - 95% RH non-condensing
- **Operating Temperature**  
-20 °C to +50 °C (-4 °F to +122 °F)
- **Storage Temperature**  
-30 °C to +70 °C (-22 °F to +158 °F)
- **Sensor Protection**  
316 sintered stainless steel filter - 50 micron
- **Weatherproof Classification**  
IP66/NEMA 4X
- **Mechanical Warranty**  
24 months in case of faulty workmanship and defective parts

#### ELECTRICAL

- **Electromagnetic Compatibility (EMC)**  
EMC Directive 89/336/EEC, amended 95/31/EEC
- **Display**  
Full colour graphics LCD, 320 x 240 (24 bits) resolution
- **Power Supply**  
Rechargeable Li-ion battery. Battery charger included.
- **Battery Life**  
In excess of 150 hours of use between charges
- **Time to Full Charge**  
12 hours
- **Resolution**  
0.1 °C, 0.1 °F dewpoint or 0.1 ppm(v)
- **Repeatability**  
Better than ±0.2 °C dewpoint

#### SHAW SDHmini USER TOOL SOFTWARE

- **Data Logging**  
300,000 readings. Date and time stamped data, stored in chosen units of measurement, for download to PC.
- **Data Location**  
20 separate Location IDs can be entered (alpha-numerical) by user for data collection at pre-programmed locations.
- **Sampling Rates**  
User selectable (in intervals of 5 seconds) from once every 5 seconds to once a day.
- **Data Display**  
Numerical and graphical
- **Real Time Recording**  
Device can be programmed to monitor, record and graphically present data in real time directly to PC.

### Guide to Installation

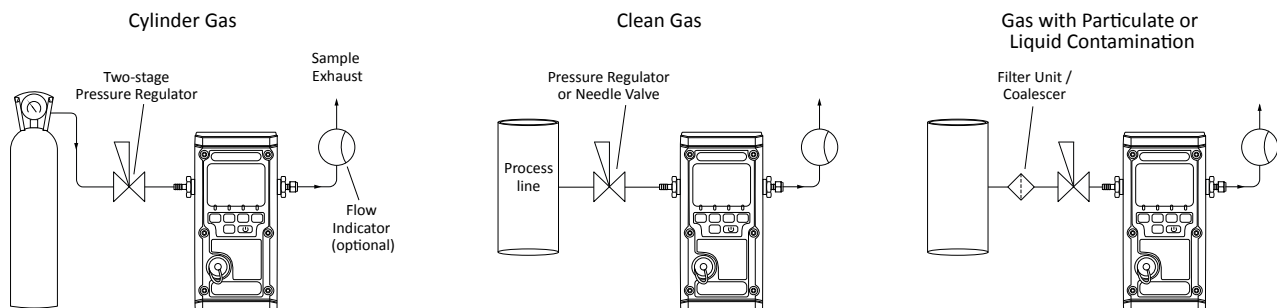

**Ordering Information**

**Model SDHmini-Ex - (X) - (X) - (X)**

**Choose required range in dewpoint = X**

- P (Purple):** -100 to 0 °C dewpoint 0 - 6000 ppm(v)
- S (Silver):** -100 to -20 °C dewpoint 0 - 1000 ppm(v)
- G (Grey):** -80 to 0 °C dewpoint 0 - 6000 ppm(v)
- R (Red):** -80 to -20 °C dewpoint 0 - 1000 ppm(v)
- B (Blue):** -80 to +20 °C dewpoint 0 - 23000 ppm(v)

**SAMPLE CONNECTION = X**

SDHmini-Ex instrument supplied with 1 x Fir Tree connection for outlet. Please specify inlet connection.

- 4:** 0.25" (1/4") Swagelok SS Compression Type
- 6:** 6 mm Swagelok SS Compression Type
- 8:** 0.125" (1/8") Swagelok SS Compression Type
- F:** Fir Tree connection to suit 6 mm PTFE sample tube

**PLEASE NOTE:**

If not specified at time of order, 1 x 1/4" and 1 x Fir Tree will be supplied.

**EXAMPLE:**

To order device with range -80 °C to 0 °C dewpoint with 6 mm pipe connection, for use in UK, order as:

**Model SDHmini-Ex - G - 6 - UK**

**MAINS PLUG TYPE -**

**For Battery Charger = X**

**UK, US, EU, AU, KR, AR, IN, CN, BR, ZA** (please see diagrams below)

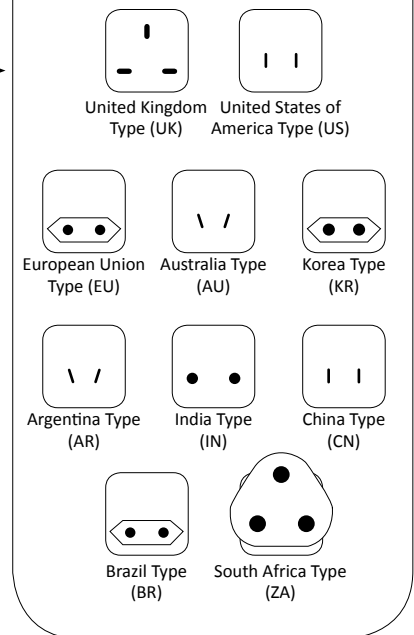

**Related Products**

**Service Kit Includes:**

- Desiccant
- Head seal kit
- Grommet
- Silicone grease
- Batteries

**Bluetooth Mobile Printer**

- IP54 rated rugged design
- 1.2 m drop resistant
- Long-lasting battery life
- High printing speed
- Slim, lightweight design
- Low temp (-15 °C) printing



**Includes as Standard**

- SDHmini-Ex instrument
- Anti-static carry case
- Allen Key
- USB charging cable
- Fir Tree fitting plus 1 x fittings as ordered
- AC/DC adaptor
- Calibration Certificate
- Two metres PTFE sampling hose
- Pressure calculator
- USB flash drive with Shaw
- SDHmini User Tool Software Instruction Manual
- SHAW SDHmini-Ex User Tool Manual

