

HUCK® INTERACTIVE CD ROM : SPECIFICATIONS

2503

2503 Hydraulic Installation Tool

Specifications

Weight:

2.1 kg (4.62 lbs.)

Stroke:

38 mm (1.5")

Max Operating Hydraulic Pressures:

Pull- *393 bar (*5700 psi)

Return-165 bar (2400 psi)

* For 9.5 mm (3/8") MG use 579
bar (8400 psi)

Capacity:

33.13 kN @ 393 bar

(7447 lbs @ 5700 psi)

49 kN @ 579 bar

(11013 lbs @ 8400 psi)

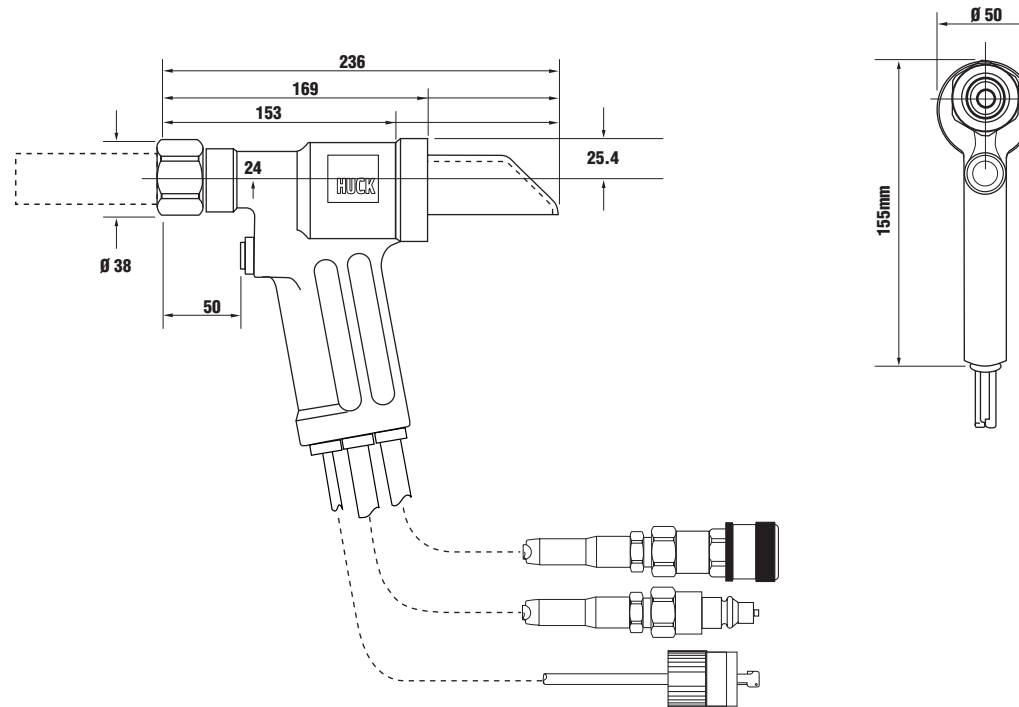

HUCK® INTERACTIVE CD ROM : NOSE ASSEMBLY TABLE

2503

Some Fasteners & Nose Assemblies for use with the 2503 Tool

Type	Diameter	Nose Assembly
BOM	4.8 mm (3/16")	99-1053
	6.4 mm (1/4")	99-830-1
	7.9 mm (5/16")	99-769
	9.5 mm (3/8")	99-1272
MAGNA-LOK	9.5 mm (3/8")	99-3318
MAGNA-BULB	7.9 mm (5/16")	99-3307
C6L/C120L	4.8 mm (3/16")	99-2558
	6.4 mm (1/4")	99-2564
	7.9 mm (5/16")	99-99-245
	9.5 mm (3/8")	99-100-245
MAGNA-GRIP	4.8 mm (3/16")	99-3206
	6.4 mm (1/4")	99-3207
	7.9 mm (5/16")	99-1439
	9.5 mm (3/8")	99-1440
HUCKTAINER	9.5 mm (3/8")	99-3438
FLOORTIGHT	7.9 mm (5/16")	99-3452

Items in **bold** are part of our FOCUS Tooling Range