

ETCR[®] H/L VOLTAGE CLAMP METER

ETCR 9000
ETCR 9000B

<http://www.etcrc.com>

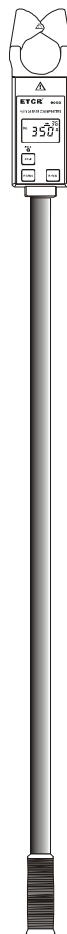
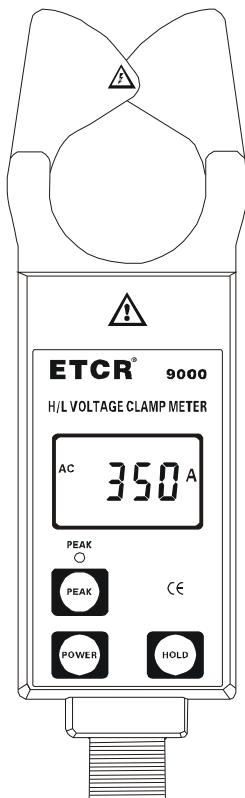

MANUAL

Guangzhou ETCR Electronic Technology Co., Ltd

CONTENT

Warning.....	1
I . Brief Introduction	3
II. Electrical Symbols	4
III. Series Model	4
IV. Technical Specification	5
V. Structure	7
VI. LCD Display.....	8
VII. Operation.....	10
A. Tester Operation	10
1. Power On/Off.....	10
2. General Test	10
3. PEAK Test.....	13
4. Data Maintenance	13
5. Data Memory	13
6. Data Reference.....	13
7. Data Deletion	14
*8. Data Transmission.....	14
B .Operation of Receiver	14
1. Power On/Off.....	14
2. Data Reception.....	15
3. Data Maintenance	15
4. Data Memory	15

5. Data Reference	15
6. Data Deletion	16
VIII. Replacing Batteries	16
IX. Accessories	17



Warning





Thanks for your purchase of **ETCR9000 H/L Voltage Clamp Meter** of our company. In order to make better use of this product, please make sure to:

—**Read this manual in detail and the operator must totally understand this manual and be in proficient in operation of this meter before making test on spot.**

—**Strictly comply with the security rules and notice items listed on this manual.**

- ⊍ In any case, it should pay special attention to safety in use of this meter, particularly in measurement of circuitry with more than AC100V and above voltages.
- ⊍ If the voltage of tested circuitry has exceeded 600V, it must be used by connecting with an insulation rod.
- ⊍ As it is very dangerous of high voltage transmission line, the operator must get strict training and the relevant certification on high-pressure operation of the state before using this meter and making a field test.
- ⊍ It is strictly forbidden to use this meter to test the wire without any insulate protection has voltage exceed 35KV or convergence generatrix.
- ⊍ Please pay attention to marked words and symbols on panel or backboard of this meter.
- ⊍ Please do not put or store this meter in the place of high temperature, with moisture, with frozen dew or with direct daylight irradiation for a long time.
- ⊍ Please note the battery polarity when replacing battery, and remove the battery if you expect not to use this meter for a long time.
- ⊍ It must be operated by qualified staff that has the authorization on tearing down or repairing this meter.
- ⊍ Please do not use it when there is any damage on the

transducer clamp or other parts of this meter.

- u To avoid the impact of transducer clamp, it needs to maintain this meter regularly. Do not use corrosive or coarse materials to clean, but use soft cloth (such as glasses cloth), dipping clean anti-rust desiccant lubricant (such as WD-40), and making a gentle wiping.
- u For the reason of this meter, in case that any danger may occur if continue to use it, stop using it immediately and seal it up for keeping at once, which shall be dealt with by qualified authorization agency.
- u The danger symbol “” on the meter and the manual, the user must make safe operation according to the indication.
- u The extremely dangerous symbol “”, the user must make safe operation according to the indication.
- u It suggests that this meter shall be made insulation intensity test at least once annually. (AC 100kV/rms between insulation pole and clamp core.)
- u As to the part with “*” mark in this manual, it is only limited to **ETCR9000B** type (wireless Transmission data type).





I . Brief Introduction

ETCR9000 Series H/L Voltage Clamp Meter has broken through the traditional structure, which is specially well-designed for measuring high voltage current, adopting the latest CT technology and integrated mask digital technology, formed by composition of a special use clamp meter with a high-voltage insulation rod, as to **ETCR9000B** type --- **wireless transmission of test data**, it is equipped with wireless receivers, which can receive measured data within 30 meters line. If not using an insulation rod, it can be also used as a high precision low-voltage clamp meter, or an alternating current meter, which can accurately measure 0.01mA of current or leakage current.

ETCR9000 Series H/L Voltage Clamp Meter has an innovative integrated design between transducer clamp and transducer domain, ensuring the high-precision, high-reliability, and high-stability on constant test perennially.

ETCR9000 Series H/L Voltage Clamp Meter is connected with insulation rod, which can be used for measuring high voltage current that is below 60KV, on-line current measurement, also having peak maintenance, data preservation, data storage, wireless transmission and other functions, and its special clamp meter can make it easier for clamping or evacuating the tested wire through pressing or pulling back the insulation rod, time-saving and fast, widely used in transformer substation, power plant, industrial and mining enterprises as well as the inspection station and electrician maintenance departments for electrical current detection and field electrical operations. It can also replace the H/L voltage transforming ratio tester, that is, to detect the high and low current for primary circuit and secondary circuit separately, and then calculate to conclude the change of high and low pressure. The insulation rod is light and convenient, with the advantages of anti-moisture, high temperature resistance, anti-impact, bending resistance, high insulation, flexibility and other characteristics.

II. Electrical Symbols

	Extremely Dangerous! The operator must strictly abide by the safety rules. Otherwise, there is electric injury danger, causing personal damage or casualty accident.
	Dangerous! The operator must strictly abide by the safety rules. Otherwise, there is electric injury danger, causing personal damage or casualty accident.
	Warning! It must strictly abide by the safety rules. Otherwise, it may cause personal damage or casualty accident.
	Alternating Current (AC)
	Direct Current (DC)

III. Series Model

Model	Range of measurement	Accuracy	Jaw Specification	Description
ETCR 9000	0.00mA-1200A	0.01mA	φ48mm	base
ETCR 9000B	0.00mA-1200A	0.01mA	φ48mm	wireless

IV. Technical Specification

Function	High voltage AC current measurement, low voltage AC current, leakage current measurement, on-line AC current supervision.
Power Supply	DC6V Alkaline Dry Battery (1.5V AAA X 4)
Test Method	Clamp CT, Integral Method
*Transmission Method	B Model: Wireless Transmission, the maximum distance for direct transmission is about 30m.
Display Mode	4 digital LCD display, backlight function, suitable for dark place.
LCD Dimension	47mm×28.5mm
Meter Dimension	W/H/T: 76mm×255mm×31mm
Clamp Diameter	φ48mm
Sampling Speed	About 2 times/second
Range of measurement	0.00mA~1200A (50/60Hz Auto Identification)
Resolution	0.01mA
Shift	0.0mA~1200A Automatic Shift
Test Accuracy (23°C±5°C, Below 80%RH)	0.0mA~299mA: ±1%±3dgt
	0.30A~49.9A: ±1.5%±5dgt
	50.0A~199.9A: ±2.0%±5dgt
	200A~600A: ±3%±5dgt
	601A~1200A: ±4%±5dgt
Data Storage	99 Groups, during storage, the symbol "MEM" gives indication, "FULL" mark will flash to indicate the memory has been full.
Circuit Voltage	Test for the circuit below 60KV (operated with insulation rod)
Peak	Automatically maintain the height of the test

Maintenance	value, usually in the test mode press PEAK key, PEAK lights, that is, to keep open the PEAK function, then press PEAK key to cancel this function
Data Preservation	Under general test mode, press HOLD button to preserve data, "HOLD" symbol display. then press HOLD Key to cancel this function
Data Access	"MR" symbol indicates, it can read the stored data by turning upwards and downwards.
Overflow Display	Exceed measurement range overflow function: "OL A" symbol display
* No signal Indication	When the receiver has not received transmit signal, it will display "no- "symbol
Auto Shut Down	About 15 minutes after booting, the meter will shut down automatically, in order to decrease the battery consumption.
Battery Voltage	When the battery voltage is below 4.8V, the symbol of battery voltage "  "will show to remind to replace battery.
Weight	Tester: About 335g (Including battery), total quality of meter: about 2.5Kg (including insulation rod and battery.)
Work Temperature and Humidity	-10°C ~40°C; Below 80%Rh
Storage Temperature and Humidity	-10°C ~60°C; Below 70%Rh
Insulated Rod Dimension	φ32mm, 1m/Section (5 Sections)
Insulation Intension	AC 100KV/rms (Between insulation rod and clamp core)
Structure	Anti-Dripping Type II

V. Structure

1. Double input toroid (including the boot area)
2. ETCR9000 Tester
3. LCD Display
4. **PEAK** Key
5. **PEAK** Key
7. **HOLD** Key
9. Insulation Rod Connector
- *11.ETCR9000B Testers
4. **PEAK** Test Indication
6. **POWER** Key
- *8. ETCR9000B Receiver
- *10. **POWER** Indication

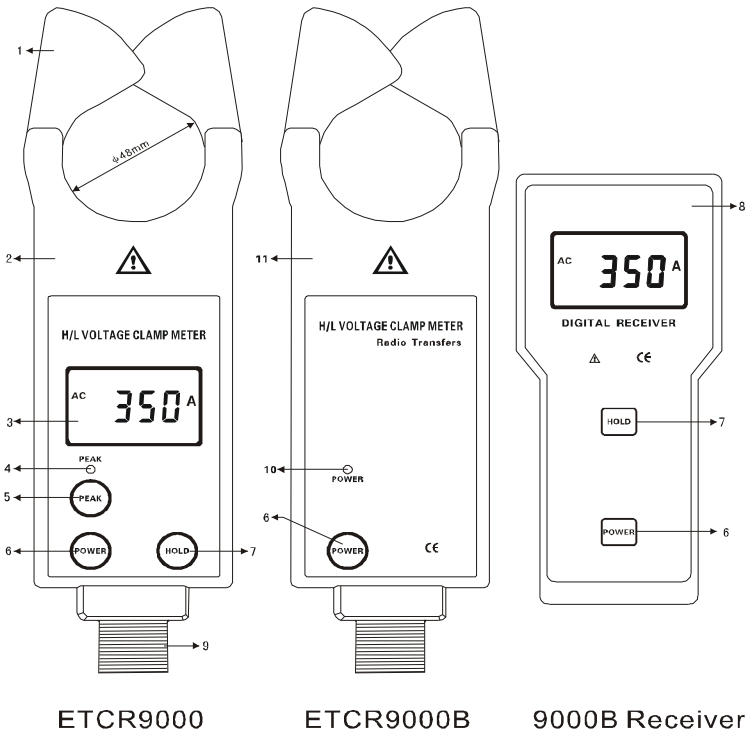



VI. LCD Display

1. LCD Display Screen

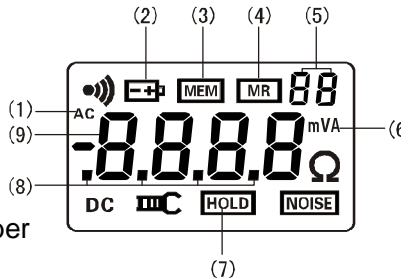
- (1). AC symbol
- (2). Low battery symbol
- (3). Date storage symbol
- (4). Date access symbol
- (5). 2-digit storage data serial number
- (6). Unit symbol
- (7). Date locked symbol
- (8). Decimal system radix point
- (9). 4-Digit LCD digital display



2. Explanation for Special Symbols

- (1).  Low battery symbol, when the voltage of battery is lower than 4.8V, this symbol display, please replace battery in time.
- (2). “OL A” This symbol indicates that the current on test has exceeded the maximum measurement limit of the meter.
- (3).  “MEM” Memory mode, it will display during the data storage process.
- (4). “Full” symbol, when the storage memory has been filled with 99 groups of data, it will display “FULL” symbol by flash, which means it cannot continue to store data.
- (5).  “MR” data access symbol, which is displayed during looking up data, meanwhile, it will display the serial number of data in storage.
- (6). “End” exit symbol, it will display during the exit.

(7).“**dEL**” data delete symbol, it will display when deleting data.

* (8).“**no- -**” None received signal instructions, dynamic display, it may not in test mode, or adjust the location and distance from receiver.

3. Display Demonstration

(1). —The current on test is 0.002A (2mA)



(2). —Locked display Data
—The data is automatic stored as group 3
—The current on test is: 160.5A

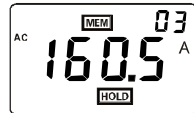

(3). —The current on test is: 571A
—Low battery symbol, please replace.



(4). —Look up data of group 3 in storage
—The current on test is: 160.5A



(5). —“FULL” flash display:
Storage is full of 99 groups
—It can't store more unless delete storage

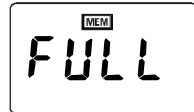

(6). —“**dEL**” Indication of data delete

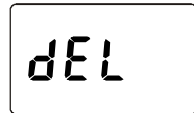

(7). —“**End**” Indication of exit



* (8). —“**no- -**” Dynamic display: none received signal

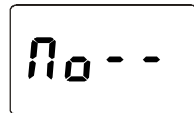

VII. Operation

	Please check all parts of the meter carefully before usage, to see whether there is any damage. And make sure no damage before usage.
	According to manual instructions to install the battery

A. Tester Operation

1. Power On/Off

Press **POWER** button to power on, the instrument will displays the LCD screen, entering normal testing mode. If LCD display is relatively dark after power on, it is possible that battery voltage is a bit lower. Please replace battery. 15 minutes after powering on the meter, if it remains idle, an auto-power off procedure starts to preserve the battery life and LCD will continue flash until the complete switch off takes place after 30 seconds. In case of LCD continuous flash, press **POWER** button, then the meter will continue to work.

Under HOLD mode, press **POWER** button for power off.
Under general test mode, press **POWER** button to power off.

Under **PEAK** testing mode, press **POWER** button to power off. Under data reference mode, firstly press **POWER** button for more than 3 seconds to exit from data reference mode, returning to normal test mode, then press **POWER** button to power off. During the exit from data access, it will display “End” symbol.

2. General Test

	High voltage, extremely dangerous! It must be operated by qualified staff that has acquired authority. The operator must strictly abide by the
-------------------------------------------------------------------------------------	------------------------------------------------------------------------------------------------------------------------------------------------

	safety rules. Otherwise, there is electric injury danger, causing personal damage or casualty accident.
	Dangerous! It cannot be used to measure the circuit over 35KV voltage. Otherwise, there is electric injury danger, causing personal damage or equipment damage.
	Dangerous! It cannot be used to measure the circuit over 1200A voltage. Otherwise, there is electric injury danger, causing personal damage or equipment damage.

General Test: In the process of test, LCD will display the tested current value real time, and LCD data will vary with the current change. When the tester is removed away from the lead on test, it does not preserve the test result, LCD display will return to zero.

In normal testing mode, it is suitable for close distance measurement, convenient for circuit test by direct read of LCD data.

	Before test, firstly to connect insulation rod, which must be connected in right position, and then to connect tester, avoiding the impact of meter to ground surface.
	Make sure to use specially equipped insulation rod to connect with the meter.
	After test, it should incline the insulation rod accordingly on drawing in. Firstly to tear down the tester and then the insulation rod, avoiding the impact of meter to ground surface.

After normal boot, place the lead in the middle of clamp transducer domain, as shown in **Figure A**, with the meter transducer domain perpendicular to the lead, pushing the meter forwards to clamp the lead on test, showing the result on LCD display. If showing "OL A", it means the lead current on test has exceeded the maximum volume on the level. Please select a higher gear level or a meter with greater measurement limit.

To pull backwards can make the meter remove from the

lead on test, as shown in **Figure C**, please try to keep the meter transducer domain perpendicular to the lead when moving away .

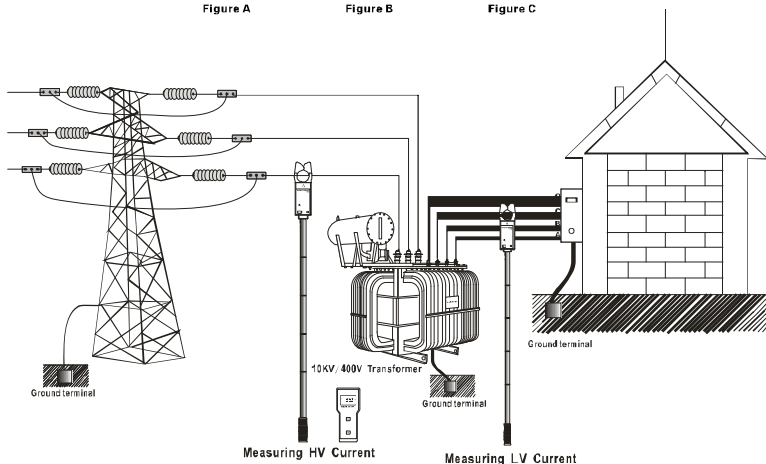
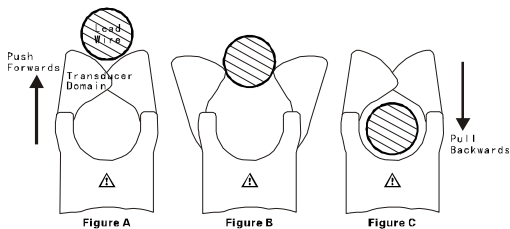

Under **HOLD** mode, press **HOLD** button to cancel HOLD function, and return to normal testing mode.

Under data reference mode, press **POWER** button for more than 3 seconds to exit from data reference mode, returning to normal testing mode.

Under **PEAK** testing mode, press **POWER** button to exit from **PEAK** testing mode, returning to normal testing mode.

After data deletion, it will return to normal testing mode automatically.

	Attention! For the sake of safety, when test has been finished, please remove the meter away from the lead on test.
--	---------------------------------------------------------------------------------------------------------------------

3. PEAK Test

PEAK test: the maximum current test. The meter will make automatic comparison on the changes in measured current, indicating the maximum value and maintain it, when the meter is removed away from the lead on test, the test result will be kept consistently, suitable for the circuit test on those LCD data hard to be read directly.

Under the normal testing mode, press **PEAK** button, **PEAK** indication light will be bright, enter **PEAK** testing mode. That means the meter will display and automatically keep the maximum value in the test.

Under any other mode, it must be returned to normal testing mode, and then make PEAK testing according to the above operation.

Press **POWER** button to exit from PEAK testing mode, returning to normal testing mode, and it will display “End” symbol during the exit.

4. Data Maintenance

Under normal testing mode, press **HOLD** button to keep LCD display, “**HOLD**” symbol displays. Press **HOLD** button again to release data lock, returning to normal testing mode, and “**HOLD**” symbol disappears.

5. Data Memory

Under normal testing mode, press **HOLD** to storage data, at the same time, Meter will automatically form serial numbers, and memory the current preserved data. During the storage, “**MEM**” symbol will show once by flash. This meter can memory 99 groups of data, in case of full storage, “**FULL**” symbol will display by flash continuously, and it cannot continue to memory until cleaning out the previous memory.

6. Data Reference

Under normal testing mode, press **PEAK** + **POWER** button to enter data reference mode, displaying “**MR**” symbol, meanwhile, it will automatically display data saved in the group 01. Then press **PEAK** or **POWER** button to read the stored

data by turning upwards or downwards in cycle. It will return to the group 1's data automatically after reaching the last group's data in storage.

Press **HOLD** button to exit from data reference mode, returning to normal testing mode. During the exit, it will display "End" symbol.

7. Data Deletion

Under data reference mode, press **PEAK** + **POWER** button to delete all the data in storage, and return to normal testing mode. During the deletion of data, it will display "dEL" symbol.

*8. Data Transmission

B Type: has the function of wireless data transmission. When the Meter under testing mode, the test result will be transferred to receiver by wireless transmission and the receiver will display test result real time, being clear at a glance.

Only under testing mode, the meter will transmit, If the receiver has not received emission signals, it will display "no -" symbol dynamically.

B Type: Transferred

ETCR9000B Type: Wireless transmission test data, a straight-line distance of about 30 meters, can penetrate the floor to receive data.

B .Operation of Receiver

(Note: For ETCR9000B only)

1. Power On/Off

Press **POWER** button to power on, the instrument will displays the LCD screen, entering normal testing mode. If LCD display is relatively dark after power on, it is possible that battery voltage is a bit lower. Please replace battery. 15 minutes after powering on the meter, if it remains idle, an auto-power off procedure starts to preserve the battery life and LCD will continue flash until the complete switch off takes place after 30 seconds. In case of LCD continuous flash,

press **POWER** button, then the meter will continue to work.

Under **HOLD** mode, press **POWER** to power off.

Under data reference, first, press **POWER** button(for 3 seconds) to exit data reference mode, then come back to data receive mode, press **POWER** button once again to power off. During exit from data reference, it will display the symbol of “**End**”.

2. Data Reception

After normal power on, the receiver will under receiving mode. If there are emission data, the receiver will display the test result real time. If it has not received any signal, the receiver will search signals constantly, and display “**no-**”symbol dynamically.

3. Data Maintenance

Under Data Reception mod, press **HOLD** button, keep LCD display, “**HOLD**” symbol indication. Press **HOLD** button once again to relieve data lock, return to data reception mode, “**HOLD**” symbol display.

4. Data Memory

Under Date Reception mode, press **HOLD** button to maintain data, meanwhile, the receiver will automatically form serial numbers, and memory the current preserved data. During the storage, “**MEM**” symbol will display once by flash. The receiver can memory 99 groups of data, in case of full storage, “**FULL**” symbol will display by flash continuously, and it cannot continue to memory until cleaning out the previous memory.

5. Data Reference

Under Data Reception mode, press **HOLD+POWER** button to enter Data Reference mode, “**MR**” symbol display, meanwhile, it will automatically display data saved in the group 1. Then press **HOLD** button or **POWER** button to read the stored data by turning upwards or downwards in cycle. It will return to the group 1’s data automatically after reaching the last

group's data in storage.

Press **POWER** button for more than 3 seconds to exit from data reference mode, returning to receiving data mode. During the exit, it will show “**End**” symbol.

6. Data Deletion

Under data reference mode, press **HOLD** + **POWER** button to delete all the data in storage, and return to Data Reception mode. During the deletion of data, it will display “**dEL**” symbol.

VIII. Replacing Batteries

	Warning! In case that the battery's cover board is not well closed, it is forbidden to make test. Otherwise, it is dangerous.
	Pay attention to the polarity of battery, in case of damage to the meter.
	Do not mix in the use of new and old batteries.

1. When the battery voltage is below 4.8V, the meter will display “**- +**” symbol, indicating the batteries have no sufficient power content. Please replace batteries.
2. Power off, to make sure the meter is under the state of power off. To loosen two screws of the battery cover board, open the cover board to replace brand-new qualified batteries on. It should pay special attention on the battery specification and polarity, cover the board well and fasten the two screws.
3. Press **POWER** button to check whether the meter can be powered on normally. If not, please repeat the operation according the step 2.

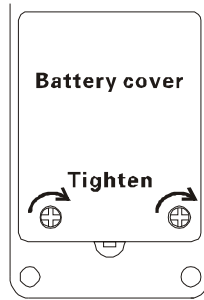
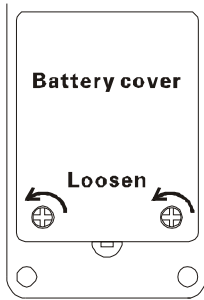

IX. Accessories

Tester	1PCS
*Receiver (ETCR 9000B special)	1PCS
Insulation Rod (1M/Section)	5 Sections
Meter Box	1PCS
Battery (Alkaline Dry Battery AAA)	4 PCS (* or 8 PCS)
User's Manual/ Maintenance Card/ Conformity Certificate	1SET

 **Manufactured by**

ETCR Electronic Technology Company

Address: F-3F, No.4 Pengshang Zhifu Road, Jiahe, Baiyun District, Guangzhou, Guangdong, China

Post Code: 510440

Tel: (86-20)62199556 62199554

Fax: (86-20)62199550

E-mail: info@etcr.cc

Website: www.etcr.cc