

General Specifications

YTA710 Temperature Transmitter



GS 01C50G01-01EN

The YTA710 is the highly accurate temperature transmitter that accepts Thermocouple, RTD, ohms or DC millivolts inputs and converts it to a 4 to 20 mA DC or Fieldbus signal for transmission.

The YTA710 supports HART® and FOUNDATION fieldbus™ communication protocols.

■ FEATURES

High reliability

Dual-compartment housing realizes high resistance capability to harsh environments.

Variety of sensor inputs

The type of sensor input is user-selectable from thermocouples (T/C), RTDs, ohms, or DC millivolts.

Digital communication

HART protocol revision is 7 and FOUNDATION fieldbus™ ITK version is 6.1.

The instrument configuration can be changed by the user with using the Fieldmate or Handheld terminal.

Local Parameter Setting

Parameter configuration by the push button offers easy and quick setup for parameters.

Self-diagnostics function

Continuous self-diagnostics capability ensures longterm performance and lower cost of ownership.

Dual universal inputs

Dual input can accept two thermocouple, RTD, ohm or DC millivolt inputs. Differential or average temperature measurement is selectable. The sensor backup function for automatically switches-over from the primary to the backup upon sensor failure.



■ STANDARD SPECIFICATIONS

■ PERFORMANCE SPECIFICATIONS

Accuracy

HART communication type:
A/D accuracy/span + D/A accuracy
(See Table 1 on page 4.)

Fieldbus communication type:
A/D accuracy (See Table 1 on page 4.)

Cold Junction Compensation Accuracy

$\pm 0.5^{\circ}\text{C}$ ($\pm 0.9^{\circ}\text{F}$) for T/C only
Include influence of the ambient temperature.

Ambient Temperature Effect (per 10°C change)

$\pm 0.1\%$ or $\pm(\text{Temperature coefficient}/\text{span})$, whichever is greater. (See Table 2 on page 5.)

Stability

RTD: $\pm 0.1\%$ of reading or $\pm 0.1^{\circ}\text{C}$ per 2 years,
whichever is greater at $23\pm 2^{\circ}\text{C}$.
T/C: $\pm 0.1\%$ of reading or $\pm 0.1^{\circ}\text{C}$ per year, whichever is greater at $23\pm 2^{\circ}\text{C}$.

5 Year Stability

RTD: $\pm 0.25\%$ of reading or $\pm 0.25^{\circ}\text{C}$,
whichever is greater at $23\pm 2^{\circ}\text{C}$.
T/C: $\pm 0.5\%$ of reading or $\pm 0.5^{\circ}\text{C}$,
whichever is greater at $23\pm 2^{\circ}\text{C}$.

Vibration Effect

The YTA710 are tested to the following specifications with no effect on performance per IEC 60770-1
10 to 60 Hz 0.21 mm peak displacement
60 to 2000 Hz 3g

Power Supply Effect

$\pm 0.005\%$ of calibrated span per volt

FUNCTIONAL SPECIFICATIONS

Input signals

Input number: single and dual input
 Input type is selectable: Thermocouples, 2-, 3-, and 4-wire RTDs, ohms and DC millivolts.
 See Table 1. on page 4.

Input signal source resistance (for T/C, mV)

1 kΩ or lower

Input lead wire resistance (for RTD, ohm)

10 Ω per wire or lower

Span & Range Limits

See Table 1. on page 4.

Output signals

Two wire 4 to 20 mA DC Type

Output range: 3.68 to 20.8 mA
 HART® protocol is superimposed on the 4 to 20 mA signal. Any single value among followings can be selected as the analog output signal.
 Sensor 1, Terminal Temperature.
 Dual input type, same as above plus;
 Sensor 2, Average, and Differential Temperature.
 Also, up to three of the above values can be displayed on LCD display or read via communication.

Fieldbus communication Type

Output signal based on FOUNDATION fieldbus™ communication protocol.

Isolation

Input/Output/GND isolated to 500V DC
 Except lightning protector option.

Manual Test Output Function

The output value can be set manually.

Sensor Burnout (HART Type)

High (21.6 mA DC) or Low (3.6 mA DC), user selectable.

Output in Transmitter Failure (HART Type)

Down-scale: -5%, 3.2 mA DC or less , sensor burnout -2.5%, 3.6 mA (Optional code C1)
 Down-scale: -5%, 3.2 mA DC or less (Optional code C2)
 Up-scale: 110%, 21.6 mA DC or more (Standard or Optional code C3)

Update Time (HART Type)

Approximately 0.5 seconds for a single sensor (0.8 second for dual sensors) at damping time 0

Turn-on Time (HART Type)

Approximately 6 seconds for a single sensor (7 seconds for dual sensors)

Damping Time Constant

Selectable from 0 to 100 seconds

Self-Diagnostics

Self-diagnostic function based on the NAMUR NE107 standard detects failures in the hardware, configuration and communications.

Sensor-Diagnostics

Sensor drift, temperature cycle detect, and corrosion of the sensor.

Fieldbus functions (Fieldbus Type)

Functional specifications for Fieldbus communication conform to the standard specifications (H1) of FOUNDATION Fieldbus.

Function Block (Fieldbus Type)

Resource block

The resource block contains physical transmitter information.

Transducer block

The transducer block contains the actual measurement data and information about sensor type and configuration and diagnostics.

LCD display block

The LCD display block is used to configure the local display, if an LCD display is being used.

Analog input (AI)

Four independent AI blocks can be selected.

Digital input (DI)

Four DI function blocks can be used as a limit switch for those temperature.

Other Function block

As other Function blocks, Arithmetic (AR), Signal Characterizer (SC), Input Selector (IS), and two PID function blocks are available.

Function block	Execution time (ms)
AI	30
DI	30
SC	30
IS	30
AR	30
PID	45

Link master function

This function enables backup of network manager and local control only by field devices.

Alarm function

Fieldbus models securely support various alarm functions, such as High/Low alarm, notice of block error, etc. based on FOUNDATION fieldbus specifications.

Software download function

This function permits to update YTA software via a FOUNDATION fieldbus.

EMC Conformity Standards

EN61326-1 Class A, Table2
 EN61326-2-3
 EN61326-2-5 (for fieldbus)

Safety Requirement Standards

EN61010-1, C22.2 No.61010-1
 • Altitude of installation site:
 Max. 2,000 m above sea level
 • Installation category: I
 (Anticipated transient overvoltage 330 V)
 • Pollution degree: 2
 • Indoor/Outdoor use
 EN61010-2-030, C22.2 No.61010-2-030
 • Measurement category: O (Other)
 (Measurement Input voltage: 150mVdc max)

■ NORMAL OPERATING CONDITION

(Optional features or approval codes may affect limits.)

Ambient Temperature Limits

- 40 to 85°C (–40 to 185°F)
- 30 to 80°C (–22 to 176°F) (with indicator model)

Ambient Humidity Limits

0 to 100% RH at 40°C (104°F)

Supply Voltage Requirements

HART Type

- 10.5 to 42 V DC for general use and flameproof type
- 10.5 to 32 V DC for lightning protector (option code /A)
- 10.5 to 30 V DC for intrinsically safe and non-incendive type
- Minimum voltage limited at 16.6 V DC for digital communications HART
- With 24 V DC supply, up to a 550Ω load can be used. See graph below.

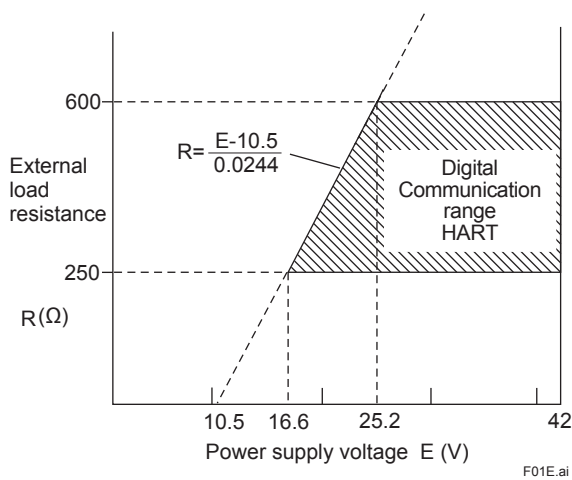

Figure 1. Relationship Between Power Supply Voltage and External Load Resistance

Fieldbus Type

- 9 to 32V DC for general use and flameproof type
- 9 to 30 V DC for intrinsically and non-incendive type
- 9 to 17.5 V DC for FISCO field device
- Communication Requirements
- Supply Voltage: 9 to 32 V DC
- Current Draw:
 - Steady state: 15 mA (max)
 - Software download state: 24 mA (max)

Load Requirements (HART Type)

- 0 to 1290Ω for operation
- 250 to 600Ω for digital communication

■ PHYSICAL SPECIFICATIONS

Enclosure

Material & Coating

Low copper cast aluminum alloy with polyurethane, mint-green paint. (Munsell 5.6BG 3.3/2.9 or its equivalent), or ASTM CF-8M Stainless Steel

Degrees of Protection

IP66/IP67, TYPE 4X

Name plate and tag

316 SST

Mounting

Optional mounting brackets can be used either for two-inch pipe or flat panel mounting.

Terminal Screws

M4 screws

Integral Indicator (with indicator model)

5-digit numerical display, 6-digit unit display and bar graph.

Local Parameter Setting (with indicator model)

Parameter configuration by the push button offers easy and quick setup for parameters. Accessible parameters are different with each output cord.

Weight

Aluminum housing:

- 1.3 kg (2.9 lb) without integral indicator and mounting
- Integral indicator: 0.2 kg (0.4 lb)
- Bracket for horizontal pipe: 0.3 kg
- Bracket for vertical pipe: 1.0 kg

Stainless housing:

- 3.1 kg (6.8 lb) without integral indicator and mounting
- Integral indicator: 0.3 kg (0.7 lb)

Connections

Refer to "MODEL AND SUFFIX CODE."

Table 1. Sensor type, measurement range, and accuracy

Sensor Type		Standard	Measurement Range		Minimum Span	A/D Accuracy		D/A Accuracy
			°C	°F		°C	°F	
T/C	B	IEC60584	100 to 300	212 to 572	25°C (45°F)	±3.0	±5.4	±0.02% of span
			300 to 1820	572 to 3308		±0.75	±1.35	
	E		-200 to -50	-328 to -58		±0.35	±0.63	
			-50 to 1000	-58 to 1832		±0.16	±0.29	
	J		-200 to -50	-328 to -58		±0.25	±0.45	
			-50 to 1200	-58 to 2192		±0.20	±0.36	
	K		-200 to -50	-328 to -58		±0.5	±0.9	
			-50 to 1372	-58 to 2502		±0.25	±0.45	
	N		-200 to -50	-328 to -58		±0.8	±1.44	
			-50 to 1300	-58 to 2372		±0.35	±0.63	
	R		-50 to 0	-58 to 32		±1.0	±1.8	
			0 to 600	32 to 1112		±0.6	±1.08	
S	600 to 1768	1112 to 3214	±0.4	±0.72				
	-50 to 0	-58 to 32	±1.0	±1.8				
T	0 to 600	32 to 1112	±0.5	±0.9				
	600 to 1768	1112 to 3214	±0.4	±0.72				
C	-200 to -50	-328 to -58	±0.25	±0.45				
	-50 to 400	-58 to 752	±0.14	±0.25				
W3	ASTM E988	0 to 400	32 to 752	±0.7	±1.26			
		400 to 1400	752 to 2552	±0.5	±0.9			
		1400 to 2000	2552 to 3632	±0.7	±1.26			
		2000 to 2300	3632 to 4172	±0.9	±1.62			
L	DIN43710	0 to 400	32 to 752	±0.8	±1.44			
		400 to 1400	752 to 2552	±0.5	±0.9			
U	DIN43710	1400 to 2000	2552 to 3632	±0.6	±1.08			
		2000 to 2300	3632 to 4172	±0.9	±1.62			
RTD	Pt100	IEC60751	-200 to 850	-328 to 1562	10°C (18°F)	±0.1	±0.18	
			-200 to 850	-328 to 1562		±0.22	±0.396	
	-200 to 850		-328 to 1562	±0.14		±0.25		
	-200 to 300		-328 to 572	±0.1		±0.18		
	JPt100		—	-200 to 500		-328 to 932	±0.1	±0.18
	Cu10		SAMA RC21-4	-70 to 150		-94 to 302	±1.0	±1.8
	Ni120		—	-70 to 320		-94 to 608	±0.08	±0.144
mV	—	-10 to 120 [mV]		3 mV	±0.012 [mV]			
ohm	—	0 to 2000 [Ω]		20 Ω	±0.35 [Ω]			

Note 1: Total Accuracy = (A/D Accuracy / Span + D/A Accuracy) or (± 0.1% of calibrated span), whichever is greater.

Accuracy of Fieldbus type: A/D Accuracy.

For T/C input, add Cold Junction Compensation Error (± 0.5°C) to the total accuracy.

Example: when selecting Pt100 with measurement range of 0 to 200 °C

0.1°C / 200°C × 100% of span + 0.02% of span = 0.07% of span

Since the value is smaller than ±0.1% of span, the total accuracy is ±0.1%.

Note 2: T/C C type is same as W5 (ASTM E988).

Table 2. Temperature coefficient

Sensor Type		Temperature Coefficient
Thermocouples E, J, K, N, T, L, U		0.08°C + 0.02% of abs.reading
Thermocouples R, S, W3, C		0.25°C + 0.02% of abs.reading
Thermocouple B	100°C ≤ Reading < 300°C	1°C + 0.02% of abs.reading
	300°C ≤ Reading	0.5°C + 0.02% of abs.reading
RTD		0.08°C + 0.02% of abs.reading
mV		0.002 mV + 0.02% of abs.reading
ohm		0.1 Ω + 0.02% of reading

Note1: The “abs.reading” for thermocouples and RTD means the absolute value of the reading in °C.

Example of “abs.reading”

When the temperature value is 250 Kelvin, “abs.reading” is 23.15.

$|250 - 273.15| = 23.15$

Note2: Ambient Temperature Effect per 10 °C change is ±0.1% or ±(temperature coefficient/span), whichever is greater.

Example of Ambient Temperature Effect

Conditions:

- 1) Input Sensor: Pt100
- 2) Calibration Range: -100 to 100°C
- 3) Reading value: -50°C

Ambient Temperature Effect per 10°C

Temperature Coefficient/Span = $(0.08°C + 0.02/100 \times |-50°C|) / \{100°C - (-100°C)\} = 0.00045 \rightarrow 0.045\%$

Therefore, Ambient Temperature Effect is ±0.1%/10°C

MODEL AND SUFFIX CODES

Model	Suffix Codes	Description
YTA710	Temperature Transmitter
Output signal	-J..... -F.....	4 to 20 mA DC with digital communication HART 7 protocol Digital communication (FOUNDATION Fieldbus protocol)
—	A.....	Always A
Sensor input	1..... 2.....	Single Double
Housing code	A..... C.....	Aluminum Stainless
Electrical connection	0..... 2..... 4.....	G1/2 female 1/2 NPT female M20 female
Integral indicator	D..... N.....	Digital indicator with Local Operating Switch None
Mounting bracket	B..... D..... J..... K..... N.....	SUS304 stainless steel 2-inch horizontal pipe mounting bracket *1 SUS304 stainless steel 2-inch vertical pipe mounting bracket SUS316 stainless steel 2-inch horizontal pipe mounting bracket *1 SUS316 stainless steel 2-inch vertical pipe mounting bracket None
Option codes		/□ Optional specification

*1: For flat-panel mounting, please prepare bolts and nuts.

OPTIONAL SPECIFICATION

Item	Description	Code	
Lightning protector	Power supply voltage: 10.5 to 32 V DC Allowable current: Max. 6000A(8×20μs), repeating 1000A(8×20μs), 100 times	A	
Plating*1	Color change Amplifier cover only	Munsell code: N1.5 Black Munsell code: 7.5BG4/1.5, Jade green Metallic silver	P1 P2 P7
	Color change Amplifier and terminal Covers	Munsell code: 7.5 R4/14 Red	PR
	Coating change	High anti-corrosion coating	X2
	Output signal low-side in transmitter failure*2	Output signal Low-side: -5%, 3.2 mA DC or less. Sensor burnout is also set to 'Low': -2.5%, 3.6 mA DC.	C1
NAMUR NE43 compliant*2	Output signal limits: 3.8 mA to 20.5 mA	Failure alarm down-scale: output status at CPU failure and hardware error is -5%, 3.2 mA or less. Sensor burnout is also set to Low: -2.5%, 3.6 mA DC.	C2
		Failure alarm up-scale: output status at CPU failure and hardware error is 110%, 21.6 mA or more. In this case Sensor burnout is High: 110%, 21.6 mA DC.	C3
Data configuration*2	Description into "Descriptor" parameter of HART protocol (max. 16 characters)	CA	
Wired tag plate	SUS316 stainless steel tag plate wired onto transmitter	N4	
Sensor matching	RTD sensor matching function	CM1	

*1: Not applicable for Stainless housing.

*2: Not applicable for Fieldbus type

■ OPTIONAL SPECIFICATION (For Explosion Protected type)

Item	Description	Code
ATEX	[4-20mA & Fieldbus: Flameproof and dust ignition proof approval] Applicable Standard: EN 60079-0:2012+A11:2013, EN 60079-1:2007, EN 60079-31:2009 Certificate: KEMA 07ATEX0130 II 2 G Ex d IIC T6/T5 Gb, II 2 D Ex tb IIC T70°C, T90°C Db Ambient Temperature for Gas Atmospheres: -40 to 75°C for T6, -40 to 80°C for T5 Ambient Temperature for Dust Atmospheres: -30 to 65°C for T70°C, -30 to 80°C for T90°C Enclosure: IP66/IP67 Electrical Connection: 1/2 NPT female and M20 female*1	<p>KF2</p>
	4-20mA: [Intrinsically safe approval] Applicable Standard: EN 60079-0: 2012+A11:2013, EN 60079-11: 2012 Certificate No. FM16ATEX0019X II 1 G Ex ia IIC T5...T4 Ga Ambient Temperature: -40 to 70°C for T4, -40 to 50°C for T5 Enclosure: IP66/IP67 Entity Parameters: Supply/Output circuit: $U_i=30V$, $I_i=200mA$, $P_i=1.0W$, $C_i=22nF$, $L_i=0mH$ Sensor circuit: $U_o=6V$, $I_o=90mA$, $P_o=135mW$, $C_o=10\mu F$, $L_o=3.9mH$ Dielectric strength: 500 V a.c.r.m.s., 1 min [+ , - , C , 1 , 2 , 3 , 4 , 5] to Earth terminal [+ , - , C] to [1 , 2 , 3 , 4 , 5] [Flameproof and Dust Ignition Proof Approval] Same as KF2	<p>KU2</p>
	Fieldbus: [Intrinsically safe approval] Applicable Standard: EN 60079-0: 2012+A11:2013, EN 60079-11: 2012 Certificate No. FM16ATEX0019X II 1 G Ex ia IIC T4 Ga Ambient Temperature: -55 to 60°C Enclosure: IP66/IP67 FISCO field device Entity Parameters: Supply/Output circuit: $U_i=30V$, $I_i=300mA$, $P_i=1.2W$, $C_i=2.2nF$, $L_i=0mH$ Sensor circuit: $U_o=6V$, $I_o=90mA$, $P_o=135mW$, $C_o=10\mu F$, $L_o=3.9mH$ Dielectric strength: 500 V a.c.r.m.s., 1 min [+ , - , 1 , 2 , 3 , 4 , 5] to Earth terminal [+ , -] to [1 , 2 , 3 , 4 , 5] [Flameproof and Dust Ignition Proof Approval] Same as KF2	<p>KU25</p>

Item	Description	Code
IECEx	[4-20mA & Fieldbus: Flameproof and dust ignition proof approval] Applicable standard: IEC 60079-0:2011, IEC 60079-1:2007-04, IEC 60079-31:2008 Certificate: IECEx KEM 07.0044 Ex d IIC T6/T5 Gb, Ex tb IIIC T70°C / T90°C Db Ambient Temperature for Gas Atmospheres: -40 to 75°C (-40 to 167°F) for T6, -40 to 80°C (-40 to 176°F) for T5 Ambient Temperature for Dust Atmospheres: -30 to 65°C (-22 to 149°F) for T70°C, -30 to 80°C (-22 to 176°F) for T90°C Enclosure: IP66/IP67 Electrical Connection: 1/2 NPT female and M20 female*1	SF2
	4-20mA: [Intrinsically safe approval] Applicable Standard: IEC 60079-0: 2011, IEC 60079-11: 2011 Certificate No. IECEx FMG 16.0014X Ex ia IIC T5... T4 Ga Ambient Temperature: -40 to 70°C for T4, -40 to 50°C for T5 Enclosure: IP66/IP67 Entity Parameters: Supply/Output circuit: $U_i=30V$, $I_i=200mA$, $P_i=1.0W$, $C_i=22nF$, $L_i=0mH$ Sensor circuit: $U_o=6V$, $I_o=90mA$, $P_o=135mW$, $C_o=10\mu F$, $L_o=3.9mH$ Dielectric strength: 500 V a.c.r.m.s., 1 min [+ , - , C , 1 , 2 , 3 , 4 , 5] to Earth terminal [+ , - , C] to [1 , 2 , 3 , 4 , 5] [Flameproof and Dust Ignition Proof Approval] Same as SF2	SU2
	Fieldbus: [Intrinsically safe approval] Applicable Standard: IEC 60079-0: 2011, IEC 60079-11: 2011, Certificate No. IECEx FMG 16.0014X Ex ia IIC T4 Ga, Ambient Temperature: -55 to 60°C Enclosure: IP66/IP67 FISCO field device Entity Parameters: Supply/Output circuit: $U_i=30V$, $I_i=300mA$, $P_i=1.2W$, $C_i=2.2nF$, $L_i=0mH$ Sensor circuit: $U_o=6V$, $I_o=90mA$, $P_o=135mW$, $C_o=10\mu F$, $L_o=3.9mH$ Dielectric strength: 500 V a.c.r.m.s., 1 min [+ , - , 1 , 2 , 3 , 4 , 5] to Earth terminal [+ , -] to [1 , 2 , 3 , 4 , 5] [Flameproof and Dust Ignition Proof Approval] Same as SF2	SU25

Item	Description	Code
FM (US)	[4-20mA & Fieldbus: Explosionproof approval] Applicable standard: Class 3600, Class 3615, Class 3810, ANSI/NEMA250 Class I, Division 1, Groups A, B, C and D.; Class II/III, Division 1, Groups E, F and G. "FACTORY SEALD, CONDUIT SEAL NOT REQUIRED." Enclosure Ratings: TYPE 4X Temperature Class: T6 Ambient Temperature: -40 to 60°C (-40 to 140°F) Electrical Connection: 1/2NPT female*2	FF1
	4-20mA: [Intrinsically safe approval/non-incendive approval] Applicable standard: Class 3600:2011, Class 3610:2015, Class 3611:2004, Class 3810:2005, ANSI/ISA-60079-0:2013,ANSI/ISA-60079-11:2014, NEMA 250:2003, ANSI/IEC 60529:2004 (R2011) Intrinsically safe for Class I, II, III Division 1, Groups A, B, C, D, E, F, G, T5...T4 Class I Zone 0 AEx ia IIC T5...T4 Non-incendive for Class I, II, Division 2, Groups A, B, C, D, F, G, T5...T4 Class III, Division 1 T5...T4 Class I Zone 2 Group IIC T5...T4 Ambient Temperature: -40 to 70°C for T4, -40 to 50°C for T5 Enclosure Type 4X, IP66/IP67 Entity Parameters: Intrinsically safe for Supply/Output circuit: Ui=30V, Ii=200mA, Pi=1.0W, Ci=22nF, Li=0mH Sensor circuit: Uo=6V, Io=90mA, Po=135mW, Co=10µF, Lo=3.9mH Non-incendive for Supply/Output circuit: Ui=30V, Ci=22nF, Li=0mH Sensor circuit: Uo=6V, Io=90mA, Po=135mW, Co=10µF, Lo=3.9mH Dielectric strength: 500 V a.c.r.m.s.,1 min [+ , - , C , 1 , 2 , 3 , 4 , 5] to Earth terminal [+ , - , C] to [1 , 2 , 3 , 4 , 5] [Explosionproof approval] Same as FF1	FU1
	Fieldbus: [Intrinsically safe approval/non-incendive approval] Applicable standard: Class 3600:2011, Class 3610:2015, Class 3611:2004, Class 3810:2005, ANSI/ISA-60079-0:2013,ANSI/ISA-60079-11:2014, NEMA 250:2003, ANSI/IEC 60529:2004 (R2011) Intrinsically safe for Class I, II, III Division 1, Groups A, B, C, D, E, F, G T4 Class I Zone 0 AEx ia IIC T4 Non-incendive for Class I, II, Division 2, Groups A, B, C, D, F, G T4 Class III, Division 1 T4 Class I Zone 2 Group IIC T4 Ambient Temperature: -55 to 60°C Enclosure Type 4X, IP66/IP67 FISCO field device Entity Parameters: Intrinsically safe for Supply/Output circuit: Ui=30V, Ii=300mA, Pi=1.2W, Ci=2.2nF, Li=0mH Sensor circuit: Uo=6V, Io=90mA, Po=135mW, Co=10µF, Lo=3.9mH Non-incendive for Supply/Output circuit: Ui=30V, Ci=2.2nF, Li=0mH Sensor circuit: Uo=6V, Io=90mA, Po=135mW, Co=10µF, Lo=3.9mH Dielectric strength: 500 V a.c.r.m.s.,1 min [+ , - , 1 , 2 , 3 , 4 , 5] to Earth terminal [+ , -] to [1 , 2 , 3 , 4 , 5] [Explosionproof approval] Same as FF1	FU15

Item	Description	Code
CSA*3 FM (Canada)*4	[4-20mA & Fieldbus: Explosionproof approval] Applicable standard: C22.2 No.0, C22.2 No.0.4, C22.2 No.30, C22.2 No.94, C22.2 No.142, C22.2 No.157, C22.2 No.213, C22.2 No.61010-1 C22.2 No.61010-2-030 Class I, Groups B, C and D, Class II, Groups E, F and G, Class III. For Class I, Division2 Groups ABCD Locations "FACTORY SEALED, CONDUIT SEAL NOT REQUIRED" Enclosure TYPE 4X Temperature Class: T6 Ambient Temperature: -40 to 60°C Electrical Connection: 1/2 NPT female*2	CF1
	4-20mA: [Intrinsically safe approval/non-incendive approval] Applicable standard: CAN/CSA-C22.2 No. 0:2010 (R2015), CAN/CSA-C22.2 No. 94.1:2007 (R2012), CAN/CSA-C22.2 No. 94.2:2007 (R2012), C22.2 No.213:1987 (R2013), CAN /CSA-C22.2 No. 60079-0:2011, CAN/CSA-C22.2 No. 60079-11:2014, CAN/CSA-C22.2 No. 60529:2005 (R2010), CAN/CSA-C22.2 No. 61010-1:2012, CAN/CSA-C22.2 No. 61010-2-030:2012 Intrinsically safe for Class I, II, III, Division 1, Groups A, B, C, D, E, F, G, T5...T4 Ex ia IIC T5...T4 Ga Non-incendive for Class I, II, Division 2, Groups A, B, C, D, F, G T5...T4 Class III Division 1 T5...T4 Ambient Temperature: -40 to 70°C for T4, -40 to 50°C for T5 Enclosure Type: 4X, IP66/IP67 Entity Parameters: Intrinsically safe for Supply/Output circuit: Ui=30V, Ii=200mA, Pi=1.0W, Ci=22nF, Li=0mH Sensor circuit: Uo=6V, Io=90mA, Po=135mW, Co=10µF, Lo=3.9mH Non-incendive for Supply/Output circuit: Ui=30V, Ci=22nF, Li=0mH Sensor circuit: Uo=6V, Io=90mA, Po=135mW, Co=10µF, Lo=3.9mH Dielectric strength: 500 V a.c.r.m.s., 1 min [+ , - , C , 1 , 2 , 3 , 4 , 5] to Earth terminal [+ , - , C] to [1 , 2 , 3 , 4 , 5] [Explosionproof approval] Same as CF1	CU1
	Fieldbus: [Intrinsically safe approval/non-incendive approval] Applicable standard: CAN/CSA-C22.2 No. 0:2010 (R2015), CAN/CSA-C22.2 No. 94.1:2007 (R2012), CAN/CSA-C22.2 No. 94.2:2007 (R2012), C22.2 No.213:1987 (R2013), CAN /CSA-C22.2 No. 60079-0:2011, CAN/CSA-C22.2 No. 60079-11:2014, CAN/CSA-C22.2 No. 60529:2005 (R2010), CAN/CSA-C22.2 No. 61010-1:2012, CAN/CSA-C22.2 No. 61010-2-030:2012 Intrinsically safe for Class I, II, III, Division 1, Groups A, B, C, D, E, F, G T4 Ex ia IIC T4 Ga Non-incendive for Class I, II, Division 2, Groups A, B, C, D, F, G T4 Class III Division 1 T4 Ambient Temperature : -55 to 60°C Enclosure Type: 4X, IP66/IP67 FISCO field device Entity Parameters: Intrinsically safe for Supply/Output circuit: Ui=30V, Ii=300mA, Pi=1.2W, Ci=2.2nF, Li=0mH Sensor circuit: Uo=6V, Io=90mA, Po=135mW, Co=10µF, Lo=3.9mH Non-incendive for Supply/Output circuit: Ui=30V, Ci=2.2nF, Li=0mH Sensor circuit: Uo=6V, Io=90mA, Po=135mW, Co=10µF, Lo=3.9mH Dielectric strength: 500 V a.c.r.m.s., 1 min [+ , - , 1 , 2 , 3 , 4 , 5] to Earth terminal [+ , -] to [1 , 2 , 3 , 4 , 5] [Explosionproof approval] Same as CF1	CU15

*1: Applicable for Electrical Connection Code 2 and 4.
 *2: Applicable for Electrical Connection Code 2.
 *3: For Explosionproof approval.
 *4: For Intrinsically safe approval/non-incendive approval.

■ DIMENSIONS

Unit: mm (Approx. inch)

● 2-inch horizontal pipe mounting

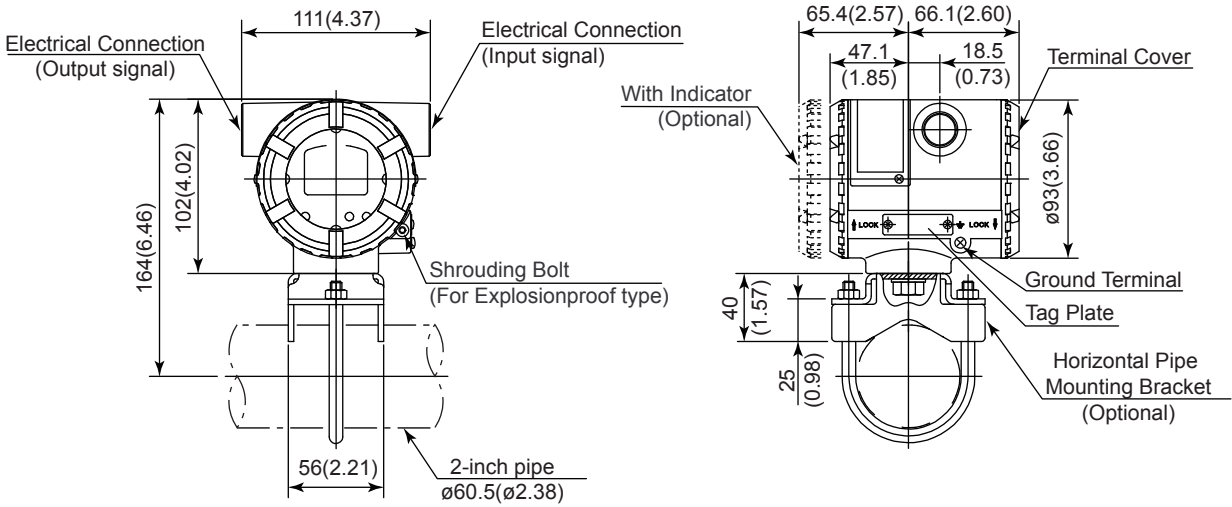

● 2-inch vertical pipe mounting

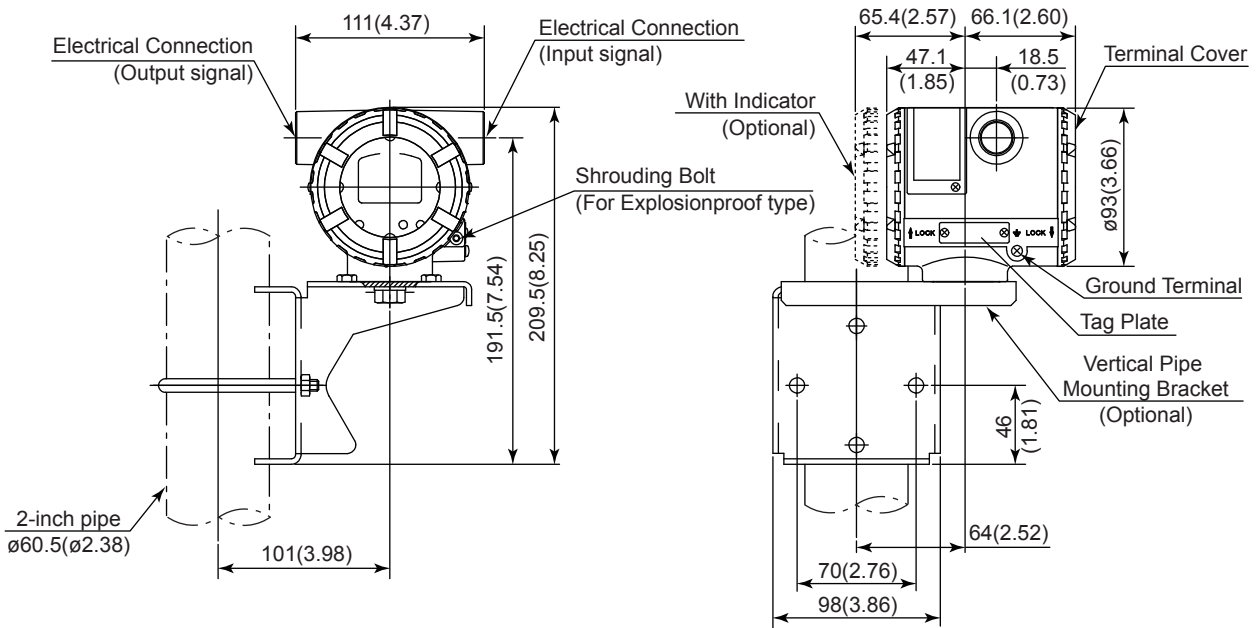

F02E.ai

● Terminals

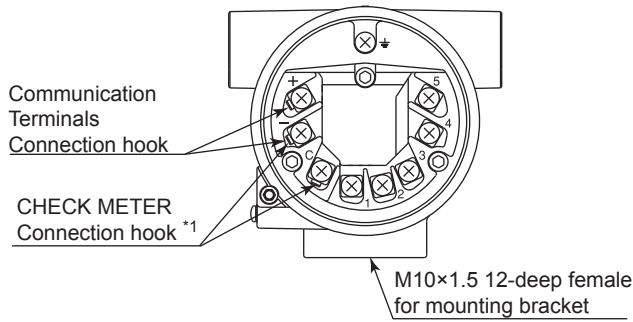

Terminal Configuration

+	Power supply and output terminal
-	External indicator (ammeter) terminal *1
⏏	Ground terminal

*1 : When using an external indicator or a check meter, the internal resistance must be 10Ω or less. The hook is not available for Fieldbus communication type.

F03E.ai

● Input Wiring

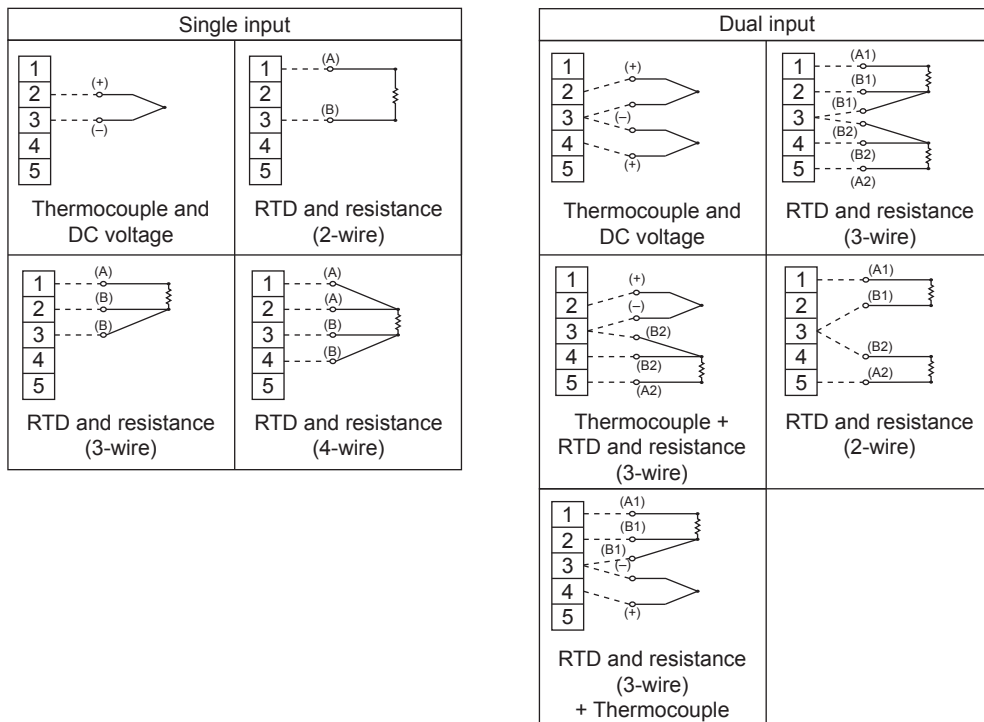

F04E.ai

< Ordering Information >

Specify the following when ordering Model, suffix codes, and optional codes.

If not specified, the instrument is shipped with the settings shown in Table A and B. Specify the following when necessary.

4-20mA Type (HART Type)

1. Sensor type.
For RTD and resistance input, specify the number of wire as well. (Example: Pt100 3-wire system)
For sensor input code-2, specify the type for two inputs.
2. Calibration range and unit
 - 1) Calibration range can be specified within the measurement range shown in Table 1. Also, set the upper limit is larger than the lower limit.
 - 2) Specify one range from °C, K, °F or °R for temperature input. It is not necessary to specify the unit of mV and ohm inputs, for these units automatically will be mV or Ω.
3. Tag Number (if required)
Specify Tag number (up to 16 Characters) to be engraved on the tag plate. The specified letters are written on TAG_Name (16 Characters) in the amplifier memory.
4. Software tag
Specified characters (up to 32 characters) are set as "Tag" (the first 8 characters) and "Long tag (32 characters) in the amplifier memory. Use alphanumeric capital letters. When the "SOFTWARE TAG" is not specified, "TAG NO" is set as "Tag" (the first 8 characters) and "Long tag" (32 characters) in the amplifier memory.
5. Other factory configurations
Specifying option code CA will allow further configuration at factory.
Descriptor (up to 16 characters)
6. Sensor back up
Select 'DISABLE' or 'ENABLE'.

Fieldbus Type

1. Sensor type.
For RTD and resistance input, specify the number of wire as well. For sensor input code-2, specify the type for two inputs. (Example: Pt100 3-wire system)
2. Calibration range (XD_SCALE)
For sensor input code-2, specify the range for two inputs.
3. Units of calibration range:
Specify only one unit from the table, 'Settings when shipped.' For sensor input code-2, specify the unit for two inputs.
4. Output mode (L_TYPE)
Select 'Direct' or 'Indirect.'
5. Output scale (OUT_SCALE)
For sensor input code-2, specify the scale for two inputs.
6. Output scale unit
Specify only one unit from the table, 'Settings when shipped.' For sensor input code-2, specify the unit for two inputs.

7. Tag Number
Specify Tag number (up to 16 Characters) to be engraved on the tag plate.
8. Software Tag (PD_TAG)
Specify software tag (up to 32 Characters) to be written on the amplifier memory.
9. Node Address
10. Operation Functional Class
Select 'BASIC' or 'LINK MASTER'.
11. Sensor back up
Select 'DISABLE' or 'ENABLE'.

< Factory Setting >

Table A. 4-20mA Type

Input sensor type *1	"Pt100" or as specified in order
Wire connection (For RTD) *1	"3-wire system" or as specified in order
Calibration range	"0 to 100" or as specified in order
Calibration unit	"°C" or as specified in order
Sensor burnout *2	High (110%, 21.6 mA DC)
Output in Transmitter failure *2	High (110%, 21.6 mA DC or more)
Sensor backup	'DISABLE' or as specified
Tag No.	"Blank" or as specified in order

- *1: For sensor input code-2, sensor 2 is set in nonconnection.
- *2: Except when Optional code C1 or C2 is specified.

Table B. Fieldbus Type

Input sensor type *1	"Pt100" or as specified in order
Wire connection (For RTD) *1	"3-wire system" or as specified in order
Calibration range *1	"0 to 100" or as specified in order
Calibration unit	"°C" or as specified in order
Output Scale *1	"0 to 100%"
Output mode	"Direct"
Node Address (in hexadecimal)	'0xF3' unless otherwise specified in order
Operation functional Class	'BASIC', or as specified in order
Sensor backup *2	'DISABLE' or as specified in order
Tag Number (Tag plate)	"Blank" or as specified in order
Software Tag (PD_TAG)	'TT1001' unless otherwise specified in order.

- *1: For sensor input code-2, sensor 2 is set in nonconnection.
- *2: Channel settings of AI function blocks depend on sensor backup setting.
Disable: AI1=Sensor1, AI2=Terminal temperature
Enable: AI1=Backup temperature, AI2=Terminal temperature