

Keysight Technologies

U2741A USB Modular Digital Multimeter

[Data Sheet](#)



Features

- Makes fast measurements with up to 100 readings per second
- Measure up to 300 VDC with 5½-digits resolution
- Frequency and temperature measurement capability
- Wide voltage measurement range
 - DC: 1 μ VDC to 300 VDC
 - AC: 1 μ Vrms to 250 Vrms
 - Wide current measurement range
 - DC: 1 μ ADC to 2 ADC
 - AC: 1 μ Arms to 2 Arms
- Compatibility with Hi-Speed USB 2.0 and USBTMC-USB499 standards
- Dual-play – standalone and modular capability
- Bundled software – Keysight Measurement Manager (KMM)
- Wide range of compatible Keysight Development Environments (KDEs)

The Keysight Technologies U2741A is a 5½-digit digital multimeter (DMM), which is the latest addition to the Keysight's USB modular family. It can operate as standalone or as a modular unit when used with the U2781A USB modular product chassis. It comes with various features and functions to meet your needs today.



U2741A used as standalone device

U2741A used as modular device

Various U2741A features to meet your demands

- Affordable and measures up to ten different measurements
- Quick and easy Hi-Speed USB 2.0 connectivity
- Dual-play capability allowing flexible configuration in both simple or sophisticated test environment
- Easy-to-use bundled software to get you started with the DMM without the need to program
- Compatible with a wide range of KDEs
- Portable, accurate and reliable

Value for money and feature rich DMM

The U2741A DMM measures an accurate 5.5 digits resolution complementing a wide range of measurement functions and features. This feature rich DMM has the capability to perform DC voltage, AC voltage, DC current, AC current, 2-wire resistance, 4-wire resistance, continuity, diode, frequency, and temperature measurement to cater various industrial needs.

Data logger function with KMM

The KMM software comes with data logger function which allows data logging customization. Data can be stored for analysis when this option is enabled aside from capturing up to 100 s interval range. With this feature, the U2741A is capable of taking measurement over duration and check for results once the test is completed.

Product Characteristics And General Specifications

Product outlook and dimensions

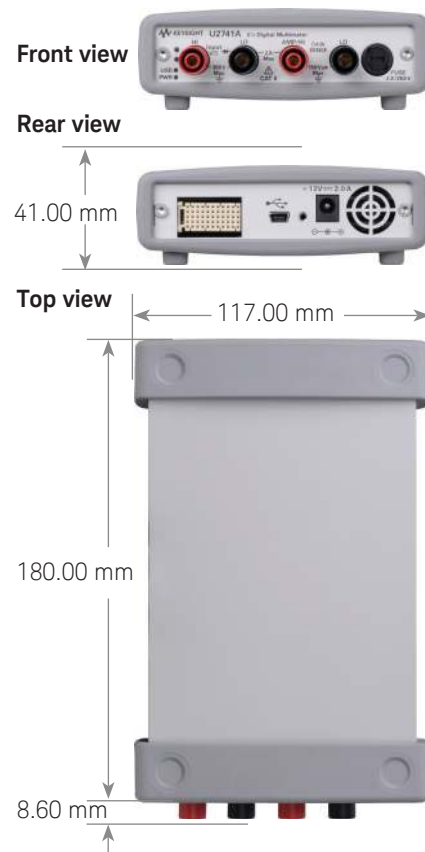

Standard shipped accessories

- 12 V, 2 A AC/DC Power adapter
- Power cord
- Standard test lead set
- USB Standard-A to Mini-B interface cable
- L-Mount kit (used with modular product chassis)
- Keysight USB Modular Products Quick Start Guide
- Keysight Measurement Manager Quick Reference Card
- Keysight USB Modular Products Reference CD-ROM
- Keysight Automation-Ready CD-ROM (contains the Keysight IO Libraries Suite)
- Certificate of Calibration

Optional accessories

- E2308A Thermistor temperature probe
- USB Secure 2-m cable

1. Compatible with Microsoft Windows operating systems only. Requires a direct USB connection to the PC so the appropriate driver can be installed in the USB modular instrument.
2. Applicable for NPLC > 1.
3. Applicable for NPLC 0.2 and 0.02.

Remote Interface

- Hi-Speed USB 2.0*
- USBTMC-USB488¹

Power Consumption

- +12 VDC, 2 A maximum
- Isolated ELV supply source

Operating Environment

- Operating temperature from 18 °C to +28 °C
- Relative humidity at 50% RH (non-condensing)
- Altitude up to 2000 meters
- Pollution Degree 2
- For indoor use only

Storage Compliance

- Storage temperature from -20 °C to 70 °C
- Relative humidity at 5% to 90% RH (non-condensing)

Safety Compliance

Certified with:

- IEC 61010-1:2001/EN 61010-1:2001 (2nd Edition)
- USA: ANSI/UL 61010-1:2004
- Canada: CSA C22.2 No.61010-1:2004

EMC Compliance

- IEC 61326-1:2002/EN 61326-1:1997+A2:2001+A3:2003
- Canada: ICES-001:2004
- Australia/New Zealand: AS/NZS CISPR 11:2004

Measurement Compliance

CAT II 300 V Over-voltage protection

Common Mode Rejection Ratio (CMRR)

- DC CMRR > 120 dB with 1k unbalanced load
- AC CMRR > 70 dB at 50/60 Hz ±0.1% with 1k unbalanced load

Normal Mode Rejection Ratio (NMRR)

- > 60 dB at 50/60 Hz ±0.1%²
- > 0 dB at 50/60 Hz ±0.1%³

Shock and Vibration

Tested to IEC/EN 60068-2

IO Connection

Four banana socket terminals

Dimension (W × D × H)

Module dimension:

- 117.00 mm × 180.00 mm × 41.00 mm (with bumpers)
- 105.00 mm × 175.00 mm × 11.50 mm (without bumpers)

Weight

- 509 g (with bumpers)
- 451 g (without bumpers)

Warranty

One year for U2741A

Three months for standard shipped accessories

Calibration

Calibration interval of one year is highly recommended

Product Specifications

DC specifications ¹

Function	Range	Input impedance	Test current/ Burden voltage, Shunt resistance	Accuracy ±(% of reading + % of range)	Temperature coefficient 0 °C to 18 °C 28 °C to 55 °C
Voltage ²	100.000 mV	10 MΩ	-	0.015 + 0.008	0.002 + 0.0008
	1.00000 V	10 MΩ	-	0.015 + 0.005	0.001 + 0.0005
	10.0000 V	10 MΩ	-	0.018 + 0.005	0.002 + 0.0005
	100.000 V	10 MΩ	-	0.018 + 0.005	0.002 + 0.0005
	300.000 V	10 MΩ	-	0.018 + 0.005	0.002 + 0.0005
Current ³	10.0000 mA	-	< 0.2 V, 10 Ω	0.06 + 0.015	0.005 + 0.0025
	100.000 mA	-	< 0.2 V, 1 Ω	0.06 + 0.005	0.008 + 0.002
	1.0000 A	-	< 0.3 V, 0.1 Ω	0.15 + 0.007	0.005 + 0.002
	2.0000 A	-	< 0.8 V, 0.1 Ω	0.15 + 0.007	0.005 + 0.002
Resistance ⁴	100.000 Ω	-	1.0 mA	0.03 + 0.008	0.006 + 0.0008
	1.00000 kΩ	-	1.0 mA	0.03 + 0.005	0.006 + 0.0005
	10.0000 kΩ	-	100 μA	0.03 + 0.005	0.006 + 0.0005
	100.000 kΩ	-	10.0 μA	0.03 + 0.005	0.006 + 0.0005
	1.00000 MΩ	-	1 μA	0.06 + 0.005	0.01 + 0.0005
	10.0000 MΩ	-	225 nA	0.25 + 0.005	0.025 + 0.0005
	100.000 MΩ	-	225 nA 10 MΩ	2.0 + 0.005	0.3 + 0.0005
Diode test ⁵	1.0000 V	-	1.00 mA	0.015 + 0.03	0.005 + 0.0005
Continuity test ⁶	1.0000 kΩ	-	1.00 mA	0.05 + 0.03	0.005 + 0.0005

NOTE: To ensure better measurement results and to guard against the change of environment or setup, always enable the Null offset.

1. Specifications are based on 30 minutes warm-up time, NPLC 20 resolution, and calibration temperature within 18 °C to 28 °C. For NPLC 0 and 0.025, add 0.01% of range.
2. 120% over range on all ranges except 300 VDC. Input protection up to 300 VDC.
3. Input protected with externally accessible 2 A, 250 V fast blown fuse.
4. Specifications are for 4-wire Ω or 2-wire Ωs using null function in KMM software. If without null function in KMM software, add 0.2 Ω additional error. Input protection up to 300 VDC. Specifications apply for NPLC ≥ 1.
5. Specifications are for the voltage measured at the input terminals only.
6. Continuity threshold is fixed at less than 10 Ω.

AC accuracy for voltage¹

AC specifications

Function	Range	Accuracy input \pm (% of reading + % of range) Frequency (Hz)			
		20 ~ 45	45 ~ 10k	10k ~ 30k	30k ~ 100k ³
Voltage ²	100.000 mVrms	1 + 0.1	0.2 + 0.1	1.5 + 0.3	5.0 + 0.3
	1.00000 V	1 + 0.1	0.2 + 0.1	1.0 + 0.1	3.0 + 0.2
	10.0000 V	1 + 0.1	0.3 + 0.1	1.0 + 0.1	3.0 + 0.2
	100.000 V	1 + 0.1	0.3 + 0.1	1.0 + 0.1	3.0 + 0.2
	250.000 V ⁴	1 + 0.1	0.3 + 0.1	1.0 + 0.1	3.0 + 0.2

Function	Range	Frequency (Hz) (% of reading + % of range)			
		20 ~ 45	45 ~ 10k	10k ~ 30k	30k ~ 100k
Temperature coefficient	100.000 mVrms				
	1.00000 V				
	10.0000 V	0.02 + 0.02	0.02 + 0.02	0.05 + 0.02	0.1 + 0.02
	100.000 V				
	250.000 V				

Function	Range	Burden voltage, Current shunt resistance	Accuracy input \pm (% of reading + % of range) Frequency (Hz)		
			20 ~ 45	45 ~ 1k	1k ~ 10k
Current ⁵	10.0000 mA	< 0.2 V, 10 Ω	1.5 + 0.1	0.5 + 0.1	2 + 0.2
	100.000 mA	< 0.2 V, 1 Ω	1.5 + 0.1	0.5 + 0.1	2 + 0.2
	1.00000 A	< 0.3 V, 0.1 Ω	1.5 + 0.1	0.5 + 0.1	2 + 0.2
	2.00000 A	< 0.8 V, 0.1 Ω	1.5 + 0.1	0.5 + 0.1	2 + 0.2

Function	Range	Accuracy input \pm (% of reading + % of range) Frequency (Hz)		
		20 ~ 45	45 ~ 10k	10k ~ 30k
Temperature coefficient	10.0000 mA			
	100.000 mA	0.02 + 0.02	0.02 + 0.02	0.02 + 0.02
	1.00000 A			
	2.00000 A			

NOTE: To ensure better measurement results and to guard against the change of environment or setup, always enable the Null offset.

- Specifications are based on 30 minutes warm-up time and calibration temperature within 18 °C to 28 °C. In manual range, the settling time is 2.6 seconds while in autorange, the first measurement accuracy is < 1%.
- Specifications are for sine wave inputs more than 5% of range. 120% over range on all ranges except 250 VAC. Maximum crest factor of 5 at full scale. Input impedance is 1 M Ω in parallel with capacitance less than 120 pF, AC couple with up to 300 VDC.
- Additional error to be added as frequency more than 30 kHz and signal input less than 10% of range. 30 kHz to 100 kHz: add 0.003% of range per kHz.
- Input signal has to be more than 50 Vrms.
- Input protected with externally accessible 2 A, 250 V fast blown fuse.

Frequency specifications¹

Frequency accuracy

Function	Range	Accuracy (% of reading + % of range)	Minimum input frequency	Temperature coefficient (% of range)
Frequency	20 Hz to 300 kHz	0.0200 + 0.003	1 Hz	0.005

Frequency Sensitivity for AC Voltage

Function	Range	Minimum sensitivity (RMS sine wave) Frequency (Hz)	
		20 ~ 100k	100k ~ 300k
AC voltage	100 mV ²	20 mV	20 mV
	1 V	100 mV	120 mV
	10 V	1 V	1.2 V
	100 V	10 V	20 V
	250 V	100 V	120 V

Temperature specifications

Temperature specifications

Function	Thermistor type	Range	Accuracy	Temperature coefficient
Temperature	5 kΩ thermistor	-80.0 °C to 150 °C -112 °F to 302 °F	Probe accuracy + 0.2 °C	0.002 °C

NOTE: To ensure better measurement results and to guard against the change of environment or setup, always enable the Null offset.

Typical Reading Speed (in seconds) Characteristics

Test/Range	100 mV(20 Hz)	1V(20 Hz)	10V(20Hz)	100V(45 Hz)	300V(45 Hz)
ACV	0.979	0.979	0.978	0.979	0.979

Test/Range	10 mA	100 mA	1 A	2 A
ACI	0.979	0.979	0.979	0.979

Freq	1.190
------	-------

1. Frequency measurement can only be done in auto range mode. Specifications are for 30 minutes warm-up time, using one second aperture. Measuring method is using reciprocal counting technique with AC coupled input at AC voltage function. Gate time of 0.1 second or 1 second.
2. Only applicable for square wave measurement.

Test	Range/NPLC	20	10	2	1	0.025	0
DCV	100 mV	0.413	0.213	0.053	0.033	0.016	0.016
	1 V	0.414	0.213	0.053	0.033	0.016	0.016
	10 V	0.413	0.213	0.053	0.033	0.016	0.016
	100 V	0.414	0.214	0.053	0.033	0.016	0.016
	300 V	0.413	0.213	0.053	0.033	0.016	0.016
DCI	10 mA	0.413	0.214	0.053	0.033	0.016	0.016
	100 mA	0.393	0.213	0.053	0.033	0.016	0.016
	1 A	0.414	0.213	0.053	0.033	0.016	0.016
	2 A	0.413	0.213	0.053	0.033	0.016	0.016
2W	100 Ω	0.414	0.214	0.053	0.033	0.016	0.016
	1 kΩ	0.414	0.213	0.053	0.033	0.016	0.016
	10 kΩ	0.413	0.214	0.054	0.033	0.016	0.016
	100 kΩ	0.413	0.213	0.053	0.033	0.016	0.016
	1 MΩ	0.413	0.213	0.053	0.033	0.016	0.016
	10 MΩ	0.413	0.213	0.053	0.033	0.016	0.016
	100 MΩ	0.413	0.214	0.053	0.033	0.016	0.016
4W	100 Ω	0.863	0.461	0.141	0.102	0.063	0.062
	1 kΩ	0.830	0.431	0.110	0.069	0.030	0.030
	10 kΩ	0.829	0.430	0.110	0.069	0.030	0.030
	100 kΩ	0.830	0.430	0.110	0.069	0.030	0.030
	1 MΩ	0.831	0.431	0.110	0.070	0.030	0.030
	10 MΩ	0.986	0.585	0.265	0.225	0.186	0.185
	100 MΩ	0.986	0.585	0.265	0.225	0.186	0.186

Test Conditions of PC and USB DMM Module

- Processor: Intel Core 2 Duo Processor E8400 3.00 GHz, 6 MB L2 cache, 1333 MHz FSB
- Memory : 2GB DDR2
- Hard Disk Drive (HDD): 160GB
- Microsoft Windows XP
- Professional Version 2002, Service Pack 2.
- The module is loaded with FW revision 1.12 and running with KMM version is 1.8.7.0

Keysight Measurement Manager

The Keysight Measurement Manager (KMM) is an application data viewer software that comes with the standard purchase of the U2700A Series USB modular instruments. This software is designed to help you perform quick device configuration, data logging and data acquisition using the products.

Supported features found in the U2741A USB Modular Digital Multimeter:

- Command logger
- Self-calibration
- Option to save the current instrument configuration to a file
- Data logging and export feature to CSV, HTML and text only format files that can be printed
- Trigger settings between modules in the instrument chassis with Star trigger and Master/Slave trigger

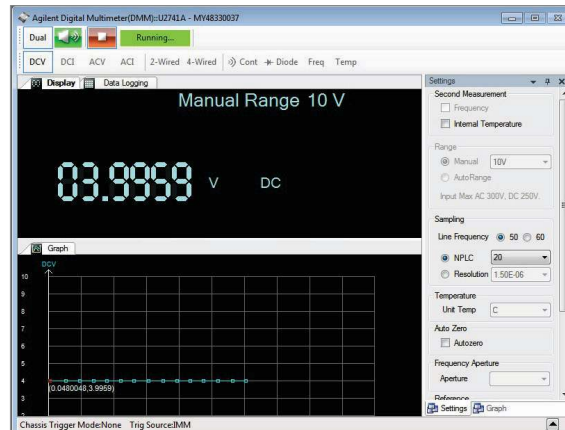

Prior to installing the Keysight Measurement Manager software, ensure that your PC meets the following minimum system requirements for installation and operation.

Requirement	Windows XP operating systems	Windows Vista operating systems	Windows 7 operating systems
Operating system	Windows XP Service Pack 3 (or later) ¹	Windows Vista (32-bit) Service Pack 1 and 2 ²	Windows 7 (32-bit and 64-bit) ^{3,4}
Processor speed	600 MHz or higher required, 800 MHz recommended	1 GHz 32-bit (x86)	3 GHz 32-bit (x86)
Memory	256 MB minimum (1 GB or greater recommended)	1 GB minimum	2 GB minimum
Hard-disk space	1.5 GB minimum	1.5 GB minimum	1.5 GB minimum
Video	Super VGA (800 × 600) 256 colors or more	Support for DirectX® 9 graphics with 128 MB graphics memory recommended ⁵	Support for DirectX 9 graphics with 128 MB graphics memory recommended ⁵
CD-ROM drive or DVD-ROM drive ⁶	Required	Required	Required
Browser	Microsoft Internet Explorer 5.01 or greater	Microsoft Internet Explorer 7 or greater	Microsoft Internet Explorer 7 or greater

1. Supported Windows XP editions – Home or Professional

2. Supported Windows Vista (32-bit) editions – Home Basic, Home Premium, Business, or Ultimate

3. Supported Windows 7 (32-bit and 64-bit) editions – Home Basic, Home Premium, Professional, Enterprise, or Ultimate

4. Keysight Measurement Manger for Windows 7 64-bit support is a 32-bit application running on a WOW64 (Windows-on-Windows 64-bit) emulator.

5. Super VGA graphics is supported for Windows Vista and Windows 7.

6. The type of media provided with the product determines whether a CD-ROM drive or DVD-ROM drive is required.

Software requirements

Keysight IO Libraries Suite 15.1 and above ¹

Keysight T&M Toolkit Runtime version 2.1 ²

Keysight T&M Toolkit Redistributable Package 2.1 patch ²

Microsoft .NET Framework version 2.0 ²

1. Available on the Keysight Automation-Ready CD-ROM

2. Bundled with Keysight Measurement Manager software application installer

Other products in the Keysight USB Modular Test Instruments Family



U2701A/U2702A USB Modular Oscilloscope

Features:

- High sampling rate up to 500 MSa/s, enabling accurate measurement analysis
- Up to 32 MB large memory
- Fast fourier transfer (FFT) and waveform math functions enables easy waveform calculation

For more information: <http://www.keysight.com/find/usbscope>



U2722A/U2723A USB modular source measure unit

Features:

- Three-channel SMU with four-quadrant source/measure operation
- High measurement sensitivity of 100 pA with 16-bit resolution for all voltage and current ranges
- 0.1% basic accuracy
- Embedded test scripts (for U2723A)

For more information: <http://www.keysight.com/find/U2722A>
<http://www.keysight.com/find/U2723A>



U2751A USB modular switch matrix

Features:

- Minimal cross-talk of -30 dB at 45 MHz wide bandwidth
- High bandwidth at 45 MHz without terminal block
- Capability to test up to four devices-under-test (DUTs)
- Works with other Keysight instruments for multi-point testing

For more information: <http://www.keysight.com/find/U2751A>



U2761A USB modular function/arbitrary waveform generator

Features:

- Direct digital synthesis (DDS) waveform generator
- Pulse generator that can generate pulse signal as stimulus
- Easy customization with Arbitrary Waveform Editor
- Internal modulation capability simplifies test setup

For more information: <http://www.keysight.com/find/U2761A>



U2781A USB modular product chassis

Features:

- Expansion of channels for each modular product
- Multiple instrument synchronization
- Internal and external 10 MHz reference clock
- High-speed USB 2.0
- SSI/Star trigger bus synchronization between external trigger source and modules

For more information: <http://www.keysight.com/find/U2781A>

Ordering Information

Model	Description
U2741A	USB modular digital multimeter

Optional accessories

Model	Description
34138A	Test lead set
E2308A	Thermistor temperature probe
U2921A-101	USB secure cable 2 m