

VSO® Low Flow 低流量

Thermally Compensated Proportional Valve 热补偿比例阀



The VSO® Low Flow valve provides enhanced flow control for applications where precise control flow control is required between 0 - 500 sccm. Like the VSO® miniature proportional valve, the VSO® Low Flow miniature proportional valve provides precise flow control of gas in proportion to input current. The valve can be controlled with either DC current or pulse width modulation along with closed loop feedback to deliver optimal system performance. Together with its ability to provide precise control over a wide range of media, the VSO® Low Flow miniature proportional valve is ideally suited for manufacturers of Gas Chromatography and Mass Spectrometry equipment.

Features

Typical Applications 典型应用

- Gas Chromatography
- Mass Spectrometry
- Pressure & Flow Control
- Mass Flow Control
- 色谱、质谱、质量流量压力控制

- Enables precise low flow (0 - 500 sccm) control for improved instrument accuracy
- Thermally compensated to maintain precise flow over a wide range of media
- Computer automated calibration and serialization for performance traceability
- Cleaned for Oxygen and Analytical Service use
- Proven performance tested to 10 million life cycles
- RoHS compliant 

Product Specifications

Physical Properties

Valve Type:	2-Way Normally Closed
Media:	Air, argon, helium, hydrogen, methane, nitrogen, oxygen, & others
Operating Environment:	32 to 131°F (0 to 55°C)
Storage Temperature:	-40 to 158°F (-40 to 70°C)
Length:	1.79 in (45.3 mm)
Width:	0.63 in (15.9 mm)
Height:	0.67 in (17.0 mm)
Porting:	Manifold mount
Weight:	2.2 oz (63 grams)

Physical Properties

Internal Volume:	0.031 in ³ (0.508 cm ³)
Filtration:	5 Micron (Customer Supplied)
Flow Direction:	Inlet Port Port 2 Outlet Port Port 1
Oxygen and Analytically Clean:	Standard

Electrical

Power:	2.0 Watts maximum
Voltage:	See Table 2
Electrical Termination:	18" (45.7 cm) Wire Leads

Wetted Materials

Body:	360 HO2 Brass
Stem Base:	430 FR Stainless Steel and Brass 360 HT
All Others:	FKM; 430 FR Stainless Steel; 300 Series Stainless Steel

Performance Characteristics

Leak Rate:	The leakage shall not exceed the following values: Internal 0.2 SCCM of He with a differential pressure of 1 psid, 25 psid and 150 psid External 0.016 SCCM of He at 150 psi
Pressure:	0 to 150 psi (10.34 bar) See Table 1
Vacuum:	0-27 in Hg (0-686 mm Hg)
Orifice Size:	0.003" (0.076 mm)
Hysteresis:	7% of full scale current (Typical) 15% of full scale current (Max)

VSO is a registered trademark of Parker Hannifin Corporation.



VSO® Low Flow Thermally Compensated Proportional Valve

Typical Flow Curve

Typical Air Flow with 13.5 VDC Coil @ 25 psid (1.7 bar)

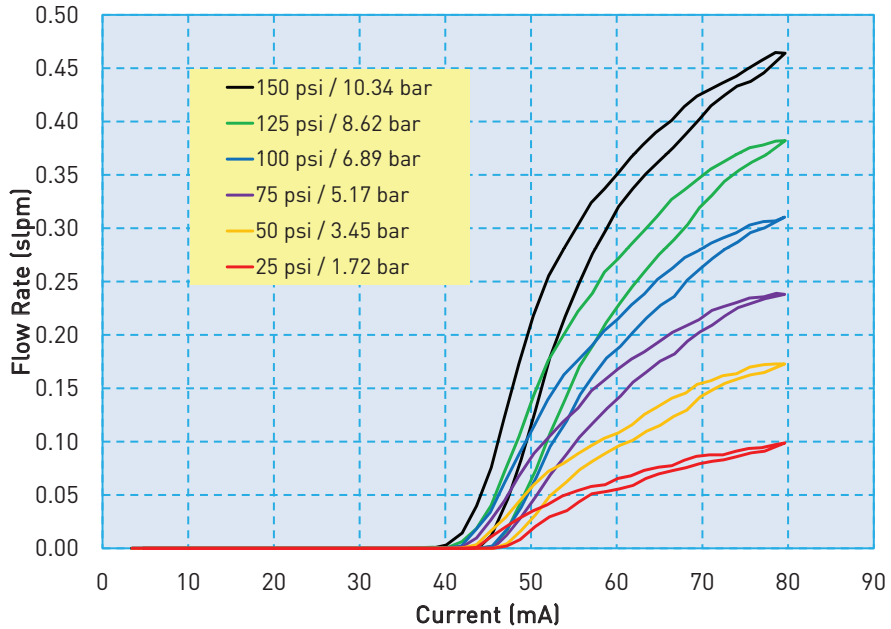

Model L3 - 0.003" (0.076 mm) Orifice
Pressure vs Flow Curve

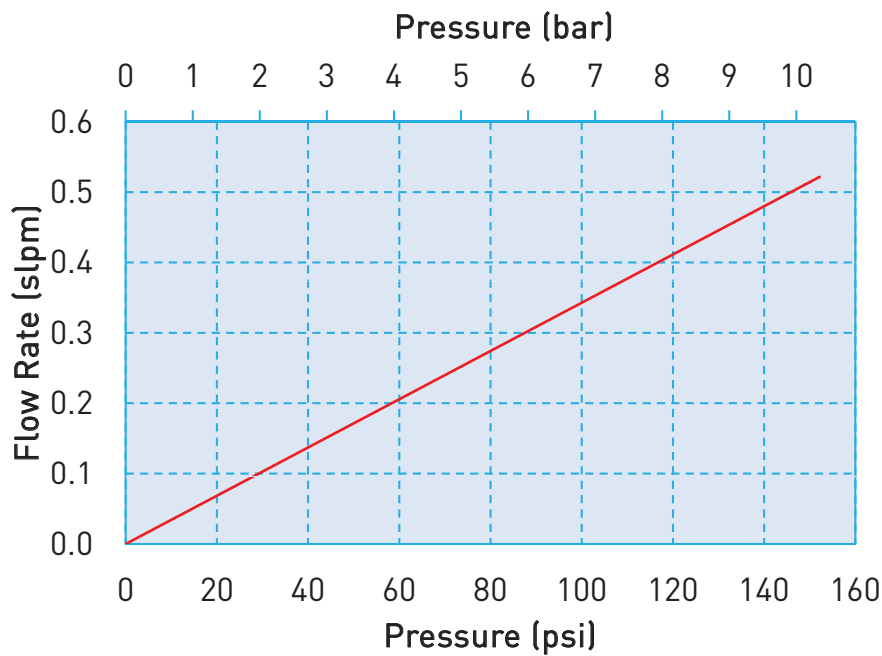

Pressure and Flow Capabilities

Table 1

Orifice Diameter	Maximum Operating Inlet Pressure	Maximum Operating Pressure Differential
0.003 in (0.076 mm)	150 psig (10.34 bar)	150 psid (10.34 bar)



VSO[®] Low Flow Thermally Compensated Proportional Valve

Pneumatic Interface

VSO[®] Low Flow Manifold Mount



Mechanical Integration

Dimensions

VSO[®] Low Flow Basic Valve Dimensions

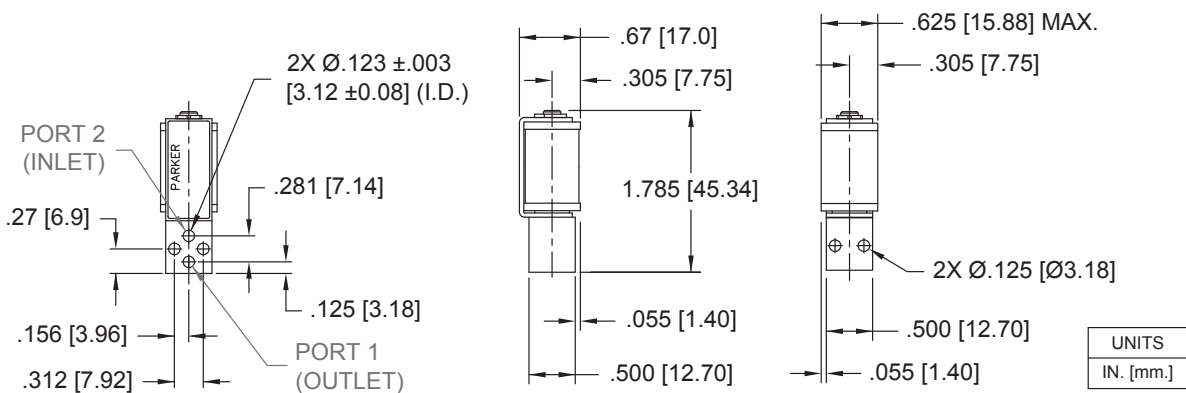

Electrical Interface

Coil Type: 18" Wire Lead

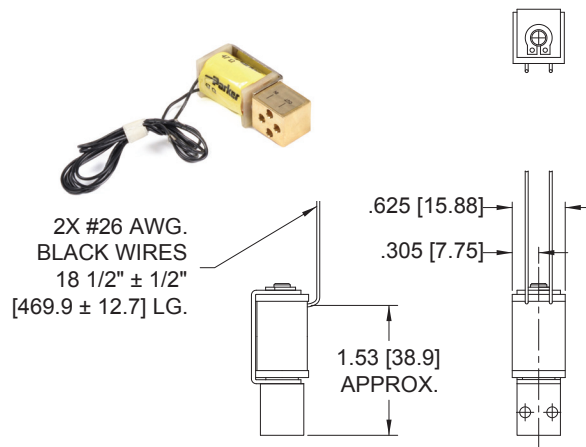

Electrical Requirements

Table 2

Minimum Available Voltage (VDC)	Nominal Coil Resistance @ 20 °C (Ohms)	Input Current for Full Flow (mA)
6.5	47	130
8.0	68	115
12	136	80
18	274	60
24.0	547	43



VSO[®] Low Flow Thermally Compensated Proportional Valve

Installation and Use

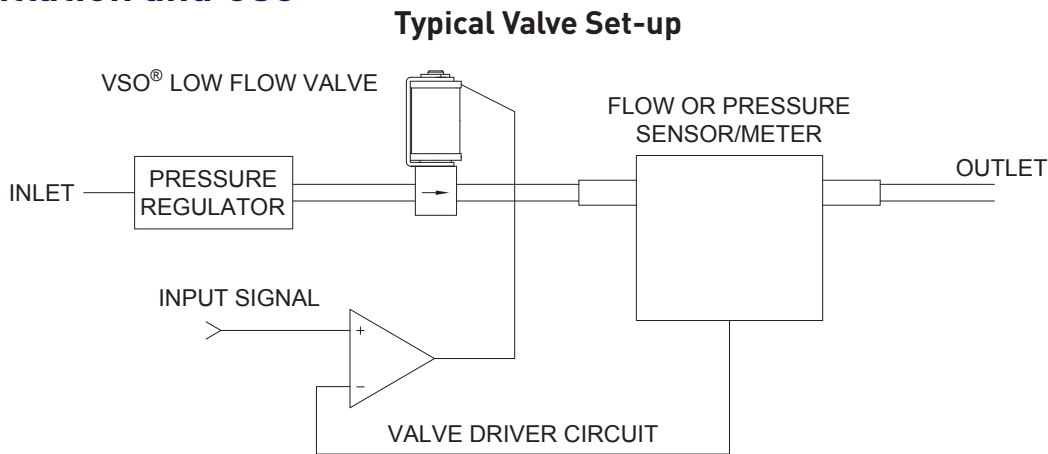

Valve Electrical Control

Basic Control:

The VSO[®] Low Flow valve can be controlled by either voltage or current; however, it is highly recommended that current control be employed to ensure the most repeatable valve flow performance.

PWM Control:

For PWM control, the signal applied to the valve should have a frequency between 5-12kHz. Optimum frequency will be application dependent.

Suggested VSO[®] Low Flow Current Driver Schematic

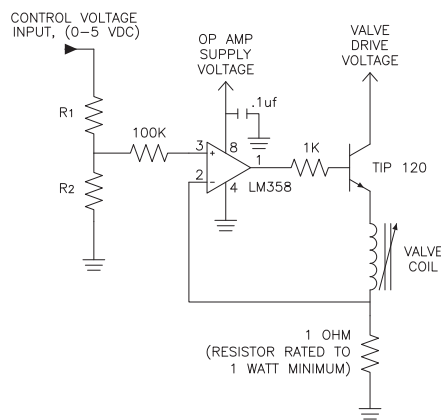

This simple current driver circuit draws only 1 mA at the input control (0-5VDC) and provides control for any VSO[®] Low Flow configuration regardless of valve voltage or resistance.

Table 3 (below) describes the recommended R1 and R2 resistor values based upon the full shut-off current.

Table 3: Selectable Resistor Values for a Low Current (1mA) LM358-Based Current Driver

Voltage Supplied to Valve Coil (Reference)	Valve Drive Voltage (VDC)	Nominal Coil Resistance @ 20°C (Ohms)	Input Current for Full Flow (mA)	R1 (Ohms)	R2 (Ohms)
6.5	8.5	47	130	4990	102
8.0	10.0	68	115	4990	73
12.0	14.0	136	80	5100	34.4
18.0	20.0	274	60	8560	28.7
24.0	26.0	547	43	8560	15.4

VSO® Low Flow Thermally Compensated Proportional Valve Installation and Use

Manifold & O-Ring Dimensions & Design

Not shipped with valves.

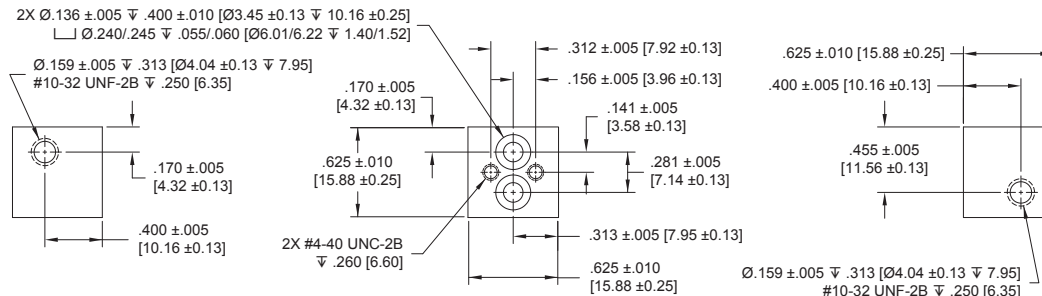

Accessories

O-Ring (Manifold Seal) Dimensions
190-007024-002 (2 required for each valve)

I.D. = Ø.114 ±.005 [Ø2.90 ±0.13]
W = .070 ±.003 [1.78 ±0.08]
O.D. = Ø.254 [Ø6.45] REFERENCE

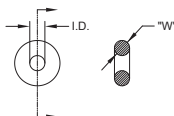

Screw 4-40 x 5/8" Pan Head, Phillips
191-000115-010 (2 required for each valve)



Ordering Information

Sample Part ID	910	-	000200	-	001
Description	Series	-	Model Number:	-	Coil Voltage*
Options			VSO Low Flow, 0.003" (0.076 mm) Orifice		001: 6.5 VDC 002: 8 VDC 003: 12 VDC 004: 18 VDC 007: 24 VDC * Maximum voltage for continuous full flow, ambient temperature 55°C

Accessories					
190-007024-002: O-ring, FKM, 0.114" ID x 0.070" Thick*	* Not supplied with the valve. Used as a seal between the valve body and manifold.				
191-000115-010: Screw 4-40 x 5/8" Pan Head **	**Not supplied with the valve. Used to mount the valve to a manifold.				

NOTE: In order to provide the best possible solution for your application, please provide the following requirements when contacting Applications Engineering:

- Media, Inlet & Outlet Pressures
- Minimum Required Flow Rate
- System Supply Voltage
- Media & Ambient Temperature Range

Please click on the Order On-line button (or go to www.parker.com/precisionfluidics/lowflow) to configure your VSO® Low Flow Thermally Compensated Proportional Valve. For more detailed information, visit us on the Web, or call and refer to Performance Spec. #790-002160-002 and Drawing #890-003022-022.

PPF-MPV-002/US August 2013

电话联系中国代理 北京品超思瑞科技有限公司010-63150800

pcm@pcsr-tech.com

Visit www.pcsr-tech.com

