

BL Series

Liquid Level Sensor

Liquid Level Sensor For Mounting Pipe (Through-Beam)

■ Features

- Detects liquid in a transparent/semitransparent pipe diameter $\varnothing 6$ to 13mm, thickness 1mm
- Compact size: W23×H14×L13mm
- Selectable Light ON/Dark ON operation mode by operation mode switching button
- Easy to check operation status by operation mode indicator [green LED (Light ON: ON, Dark ON: OFF)], operation indicator [red LED]
- Built-in reverse polarity and output short-circuit protection circuits
- IP64 of protection structure (IEC standards)



⚠ Please read "Caution for your safety" in operation manual before using.



■ Model

Model	Pipe diameter	Sensing type	Power supply	Control output
BL13-TDT	$\varnothing 6$ to 13mm	Through-beam	12-24VDC $\pm 10\%$	NPN open collector output
BL13-TDT-P				PNP open collector output

■ Specifications

Model	NPN output	BL13-TDT
	PNP output	BL13-TDT-P
Sensing type	Through-beam	
Applicable pipe	$\varnothing 6$ to 13mm (thickness: 1mm) transparent pipe (FEP (fluoroplastic) or with equivalent transparency)	
Standard sensing target	Liquid in a pipe※1	
Response time	Max. 2ms	
Power supply	12-24VDC $\pm 10\%$ (Ripple P-P: Max. 10%)	
Current consumption	Max. 30mA	
Light source	Infrared LED (950nm)	
Operation mode	Light ON/Dark ON switching by operation mode switching button	
Control output	NPN or PNP open collector output ●Load voltage: Max. 30VDC ●Load current: Max. 100mA ●Residual voltage: Max. 1V	
Protection circuit	Reverse polarity protection circuit, output short-circuit protection circuit	
Indicator	Operation indicator: Red LED, Operation mode indicator: Green LED	
Insulation resistance	Min. 20M Ω (at 500VDC megger)	
Noise resistance	$\pm 240V$ the square wave noise (pulse width: 1 μs) by the noise simulator	
Dielectric strength	1,000VAC 50/60Hz for 1 minute (between all terminals and case)	
Vibration	1.5mm amplitude or 300m/s ² at frequency of 10 to 55Hz in each of X, Y, Z direction for 2 hours	
Shock	500m/s ² (approx. 50G) in each X, Y, Z direction for 3 times	
Environment	Ambient illumination	Sunlight/Incandescent lamp: Max. 3,000lx for each (Receiver illumination)
	Ambient temperature	10 to 55°C, storage: -25 to 65°C
	Ambient humidity	35 to 85%RH, storage: 35 to 85%RH
Protection structure	IP64 (IEC standards)	
Material	Case: PC	
Cable	$\varnothing 2.5$, 3-wire, Length: 1m (AWG28, Core diameter: 0.08mm, Number of cores: 19, Insulator diameter: $\varnothing 0.9$)	
Accessory	Binding band 2EA, Anti-slip tube 2EA	
Approval	CE	
Unit weight	Approx. 30g	

※1: This may not detect the liquid with low transparent, with high viscosity, or with floating matters.

※The temperature or humidity mentioned in Environment indicates a non freezing or condensation environment.

(A) Photoelectric Sensors

(B) Fiber Optic Sensors

(C) Door/Area Sensors

(D) Proximity Sensors

(E) Pressure Sensors

(F) Rotary Encoders

(G) Connectors/ Sockets

(H) Temperature Controllers

(I) SSRs / Power Controllers

(J) Counters

(K) Timers

(L) Panel Meters

(M) Tacho / Speed / Pulse Meters

(N) Display Units

(O) Sensor Controllers

(P) Switching Mode Power Supplies

(Q) Stepper Motors & Drivers & Controllers

(R) Graphic/ Logic Panels

(S) Field Network Devices

(T) Software

BL Series

Operation Mode

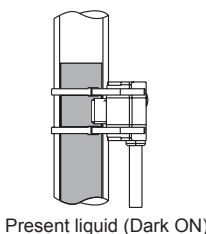
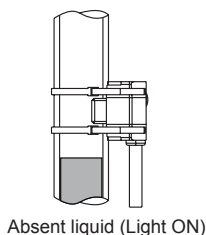

Operation mode	Light ON	
Receiver operation	Received light	
	Interrupted light	
Operation indicator (red LED)	ON	
	OFF	
Transistor output	ON	
	OFF	

Operation mode	Dark ON	
Receiver operation	Received light	
	Interrupted light	
Operation indicator (red LED)	ON	
	OFF	
Transistor output	ON	
	OFF	

Operating Timing Diagram

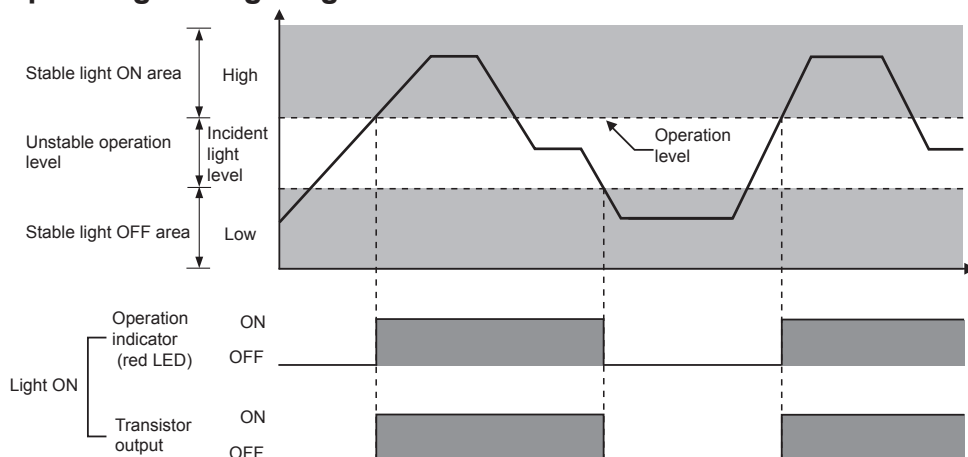

※The waveforms of 'Operation indicator' and 'Transistor output' are for Light ON, it is operated as reverse in Dark ON.

Control Output Circuit Diagram

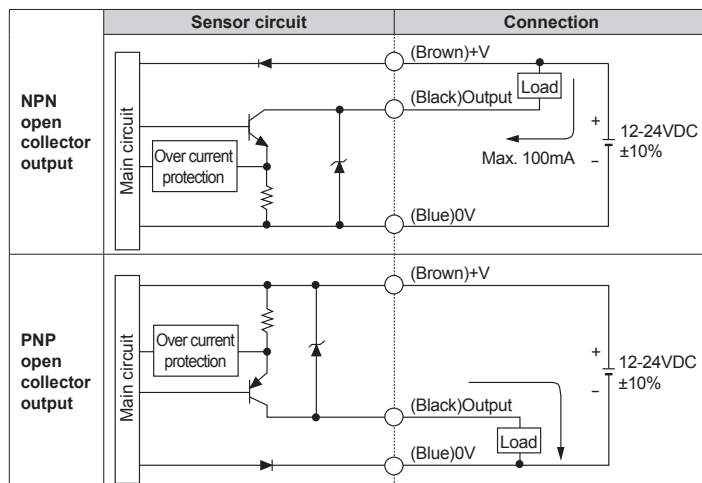

Connection

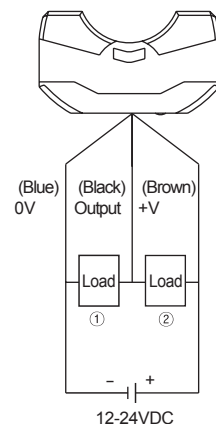

- ① Load connection for PNP output
- ② Load connection for NPN output

Liquid Level Sensor

Dimensions

(unit: mm)

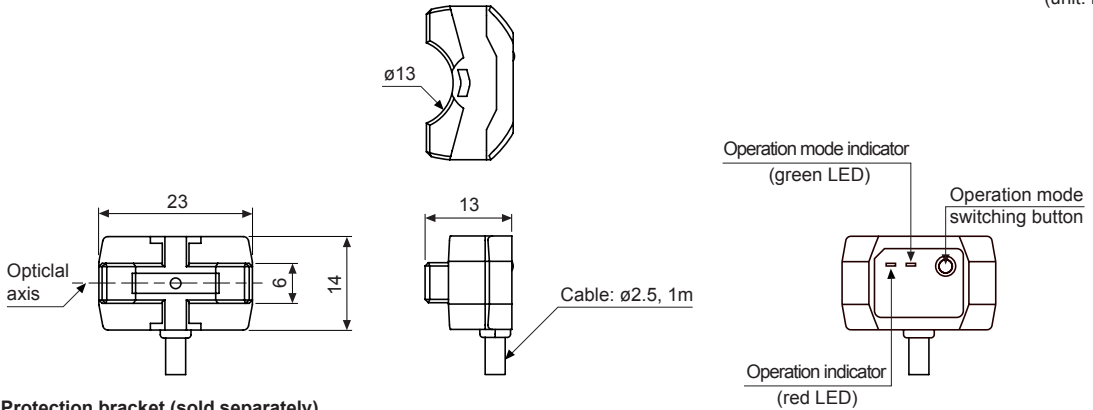

Protection bracket (sold separately)

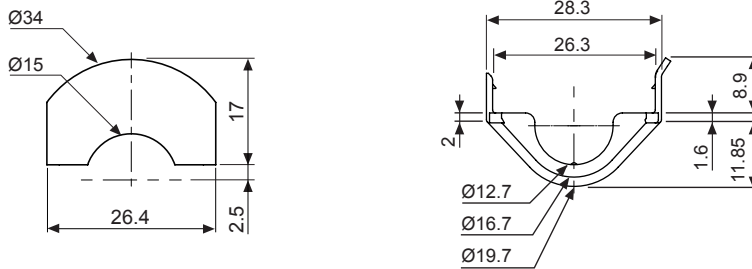

※For using the protection bracket, only $\varnothing 12.7\text{mm}$ (1/2 inch) pipes are available.

Installation

If installing this unit at opaque pipes, it is impossible to detect accurately. Install this unit at the rated pipes.
Using binding band: $\varnothing 6$ to 13mm, Using protection bracket: $\varnothing 12.7\text{mm}$ (1/2 inch)

- If installing this unit at an opaque pipe, it is impossible to detect accurately. Install this unit at the rated pipe.
- Fix a pipe and this sensor tightly with binding bands and anti-slip tubes as the below figure and cut the spare part of binding bands with scissors or a knife.
- When connecting binding bands, be careful not to transform a pipe.

Protection bracket (sold separately)

Choose a location on the pipe and attach the sensor and the protection bracket.

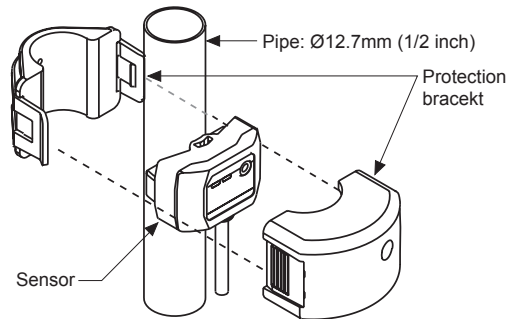
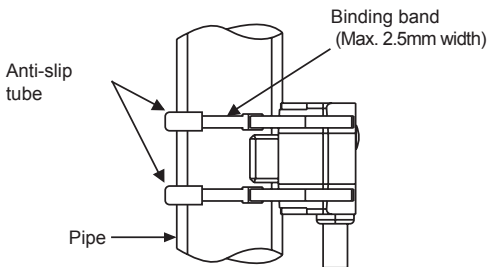

Principle of operation

It detects whether there is liquid or not in a pipe by refractive index of light.

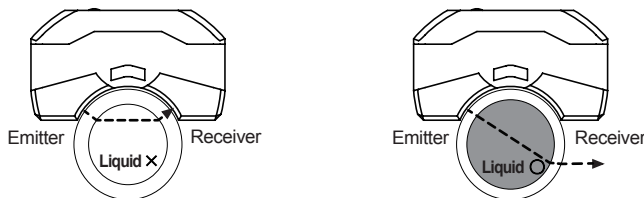

(A) Photoelectric Sensors

(B) Fiber Optic Sensors

(C) Door/Area Sensors

(D) Proximity Sensors

(E) Pressure Sensors

(F) Rotary Encoders

(G) Connectors/ Sockets

(H) Temperature Controllers

(I) SSRs / Power Controllers

(J) Counters

(K) Timers

(L) Panel Meters

(M) Tacho / Speed / Pulse Meters

(N) Display Units

(O) Sensor Controllers

(P) Switching Mode Power Supplies

(Q) Stepper Motors & Drivers & Controllers

(R) Graphic/ Logic Panels

(S) Field Network Devices

(T) Software

BL Series

■ Functions

● Operation mode switching

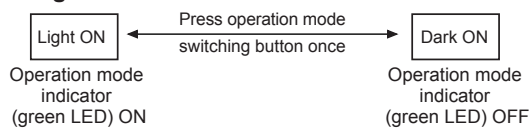
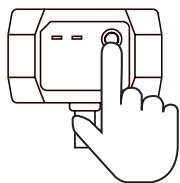

● Operation mode lock setting

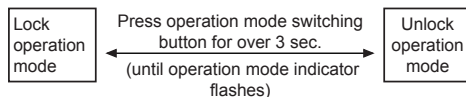
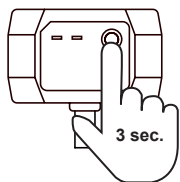

※If you press the operation mode switching button (less than 3 sec.) in lock operation status and the operation mode indicator (green LED) flashes 3 times.