



Viscotester VT-06



Uni-Cylinder Rotational Viscotester Allows Easy Measurement of Fluid Viscosity



The VT-06 is designed for quality control applications in the manufacturing process of industrial products such as petrochemicals, paint, and adhesives, as well as foodstuffs. Viscosity measurements covering a wide range are possible, such as gear oil used in construction machinery. Measurement is performed by simply submerging a rotor in the fluid. The resistance to rotor movement caused by the viscosity (torque) is measured to obtain direct readings.

- Compact and light weight make the unit easily portable and allow operation with one hand
- Can be powered by alkaline batteries, nickel-hydride rechargeable batteries, or AC adapter
- Direct indication of viscosity in millipascal-seconds or decipascal-seconds (SI units)
- Dedicated stand for measurement available as option

[Usage]

1. Attach rotor to unit and hold unit in the hand or place on dedicated stand. (Unit should be approximately horizontal in either case.)
2. Insert rotor in sample fluid, turn power on, and select rotor number.
3. Press start button and read indicated viscosity.

*The supplied extension rod can reach fluid that is further away. (Only for use with the No.1 and No.2 rotors.)

Specifications

Measurement range	No. 3 rotor: 0.3 to 13 dPa·s (with No. 3 cup) No. 1 rotor: 3 to 150 dPa·s (with JIS 300 mL beaker*1) No. 2 rotor: 100 to 4000 dPa·s (with JIS 300 mL beaker*1)
Sample fluid capacity	No. 1 and No. 2 rotor (with JIS 300 mL beaker*1) approx. 300 mL No. 3 rotor (with No. 3 cup) approx. 150 mL Clearance between rotor end and cup bottom: about 15 mm
Measurement accuracy	±10 % ±1 digit of indicated value, reproducibility ±5 %
Rotor speed	62.5 rpm
Power supply	IEC LR6 (size AA) alkaline batteries, nickel-hydride rechargeable batteries, AC adapter VA-05J

Dimensions and Weight	175 (H) × 77 (W) × 40 (D) mm (without protruding parts), Approx. 260 g (without batteries)		
Supplied accessories	No. 1 rotor (dia. 24 × 53 mm)	SUS304	1
	No. 2 rotor (dia. 15 × 1 × 113 mm)	SUS304	1
	No. 3 rotor (dia. 45 × 47 × 160 mm)	SUS304	1
	No. 3 Cup (dia. 52.6 × 75 mm)	SUS304	1
	Extension rod (900 mm · 300×3)	SUS304	1
	IEC LR6 (size AA) alkaline batteries		4

*1 JIS R 3503 : 1994, φ78×103 (H)

Options

Product name	Product number
Stand	VA-04
AC adapter	VA-05J

Rotors and Cups (unit: mm)

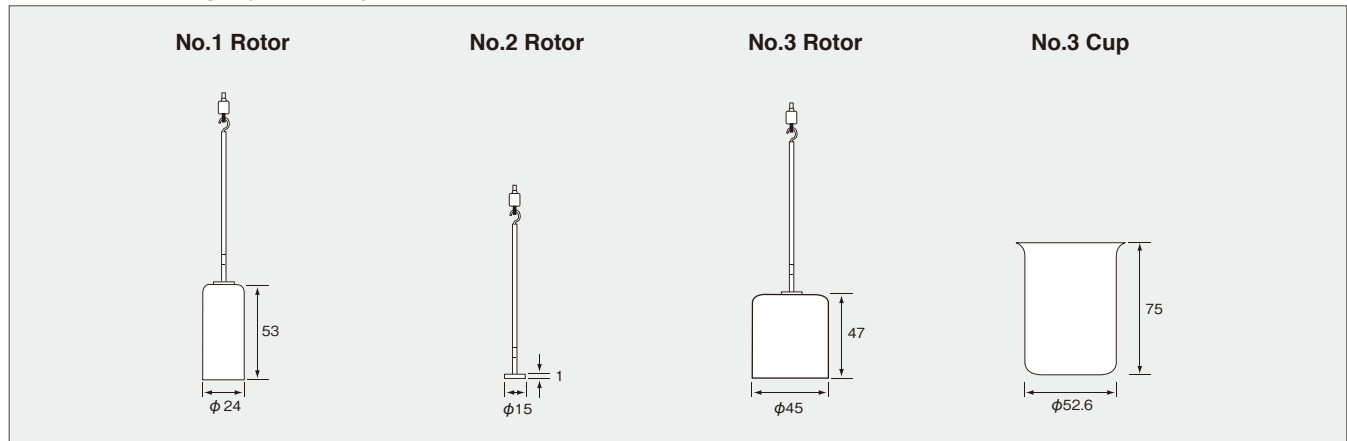

Sample amount for measurement

No.3 Cup	approx.150 mL
Commercially available 300 mL beaker	approx.350 mL

Note: For certain fluids, readings may differ slightly from other viscometers, depending on properties of target fluids, mechanical factors, as well as specific gravity, rotor speed, and other aspects.

Viscotester measurement examples (for reference)

Product type	Viscosity	Rotor
Newtonian fluids		
Castor oil	6 dPa·s	No.3
Starch syrup	1 000 dPa·s	No.2
Non-Newtonian fluids		
Condensed milk	16 dPa·s	No.1
Chocolate syrup	25 dPa·s	No.1
Tomato ketchup	43 dPa·s	No.1
Pure honey	76 dPa·s	No.1
Toothpaste	320 dPa·s	No.2
Starch paste	310 dPa·s	No.2

* Measurement temperature: 23 °C

CGS Unit and SI Unit

$$1\text{cP} = \frac{1}{1,000} \text{Pa}\cdot\text{s} = 0.01 \text{dPa}\cdot\text{s} \quad 1\text{P} = \frac{1}{10} \text{Pa}\cdot\text{s} = 1 \text{dPa}\cdot\text{s}$$

P(poise), cP(centi poise), Pa·s(pascal-seconds), dPa·s(decipascal-seconds)

* Specifications subject to change without notice.

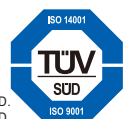

ISO 14001 RION CO., LTD.
ISO 9001 RION CO., LTD.



This product is environment-friendly. It does not include toxic chemicals on our policy.
This leaflet is printed with environmentally NON-VOC ink on recycled paper.