

# Operation Manual

## Series *LMIX1*

Magnetic Incremental Length Measuring System with 0.1 mm resolution



- Sensor with external translator
- Direct contact free measurement
- The distance between sensor and magnetic tape can be between 0.1 and 2.0 mm
- High resolution of 0.1 mm (0.025 mm at 4 edge triggering)
- Repeat accuracy +/- 1 increment
- Insensitive against dirt

## Content

<b>1.</b>	<b>General Information .....</b>	<b>3</b>
1.1	Information Operation Manual .....	3
1.2	Explanation of Symbols.....	3
1.3	Statement of Warranties .....	4
1.4	Demounting and Disposal .....	5
<b>2</b>	<b>Safety .....</b>	<b>6</b>
2.1	General Cause of Risks .....	6
2.2	Personal Protective Equipment.....	6
2.3	Conventional Use .....	7
<b>3</b>	<b>Transport and Storage .....</b>	<b>7</b>
3.1	Safety Instructions for Transport / Unpacking and Loading.....	7
3.2	Handling of Packaging Material .....	7
3.3	Check of Transport .....	8
3.4	Storage .....	8
<b>4</b>	<b>Product Features .....</b>	<b>9</b>
<b>5</b>	<b>Technical specifications .....</b>	<b>10</b>
5.1	Dimensions LMIX1 .....	11
<b>6</b>	<b>Installation/ Initial start-up.....</b>	<b>12</b>
6.1	Mounting of the Sensor .....	12
6.2	Pin assignment D-SUB.....	12
<b>7</b>	<b>Options .....</b>	<b>13</b>
7.1	Structure of Magnetic tape MB20-50-10-1-R .....	13
7.2	Handling.....	13
7.3	Processing instructions for the adjustment of magnetic tapes .....	14
7.4	Resistance against chemical influences .....	14
7.3	Sticking and Cutting.....	15
<b>8</b>	<b>Interferences.....</b>	<b>16</b>
8.1	Security.....	16
8.2	Electrical interference suppression .....	17
8.3	Restart after fault clearance.....	17
8.4	EMC information .....	18
<b>9.</b>	<b>Maintenance.....</b>	<b>18</b>
<b>10.</b>	<b>Type Designation LMIX1 .....</b>	<b>19</b>
<b>11.</b>	<b>Index.....</b>	<b>20</b>

## 1. General Information

### 1.1 Information Operation Manual

The manual contains important information regarding the handling of the sensor. Precondition for safe operation is the compliance with the specified safety and handling instructions. Moreover, observe the existing local accident prevention regulation and general safety rules.

Please read the operation manual carefully before starting to work. The manual should be kept accessible at anytime. The illustrations in the manual are for better representation of the facts they are not necessarily to scale and can be slightly different to the actual construction

### 1.2 Explanation of Symbols

#### Warning notices

Warning notices are characterised by symbols in the operation manual. The notes will be introduced by signal words to express the magnitude of the danger.

Follow these advices in order to avoid accidents and injuries to persons and property.



#### **DANGER!**

... adverts to direct dangerous situations that can lead to death or severe injuries.



#### **CAUTION!**

... advices to potentially dangerous situations that can lead to death or severe injuries.



#### **ATTENTION!**

... advices to potentially dangerous situations that can lead to damages on property.

## Hints and Commendations

**ADVERT!**

...highlights helpful hints and recommendations for efficient and failure-free operation.

## Specific Safety Instructions

The following symbols in conjunction with safety instructions are used in order to point out possible hazards:

**DANGER!**

...marks perilous situations by electricity. By non-observance of the safety instructions the possibility of death or severe injuries exists. The operations have to be carried out only by an electrician.

## 1.3 Statement of Warranties

The warranty conditions are in a separate document.

### Guarantee

The producer guarantees the functional capability of the process engineering and the selected parameter. The period of warranty is one year and begins with the date of delivery.

## 1.4 Demounting and Disposal

Unless otherwise authorized, dispose the item considering the safety instructions.

### Before demounting

- Disconnect the power supply
- Secure against re-start
- Disconnect supply lines physically and discharge remaining energy
- Dispose operating supplies with respect to the environment

### Disposal

Recycle the decomposed elements:

- Scrap metal elements
- Recycle plastic parts
- Dispose the rest of the components according to their material consistence



#### **ATTENTION!**

Wrong disposal → damage caused to the environment!

Electronic waste, electronic components, lubricants and operating supplies are liable to treatment of hazardous waste.

Only approved specialized companies should perform disposal.

Local authorities and waste management facilities provide information about environmentally suitable disposal.

## 2 Safety

### 2.1 General Cause of Risks

This chapter gives an overview about all important safety aspects to guarantee an optimal protection of employees.

Non-observance of the instructions mentioned in this operation manual can result in hazardous situations.

### 2.2 Personal Protective Equipment

Employees should wear protective clothing during installation of the device to minimize the risk of accidents.

Therefore:

Change into protective clothing before beginning the work process. Also observe any labels in the operating area regarding protective clothing.

#### Protective clothing



#### Safety working clothing

- ... is close-fitting
- ... is tear proof
- ... has tight sleeves without distant parts

Also wear no rings, necklaces or other jewellery.



#### Protective gloves

- ... for protecting the hands against abrasion and cuts

## 2.3 Conventional Use

The ELGO **LMIX1** length measuring system is for the limited purpose as described in this manual:

The **LMIX1** length measuring system is constructed for measuring a distance up to 32 meter.



### CAUTION!

Danger through non conventional use!

Non-intended use and non-observance of this operation manual can lead to dangerous situations.

Therefore:

- Use **LMIX1** only as described.
- Strictly follow this manual.

Avoid in particular:

Remodelling, refitting or changing of the device or parts of it with the intention to alter functionality or scope of the **LMIX1**.

ELGO is not liable for any damages resulting from improper use of the product.

## 3 Transport and Storage

### 3.1 Safety Instructions for Transport / Unpacking and Loading



### ATTENTION!

Professional transport only.  
Do not throw, hit or fold the package.

### 3.2 Handling of Packaging Material

Adverts for proper disposal refer to 1.4.

### 3.3 Check of Transport

Examine delivery immediately after receiving for completeness and transport damages.

In case of externally recognizable transport damages:

- Do not accept the delivery or do accept under reserve
- Note extent of damages on the transportation documents or on the delivery note
- File complaint immediately

**ADVERT!**

Claim any damages you recognize as soon as possible. The claims for damage must be filed in the lawful reclaim periods.

### 3.4 Storage

Store device only under following conditions:

- Do not store outside
- Keep dry and dust free
- Do not expose to aggressive media
- Protect from direct sun light
- Avoid mechanical shocks
- Storage temperature: -20 to +70 °C
- Relative humidity: max. 80%
- Inspect packages regularly if stored for an extensive period of time (> 3 months)



## 4 Product Features

The *LMIX1* is an incremental magnetic length measuring system. The sensor technology and translator are placed in two different housings (Sensor in sensor head and translation unit in external Sub-D connector). The magnetic tape of the series MB2020 can also be fixed into a guiding rail with the provided sticky tape. The *LMIX1* can be installed up to a maximum distance of 2.0 mm.

The incremental measuring system offers decisive advantages:

- With reference pulse
- Direct contactless measurement
- The distance between sensor and measuring tape can vary between 0.1 and 2.0 mm
- Measuring length theoretical unlimited
- High resolution of 0.1 mm (0.025 mm at 4 edge triggering)
- Repeating accuracy +/- 0.1 mm
- Very robust against pollution

Typical applications are handling systems, conveyor and storage technology, hydraulic presses, stamping machines, casting machines, linear slides, linear drives and pick and place systems.

## 5 Technical specifications

LMIX1	
Power supply	10... 30 VDC / 5VDC
Consumption	10... 30 VDC: max. 150mA / 5 VDC: 200 mA
Signal	10... 30 V HTL / 5V TTL
Resolution	0.1 mm (0.025 mm at 4 edge triggering)
Repeating Accuracy	+/- 0.1 mm
Maximum operation speed	4 m/s
Signal Outputs	A, A', B, B', Z, Z'
Measuring length	theoretical unlimited
Distance Sensor/tape	Max. 2.0 mm
System Accuracy in $\mu\text{m}$ at 20°C	+/- 10 +20 x L (L= Measuring length in meter)
Operation temperature	0°... +60°C (higher on request)
Storage temperature	-20°... +70°C
Humidity	Non condensing, max. 80%
Protection class	IP67
mechanical Data Sensor	LMIX1-Housing: 25 x 10 x 15 mm
Cable	Drag chain suitable, length max. 30.0 m, weight: ca. 58.0 g/m, wires: 2 x 0.75 mm <sup>2</sup> und 6 x 0.14 mm <sup>2</sup> bending radius: min. 60 mm
Magnetic tape MB20-50-10-1-R	coefficient of extension @ = $16 \times 10^{-6} \text{K}^{-1}$ Linear extension $\Delta L = L \times @ \times \Delta @$ 10mm x ca. 1.8mm (W x H) min. bending radius 150mm

## 5.1 Dimensions LMIX1

side view

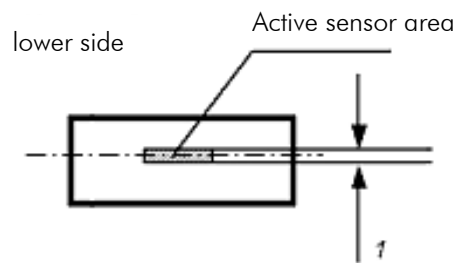
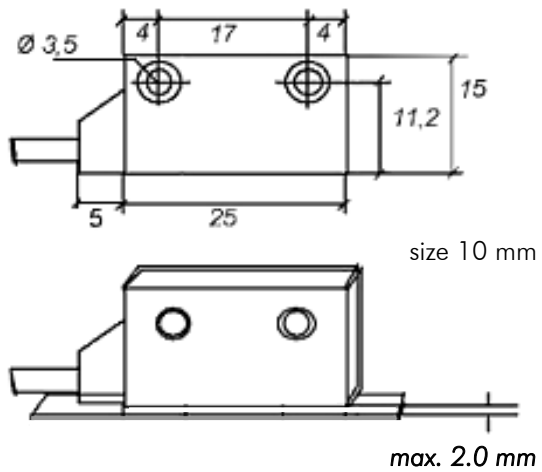

## 6 Installation/ Initial start-up

### 6.1 Mounting of the Sensor

Tolerances for distance and angle must be observed.

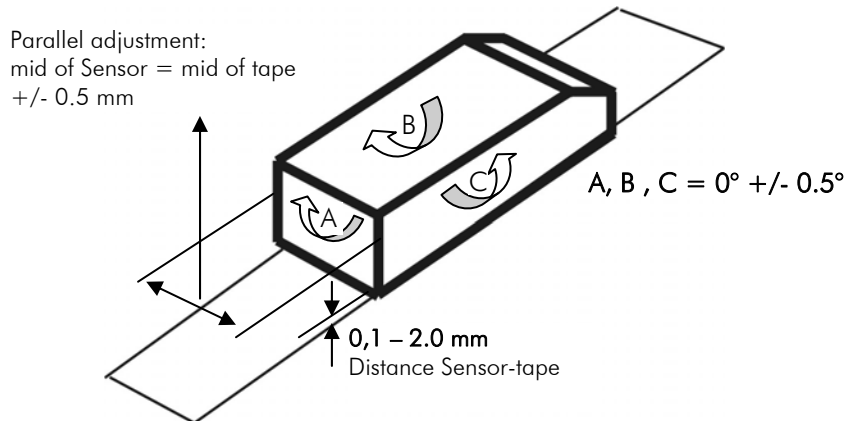

### 6.2 Pin assignment D-SUB

Only version 5 V / 5 V-TTL order index 11  
and 10-30 V / 5 V-TTL order index 01

Pin	Function
1	0 VDC
2	+ 5V resp. 10-30 VDC
3	A
4	B
6	A'
7	B'
8	-
9	-

Only version 10-30 V / 10-30 V-HTL  
order index 00

Pin	Function
1	0 VDC
2	+ 10-30 VDC
3	A
4	B
6	-
7	-
8	Z
9	Z'

## 7 Options

### 7.1 Structure of Magnetic tape **MB20-50-10-1-R**

The tape consists of 3 components (see Figure 1), a magnetized, flexible plastic tape (Item 3), which is connected with a steel band (Item 5) and a cover tape (item 1), which is for protection of the plastic tape. The cover tape is needed for the mechanical protection of the magnetic tape. In addition, it protects the magnetic tape from extreme external magnetic influences.

For the complete bonding between the different materials a special sticky tape is used (item 2, item 4, and item 6).

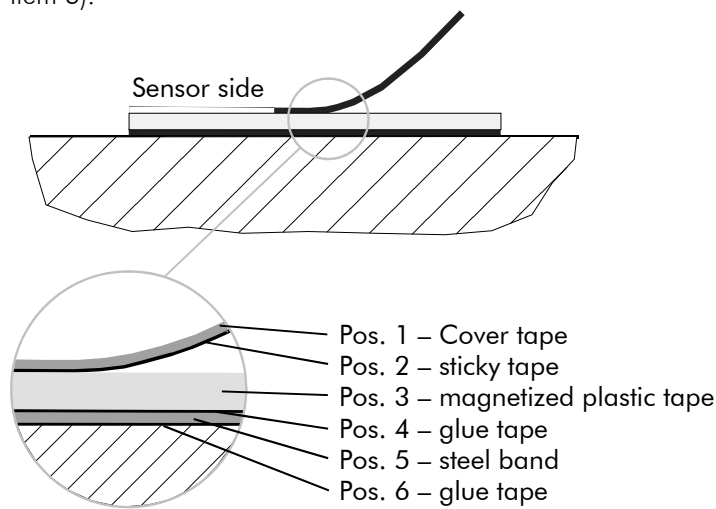

Picture 1: components of magnetic tape

### 7.2 Handling

To avoid tension in the tape, it should not be twisted or stored with the magnetized plastic tape to the inside minimum radius of curvature 150 mm).

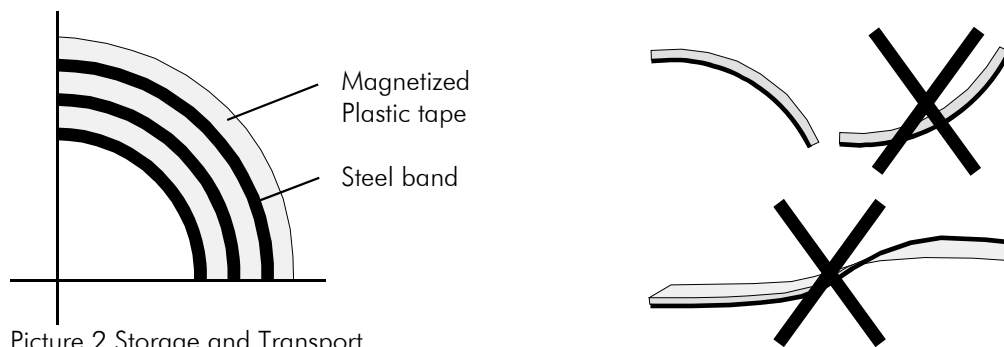

Picture 2 Storage and Transport

### 7.3 Processing instructions for the adjustment of magnetic tapes

**Materials to stick:** The provided sticky tapes stick well on clean, dry and plain surfaces. Typical solvent for cleaning surfaces are a 50/50 mixed isopropyl-alcohol / water mixture or heptane. (Important: Please observe carefully the caution hints of the producer when using the solvent.) The surfaces of materials as copper, brass etc. should be sealed to avoid an oxidation. **Press proof:** The stability of the adhesion is directly depending on the contact, which the adhesive develops to the stuck surfaces together. A high press proof results in a good surface contact. **Sticking temperature:** The optimal sticking temperature is between + 21° C and 38° C. Avoid colder sticking surfaces than + 10°C, because in this case the adhesive becomes to hard and perhaps a sufficient immediate adhesion might be difficult to achieve. After proper sticking the stability of the connection is ensured also when the temperature is below zero. From experience the final tackiness is reached after approximately 72 hours (at + 21° C).



**Note for storage:** In order to avoid tensions in the tape, it should be stored in stretched or rolled up condition - with the magnetized plastic tape resp. scanning side outward (see image).

### 7.4 Resistance against chemical influences

#### Chemicals, showing no or only small effects:

- |                    |                 |               |                 |
|--------------------|-----------------|---------------|-----------------|
| - formic acid      | - glycerol 93°C | - linseed oil | - soy beans oil |
| - cotton seed oil  | - N-hexane      | - lactic acid |                 |
| - formaldehyde 40% | - Iso octane    | - petroleum   |                 |

#### Chemicals, showing small to medium effects:

- |             |                   |                                 |                    |
|-------------|-------------------|---------------------------------|--------------------|
| - acetone   | - gasoline        | - acetic acid 30%               | - Olein acid       |
| - acetylene | - steam           | - acetic acid, pure acetic acid | - sea water        |
| - ammonia   | - acetic acid 20% | - isopropyl ether               | -stearic acid 70°C |
| - anhydrous | - kerosene        |                                 |                    |

#### Chemicals, showing strong effects:

- |                   |                               |                               |                   |
|-------------------|-------------------------------|-------------------------------|-------------------|
| - benzene         | - nitric acid 70%             | - nitrobenzene                | - lacquer solvent |
| - turpentine      | - nitric acid, red, vitriolic | - carbon tetrachloride        | - trichloroethane |
| - tetrahydrofuran | - xylene                      | - hydrochloric acid 37%, 93°C |                   |

### 7.3 Sticking and Cutting

**Note!**

When gluing / sticking the magnetic tape pay attention to the marks on the magnetic tape. Improper installation delivers incorrect values. A previously glued tape is destroyed after removal and cannot be reused. Before the start of the bonding of magnetic tape and masking tape to the exact length basis. Observe also the counting direction of the measuring system. Before adjusting the tape (gluing) please cut the magnetic tape and the cover band to exact length.

$$\text{Length of magnetic tape} = \text{Measuring length} + \text{Sensor length}$$

Preferably, the magnetic tape should be stuck into a nut or aligned to an edge.

Procedure for sticking:

1. The magnetic tape is already factory bonded with the steel band, in between is a double sided sticky tape. Stick the provided sticky tape onto the carrier side (=steel band)
2. Now adjust the magnetic tape and stick it onto the surface. The best way to stick the magnetic tape is to do it in two steps. Remove the first half of the adhesive film from the sticky tape and adjust it then do the rest length.
3. Then stick the sticky tape onto the covering band. It is not important on which side of the covering band the sticky tape is stuck on.
4. Stick the covering band onto the visible brown magnetic tape.

## 8 Interferences

The following chapters describe possible causes for malfunction and the instructions to correct them. If you encounter problems check for proper installation first. Make sure that power is supplied to the system. If you observe recurring errors you might consider electrical interference suppression measures as described in section 8.2. If errors cannot be corrected with the following instructions please contact the manufacturer (see last page).

### 8.1 Security

#### Basics



#### CAUTION!

##### Risks of injury from improper fault clearances!

Improper fault clearances can cause serious personal or property damage.

Therefore:

- Fault clearance may only be carried out by qualified and instructed personnel
- Prior to the beginning of work provide sufficient room to assemble the equipment
- Please look for cleanliness at the place of installation; loosely around laying parts and tools are sources of accidents

If components have to be replaced:

- Look for correct installation of spare parts
- All mounting elements have to be assembled correctly
- Before resetting please ensure that all covers and protective devices are installed correctly and function properly

To ensure a perfect operation of the sensor the following (external) measures have to be taken additionally:

#### Place of installation:

The sensor should not be installed near to sources of interference generating strong inductive or capacitive interferences or strong electrostatic fields.



## 8.2 Electrical interference suppression



Signal wires should be installed separately from load power lines and with a safe distance of at least 0.5 m to capacitive and inductive interferences such as contactors, relays, motors, switching power supplies, timed controllers.

If interferences occur in spite of applying all above mentioned measures proceed as follows:

1. Add RC elements over contactor coils of AC contactors (for example 0,1  $\mu$ F/100  $\Omega$ )
2. Add recovery diodes over DC inductances
3. Add RC elements over each drive phase (in connector box of the drive).
4. Do not connect the GND potential with PE (earth potential)!
5. Install a power filter before the external power supply

## 8.3 Restart after fault clearance

After fault clearance:

1. Reset emergency stop switch.
2. Quit disturbance on sensor.
3. Make sure that no person is located in the danger zone.
4. Start operating as explained in the instructions.

## 8.4 EMC information

A trouble-free operation of the measuring system devices of the company ELGO Electronic GmbH & Co KG can only be guaranteed if during assembly, wiring and operating the following basic rules are observed and adhered to:

- Use only shielded signal lines with a minimum diameter of 0.15 mm<sup>2</sup>
- To protect against electrical fields, connect the cable shield unilaterally, low resistance and low inductive with the operating lightning protection.
- Unused arteries in signal lines should be isolated from each other separately
- Isolate signal and power lines in long parallel lines (a distance of 300 mm is required). Therefore, should never different voltage levels be combined in one cable, e.g. 230V/50 Hz power supply and measuring system signal 24V DC.
- To reduce interference of frequency converters, the use of RC-filter, shielded cable and EMC compliant grounding of frequency converter switchboards are recommended. Please find the necessary instructions in the manufacturer operation manual of the frequency converter.
- Wireless phones and Walky-talkies should never be used in the immediate vicinity of electronic devices

## 9. Maintenance

The unit works maintenance-free.

## 10. Type Designation LMIX1

### Sensor head

**LMIX1 - XXX - XX.X - 2 - XX - XX**

Series  
LMIX1

Version  
000 = Standard  
001 = 1st special Version

Signal cable length  
01.5 = 1.5m (Standard cable length)

Resolution  
1 = 0.1 mm (0.025 mm at 4 edge triggering)

Supply  
00 = 10-30 VDC / 10-30 VDC  
01 = 10-30 VDC / 5V-TTL line driver  
11 = 5 VDC / 5V-TTL line driver

Options  
V = sealed version (IP67)  
R = integrated load resistors (120 Ohm)

### Accessories:

#### **Magnetic tape MB20-50-10-1-R:**

- 0.2 m minimum length
- maximum length theoretical unlimited
- Cover tape is in delivery included
- Hint: Length of the magnetic tape = effective Measuring length + 0.15 m

## 11. Index

<b>C</b>	
Conventional Use	7
<b>D</b>	
Demounting	5
Dimensions	11
Disposal	5
<b>E</b>	
Electrical Interference Suppression	17
<b>G</b>	
General	3
Guarantee	4
<b>I</b>	
Index	20
Interferences	16
<b>M</b>	
Magnetic tape	13
Maintenance	18
Mounting Sensor Head	12
<b>O</b>	
Operation Manual	3
<b>P</b>	
Protective Clothing	6
<b>S</b>	
Security	6
<b>T</b>	
Type Designation	19

