

Unauthorized Photocopy and Duplication Prohibited

Features

- ◆ 5V ~ 30V Supply Voltage Range
- ◆ Low Quiescent Current to 0.6mA (12V to 5V)
- ◆ 32V Input Over Voltage Protection
- ◆ Constant Output Voltage 5V
- ◆ Programmable Frequency (60KHz ~ 1MHz)
- ◆ Hiccup Short Circuit Protection
- ◆ Duty Cycle Range (0~100%)
- ◆ Internal Soft Start 3ms
- ◆ CV Mode Control
- ◆ SOP-8L Package

Applications

- ◆ Car Chargers
- ◆ Portable Charger Devices

◆ DC/DC Converters with Current Limit

General Description

The SP1237F is a synchronous buck Regulator with output current to 2.4A. It is designed to allow for operating a wide supply voltage range from 5V to 30V. The internal compensation requires a minimum number of readily available standard external components.

The SP1237F operates in the CV(Constant output Voltage) mode, and the OCP current value is set by current sensing power resistors.

The SP1237F is suitable for the DC/DC switching power applications when requested the current limit function. The devices are available in SOP-8L package and require very few external devices for operation.

Typical Application Circuit

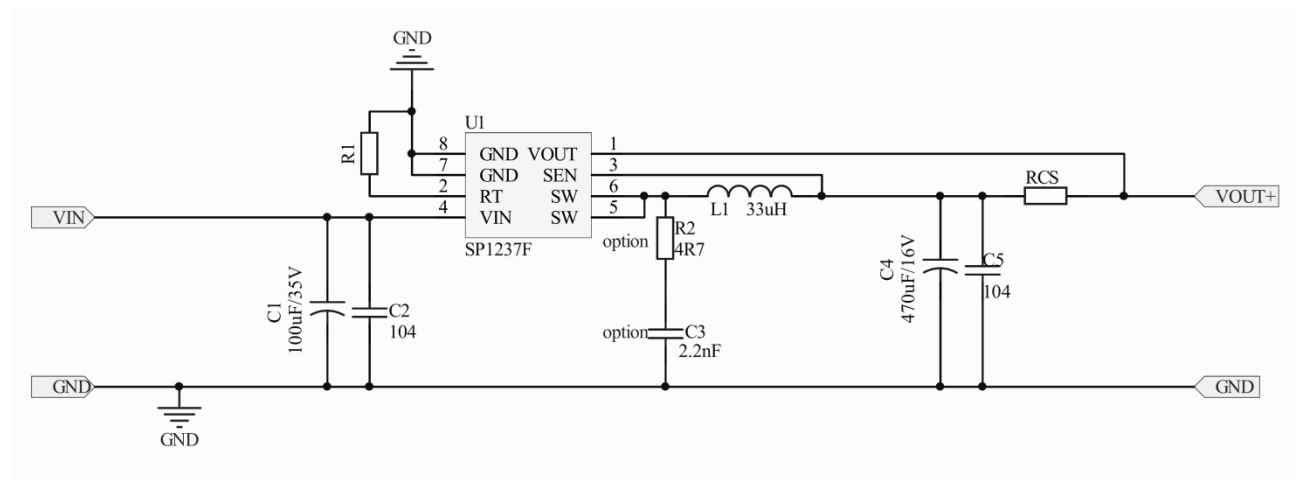

Figure1 Typical Application of SP1237F

Note1:

1. $RCS = 66mV / I_{limit}$, RCS is Power Resistors.
2. $RT = 24000K / f_{osc}$; Float frequency is 120KHz.

Pin Function Description

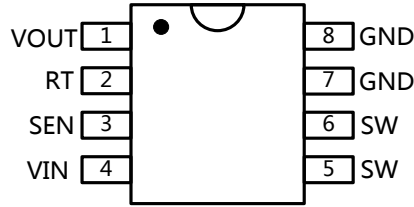
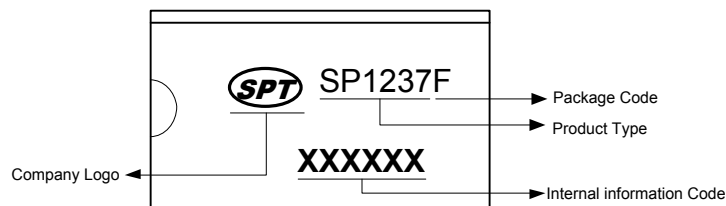

Figure 2 Pin Configuration

Pin No.	Pin Name	Function Description
1	VOUT	Power Supply Output
2	RT	Frequency Setting Pin .Float frequency is 120KHz.
3	SEN	The Current Sense or Setting Input Pin. When the SEN Pin is connected Power resistors to load, the current is set by $66mV/R_{sen}$.
4	VIN	Power Supply Input. Bypass this pin with a 1uF ceramic capacitor to GND, placed as close to the IC as possible.
5,6	SW	Power Switching Output to External Inductor.
7,8	GND	Ground. Connect this pin to a large PCB copper area for best heat dissipation, Connect this GND to power GND at a single point for best noise immunity.

Ordering and Marking Information

Part Number	Package Description	Top Marking	Package Form
SP1237	SOP-8L	SP1237F	SOP-8L



Absolute Maximum Ratings

Characteristics	Symbol	Rating	Units
Supply Input Voltage		-0.3 to +32	V
SW to GND		-1 to +V _{IN} +1	V
V _{OUT} , RT, SEN to GND		0.3 to +7	V
ESD MM(Machine Mode)		±200	V
Power Dissipation, PD @T _A =25°C	P _D	(T _J -T _A)/ θ _{JA}	W
Thermal Resistance from Junction to case	θ _{JC}	40	°C/W
Thermal Resistance from Junction to ambient	θ _{JA}	160	°C/W

Note3:

1. Stresses listed as the above “Absolute Maximum Ratings” may cause permanent damage to the device. These are for stress ratings. Functional operation of the device at these or any other conditions beyond those indicated in the operational sections of the specifications is not implied. Exposure to absolute maximum rating conditions for extended periods may remain possibility to affect device reliability.
2. Devices are ESD sensitive. Handling precaution recommended.
3. θ_{JA} is measured in the natural convection at T_A= 25°C on a high effective thermal conductivity test board of JEDEC51-7 thermal measurement standard.

Recommended Operating Conditions

Symbol	Description	Value	Units
TST	Storage Temperature Range	-65 to +150	°C
TJ	Junction Temperature	-40 to +150	°C
TOP	Operating Temperature	-40 to +85	°C
	Lead Temperature Range(Soldering 10sec)	260	°C

Block Diagram

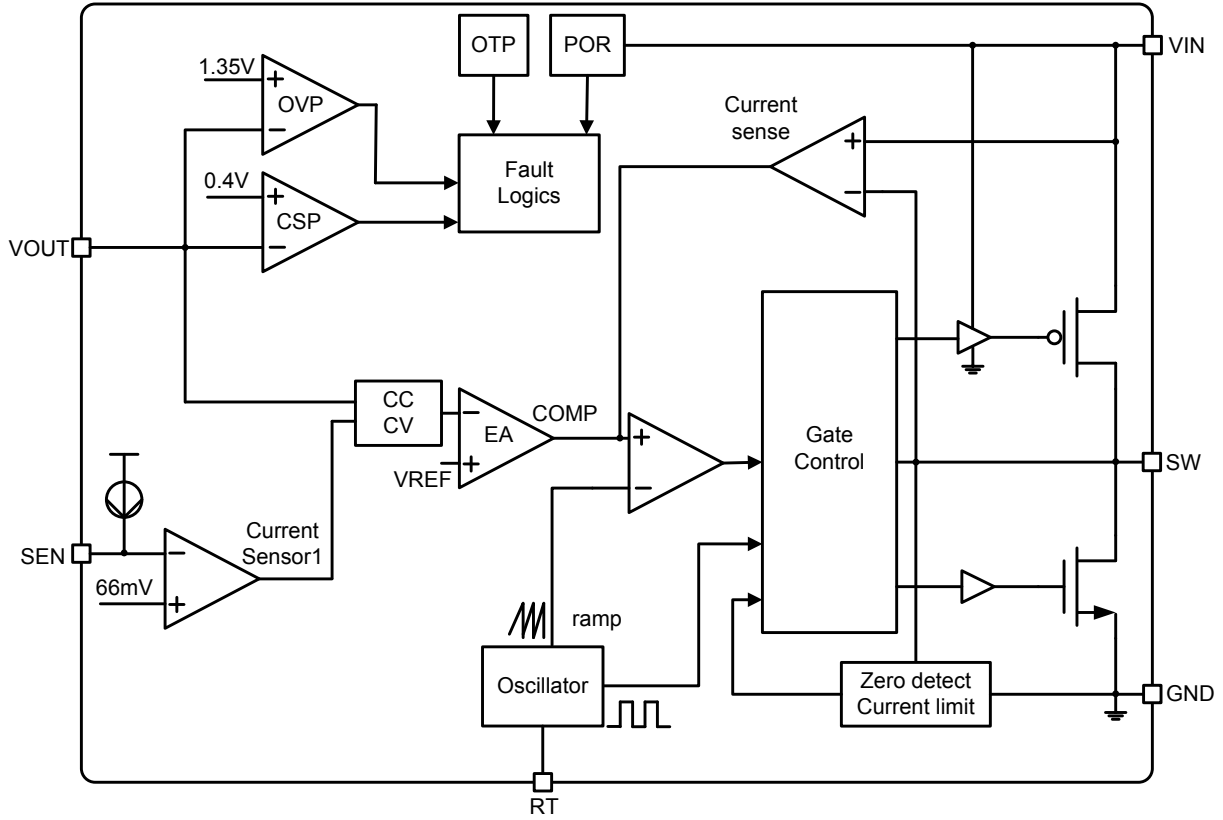

Figure 3 Block diagram of SP1237F

Electrical Characteristics

$V_{CC} = 12V$, $T_A = +25^{\circ}C$, unless otherwise specified

Characteristics	Symbol	Test Conditions	Min	Typ	Max	Units
Supply Voltage Range V_{IN}	V_{CC}		5	-	30	V
Quiescent Current	I_{CCQ}		-	0.4	-	mA
	I_{CC}		-	0.8	-	mA
Power-On-Reset						
VCC POR Threshold	V_{CCRTH}	Vcc Rising.		4.15		V
	V_{CCFTH}	Vcc Falling.		3.75		
Oscillator						
Normal PWM Frequency	F_{OSC}	$I_{OUT}=200\text{ mA}$, RT float	-	120	-	KHz
Duty Cycle Range	Duty		0	-	100	%
Current Sense Amplifier (Power Resistors)						
SEN Voltage	V_{SEN}		60	66	73	mV
Protection						
Over Temperature Shutdown			-	155	-	$^{\circ}C$
Over Temperature Hysteresis			-	40	-	$^{\circ}C$
Soft Start						
Soft Start Time	T_{SS}		-	3	-	ms
Recycle Time			-	500	-	ms
Output Short Circuit Protect Section						
Short Circuit Fold Back Voltage	V_{SCP}		-	0.4	-	V
MOSFET						
Up PMOS On Resestance	R_{dson}			62		m Ω
Down NMOS On Resestance	R_{dson}			23		m Ω

Functional Description

CV mode control

The SP1237F provides CV function. The Constant output Voltage control Mode.

Over Current Protection

The SP1237F provides over current protection. A drop voltage on the current sensing resistor is over the OCP value, the OCP function will shut down the controller.

Soft Start

The SP1237F has internal soft start function to control rise rate of the output voltage and limits the large inrush current at start up. The typical soft start interval is about 3mS.

Power on Reset

A power-on reset circuit monitors the input voltage. When the input voltage exceeds 4.15V, the converter will start operation. Once input voltage falls below 3.75V, the controller will shut down.

Over Temperature Protection

The SP1237F provides over temperature protection. The OTP will shut down the converter when junction temperature exceeds 155°C. Once the junction temperature cools down by approximately 40°C, the converter will resume normal operation.

Current Limit Protection

The SP1237F provides two kinds of current limit Mode. When the SEN Pin series Power Resistors to the load. The current limit set according to the following equation:

$$\text{CurrentLimit(A)} = \frac{66\text{mV}}{R_{\text{SEN}}}$$

Oscillator Frequency

The SP1237F oscillator frequency is set by a single external resistor connected between the RT pin and the GND pin. The resistor should be located very close to the device and connected directly to the pins of the IC (RT and GND). The oscillator frequency rises when the resistor RT falls. To determine the timing resistance for a

given switching frequency, use the equation below:

$$f(\text{KHz}) = \frac{24000\text{K}}{R_T}$$

Output Short-Circuit Protection

The SP1237F provides output short-circuit protection function. When V_{OUT} is short ($V_{\text{OUT}} < 0.4\text{V}$), the auto restart function can be started that restart the regulator cycle by cycle. The cycle time is set by internal counter.

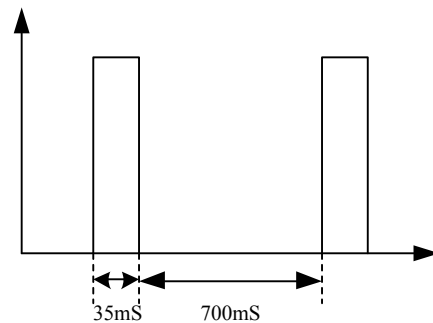

Figure 4 short-circuit protection time.

APPLICATION INFORMATION

Inductor Selection

The inductor maintains a continuous current to the output load. This inductor current has a ripple that is dependent on the inductance value:

Higher inductance reduces the peak-to-peak ripple current. The tradeoff for high inductance value is the increase in inductor core size and series resistance, and the reduction in current handling capability. In general, select an inductance value L based on ripple current requirement:

$$L = \frac{V_{\text{OUT}} \times (V_{\text{IN}} - V_{\text{OUT}})}{V_{\text{IN}} f_{\text{SW}} I_{\text{OUTMAX}} K_{\text{RIPPLE}}}$$

Where V_{IN} is the input voltage, V_{OUT} is the output voltage, f_{SW} is the switching frequency, I_{OUTMAX} is the maximum output current, and K_{RIPPLE} is the ripple factor. Typically, choose $K_{\text{RIPPLE}} = 30\%$ to correspond to the peak-to-peak ripple current being 30% of the maximum output current. With this inductor value, the peak inductor current is $I_{\text{OUT}} \times (1 + K_{\text{RIPPLE}}/2)$. Make sure that this peak inductor current is

less than the controller's current limit. Finally, select the inductor core size so that it does not saturate at the peak inductor current.

Input Capacitor

The input capacitor needs to be carefully selected to maintain sufficiently low ripple at the supply input of the converter. A low ESR capacitor is highly recommended. Since large current flows in and out of this capacitor during switching, its ESR also affects efficiency.

The input capacitance needs to be higher than 100 μ F. The best choice is the ceramic type, however, low ESR tantalum or electrolytic types may also be used provided that the RMS ripple current rating is higher than 50% of the output current. The input capacitor should be placed close to the VIN and GND pins of the IC, with the shortest traces possible. In the case of tantalum or electrolytic types, they can be further away if a small parallel 1 μ F ceramic capacitor is placed right next to the IC. Especially C2 capacitor should be placed as close as possible to the VIN pin.

Output Capacitor

The output capacitor also needs to have low ESR to keep low output voltage ripple. The output ripple voltage is:

$$V_{\text{RIPPLE}} = I_{\text{OUT}} K_{\text{RIPPLE}} R_{\text{ESR}} + \frac{V_{\text{IN}}}{28 \times f_{\text{SW}}^2 L C_{\text{OUT}}}$$

Where I_{OUTMAX} is the maximum output current, K_{RIPPLE} is the ripple factor, R_{ESR} is the ESR of the output capacitor, f_{SW} is the switching frequency, L is the inductor value, and C_{OUT} is the output capacitance. In the case of ceramic output capacitors, R_{ESR} is very small and does not contribute to the ripple. Therefore, a lower capacitance value can be used for ceramic type. In the case of tantalum or electrolytic capacitors, the ripple is dominated by R_{ESR} multiplied by the ripple current. In that case, the output capacitor is chosen to have sufficiently low ESR. For ceramic output capacitor, typically choose a capacitance of about 470 μ F. For tantalum or electrolytic capacitors, choose a capacitor with less than 50m Ω ESR.

PCB Layout Recommendations

1. PCB trace defined as SW node, which connects to the inductor, should be as short and wide as possible.

2. Inductance between the SW terminal and the output VOUT as far as possible with the ground wire to reduce the output side of the switch coupling.

3. ALL sensitive analog traces such as SEN and VOUT should place away from high-voltage switching nodes SW nodes to avoid coupling.

4. Input bypass capacitor should be placed to the IN pin as close as possible.

5. Feedback resistor should be placed to the VOUT pin as close as possible.

6. Gather the ground terminals of the V_{IN} capacitor(s), V_{OUT} capacitor(s), and the source of the low-side MOSFETs as close as possible. Signal ground and power ground should be connected strongly together near the device.

7. The ground of input capacitance and output capacitance should be placed as close as possible.

Package Information (Units:mm)

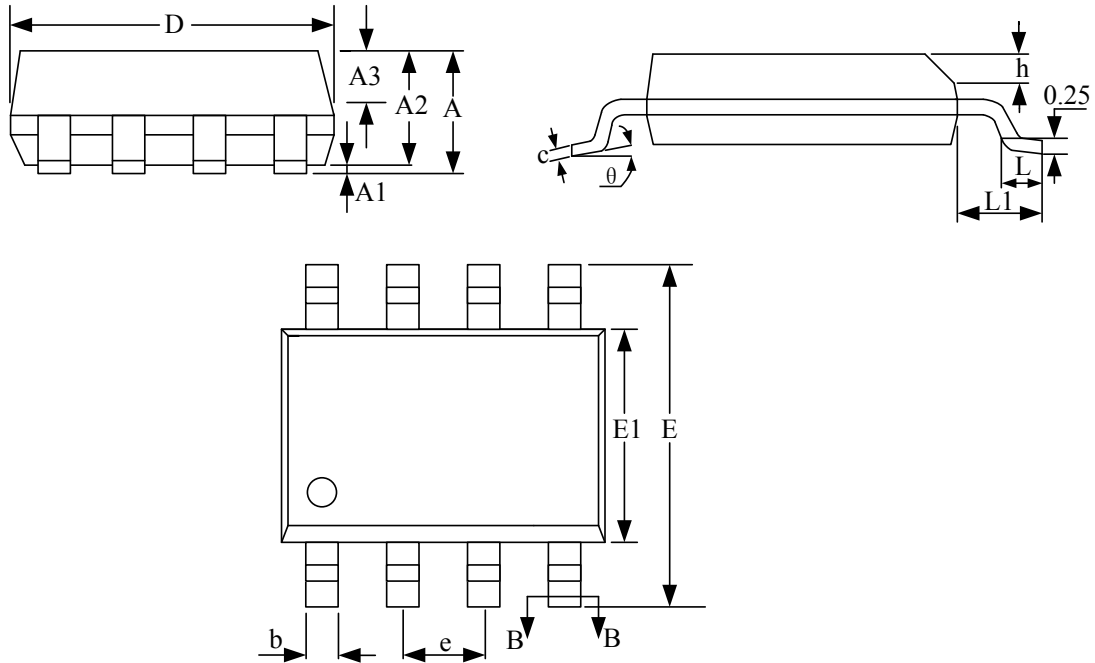

Symbol	Dimensions in Millimeters		
	Min.	Nom.	Max.
A	-	-	1.75
A1	0.05	-	0.15
A2	1.30	1.40	1.50
A3	0.60	0.65	0.70
D	4.70	4.90	5.10
E	5.80	6.00	6.20
E1	3.70	3.90	4.10
e	1.27BSC		
h	0.25	-	0.50
L	0.50	-	0.80
L1	1.05BSC		
θ	0	-	8°

Restrictions on Product Use

- ◆ Si-Power is continually working to improve the quality and reliability of its products. Nevertheless, semiconductor devices in general can malfunction or fail due to their inherent electrical sensitivity and vulnerability to physical stress. It is the responsibility of the buyer, when utilizing Si-Power products, to comply with the standards of safety in making a safe design for the entire system, and to avoid situations in which a malfunction or failure of such Si-Power products could cause loss of human life, bodily injury or damage to property.
- ◆ In developing your designs, please ensure that Si-Power products are used within specified operating ranges as set forth in the most recent Si-Power products specifications.
- ◆ The information contained herein is subject to change without notice.