

Unauthorized Photocopy and Duplication Prohibited

Features

- ◆ 8V ~ 40V Supply Voltage Range
- ◆ 45V Input Voltage Surge
- ◆ 42V Input Over Voltage Protection
- ◆ 3% Voltage Reference Accuracy
- ◆ 7% Constant Current Accuracy
- ◆ Cycle by Cycle Current Limit
- ◆ External Optional Current Limit Mode
- ◆ Programmable Frequency (60KHz ~ 1MHz)
- ◆ Built in Adjustable Line-Compensation
- ◆ Hiccup Short Circuit Protection
- ◆ Duty Cycle Range (0~100%)
- ◆ Internal Soft Start 3ms
- ◆ CC/CV Mode Control
- ◆ SOP-8L Package

General Description

The SP1236FH is a synchronous buck Regulator with output current to 3.1A. It is designed to allow for operating a wide supply voltage range from 8V to 40V. The internal compensation requires a minimum number of readily available standard external components.

The SP1236FH operates in the CC(Constant output Current) mode or CV(Constant output Voltage) mode, and the OCP current value is set by current sensing power resistors or setting non power resistors.

The SP1236FH is suitable for the DC/DC switching power applications when requested the current limit function. The devices are available in SOP-8L package and require very few external devices for operation.

Applications

- ◆ Car Chargers
- ◆ Portable Charger Devices
- ◆ DC/DC Converters with Current Limit

Typical Application Circuit

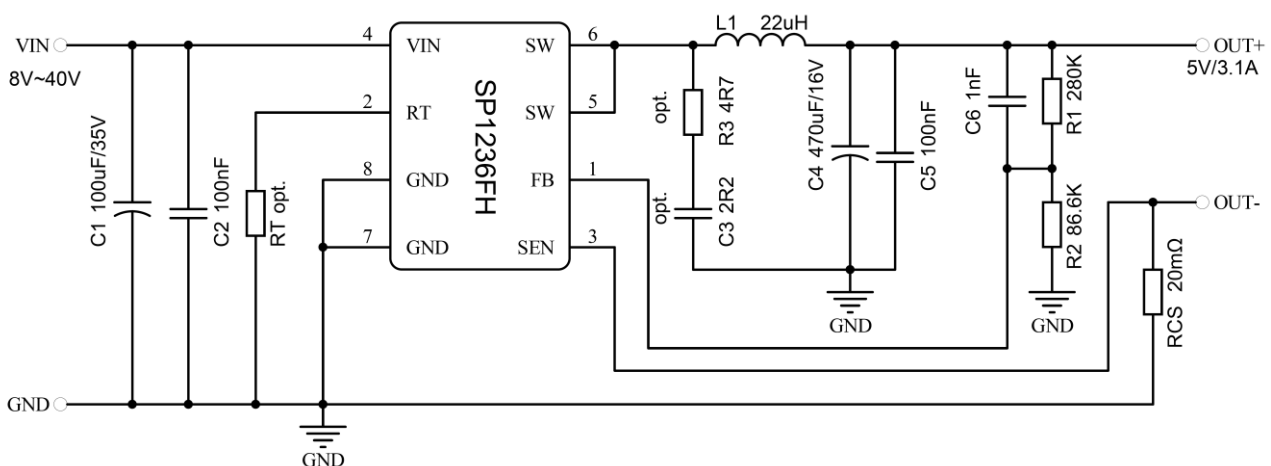

Figure1. Typical Application of SP1236FH(High-accuracy Current Limit)

Note1:

1. $RCS = 66mV / I_{limit}$, RCS is Power Resistor.

2. $RT = 24000K / f_{osc}$, The default frequency is 120KHz when keeping RT pin float.

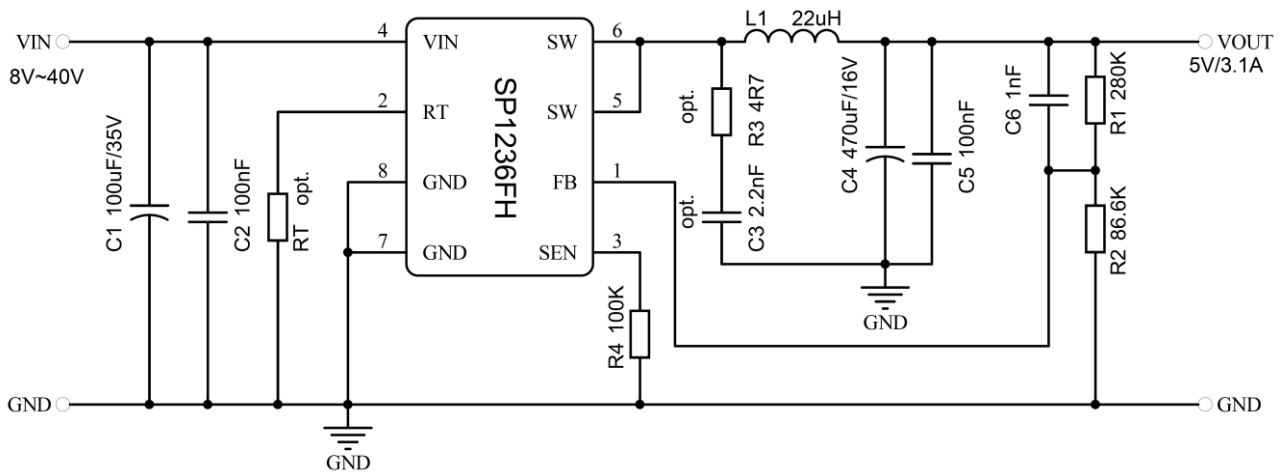

Figure2. Typical Application of SP1236FH(Low-cost Current Limit)

Note2:

1. $R4 > 25K\Omega$.
2. $I_{out} = 3.1A$ recommend $R4 = 100K$.
3. $RT = 24000K/f_{osc}$, The default frequency is 120KHz when keeping RT pin float.

Pin Function Description

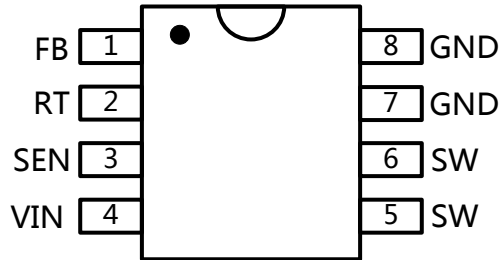
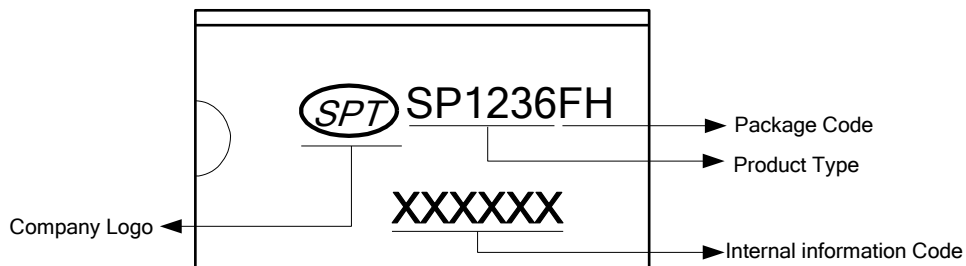

Figure 3. Pin Configuration

Pin No.	Pin Name	Function Description
1	FB	Feedback Pin. The voltage at this pin is regulated to 1.2V. Connect to the resistor divider between output and GND to set the output voltage.
2	RT	Frequency Setting Pin . The pin can float.
3	SEN	The Current Limit Pin. When connected to the Power resistor between output negative and GND, and the SEN Pin is connected to output negative, the current limit is set by $66mV/R_{sen}$. When the SEN Pin is connected Non Power resistor to GND, the current limit is set by note2.
4	VIN	Power Supply Input. Bypass this pin with a 1uF ceramic capacitor to GND, placed as close to the IC as possible.
5,6	SW	Power Switching Output to External Inductor.
7,8	GND	Ground. Connect this pin to a large PCB copper area for best heat dissipation, Return FB to this GND and connect this GND to power GND at a single point for best noise immunity.

Ordering and Marking Information

Part Number	Package Description	Top Marking	Package Form
SP1236	SOP-8L	SP1236FH	SOP-8L



Absolute Maximum Ratings

Characteristics	Symbol	Rating	Units
Supply Input Voltage	V_{IN}	-0.3 to +45	V
SW to GND		-1 to $+V_{IN}+1$	V
FB,RT, SEN to GND		-0.3 to +7	V
ESD HBM(Human Body Mode)		$\pm 2K$	V
ESD MM(Machine Mode)		± 200	V
Power Dissipation, PD @ $T_A=25^\circ C$	P_D	$(T_J-T_A)/\theta_{JA}$	W
Thermal Resistance from Junction to case	θ_{JC}	40	$^\circ C/W$
Thermal Resistance from Junction to ambient	θ_{JA}	160	$^\circ C/W$

Note3:

1. Stresses listed as the above “Absolute Maximum Ratings” may cause permanent damage to the device. These are for stress ratings. Functional operation of the device at these or any other conditions beyond those indicated in the operational sections of the specifications is not implied. Exposure to absolute maximum rating conditions for extended periods may remain possibility to affect device reliability.
2. Devices are ESD sensitive. Handling precaution recommended.
3. θ_{JA} is measured in the natural convection at $T_A= 25^\circ C$ on a high effective thermal conductivity test board of JEDEC51-7 thermal measurement standard.

Recommended Operating Conditions

Symbol	Description	Value	Units
TST	Storage Temperature Range	-65 to +150	$^\circ C$
TJ	Junction Temperature	-40 to +150	$^\circ C$
TOP	Operating Temperature	-40 to +85	$^\circ C$
	Lead Temperature Range(Soldering 10sec)	260	$^\circ C$

Block Diagram

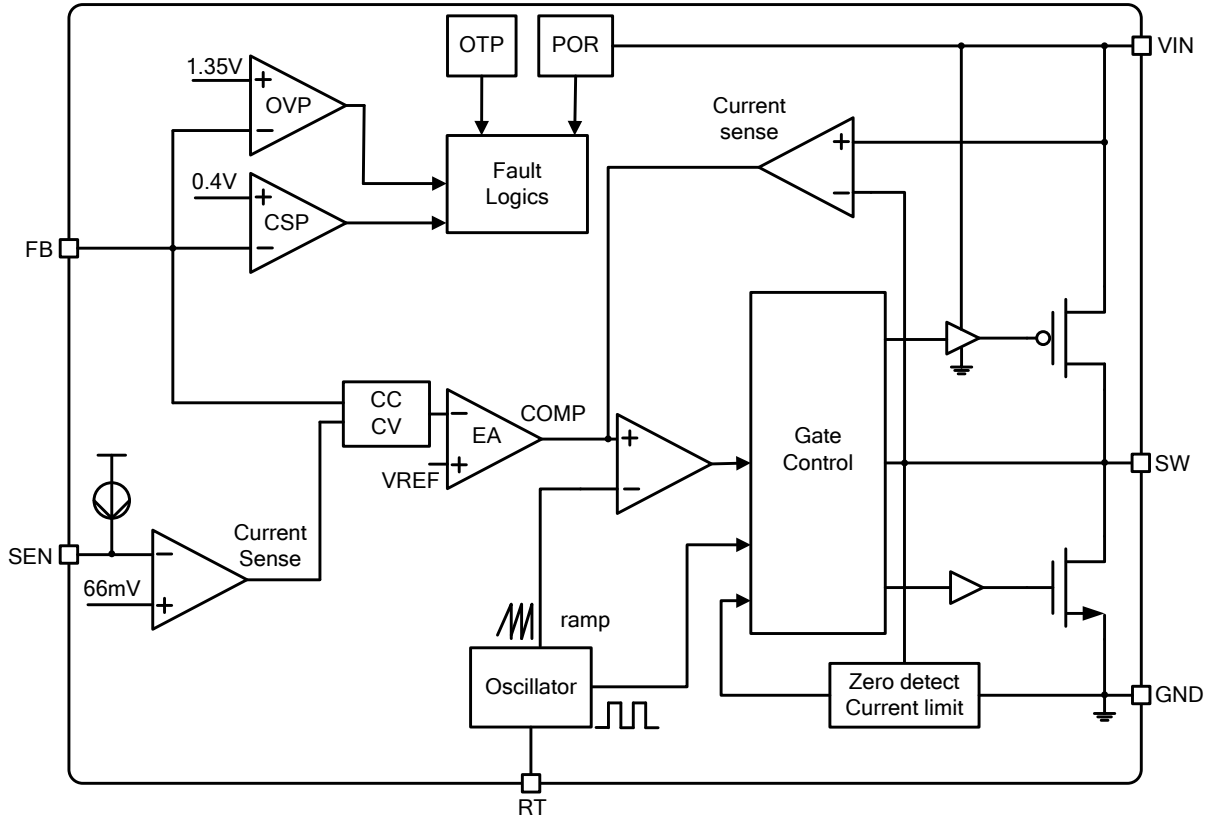

Figure 4. Block diagram of SP1236FH

Electrical Characteristics

V_{CC} = 12V, T_A = +25°C, unless otherwise specified

Characteristics	Symbol	Test Conditions	Min	Typ	Max	Units
Supply Voltage Range V _{IN}	V _{CC}		8	-	40	V
Quiescent Current	I _{CC}	V _{in} =12V, V _{out} =5V, no load	-	0.6	-	mA
	I _{CC}	V _{in} =24V, V _{out} =5V, no load	-	0.4	-	mA
Power-On-Reset						
VCC POR Threshold	V _{CCRTH}	V _{CC} Rising.	-	7.5	-	V
	V _{CCFTH}	V _{CC} Falling.	-	6.0	-	
Input OVP Threshold	V _{IN_OVP}	V _{IN} Rising.	-	42	-	V
	V _{IN_OVP_HYS}	V _{IN} Falling.	-	2.0	-	
Oscillator						
Normal PWM Frequency	F _{OSC}	I _{OUT} =200 mA, RT float	90	120	150	KHz
Duty Cycle Range	Duty		0	-	100	%
Reference						
Reference Voltage	V _{REF}		-	1.2	-	V
Reference Voltage Tolerance			-3	-	+3	%
Line compensation Current	I _{FB}	I _{out} =1A	-	0.44	-	uA
Current Sense Amplifier (Power Resistors)						
SEN Voltage	V _{SEN}		-	66	-	mV
SEN Voltage Tolerance			-7	-	+7	%
Current Set (Non Power Resistors)						
R _{sen} =68K	I _{limit}	V _{in} =12V, V _{out} =5V		3.5		A
R _{sen} =51K	I _{limit}	V _{in} =12V, V _{out} =5V		2.8		A
Protection						
Over Temperature Shutdown			-	160	-	°C
Over Temperature Hysteresis			-	40	-	°C
Soft Start						
Soft Start Time	T _{SS}		-	3	-	ms
Recycle Time			-	500	-	ms
Output Short Circuit Protect Section						
Short Circuit Fold Back Voltage	V _{SCP}		-	0.4	-	V
MOSFET						
Up PMOS On Resestance	R _{dson}			40		mΩ
Down NMOS On Resestance	R _{dson}			26		mΩ

Functional Description

CV/CC mode control

The SP1236FH provides CC/CV function. The Constant output Current control Mode and Constant output Voltage control Mode.

Over Current Protection

The SP1236FH provides over current protection. A drop voltage on the current sensing resistor is over the OCP value, the OCP function will shut down the controller.

Soft Start

The SP1236FH has internal soft start function to control rise rate of the output voltage and limits the large inrush current at start up. The typical soft start interval is about 3mS.

Power on Reset

A power-on reset circuit monitors the input voltage. When the input voltage exceeds 7.5V, the converter will start operation. Once input voltage falls below 6.0V, the controller will shut down.

Over Temperature Protection

The SP1236FH provides over temperature protection. The OTP will shut down the converter when junction temperature exceeds 160°C. Once the junction temperature cools down by approximately 40°C, the converter will resume normal operation.

Current Limit Protection

The SP1236FH provides two kinds of current limit Mode. When connected to the Power resistor between output negative and GND, and the SEN Pin is connected to output negative, the current limit set according to the following equation:

$$CurrentLimit(A) = \frac{66mV}{R_{SEN}}$$

When the SEN Pin is connected the Non Power Resistor to GND, the current limit set according to the following:

Rsen	100K
Iout	3.1A

Oscillator Frequency

The SP1236FH oscillator frequency is set by a single external resistor connected between the RT pin and the GND pin. The resistor should be located very close to the device and connected directly to the pins of the IC (RT and GND). The oscillator frequency rises when the resistor RT falls. To determine the timing resistance for a given switching frequency, use the equation below:

$$f(KHz) = \frac{24000K}{R_T}$$

Output Short-Circuit Protection

The SP1236FH provides output short-circuit protection function. When V_{OUT} is short (V_{FB}<0.4V), the auto restart function can be started that restart the regulator cycle by cycle. The cycle time is set by internal counter.

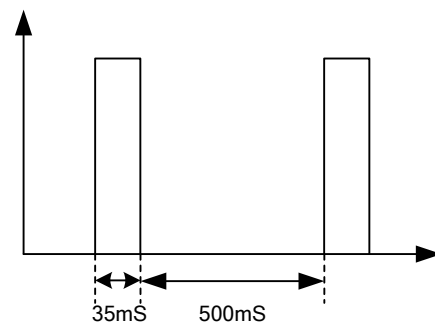

Figure 5. short-circuit protection time

APPLICATION INFORMATION

Output Voltage Setting

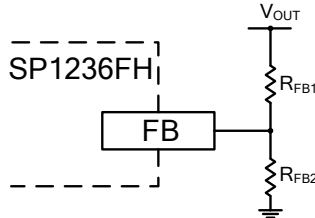

Figure 6. Output Voltage Setting

Figure 6 shows the connections for setting the output voltage. Select the proper ratio of the two feedback resistors R_{FB1} and R_{FB2} based on the output voltage. Typically, use $R_{FB2} > 10k\Omega$ and determine R_{FB1} from the following equation:

$$R_{FB1} = R_{FB2} \left(\frac{V_{OUT}}{1.2} - 1 \right)$$

Output Cable Resistance Compensation

To compensate for resistive voltage drop across the charger's output cable, the SP1236FH integrates a simple, user-programmable cable voltage drop compensation using the impedance at the FB pin. R_{FB1} is the high side resistor of voltage divider.

$$V_{OUT} = \left[\left(1 + \frac{R_{FB1}}{R_{FB2}} \right) \cdot 1.2 \right] + [R_{FB1} \cdot I_{OUT} \cdot 0.44]$$

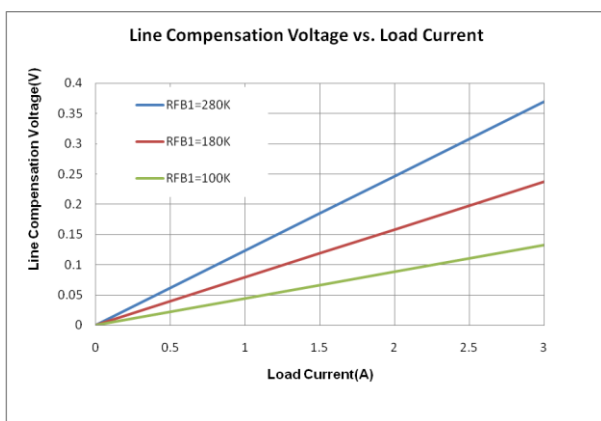

Figure 7. 12V in to 5V out Cable Compensation

Inductor Selection

The inductor maintains a continuous current to the output load. This inductor current has a ripple that is dependent on the inductance value:

Higher inductance reduces the peak-to-peak ripple current. The tradeoff for high inductance value is the increase in inductor core size and series resistance, and the reduction in current handling capability. In general, select an inductance value L based on ripple current requirement:

$$L = \frac{V_{OUT} \times (V_{IN} - V_{OUT})}{V_{IN} f_{SW} I_{OUTMAX} K_{RIPPLE}}$$

Where V_{IN} is the input voltage, V_{OUT} is the output voltage, f_{SW} is the switching frequency, I_{OUTMAX} is the maximum output current, and K_{RIPPLE} is the ripple factor. Typically, choose $K_{RIPPLE} = 30\%$ to correspond to the peak-to-peak ripple current being 30% of the maximum output current.

With this inductor value, the peak inductor current is $I_{OUT} \times (1 + K_{RIPPLE}/2)$. Make sure that this peak inductor current is less than the controller's current limit. Finally, select the inductor core size so that it does not saturate at the peak inductor current.

Input Capacitor

The input capacitor needs to be carefully selected to maintain sufficiently low ripple at the supply input of the converter. A low ESR capacitor is highly recommended. Since large current flows in and out of this capacitor during switching, its ESR also affects efficiency.

The input capacitance needs to be higher than 100 μ F. The best choice is the ceramic type, however, low ESR tantalum or electrolytic types may also be used provided that the RMS ripple current rating is higher than 50% of the output current. The input capacitor should be placed close to the V_{IN} and GND pins of the IC, with the shortest traces possible. In the case of tantalum or electrolytic types, they can be further away if a small parallel 1 μ F ceramic capacitor is placed right next to the IC. Especially C2 capacitor should be placed as close as possible to the V_{IN} pin.

Output Capacitor

The output capacitor also needs to have low ESR to keep low output voltage ripple. The output ripple voltage is:

$$V_{RIPPLE} = I_{OUT} K_{RIPPLE} R_{ESR} + \frac{V_{IN}}{28 \times f_{SW}^2 L C_{OUT}}$$

Where I_{OUTMAX} is the maximum output current, K_{RIPPLE} is

the ripple factor, R_{ESR} is the ESR of the output capacitor, f_{SW} is the switching frequency, L is the inductor value, and C_{OUT} is the output capacitance. In the case of ceramic output capacitors, R_{ESR} is very small and does not contribute to the ripple. Therefore, a lower capacitance value can be used for ceramic type. In the case of tantalum or electrolytic capacitors, the ripple is dominated by R_{ESR} multiplied by the ripple current. In that case, the output capacitor is chosen to have sufficiently low ESR.

For ceramic output capacitor, typically choose a capacitance of about 470 μ F. For tantalum or electrolytic capacitors, choose a capacitor with less than 50m Ω ESR.

PCB Layout Recommendations

1. PCB trace defined as SW node, which connects to the inductor, should be as short and wide as possible.
2. Inductance between the SW terminal and the output VOUT as far as possible with the ground wire to reduce the output side of the switch coupling.
3. ALL sensitive analog traces such as SEN and FB should place away from high-voltage switching nodes SW nodes to avoid coupling.
4. Input bypass capacitor should be placed to the IN pin as close as possible.
5. Feedback resistor should be placed to the FB pin as close as possible.
6. Gather the ground terminals of the V_{IN} capacitor(s), V_{OUT} capacitor(s), and the source of the low-side MOSFETs as close as possible. Signal ground and power ground should be connected strongly together near the device.
7. The ground of input capacitance and output capacitance should be placed as close as possible.

Package Information (Units:mm)

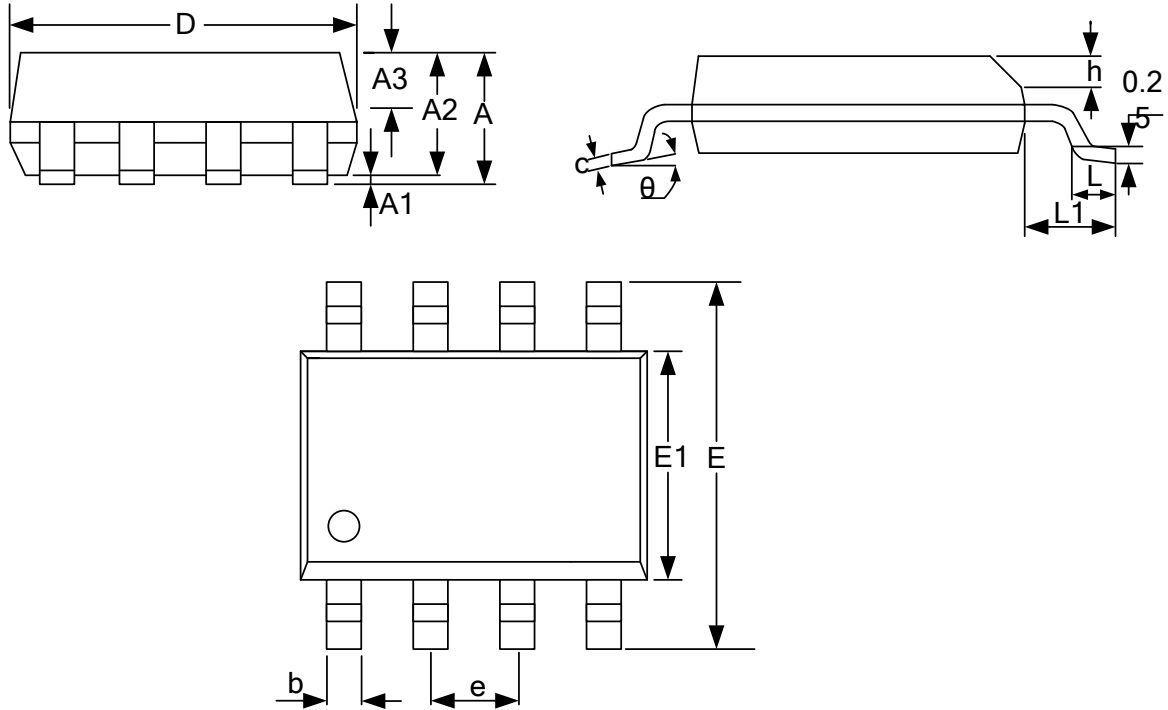

Symbol	Dimensions in Millimeters		
	Min.	Nom.	Max.
A	-	-	1.75
A1	0.05	-	0.15
A2	1.30	1.40	1.50
A3	0.60	0.65	0.70
D	4.70	4.90	5.10
E	5.80	6.00	6.20
E1	3.70	3.90	4.10
b	0.39	-	0.48
c	0.21	-	0.26
e	1.27BSC		
h	0.25	-	0.50
L	0.50	-	0.80
L1	1.05BSC		
θ	0	-	8°

Restrictions on Product Use

- ◆ Si-Power is continually working to improve the quality and reliability of its products. Nevertheless, semiconductor devices in general can malfunction or fail due to their inherent electrical sensitivity and vulnerability to physical stress. It is the responsibility of the buyer, when utilizing Si-Power products, to comply with the standards of safety in making a safe design for the entire system, and to avoid situations in which a malfunction or failure of such Si-Power products could cause loss of human life, bodily injury or damage to property.
- ◆ In developing your designs, please ensure that Si-Power products are used within specified operating ranges as set forth in the most recent Si-Power products specifications.
- ◆ The information contained herein is subject to change without notice.