

# R&S® ESW

## EMI Test Receiver

### User Manual



1177629802

This manual describes the following R&S®ESW models:

- R&S®ESW8 (1328.4100.08)
- R&S®ESW26 (1328.4100.26)
- R&S®ESW44 (1328.4100.44)

The contents of this manual correspond to firmware version 1.50 and higher.

# Safety Instructions

## Instrucciones de seguridad

## Sicherheitshinweise

## Consignes de sécurité

---

### **WARNING**

#### **Risk of injury and instrument damage**

The instrument must be used in an appropriate manner to prevent personal injury or instrument damage.

- Do not open the instrument casing.
  - Read and observe the "Basic Safety Instructions" delivered as printed brochure with the instrument.
  - Read and observe the safety instructions in the following sections. Note that the data sheet may specify additional operating conditions.
  - Keep the "Basic Safety Instructions" and the product documentation in a safe place and pass them on to the subsequent users.
- 

### **ADVERTENCIA**

#### **Riesgo de lesiones y daños en el instrumento**

El instrumento se debe usar de manera adecuada para prevenir descargas eléctricas, incendios, lesiones o daños materiales.

- No abrir la carcasa del instrumento.
  - Lea y cumpla las "Instrucciones de seguridad elementales" suministradas con el instrumento como folleto impreso.
  - Lea y cumpla las instrucciones de seguridad incluidas en las siguientes secciones. Se debe tener en cuenta que las especificaciones técnicas pueden contener condiciones adicionales para su uso.
  - Guarde bien las instrucciones de seguridad elementales, así como la documentación del producto, y entréguelas a usuarios posteriores.
-

---

**⚠️ WARNUNG****Gefahr von Verletzungen und Schäden am Gerät**

Betreiben Sie das Gerät immer ordnungsgemäß, um elektrischen Schlag, Brand, Verletzungen von Personen oder Geräteschäden zu verhindern.

- Öffnen Sie das Gerätegehäuse nicht.
  - Lesen und beachten Sie die "Grundlegenden Sicherheitshinweise", die als gedruckte Broschüre dem Gerät beiliegen.
  - Lesen und beachten Sie die Sicherheitshinweise in den folgenden Abschnitten; möglicherweise enthält das Datenblatt weitere Hinweise zu speziellen Betriebsbedingungen.
  - Bewahren Sie die "Grundlegenden Sicherheitshinweise" und die Produktdokumentation gut auf und geben Sie diese an weitere Benutzer des Produkts weiter.
- 

---

**⚠️ AVERTISSEMENT****Risque de blessures et d'endommagement de l'appareil**

L'appareil doit être utilisé conformément aux prescriptions afin d'éviter les électrocutions, incendies, dommages corporels et matériels.

- N'ouvrez pas le boîtier de l'appareil.
  - Lisez et respectez les "consignes de sécurité fondamentales" fournies avec l'appareil sous forme de brochure imprimée.
  - Lisez et respectez les instructions de sécurité dans les sections suivantes. Il ne faut pas oublier que la fiche technique peut indiquer des conditions d'exploitation supplémentaires.
  - Gardez les consignes de sécurité fondamentales et la documentation produit dans un lieu sûr et transmettez ces documents aux autres utilisateurs.
-



# Customer Support

## **Technical support – where and when you need it**

For quick, expert help with any Rohde & Schwarz equipment, contact one of our Customer Support Centers. A team of highly qualified engineers provides telephone support and will work with you to find a solution to your query on any aspect of the operation, programming or applications of Rohde & Schwarz equipment.

## **Up-to-date information and upgrades**

To keep your instrument up-to-date and to be informed about new application notes related to your instrument, please send an e-mail to the Customer Support Center stating your instrument and your wish. We will take care that you will get the right information.



# Contents

<b>1</b>	<b>Preface</b> .....	<b>15</b>
1.1	<b>About This Manual</b> .....	<b>15</b>
1.2	<b>Documentation Overview</b> .....	<b>16</b>
1.2.1	Getting Started Manual.....	16
1.2.2	User Manuals and Help.....	16
1.2.3	Service Manual.....	16
1.2.4	Instrument Security Procedures.....	17
1.2.5	Basic Safety Instructions.....	17
1.2.6	Data Sheets and Brochures.....	17
1.2.7	Release Notes and Open Source Acknowledgment (OSA).....	17
1.2.8	Application Notes, Application Cards, White Papers, etc.....	17
1.3	<b>Conventions Used in the Documentation</b> .....	<b>18</b>
1.3.1	Typographical Conventions.....	18
1.3.2	Conventions for Procedure Descriptions.....	18
1.3.3	Notes on Screenshots.....	18
<b>2</b>	<b>Preparing for Use</b> .....	<b>19</b>
2.1	<b>Putting into Operation</b> .....	<b>19</b>
2.1.1	Unpacking and Checking the Instrument.....	20
2.1.2	Accessory List.....	21
2.1.3	Placing or Mounting the Instrument.....	21
2.1.4	Connecting the AC Power.....	23
2.1.5	Switching the Instrument On and Off.....	23
2.1.6	Performing a Self-Alignment and a Selftest.....	24
2.1.7	Checking the Supplied Options.....	25
2.2	<b>Windows Operating System</b> .....	<b>25</b>
2.2.1	Virus Protection.....	26
2.2.2	Service Packs and Updates.....	26
2.2.3	Login.....	26
2.2.4	Accessing the Start Menu.....	29
2.2.5	Accessing the Windows Taskbar.....	29
2.3	<b>Connecting USB Devices</b> .....	<b>29</b>

<b>2.4</b>	<b>Connecting an External Monitor.....</b>	<b>31</b>
<b>2.5</b>	<b>Setting Up a Network (LAN) Connection.....</b>	<b>32</b>
2.5.1	Connecting the Instrument to the Network.....	33
2.5.2	Assigning the IP Address.....	34
2.5.3	Using Computer Names.....	36
2.5.4	Changing the Windows Firewall Settings.....	37
<b>2.6</b>	<b>Setting the Date and Time.....</b>	<b>37</b>
<b>2.7</b>	<b>Protecting Data Using the Secure User Mode.....</b>	<b>37</b>
<b>3</b>	<b>Instrument Tour.....</b>	<b>40</b>
<b>3.1</b>	<b>The Front Panel.....</b>	<b>40</b>
3.1.1	Display (Touchscreen).....	41
3.1.2	Power Key.....	43
3.1.3	System Control Keys.....	43
3.1.4	USB Ports.....	43
3.1.5	Probe Power Connector (3 and 5 Pins).....	44
3.1.6	Headphone Jack and Volume Control.....	44
3.1.7	Fast Access Knobs.....	44
3.1.8	RF Inputs (50 $\Omega$ ).....	45
3.1.9	Trigger Input and Output.....	45
3.1.10	Navigation Control.....	45
3.1.11	The Keypad.....	47
3.1.12	The Function Keys.....	48
<b>3.2</b>	<b>The Rear Panel.....</b>	<b>49</b>
3.2.1	Removable Hard Disk.....	50
3.2.2	AC Power Connector and Main Power Switch.....	50
3.2.3	DisplayPort and DVI.....	51
3.2.4	LAN Connector.....	51
3.2.5	USB Ports.....	51
3.2.6	IF / Video / Demod Output.....	51
3.2.7	Sync Trigger Input and Output.....	51
3.2.8	AUX Port.....	52
3.2.9	GPIB Interface.....	52
3.2.10	External Generator Control (Optional).....	52

3.2.11	OCXO (Optional).....	53
3.2.12	REF INPUT / REF OUTPUT.....	53
<b>4</b>	<b>Operating the Instrument.....</b>	<b>54</b>
<b>4.1</b>	<b>Understanding the Display Information.....</b>	<b>54</b>
4.1.1	Channel Bar.....	55
4.1.2	Window Title Bar.....	57
4.1.3	Marker Information.....	58
4.1.4	Frequency and Span Information in Diagram Footer.....	59
4.1.5	Instrument and Status Information.....	59
4.1.6	Error Information.....	60
<b>4.2</b>	<b>Accessing Functions.....</b>	<b>62</b>
4.2.1	Toolbar.....	63
4.2.2	Softkeys.....	64
4.2.3	Context Menus.....	65
4.2.4	On-screen Keyboard.....	65
<b>4.3</b>	<b>Changing the Focus.....</b>	<b>66</b>
<b>4.4</b>	<b>Entering Data.....</b>	<b>66</b>
4.4.1	Entering Numeric Parameters.....	67
4.4.2	Entering Alphanumeric Parameters.....	67
<b>4.5</b>	<b>Displaying Results.....</b>	<b>68</b>
4.5.1	Activating and Deactivating Channels.....	69
4.5.2	Laying out the Result Display with the SmartGrid.....	70
4.5.3	Changing the Size of Windows.....	74
4.5.4	Switching Between a Split and Maximized Window Display.....	75
4.5.5	Changing the Display.....	75
<b>4.6</b>	<b>Getting Help.....</b>	<b>76</b>
4.6.1	Calling Up Help.....	76
4.6.2	Using the Help Window.....	77
<b>4.7</b>	<b>Remote Control.....</b>	<b>78</b>
4.7.1	Using the LXI Browser Interface in a LAN.....	78
4.7.2	Remote Desktop Connection.....	79
4.7.3	Connecting a PC via the GPIB Interface.....	79
<b>5</b>	<b>Collecting Information for Technical Support.....</b>	<b>80</b>

<b>6 Applications.....</b>	<b>81</b>
6.1 R&S MultiView.....	81
6.2 Available Applications.....	82
6.3 Starting an Application.....	84
6.4 Running a Sequence of Measurements.....	85
6.4.1 The Sequencer Concept.....	85
6.4.2 Sequencer Settings.....	88
6.4.3 How to Set Up the Sequencer.....	88
<b>7 Measurements and Result Displays.....</b>	<b>90</b>
7.1 Performing Measurements.....	90
7.2 Bargraph Configuration.....	92
7.3 Test Automation.....	97
7.3.1 Background Information.....	97
7.3.2 Selecting a Test Sequence.....	106
7.3.3 Performing a Scan.....	109
7.3.4 Performing a Peak Search.....	117
7.3.5 Performing Final Measurements.....	124
7.3.6 Configuring Line Impedance Stabilization Networks (LISN).....	129
7.4 CISPR APD Measurements.....	131
<b>8 Common Measurement Settings.....</b>	<b>135</b>
8.1 Using the Fast Access Knobs.....	135
8.2 Using the Fast Access Panel.....	137
8.3 Configuration Overview.....	139
8.4 Data Input and Output.....	141
8.4.1 Configuring the Input.....	141
8.4.2 Configuring the Preselector.....	142
8.4.3 External Generator.....	144
8.4.4 Configuring Outputs (IF / Video / Demodulation).....	156
8.4.5 Configuring LISNs.....	160
8.4.6 Configuring Additional Outputs.....	160
8.5 Amplitude and Vertical Axis Configuration.....	162
8.5.1 Increasing Measurement Sensitivity (or Avoiding an Input Mixer Overload).....	162
8.5.2 Amplitude Settings.....	165

8.5.3	Diagram Scale.....	167
8.5.4	Preselector.....	168
<b>8.6</b>	<b>Frequency and Span Configuration.....</b>	<b>168</b>
8.6.1	Impact of the Frequency and Span Settings.....	168
8.6.2	Frequency and Span Settings.....	171
<b>8.7</b>	<b>Bandwidth and Filter Configuration.....</b>	<b>174</b>
8.7.1	Impact of Bandwidth and Filter Settings.....	174
8.7.2	Bandwidth and Filter Settings.....	174
<b>8.8</b>	<b>Trigger Configuration.....</b>	<b>175</b>
8.8.1	Basics on Triggered Measurements.....	175
8.8.2	Triggering Measurements.....	178
<b>9</b>	<b>Common Analysis and Display Functions.....</b>	<b>182</b>
<b>9.1</b>	<b>Result Display Configuration.....</b>	<b>182</b>
9.1.1	Basic Evaluation Methods.....	182
9.1.2	Laying out the Result Display with the SmartGrid.....	183
<b>9.2</b>	<b>Zoomed Displays.....</b>	<b>187</b>
9.2.1	Zoom Functions.....	188
9.2.2	How to Zoom into the Diagram in Receiver Mode.....	188
<b>9.3</b>	<b>Trace Configuration.....</b>	<b>189</b>
9.3.1	Basics on Traces.....	190
9.3.2	Trace Configuration.....	203
9.3.3	Trace Export.....	203
9.3.4	Copying Traces.....	205
9.3.5	Trace Mathematics.....	205
9.3.6	Spectrogram Settings.....	207
9.3.7	How to Configure Traces.....	211
9.3.8	References.....	216
<b>9.4</b>	<b>Marker Usage.....</b>	<b>218</b>
9.4.1	Basics on Markers.....	218
9.4.2	Marker Settings.....	222
9.4.3	Marker Search Settings and Positioning Functions.....	226
<b>9.5</b>	<b>Display and Limit Lines.....</b>	<b>231</b>
9.5.1	Display Lines.....	231

9.5.2	Limit Lines.....	233
<b>10</b>	<b>Data Management.....</b>	<b>248</b>
10.1	Restoring the Default Instrument Configuration (Preset).....	248
10.2	Protecting Data Using the Secure User Mode.....	249
10.3	Storing and Recalling Instrument Settings and Measurement Data.....	251
10.3.1	Quick Save/Quick Recall.....	252
10.3.2	Configurable Storage and Recall.....	254
10.3.3	How to Save and Load Instrument Settings.....	259
10.4	Import/Export Functions.....	261
10.5	I/Q Data Import and Export.....	262
10.5.1	Import/Export Functions.....	263
10.5.2	I/Q Data File Format (iq-tar).....	264
10.6	Creating Screenshots of Current Measurement Results and Settings.....	270
10.6.1	Print and Screenshot Settings.....	270
10.6.2	How to Store or Print Screenshots of the Display.....	278
10.6.3	Example for Storing Multiple Measurement Results to a PDF File.....	280
10.7	Working with Test Reports.....	282
10.7.1	Designing a Test Report Template.....	282
10.7.2	Creating a Test Report.....	287
<b>11</b>	<b>General Instrument Setup.....</b>	<b>289</b>
11.1	Alignment.....	289
11.1.1	Basics on Alignment.....	289
11.1.2	Alignment Settings.....	291
11.1.3	How to Perform a Self-Test.....	293
11.1.4	How to Align the Instrument.....	293
11.1.5	How to Align the Touchscreen.....	294
11.2	Display Settings.....	294
11.2.1	Display Settings.....	294
11.2.2	External Monitor Settings.....	303
11.2.3	How to Configure the Colors for Display and Printing.....	303
11.2.4	How to Work with the Soft Front Panels.....	304
11.3	Transducers.....	305
11.3.1	Transducer.....	305

11.3.2	Working with Transducers.....	307
11.3.3	Reference: Transducer Factor File Format.....	315
11.3.4	How to Configure the Transducer.....	316
<b>11.4</b>	<b>Reference Frequency Settings.....</b>	<b>320</b>
<b>11.5</b>	<b>System Configuration Settings.....</b>	<b>323</b>
11.5.1	Hardware Information.....	323
11.5.2	Information on Versions and Options.....	323
11.5.3	System Messages.....	325
11.5.4	Firmware Updates.....	325
11.5.5	General Configuration Settings.....	327
<b>11.6</b>	<b>Service Functions.....</b>	<b>329</b>
11.6.1	R&S Support Information.....	329
11.6.2	Self-test Settings and Results.....	330
11.6.3	Calibration Signal Display.....	331
11.6.4	Service Functions.....	332
11.6.5	Hardware Diagnostics.....	334
<b>11.7</b>	<b>Synchronizing Measurement Channel Configuration.....</b>	<b>335</b>
11.7.1	General Parameter Coupling.....	335
11.7.2	Using the Custom Coupling Manager.....	338
11.7.3	Example for a User-Defined Parameter Coupling.....	341
<b>12</b>	<b>Network and Remote Operation.....</b>	<b>344</b>
<b>12.1</b>	<b>Remote Control Basics.....</b>	<b>344</b>
12.1.1	Remote Control Interfaces and Protocols.....	344
12.1.2	SCPI (Standard Commands for Programmable Instruments).....	353
12.1.3	VISA Libraries.....	353
12.1.4	Messages.....	354
12.1.5	SCPI Command Structure.....	355
12.1.6	Command Sequence and Synchronization.....	363
12.1.7	Status Reporting System.....	365
12.1.8	General Programming Recommendations.....	382
<b>12.2</b>	<b>GPIB Languages.....</b>	<b>383</b>
<b>12.3</b>	<b>The IECWIN Tool.....</b>	<b>385</b>
<b>12.4</b>	<b>Network and Remote Control Settings.....</b>	<b>386</b>



12.4.1	General Network Settings.....	386
12.4.2	GPIB Settings.....	388
12.4.3	Compatibility Settings.....	390
12.4.4	LXI Settings.....	393
12.4.5	Remote Errors.....	395
12.4.6	Returning to Manual Mode ("Local").....	396
<b>12.5</b>	<b>How to Set Up a Network and Remote Control.....</b>	<b>397</b>
12.5.1	How to Configure a Network.....	397
12.5.2	How to Operate the Instrument Without a Network.....	403
12.5.3	How to Log on to the Network.....	404
12.5.4	How to Share Directories (only with Microsoft Networks).....	406
12.5.5	How to Control the R&S ESW via the Web Browser Interface.....	406
12.5.6	How to Deactivate the Web Browser Interface.....	407
12.5.7	How to Set Up Remote Desktop.....	408
12.5.8	How to Start a Remote Control Session from a PC.....	414
12.5.9	How to Return to Manual Operation.....	415
<b>13</b>	<b>Remote Commands in the Receiver Application.....</b>	<b>416</b>
<b>13.1</b>	<b>Conventions Used in SCPI Command Descriptions.....</b>	<b>416</b>
<b>13.2</b>	<b>Common Suffixes.....</b>	<b>417</b>
<b>13.3</b>	<b>Common Commands.....</b>	<b>417</b>
<b>13.4</b>	<b>Application Selection.....</b>	<b>422</b>
<b>13.5</b>	<b>Measurements and Result Displays.....</b>	<b>426</b>
13.5.1	Measurement Control.....	426
13.5.2	Measurement Sequences.....	430
13.5.3	Result Retrieval.....	433
13.5.4	Bargraph Configuration.....	438
13.5.5	Scan Configuration.....	440
13.5.6	Scan Table Configuration.....	442
13.5.7	Peak Search.....	450
13.5.8	Peak List.....	455
13.5.9	Final Measurement (and Trace) Configuration.....	460
13.5.10	Final Results.....	464
13.5.11	LISN Configuration.....	468

13.5.12	CISPR APD Measurement Configuration.....	470
13.5.13	Programming Example: Performing a Sequence of Measurements.....	471
	<b>13.6 Configuration.....</b>	<b>473</b>
13.6.1	Input Configuration.....	473
13.6.2	Output Configuration.....	483
13.6.3	Frequency Configuration.....	491
13.6.4	Amplitude Configuration.....	493
13.6.5	Diagram Scale.....	497
13.6.6	Bandwidth and Filter Configuration.....	497
13.6.7	Trigger Configuration.....	499
	<b>13.7 Analysis.....</b>	<b>504</b>
13.7.1	Result Display Configuration.....	504
13.7.2	Zoomed Displays.....	513
13.7.3	Trace Configuration.....	514
13.7.4	Markers.....	524
13.7.5	Display and Limit Line Configuration.....	548
	<b>13.8 Data Management.....</b>	<b>567</b>
13.8.1	File Management.....	568
13.8.2	Items to Store.....	575
13.8.3	Instrument Setting Management.....	578
13.8.4	Screenshots and Printouts.....	582
13.8.5	Test Reports.....	594
13.8.6	Measurement Result Export.....	606
13.8.7	Examples: Managing Data.....	607
	<b>13.9 General Instrument Setup.....</b>	<b>610</b>
13.9.1	Basic Instrument Setup.....	610
13.9.2	Reference Frequency Configuration.....	611
13.9.3	Calibration and Temperature Check.....	614
13.9.4	Transducers.....	618
13.9.5	Display Layout and Elements.....	629
13.9.6	Measurement Channel Synchronization.....	637
13.9.7	Network and Remote Control Configuration.....	649
13.9.8	System Configuration Check.....	656

13.9.9	Service Functions.....	662
<b>13.10</b>	<b>Using the Status Register.....</b>	<b>664</b>
13.10.1	General Status Register Commands.....	665
13.10.2	Reading Out the CONDition Part.....	665
13.10.3	Reading Out the EVENT Part.....	666
13.10.4	Controlling the ENABLE Part.....	667
13.10.5	Controlling the Negative Transition Part.....	667
13.10.6	Controlling the Positive Transition Part.....	668
<b>13.11</b>	<b>Service Request.....</b>	<b>669</b>
13.11.1	Initiate Service Request.....	669
13.11.2	Waiting for the Arrival of a Service Request.....	669
13.11.3	Waiting Without Blocking the Keyboard and Mouse.....	671
13.11.4	Service Request Routine.....	672
13.11.5	Reading Out the Output Buffer.....	673
13.11.6	Reading Error Messages.....	673
13.11.7	Evaluation of SCPI Status Registers.....	674
13.11.8	Evaluation of Event Status Register.....	675
<b>13.12</b>	<b>Reference: GPIB Commands of Emulated HP Models.....</b>	<b>676</b>
13.12.1	Command Set of Models 8560E, 8561E, 8562E, 8563E, 8564E, 8565E, 8566A/B, 8568A/B, 8591E, 8594E, 71100C, 71200C, and 71209A.....	676
13.12.2	Special Features of the Syntax Parsing Algorithms for 8566A and 8568A Models....	700
13.12.3	Special Behavior of Commands.....	701
13.12.4	Model-Dependent Default Settings.....	702
13.12.5	Data Output Formats.....	703
13.12.6	Trace Data Output Formats.....	703
13.12.7	Trace Data Input Formats.....	703
13.12.8	GPIB Status Reporting.....	703
<b>13.13</b>	<b>Reference: Command Set of Emulated PSA Models.....</b>	<b>704</b>
<b>13.14</b>	<b>Reference: Command Set of Emulated PXA Models.....</b>	<b>708</b>
<b>14</b>	<b>Maintenance.....</b>	<b>711</b>
<b>14.1</b>	<b>Cleaning.....</b>	<b>711</b>
<b>15</b>	<b>Troubleshooting.....</b>	<b>713</b>
<b>15.1</b>	<b>Error Information.....</b>	<b>713</b>

<b>15.2</b>	<b>Error Messages in Remote Control Mode.....</b>	<b>714</b>
<b>15.3</b>	<b>Troubleshooting Remote Operation.....</b>	<b>715</b>
<b>15.4</b>	<b>Miscellaneous Troubleshooting Hints.....</b>	<b>717</b>
<b>15.5</b>	<b>Collecting Information for Technical Support.....</b>	<b>718</b>
	<b>List of Commands.....</b>	<b>720</b>
	<b>Index.....</b>	<b>734</b>



# 1 Preface

## 1.1 About This Manual

This user manual describes general instrument functions and settings common to all applications and operating modes in the R&S ESW. Furthermore, it provides all the information specific to **EMI measurements in the receiver application**.

All other operating modes and applications are described in the specific application manuals.

The main focus in this manual is on the measurement results and the tasks required to obtain them. The following topics are included:

- **Welcome to the R&S ESW**  
Introduction to and getting familiar with the instrument
- **Operating modes and applications**  
The concept of using multiple operating modes
- **Measurements**  
Descriptions of the individual measurements in the receiver application, including result types and configuration settings.
- **Common measurement settings**  
Description of the measurement settings common to all measurement types with their corresponding remote control commands
- **Common measurement analysis and display functions**  
Description of the settings and functions provided to analyze results independently of the measurement type with their corresponding remote control commands
- **Data management**  
Description of general functions to handle data files (configuration and result data, not I/Q data)
- **General instrument setup**  
Description of general instrument settings and functions that are independent of the current operating mode
- **Network and remote operation**  
Information on setting up the instrument in a network and operating it remotely.
- **Remote commands**  
Remote commands required to configure and run measurements in a remote environment, sorted by tasks  
Remote commands required to set up the environment and to perform common tasks on the instrument, sorted by tasks  
Programming examples demonstrate the use of many commands and can usually be executed directly for test purposes
- **Maintenance**  
Information on tasks required to maintain operability of the instrument
- **Troubleshooting**  
Hints and tips on how to handle errors

- **List of commands**  
Alphabetical list of all remote commands described in the manual
- **Index**

## 1.2 Documentation Overview

This section provides an overview of the R&S ESW user documentation. You find it on the product page at:

### 1.2.1 Getting Started Manual

Introduces the R&S ESW and describes how to set up and start working with the product. Includes basic operations, typical measurement examples, and general information, e.g. safety instructions, etc.

A printed version is delivered with the instrument. A PDF version is available for download on the Internet.

### 1.2.2 User Manuals and Help

Separate user manuals are provided for the base unit and the firmware applications:

- **Base unit manual**  
Contains the description of all instrument modes and functions. It also provides an introduction to remote control, a complete description of the remote control commands with programming examples, and information on maintenance, instrument interfaces and error messages. Includes the contents of the getting started manual.
- **Manuals for (optional) firmware applications**  
Contains the description of the specific functions of a firmware application, including remote control commands. Basic information on operating the R&S ESW is not included.

The contents of the user manuals are available as help in the R&S ESW. The help offers quick, context-sensitive access to the complete information for the base unit and the firmware applications.

All user manuals are also available for download or for immediate display on the Internet.

### 1.2.3 Service Manual

Describes the performance test for checking the rated specifications, module replacement and repair, firmware update, troubleshooting and fault elimination, and contains mechanical drawings and spare part lists.

The service manual is available for download for registered users on the global Rohde & Schwarz information system (GLORIS):

#### **1.2.4 Instrument Security Procedures**

Deals with security issues when working with the R&S ESW in secure areas. It is available for download on the Internet.

#### **1.2.5 Basic Safety Instructions**

Contains safety instructions, operating conditions and further important information. The printed document is delivered with the instrument.

#### **1.2.6 Data Sheets and Brochures**

The data sheet contains the technical specifications of the R&S ESW. It also lists the options and their order numbers, and optional accessories.

The brochure provides an overview of the instrument and deals with the specific characteristics.

#### **1.2.7 Release Notes and Open Source Acknowledgment (OSA)**

The release notes list new features, improvements and known issues of the current firmware version, and describe the firmware installation.

The open source acknowledgment document provides verbatim license texts of the used open source software.

#### **1.2.8 Application Notes, Application Cards, White Papers, etc.**

These documents deal with special applications or background information on particular topics.



## 1.3 Conventions Used in the Documentation

### 1.3.1 Typographical Conventions

The following text markers are used throughout this documentation:

Convention	Description
"Graphical user interface elements"	All names of graphical user interface elements on the screen, such as dialog boxes, menus, options, buttons, and softkeys are enclosed by quotation marks.
[Keys]	Key and knob names are enclosed by square brackets.
File names, commands, program code	File names, commands, coding samples and screen output are distinguished by their font.
<i>Input</i>	Input to be entered by the user is displayed in italics.
<a href="#">Links</a>	Links that you can click are displayed in blue font.
"References"	References to other parts of the documentation are enclosed by quotation marks.

### 1.3.2 Conventions for Procedure Descriptions

When operating the instrument, several alternative methods may be available to perform the same task. In this case, the procedure using the touchscreen is described. Any elements that can be activated by touching can also be clicked using an additionally connected mouse. The alternative procedure using the keys on the instrument or the on-screen keyboard is only described if it deviates from the standard operating procedures.

The term "select" may refer to any of the described methods, i.e. using a finger on the touchscreen, a mouse pointer in the display, or a key on the instrument or on a keyboard.

### 1.3.3 Notes on Screenshots

When describing the functions of the product, we use sample screenshots. These screenshots are meant to illustrate as many as possible of the provided functions and possible interdependencies between parameters. The shown values may not represent realistic usage scenarios.

The screenshots usually show a fully equipped product, that is: with all options installed. Thus, some functions shown in the screenshots may not be available in your particular product configuration.

## 2 Preparing for Use

- Putting into Operation..... 19
- Windows Operating System.....25
- Connecting USB Devices.....29
- Connecting an External Monitor.....31
- Setting Up a Network (LAN) Connection.....32
- Setting the Date and Time..... 37
- Protecting Data Using the Secure User Mode..... 37

### 2.1 Putting into Operation

This section describes the basic steps to be taken when setting up the R&S ESW for the first time.

---

#### **WARNING**

##### **Risk of injury due to disregarding safety information**

Observe the information on appropriate operating conditions provided in the data sheet to prevent personal injury or damage to the instrument. Read and observe the basic safety instructions provided with the instrument, in addition to the safety instructions in the following sections. In particular:

- Do not open the instrument casing.
- 

---

#### **NOTICE**

##### **Risk of instrument damage due to inappropriate operating conditions**

Specific operating conditions are required to ensure accurate measurements and to avoid damage to the instrument. Observe the information on appropriate operating conditions provided in the basic safety instructions and the instrument's data sheet.

---



---

#### **NOTICE**

##### **Instrument damage caused by electrostatic discharge**

Electrostatic discharge (ESD) can damage the electronic components of the instrument and the device under test (DUT). Electrostatic discharge is most likely to occur when you connect or disconnect a DUT or test fixture to the instrument's test ports. To prevent electrostatic discharge, use a wrist strap and cord and connect yourself to the ground, or use a conductive floor mat and heel strap combination.

---

**NOTICE****Risk of instrument damage due to inappropriate operating conditions**

An unsuitable operating site or test setup can damage the instrument and connected devices. Before switching on the instrument, observe the information on appropriate operating conditions provided in the data sheet. In particular, ensure the following:

- All fan openings are unobstructed and the airflow perforations are unimpeded. The minimum distance from the wall is 10 cm.
- The instrument is dry and shows no sign of condensation.
- The instrument is positioned as described in the following sections.
- The ambient temperature does not exceed the range specified in the data sheet.
- Signal levels at the input connectors are all within the specified ranges.
- Signal outputs are connected correctly and are not overloaded.

**EMI impact on measurement results**

Electromagnetic interference (EMI) may affect the measurement results.

To suppress generated electromagnetic interference (EMI):

- Use suitable shielded cables of high quality. For example, use double-shielded RF and LAN cables.
- Always terminate open cable ends.
- Note the EMC classification in the data sheet.

• <a href="#">Unpacking and Checking the Instrument</a> .....	20
• <a href="#">Accessory List</a> .....	21
• <a href="#">Placing or Mounting the Instrument</a> .....	21
• <a href="#">Connecting the AC Power</a> .....	23
• <a href="#">Switching the Instrument On and Off</a> .....	23
• <a href="#">Performing a Self-Alignment and a Selftest</a> .....	24
• <a href="#">Checking the Supplied Options</a> .....	25

**2.1.1 Unpacking and Checking the Instrument**

Check the equipment for completeness using the delivery note and the accessory lists for the various items. Check the instrument for any damage. If there is damage, immediately contact the carrier who delivered the instrument. Make sure not to discard the box and packing material.

---

**⚠ WARNING****Risk of injury during transportation**

The carrying handles at the front and side of the casing are designed to lift or carry the instrument. Do not apply excessive force to the handles. If a handle is ripped off, the falling instrument can cause injury.

Be aware of the weight of the instrument when lifting it. Observe the information on transporting heavy instruments in the basic safety instructions provided with the instrument.

---

**Packing material**

Retain the original packing material. If the instrument needs to be transported or shipped later, you can use the material to protect the control elements and connectors.

---

### 2.1.2 Accessory List

The instrument comes with the following accessories:

- Power cable
- Printed Getting Started manual

### 2.1.3 Placing or Mounting the Instrument

The R&S ESW is designed for use under laboratory conditions, either on a bench top or in a rack.

**Bench Top Operation**

If the R&S ESW is operated on a bench top, the surface should be flat. The instrument can be used in horizontal position, standing on its feet, or with the support feet on the bottom extended.

**⚠ WARNING****Risk of injury when stacking instruments**

A stack of instruments can tilt over and cause injury if not stacked correctly. Furthermore, the instruments at the bottom of the stack can be damaged due to the load imposed by the instruments on top.

Observe the following instructions when stacking instruments:

- Never stack more than three instruments. If you need to stack more than three instruments, install them in a rack.
- The overall load imposed on the lowest instrument must not exceed 500 N.
- It is best if all instruments have the same dimensions (width and length). If you need to stack smaller instruments on the top, the overall load imposed on the lowest instrument must not exceed 250 N.
- If the instruments have foldable feet, fold them in completely.

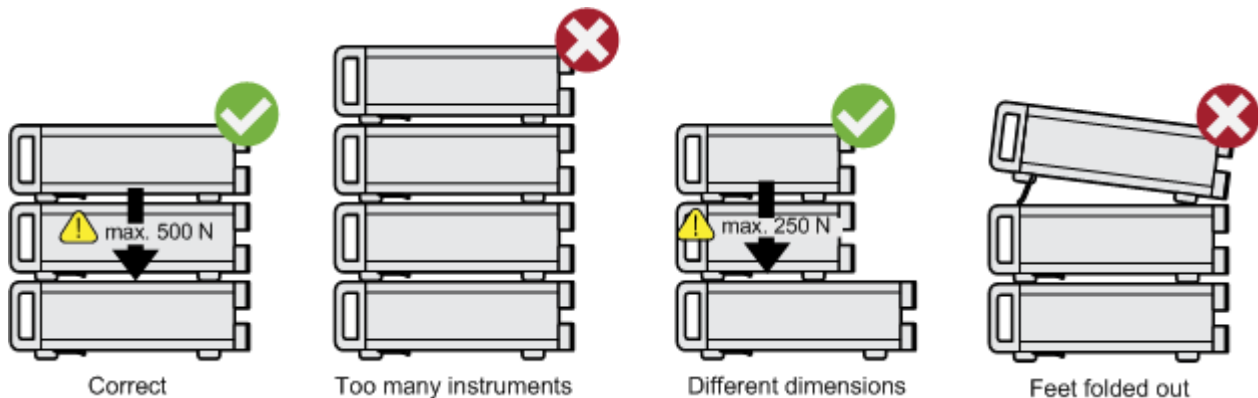
**⚠ WARNING****Risk of injury if feet are folded out**

The feet can fold in if they are not folded out completely or if the instrument is shifted. Collapsing feet can cause injury or damage the instrument.

- Fold the feet completely in or out to ensure stability of the instrument. Never shift the instrument when the feet are folded out.
- When the feet are folded out, do not work under the instrument or place anything underneath.
- The feet can break if they are overloaded. The overall load on the folded-out feet must not exceed 500 N.

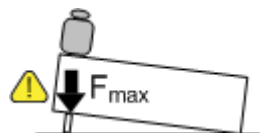

### Rackmounting

The R&S ESW can be installed in a rack using a rack adapter kit (order no. see data sheet). The installation instructions are part of the adapter kit.

#### NOTICE

##### Risk of instrument damage due to insufficient airflow in a rack

If the instrument is run with insufficient airflow for a longer period, the instrument overheats, which can disturb the operation and even cause damage.

Make sure that all fan openings are unobstructed, that the airflow perforations are unimpeded, and that the minimum distance from the wall is 10 cm.

### 2.1.4 Connecting the AC Power

In the standard version, the R&S ESW is equipped with an AC power supply connector. The R&S ESW can be used with different AC power voltages and adapts itself automatically to it. Refer to the datasheet for the requirements of voltage and frequency. The AC power connector is located on the rear panel of the instrument.

For details on the connector refer to [Chapter 3.2.2, "AC Power Connector and Main Power Switch"](#), on page 50.



- ▶ Connect the R&S ESW to the AC power supply using the supplied power cable. Since the instrument is assembled in line with the specifications for safety class EN61010, it may only be connected to an outlet that has a ground contact.

### 2.1.5 Switching the Instrument On and Off

#### Switching the instrument on

- ▶ Press the AC power switch on the rear panel to position "I".

The instrument is supplied with AC power. After booting, the instrument is ready for operation. A green LED above the [POWER] key indicates this.

An orange LED indicates the instrument is in standby mode



#### Warm-up time for OCXO

When the instrument is switched on, the OCXO requires an extended warm-up time (see data sheet).

#### Switching the instrument off

1. Press the [POWER] key on the front panel.

The R&S ESW switches to standby mode.

2. Set the AC power switch on the rear panel to position "O", or disconnect the instrument from the AC power supply.

The R&S ESW changes into off mode.

---

**NOTICE****Risk of losing data**

If you switch off the running instrument using the rear panel switch or by disconnecting the power cord, the instrument loses its current settings. Furthermore, program data can be lost.

Press the Power key first to shut down the application properly.

---

## 2.1.6 Performing a Self-Alignment and a Selftest



During instrument start, the installed hardware is checked against the current firmware version to ensure the hardware is supported. If not, an error message is displayed ("WRONG\_FW") and you are asked to update the firmware. Until the firmware version is updated, self-alignment fails.

(For details refer to the R&S ESW User Manual).

Furthermore, it may be necessary to align the data to a reference source by performing a self-alignment when strong temperature changes occur.

**Operating temperature**

Before performing this functional test, make sure that the instrument has reached its operating temperature (for details, refer to the data sheet).

A message in the status bar ("Instrument warming up...") indicates that the operating temperature has not yet been reached.

**Performing a self-alignment**

1. Press the [SETUP] key.
2. Press the "Alignment" softkey.
3. Select the "Start Self-Alignment" button in the "Alignment" dialog box.

Once the system correction values have been calculated successfully, a message is displayed.

**To display the alignment results again later**

- Press the [SETUP] key.
  - Press the "Alignment" softkey.
-

### Performing a selftest

The selftest does not need to be repeated every time the instrument is switched on. It is only necessary when instrument malfunction is suspected.

1. Press the [SETUP] key.
2. Press the "Service" softkey.
3. Switch to the "Selftest" tab in the "Service" dialog box.
4. Select the "Start Selftest" button.

Once the instrument modules have been checked successfully, a message is displayed.

### 2.1.7 Checking the Supplied Options

The instrument may be equipped with both hardware and firmware options. In order to check whether the installed options correspond to the options indicated on the delivery note, proceed as follows.

1. Press the [SETUP] key.
2. Press the "System Config" softkey.
3. Switch to the "Versions + Options" tab in the "System Configuration" dialog box.  
A list with hardware and firmware information is displayed.
4. Check the availability of the hardware options as indicated in the delivery note.

## 2.2 Windows Operating System

The instrument contains the Microsoft Windows operating system which has been configured according to the instrument's features and needs. Changes in the system setup are only required when peripherals like keyboard or a printer are installed or if the network configuration does not comply with the default settings. After the R&S ESW is started, the operating system boots and the instrument firmware is started automatically.

To ensure that the instrument software functions properly, certain rules must be adhered to concerning the operating system.



**NOTICE****Risk of rendering instrument unusable**

The instrument is equipped with the Microsoft Windows operating system. You can install additional software on the instrument, however, additional software can impair instrument function. Thus, run only programs that Rohde & Schwarz has tested for compatibility with the instrument software.

The drivers and programs used on the instrument under Microsoft Windows are adapted to the instrument. Only install update software released by Rohde & Schwarz to modify existing instrument software.

The following program packages have been tested:

- Symantec Endpoint Security – virus-protection software
- FileShredder - for reliable deletion of files on the hard disk

### 2.2.1 Virus Protection

Take appropriate steps to protect your instruments from infection. Use strong firewall settings and scan any removable storage device used with a Rohde & Schwarz instrument regularly. It is also recommended that you install anti-virus software on the instrument. Rohde & Schwarz does NOT recommend running anti-virus software in the background ("on-access" mode) on Windows-based instruments, due to potentially degrading instrument performance. However, Rohde & Schwarz does recommend running it during non-critical hours.

For details and recommendations, see the following Rohde & Schwarz white paper:

- [1DC01: Malware Protection Windows 7](#)

### 2.2.2 Service Packs and Updates

Microsoft regularly creates security updates and other patches to protect Windows-based operating systems. These are released through the Microsoft Update website and associated update server. Instruments using Windows, especially those that connect to a network, should be updated regularly.

For details and recommendations, see the Rohde & Schwarz White Paper [1DC01: Malware Protection Windows 7](#).

### 2.2.3 Login

Microsoft Windows requires that users identify themselves by entering a user name and password in a login window. By default, the R&S ESW provides two user accounts:

- **"Instrument"**: an administrator account with unrestricted access to the computer/domain

- **"NormalUser"**: a standard user account with limited access

Some administrative tasks require administrator rights (e.g. the configuration of a LAN network). Refer to the description of the basic instrument setup ([SETUP] menu) to find out which functions are affected.



### Secure user mode

If the secure user mode option (R&S ESW-K33) is installed, an additional account is provided: the **"SecureUser"**.

The "SecureUser" is a standard user account with limited functionality. In particular, administrative tasks such as LAN configuration or general instrument settings are not available. Furthermore, for a "SecureUser", data that the R&S ESW normally stores on the solid-state drive is redirected to volatile memory instead. You can access data that is stored in volatile memory during the current instrument session. However, when the instrument's power is removed, all data in volatile memory is erased.

For details, see [Chapter 2.7, "Protecting Data Using the Secure User Mode"](#), on page 37.

---

### Automatic login

For the administrator account, an automatic login function is active by default. If activated, login is carried out automatically for the administrator (with full access) in the background when the R&S ESW is started, without having to enter a password. This function is active until you explicitly deactivate it or change the password.

For information on how to deactivate or reactivate the automatic login, refer to [Chapter 2.2.3.1, "Automatic Login Function"](#), on page 27.

### Passwords

For all default user accounts, the initial password is *894129*. Note that this password is very weak, and it is recommended that you change the password for both users after initial login.

You can change the password in Microsoft Windows for any user at any time via "Start > Control Panel > User Accounts".

When the secure user mode is activated the first time after installation, the user is prompted to change the passwords for all user accounts to improve system security.



### Changing the password and use of auto-login function

Note that when you change the default passwords, the default auto-login function no longer works! Reactivate it manually as described in ["Reactivating the automatic login function"](#) on page 28.

---

#### 2.2.3.1 Automatic Login Function

When shipped, the instrument automatically logs on the default "Instrument" user to Microsoft Windows using the default password.

### Switching users when using the automatic login function

Which user account is used is defined during login. If automatic login is active, the login window is not displayed. However, you can also switch the user account to be used when the automatic login function is active.



1. Select the "Windows" icon in the toolbar to access the operating system of the R&S ESW (see also [Chapter 2.2.4, "Accessing the Start Menu"](#), on page 29).
2. In the "Start" menu, select the arrow next to the "Shut down" button and then "Log off".

The "Login" dialog box is displayed, in which you can enter the different user account name and password.

### Deactivating the automatic login function

To deactivate the automatic login function, perform the following steps:



1. Select the "Windows" icon in the toolbar to access the operating system of the R&S ESW (see also [Chapter 2.2.4, "Accessing the Start Menu"](#), on page 29).
2. In the "Start" menu, select "Run".  
The "Run" dialog box is displayed.
3. Enter the command `C:\R_S\Instr\User\NO_AUTOLOGIN.REG`.
4. Press the [ENTER] key to confirm.  
This command deactivates the automatic login function. The next time you switch on the instrument, the operating system prompts you to enter your user name and password before it starts the firmware.

### Adapting the automatic login function to a new password

If you change the "Instrument" user's password, which is used during automatic login, this function no longer works. Adapt the settings for the command that activates the auto login function first.

1. Open the `C:\R_S\Instr\User\NO_AUTOLOGIN.REG` file in any text editor (e.g. Notepad).
2. In the line `"DefaultPassword"="894129"`, replace the default password (894129) by the new password for automatic login.
3. Save the changes to the file.

### Reactivating the automatic login function



1. Select the "Windows" icon in the toolbar to access the operating system of the R&S ESW (see also [Chapter 2.2.4, "Accessing the Start Menu"](#), on page 29).
2. In the "Start" menu, select "Run".  
The "Run" dialog box is displayed.
3. Enter the command `C:\R_S\Instr\User\AUTOLOGIN.REG`.

4. Press the [ENTER] key to confirm.  
This command reactivates automatic login function. It is active the next time the instrument reboots.

## 2.2.4 Accessing the Start Menu

The Windows "Start" menu provides access to the Microsoft Windows functionality and installed programs.

To open the "Start" menu:



- ▶ In Windows 7:  
Select the "Windows" icon on the R&S ESW toolbar, or press the "Windows" key or the [CTRL + ESC] key combination on the (external) keyboard.

All necessary system settings can be defined in the "Start > Control Panel" menu (for required settings refer to the Microsoft Windows documentation and to the hardware description).

## 2.2.5 Accessing the Windows Taskbar

The Windows taskbar also provides quick access to commonly used programs, for example Paint or WordPad. IECWIN, the auxiliary remote control tool provided free of charge and installed by Rohde & Schwarz, is also available from the taskbar.



For details on the IECWIN tool, see the "Network and Remote Control" chapter of the R&S ESW user manual.



To open the taskbar, select the "Windows" icon on the R&S ESW toolbar, or press the "Windows" key or the [CTRL + ESC] key combination on your (external) keyboard.

## 2.3 Connecting USB Devices

The USB interfaces of the R&S ESW allow you to connect USB devices directly to the instrument. Increase the number of possible connections using USB hubs. Due to the large number of available USB devices, there is almost no limit to the expansions that are possible with the R&S ESW.

The following list shows various USB devices that can be useful:

- Memory stick for easy transfer of data to/from a computer (e.g. firmware updates)
- CD-ROM drives for easy installation of firmware applications
- Keyboard or mouse to simplify the entry of data, comments, filenames, etc.
- Printer for printing measurement results

Installing USB devices is easy under Windows, because all USB devices are plug&play. After a device is connected to the USB interface, the operating system automatically searches for a suitable device driver.

If Windows does not find a suitable driver, it prompts you to specify a directory that contains the driver software. If the driver software is on a CD, connect a USB CD-ROM drive to the instrument before proceeding.

When a USB device is then disconnected from the R&S ESW, Windows immediately detects the change in hardware configuration and deactivates the corresponding driver.

All USB devices can be connected to or disconnected from the instrument during operation.

### **Connecting a memory stick or CD-ROM drive**

If installation of a memory stick or CD-ROM drive is successful, Windows informs you that the device is ready to use. The device is made available as a new drive and is displayed in Windows Explorer. The name of the drive depends on the manufacturer.

### **Connecting a keyboard**

The keyboard is detected automatically when it is connected. The default input language is English – US.

However, you can also connect foreign language keyboards; currently the following languages are supported for the R&S ESW:

- German
- Swiss
- French
- Russian

Select "Start > Control Panel > Clock, Language, and Region > Change keyboards or other input methods" to configure the keyboard properties. To access the Windows operating system, press the Windows key on the external keyboard.

### **Connecting a mouse**

The mouse is detected automatically when it is connected.

Select "Start > Control Panel > Devices and Printers > Mouse" to configure the mouse properties. To access the Windows operating system, press the Windows key on the external keyboard.

### **Connecting a printer**

When printing a file, the instrument checks whether a printer is connected and turned on and whether the appropriate printer driver is installed. If necessary, printer driver installation is initiated. You only have to install a printer driver once.

To install a printer, select "Start > Control Panel > Devices and Printers > Add a printer". To access the Windows operating system, press the Windows key on the external keyboard.

You can load updated and improved driver versions or new drivers from an installation disk, USB memory stick or another external storage medium. If the instrument is integrated in a network, you can also install driver data stored in a network directory.

Select "Start > Control Panel > Devices and Printers > Device Manager > Update Device drivers" to install the driver.

## 2.4 Connecting an External Monitor

You can connect an external monitor (or projector) to the DVI or display port connector on the instrument's rear panel.

(See also [Chapter 3.2.3, "DisplayPort and DVI"](#), on page 51).



### Screen resolution and format

The touchscreen of the R&S ESW is calibrated for a 16:10 format. If you connect a monitor or projector using a different format (e.g. 4:3), the calibration will not be correct and the screen will not react to your touch actions properly.

The touchscreen has a screen resolution of 1280x800 pixels. Most external monitors have a higher screen resolution. If the screen resolution of the monitor is set higher than the instrument's resolution, the application window uses an area of 1280x800 pixels on the monitor display. For full screen display, adjust the monitor's screen resolution.

The R&S ESW supports a minimum resolution of 1280x768 pixels.

---

1. Connect the external monitor to the R&S ESW.
2. Press the [SETUP] key.
3. Press the "Display" softkey.
4. Select the "Configure Monitor" tab in the "Display" dialog box.  
The standard Windows "Screen Resolution" dialog box is displayed.

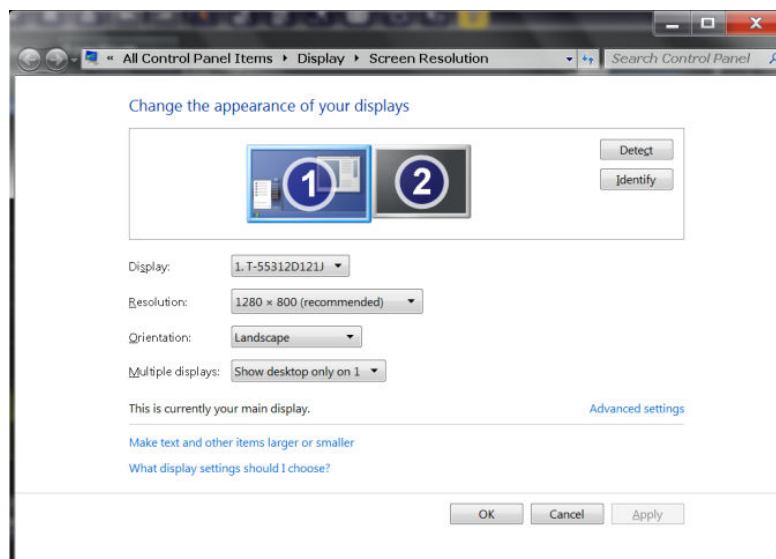

5. If necessary, change the screen resolution to be used. Consider the information in the note above.
6. Select the instrument to be used for display:
  - "Display 1": internal monitor only
  - "Display 2": external monitor only
  - "Duplicate": both internal and external monitor
7. Tap "Apply" to try out the settings before they are accepted permanently, then you can easily return to the previous settings, if necessary.
8. Select "OK" if the settings are suitable.

## 2.5 Setting Up a Network (LAN) Connection

A LAN connection is the prerequisite for all network operations. The LAN connection settings can be configured directly in the Windows operating system.

The R&S ESW is equipped with a network interface and can be connected to an Ethernet LAN (local area network). Provided the network administrator has assigned you the appropriate rights and adapted the Windows firewall configuration, you can use the interface, for example:

- To transfer data between a controlling device and the test device, e.g. to run a remote control program.  
See chapter "Remote Control".
- To access or control the measurement from a remote computer using the "Remote Desktop" application (or a similar tool)
- To connect external network devices (e.g. printers)
- To transfer data from a remote computer and back, e.g. using network folders

This section describes how to configure the LAN interface. It includes the following topics:

- [Chapter 2.5.1, "Connecting the Instrument to the Network"](#), on page 33
- [Chapter 2.5.2, "Assigning the IP Address"](#), on page 34

Note that only user accounts with administrator rights can configure LAN networks.



### LXI

The R&S ESW supports the LXI core features. LXI gives you direct access to the LAN settings described below.

---

For further information on the LXI interface, refer to [Chapter 12.4.4, "LXI Settings"](#), on page 393.

## 2.5.1 Connecting the Instrument to the Network

There are two methods to establish a LAN connection to the instrument:

- A non-dedicated network (Ethernet) connection from the instrument to an existing network made with an ordinary RJ-45 network cable. The instrument is assigned an IP address and can coexist with a computer and with other hosts on the same network.
- A dedicated network connection (Point-to-point connection) between the instrument and a single computer made with a (crossover) RJ-45 network cable. The computer must be equipped with a network adapter and is directly connected to the instrument. The use of hubs, switches, or gateways is not required, however, data transfer is still performed using the TCP/IP protocol. You must assign an IP address to the instrument and the computer, see [Chapter 2.5.2, "Assigning the IP Address"](#), on page 34.

**Note:** As the R&S ESW uses a 1 GBit LAN, a crossover cable is not necessary (due to Auto-MDI(X) functionality).

---

### NOTICE

#### Risk of network failure

Consult your network administrator before performing the following tasks:

- Connecting the instrument to the network
- Configuring the network
- Changing IP addresses
- Exchanging hardware

Errors can affect the entire network.

---

- ▶ To establish a non-dedicated network connection, connect a commercial RJ-45 cable to one of the LAN ports.



To establish a dedicated connection, connect a (crossover) RJ-45 cable between the instrument and a single PC.

If the instrument is connected to the LAN, Windows automatically detects the network connection and activates the required drivers.

The network card can be operated with a 1 GBit Ethernet IEEE 802.3u interface.

## 2.5.2 Assigning the IP Address

Depending on the network capacities, the TCP/IP address information for the instrument can be obtained in different ways.

- If the network supports dynamic TCP/IP configuration using the Dynamic Host Configuration Protocol (DHCP), all address information can be assigned automatically.
- If the network does not support DHCP, or if the instrument is set to use alternate TCP/IP configuration, the addresses must be set manually.

By default, the instrument is configured to use dynamic TCP/IP configuration and obtain all address information automatically. This means that it is safe to establish a physical connection to the LAN without any previous instrument configuration.

---

### NOTICE

#### Risk of network errors

Connection errors can affect the entire network. If your network does not support DHCP, or if you choose to disable dynamic TCP/IP configuration, you must assign valid address information before connecting the instrument to the LAN. Contact your network administrator to obtain a valid IP address.

---

#### Assigning the IP address on the instrument

1. Press the [SETUP] key.
2. Press the "Network + Remote" softkey.
3. Select the "Network" tab.
4. In the "Network + Remote" dialog, toggle the "DHCP On/Off" setting to the required mode.

If DHCP is "Off", you must enter the IP address manually, as described in the following steps.

**Note:** When DHCP is changed from "On" to "Off", the previously set IP address and subnet mask are retrieved.

If DHCP is "On", the IP address of the DHCP server is obtained automatically. The configuration is saved, and you are prompted to restart the instrument. You can skip the remaining steps.

**Note:** When a DHCP server is used, a new IP address may be assigned each time the instrument is restarted. This address must first be determined on the instrument

itself. Thus, when using a DHCP server, it is recommended that you use the permanent computer name, which determines the address via the DNS server (See ["Using a DNS server to determine the IP address"](#) on page 35 and [Chapter 2.5.3, "Using Computer Names"](#), on page 36).

5. Enter the "IP Address", for example *192.0.2.0*. The IP address consists of four number blocks separated by dots. Every block contains a maximum of 3 numbers.
6. Enter the "Subnet Mask", for example *255.255.255.0*. The subnet mask consists of four number blocks separated by dots. Every block contains a maximum of 3 numbers.
7. Select "Configure Network".  
If you have entered an invalid IP address or subnet mask, the message "out of range" is displayed in the status line. If the settings are correct, the configuration is saved, and you are prompted to restart the instrument.
8. Confirm the displayed message ("Yes" button) to restart the instrument.

#### **Using a DNS server to determine the IP address**

If a DNS server is configured on the R&S ESW, the server can determine the current IP address for the connection using the permanent computer name.

1. Obtain the name of your DNS domain and the IP addresses of the DNS and WINS servers on your network.
2. Press the [Setup] key and then the "Network + Remote" softkey.
3. In the "Network" tab, select the "Open Dialog 'Network Configuration'" button.
4. Double-tap the "Local Area Connection" icon.
5. In the "Local Area Connection Status" dialog box, select the "Properties" button.  
The items used by the LAN connection are displayed.
6. Tap the entry named "Internet Protocol Version 4 (TCP/IPv4)" to highlight it.

Setting Up a Network (LAN) Connection

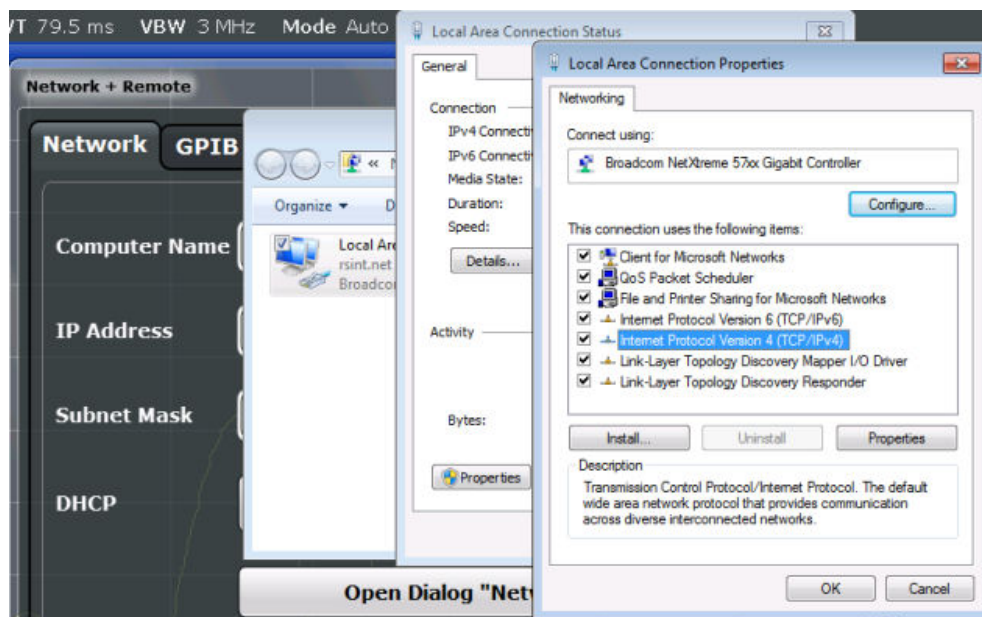

7. Select the "Properties" button.
8. On the "General" tab, select "Use the following DNS server addresses" and enter your own DNS addresses.

For more information, refer to the Windows operating system Help.

### 2.5.3 Using Computer Names

In a LAN that uses a DNS server (Domain Name System server), each PC or instrument connected in the LAN can be accessed via an unambiguous computer name instead of the IP address. The DNS server translates the host name to the IP address. This is especially useful when a DHCP server is used, as a new IP address may be assigned each time the instrument is restarted.

Each instrument is delivered with an assigned computer name, but this name can be changed.

The default instrument name is a non-case-sensitive string with the following syntax:

<Type><variant>-<serial\_number>

The serial number can be found on the rear panel of the instrument. It is the third part of the device ID printed on the bar code sticker:



For example, ESW26-123456

### To change the computer name

1. Press the [Setup] key and then the "Network + Remote" softkey.  
The current "Computer Name" is displayed in the "Network" tab.
2. Enter the new computer name.
3. Close the dialog box.

## 2.5.4 Changing the Windows Firewall Settings

A firewall protects an instrument by preventing unauthorized users from gaining access to it through a network. Rohde & Schwarz highly recommends the use of the firewall on your instrument. Rohde & Schwarz instruments are shipped with the Windows firewall enabled and preconfigured in such a way that all ports and connections for remote control are enabled.

For more details on firewall configuration, see the following Rohde & Schwarz White Paper:

- [1DC01: Malware Protection Windows 7](#)

Note that changing firewall settings requires administrator rights.

## 2.6 Setting the Date and Time

Users with administrator rights can set the date and time for the internal real time clock as follows:

### Opening the Date and Time Properties dialog box

1. Press the [SETUP] key.
2. Press the "Display" softkey.
3. Select the "General" tab in the "Display" dialog box.
4. Press the "Set Date and Time" button to open the standard Windows "Date and Time Properties" dialog box.
5. If necessary, toggle the "Date and Time Format" between German (DE) and US.

After you have made a change and closed the dialog box, the new date and time is also adopted by the instrument.

## 2.7 Protecting Data Using the Secure User Mode

During normal operation, the R&S ESW uses a solid-state drive to store its operating system, instrument firmware, instrument self-alignment data, and any user data cre-

ated during operation. If necessary, the solid-state drive can be removed from the R&S ESW and locked in a secure place to protect any classified data it may contain.

### Redirecting storage to volatile memory

Alternatively, to avoid storing any sensitive data on the R&S ESW permanently, the *secure user mode* was introduced (option R&S ESW-K33). In secure user mode the instrument's solid-state drive is write-protected so that no information can be written to memory permanently. Data that the R&S ESW normally stores on the solid-state drive is redirected to volatile memory instead, which remains available only until the instrument is switched off. This data includes:

- Windows operating system files
- Firmware shutdown files containing information on last instrument state
- Self-alignment data
- General instrument settings such as the IP address
- Measurement settings
- User data created during operation (see also [Table 10-1](#))
- Any data created by other applications installed on the R&S ESW, for example text editors (Notepad), the Clipboard, drawing tools, etc.

Users can access data that is stored in volatile memory just as in normal operation. However, when the instrument's power is switched off, all data in this memory is cleared. Thus, in secure user mode, the instrument always starts in a defined, fixed state when switched on.

To store data such as measurement results permanently, it must be stored to an external storage device, such as a memory stick.



### Limited storage space

The volatile memory used to store data in secure user mode is restricted to 256 MB. Thus, a "Memory full" error can occur although the hard disk indicates that storage space is still available.

---

### Storing required data permanently

Any data that is to be available for subsequent sessions with the R&S ESW must be stored on the instrument permanently, *before activating the secure user mode*. This includes predefined instrument settings, transducer factors and self-alignment data.

---



### Self-alignment data

Note that self-alignment data becomes invalid with time and due to temperature changes. Therefore, to achieve optimal accuracy, it may be preferable to perform a new self-alignment at the start of each new session on the R&S ESW.

---

### Restricted operation

Since permanent storage is not possible, the following functions are not available in secure user mode:

- Firmware update
- Activating a new option key

Furthermore, since the "SecureUser" used in secure user mode does not have administrator rights, **administrative tasks** such as LAN configuration and some general instrument settings are not available. Refer to the description of the basic instrument setup ([SETUP] menu) to find out which functions are affected.

### Activating and deactivating secure user mode

Only a user with administrator rights can activate the secure user mode. Once activated, a restart is required. The special user "SecureUser" is then logged on to the R&S ESW automatically using the automatic login function. While the secure user mode is active, a message is displayed in the status bar at the bottom of the screen.



#### Secure Passwords

By default, the initial password for both the administrator account ("Instrument") and the "SecureUser" account is "894129". When the secure user mode is activated the first time after installation, you are prompted to change the passwords for all user accounts to improve system security. Although it is possible to continue without changing the passwords, it is strongly recommended that you do so.

You can change the password in Microsoft Windows for any user at any time via "Start > Control Panel > User Accounts".

---

To deactivate the secure user mode, the "SecureUser" must log off and the "Instrument" user (administrator) must log on.



#### Switching users when using the automatic login function

In the "Start" menu, select the arrow next to the "Shut down" button and then "Log off". The "Login" dialog box is displayed, in which you can enter the different user account name and password.

---

The secure user mode setting and automatic login is automatically deactivated when the "Instrument" user logs on. The "SecureUser" is no longer available.

For administrators ("Instrument" user), the secure user mode setting is available in the general system configuration settings (see "[SecureUser Mode](#)" on page 328).

### Remote control

Initially after installation of the R&S ESW-K33 option, secure user mode must be enabled manually once before remote control is possible.

(See `SYSTEM:SECURITY[:STATe].`)

This is necessary to prompt for a change of passwords.

## 3 Instrument Tour

On the instrument tour, you can learn about the different control elements and connectors on the front and back panel of the R&S ESW.

### 3.1 The Front Panel

The front panel contains the main control elements of the R&S ESW in addition to various connectors as shown in [Figure 3-1](#).

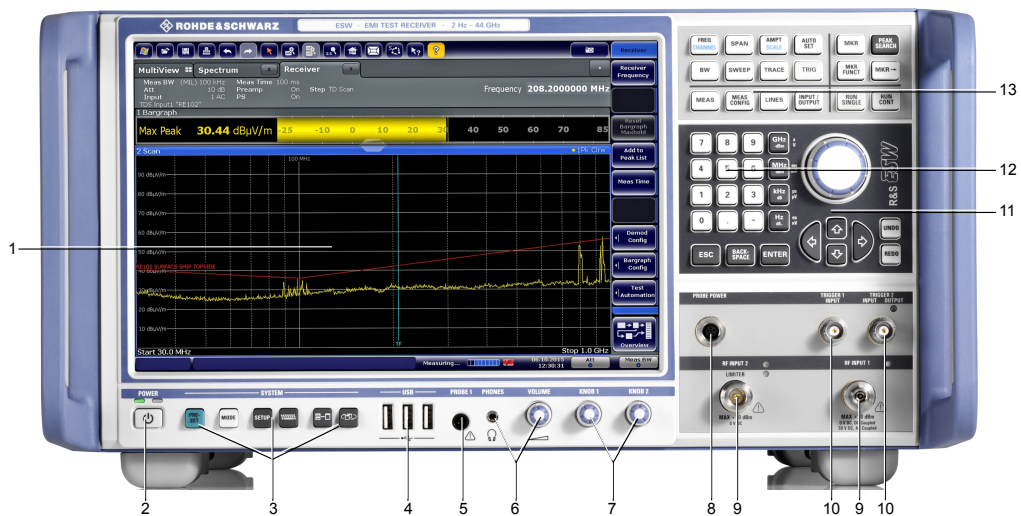

**Figure 3-1: Front panel of the R&S ESW**

- 1 = Display (touchscreen)
- 2 = Power key
- 3 = System control keys
- 4 = USB ports
- 5 = Probe power connector
- 6 = Headphone jack and volume control
- 7 = Fast access knobs
- 8 = Probe power connector
- 9 = Radiofrequency (RF) inputs
- 10 = Trigger in- and outputs
- 11 = Navigation controls
- 12 = Alphanumeric keys
- 13 = Configuration keys

**NOTICE****Instrument damage caused by cleaning agents**

Cleaning agents contain substances such as solvents (thinners, acetone, etc.), acids, bases, or other substances. Solvents can damage the front panel labeling, plastic parts, or screens, for example.

Never use cleaning agents to clean the outside of the instrument. Use a soft, dry, lint-free dust cloth instead.

### 3.1.1 Display (Touchscreen)

The touchscreen on the front panel of the R&S ESW displays the measurement results. Additionally, the screen display provides status and setting information and allows you to switch between various measurement tasks. The screen is touch-sensitive, offering an alternative means of user interaction for quick and easy handling of the instrument.

**NOTICE****Risk of touchscreen damage**

Inappropriate tools or excessive force can damage the touchscreen.

Observe the following instructions when operating the touchscreen:

- Never touch the screen with ball point pens or other sharp objects, use your fingers instead.  
As an alternative, you can use a stylus pen with a smooth soft tip.
- Never apply excessive force to the screen. Touch it gently.
- Never scratch the screen surface, for example with a finger nail.
- Never rub the screen surface strongly, for example with a dust cloth.  
For instructions on cleaning the screen, see [Chapter 14.1, "Cleaning"](#), on page 711.



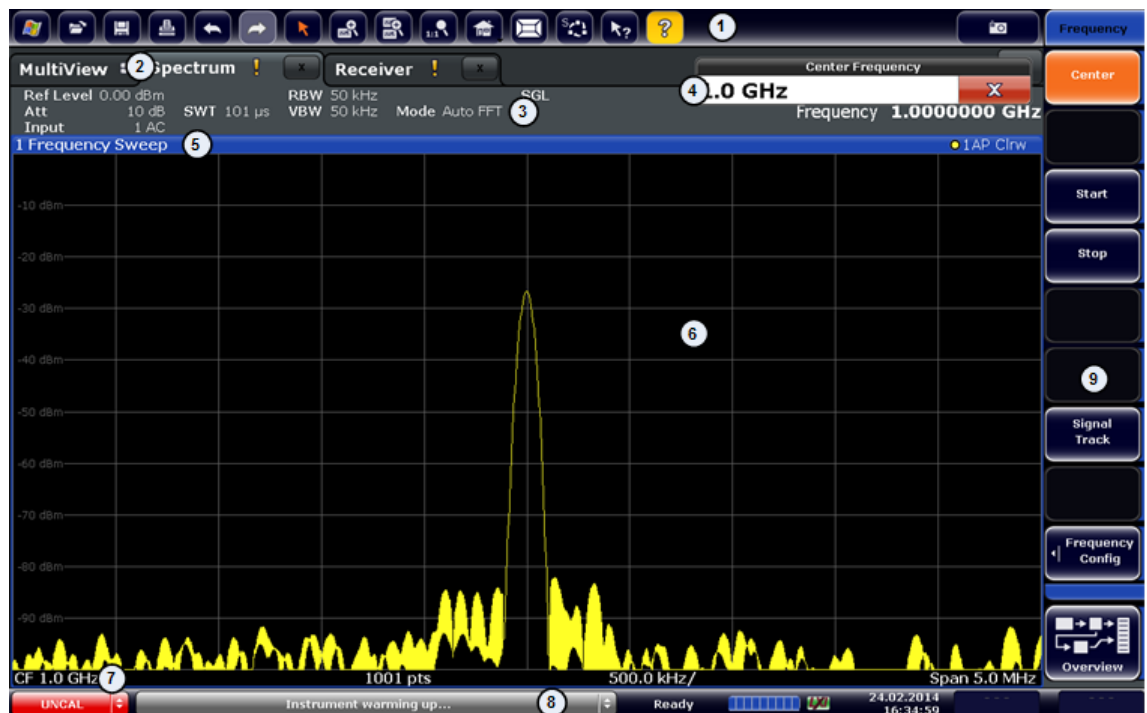

- 1 = Toolbar: contains general functionality of the firmware (print, save etc.).
- 2 = Channel tabs: each tab contains a measurement channel.
- 3 = Channel bar: shows measurement settings and allows you to change those settings easily.
- 4 = Input field.
- 5 = Window title bar: contains diagram-specific (trace) information.
- 6 = Result display: contains the measurement results.
- 7 = Diagram footer: contains diagram-specific information.
- 8 = Status bar: contains system messages, progress bar and date and time.
- 9 = Softkeys: provide access to measurement functions.

A touchscreen is a screen that is touch-sensitive, i.e. it reacts in a specified way when a particular element on the screen is tapped by a finger or a pointing device, for example. Any user interface elements that can be clicked on by a mouse pointer can also be tapped on the screen to trigger the same behavior, and vice versa.

Using the touchscreen, the following tasks (among others) can be performed by the tap of your finger:

- Changing a setting
- Changing the display
- Moving a marker
- Zooming into a diagram
- Selecting a new evaluation method
- Scrolling through a result list
- Saving or printing results and settings

To imitate a right-click by mouse using the touchscreen, for example to open a context-sensitive menu for a specific item, press the screen for about 1 second.

### 3.1.2 Power Key

The Power key on the front panel turns the instrument on and off.







	<p>The color of the LED above the key shows its current state.</p> <ul style="list-style-type: none"> <li>• Orange: instrument is in stand-by mode.</li> <li>• Green: instrument is running.</li> </ul>
---	---

For more information see [Chapter 2.1.5, "Switching the Instrument On and Off"](#), on page 23.

### 3.1.3 System Control Keys

System control keys provide access to the basic instrument configuration.

Please refer to the User Manual for an extensive description of the system configuration functionality.

	<p>Resets the instrument to its default configuration.</p>
	<p>Selects a particular measurement application or operating mode.</p>
	<p>Provides functionality to configure basic instrument characteristics, for example:</p> <ul style="list-style-type: none"> <li>• the LAN connection</li> <li>• the date and time</li> <li>• the display configuration</li> <li>• the reference frequency</li> <li>• firmware update and application installation</li> <li>• service functions</li> <li>• transducer configuration</li> <li>• configuration of the Fast Access panel</li> </ul>
	<p>Provides access to the on-screen keyboard.</p>
	<p>Turns full screen mode on and off.</p>
	<p>Selects a window in split screen mode or browses through active windows in split screen mode.</p>

### 3.1.4 USB Ports

The three USB ports on the front panel (type A) allow you to connect devices like keyboards, mice or memory sticks.



The R&S ESW provides additional USB ports (including one type B port) on the rear panel.

All USB ports support standard 2.0.

### 3.1.5 Probe Power Connector (3 and 5 Pins)

The R&S ESW provides two connectors to supply accessories that require a power supply (for example probes or transducers).

The probe power connector with five pins supports supply voltages of  $\pm 10$  V and ground. The maximum permissible current is 200 mA. This probe power connector is suitable, for example, for transducers from Rohde & Schwarz.

The probe power connector with three pins supports supply voltages from +15 V to -12.6 V and ground. The maximum permissible current is 150 mA. This probe power connector is suitable, for example, for high-impedance probes from Agilent.

### 3.1.6 Headphone Jack and Volume Control

The female headphone jack allows you to connect headphones (or external speakers) with a miniature jack plug.

You can control the output voltage with the volume control next to the headphone jack.

If you connect headphones or external speakers, the R&S ESW automatically turns off the internal speaker.



#### Muting sound

You can turn the volume on and off easily by pressing the volume control.

#### CAUTION

##### Risk of hearing damage

Before putting on the headphones, make sure that the volume setting is not too high to protect your hearing.

### 3.1.7 Fast Access Knobs

The two knobs on the front panel are designed to provide fast access to a (predefined) set of settings that you are using regularly, and change these settings without using the user interface. Each knob can carry several different functions.

You can find a comprehensive description of the fast access knobs in the User Manual.

### 3.1.8 RF Inputs (50 $\Omega$ )

The R&S ESW provides two RF inputs for connection of a device under test (DUT) to the R&S ESW. The DUT is connected to the RF Input via cable and an appropriate connector (for example a male N connector).

The first RF Input supports a frequency range from 2 Hz to  $f_{\max}$  and an attenuation range from 0 dB to 75 dB. The second RF Input supports a frequency range from 2 Hz to 1 GHz and an attenuation range from 10 dB to 75 dB. Attenuation levels greater than 10 dB at RF Input 2 are only possible when the pulse limiter is not active (refer to the User Manual for more information).

#### **NOTICE**

##### **Risk of instrument damage**

Do not overload the RF input. For maximum allowed values, see the data sheet.

For AC-coupling, a DC input voltage of 50 V must never be exceeded. For DC-coupling, DC voltage must not be applied at the input. In both cases, noncompliance will destroy the input mixers.

When measuring unknown signals, do not use a 0 dB attenuation level. Otherwise, the input mixer may be damaged or destroyed.

When measuring unknown signals on the second RF input, turn on the pulse limiter feature. Otherwise, the input mixer may be damaged or destroyed in case of high power signals.

### 3.1.9 Trigger Input and Output

The female BNC connector labeled "Trigger Input" allows you to receive an external trigger signal.

The female BNC connector labeled "Trigger Input / Output" allows you to receive an external trigger signal or send a trigger signal to another device.

When you are using the connector as a trigger input, you can apply voltages in the range from 0.5 V to 3.5 V (the default value is 1.4 V). The typical input impedance is 10 k $\Omega$ .

When you are using the connector as a trigger output, the TTL compatible signal is transmitted (0 V / 5 V).

Note that you can find another connector for trigger input and output on the rear panel.

For more information about controlling and configuring trigger input and output, refer to the User Manual.

### 3.1.10 Navigation Control

Navigation control consists of a rotary knob and cursor keys. These keys allow you to navigate within the display or within dialog boxes.

In addition to the rotary knob and the cursor keys, the navigation control also provides undo / redo functionality.

### Rotary knob

The rotary knob allows you to do several things:

- It increases or decreases any kind of numeric value. In most cases, the rotary knob changes numeric values with a fixed step size. Turning it to the right corresponds to an increase, turning it to the left to a decrease of a numeric value.
- It works like a cursor key in dialog boxes or lists (for example dropdown menus). In that case you can navigate to one of the items with the rotary knob. If the dialog box covers more than one screen page, it also scrolls through the dialog box. Turning it to the right corresponds to a downward movement. Moving it to the left to an upward movement.
- It moves around markers and other graphical elements on the screen. In most cases, the step size is fix.
- Pressing the rotary knob has the same effect as pressing the [ENTER] key as it confirms an entry or selection.

### Cursor keys

The cursor keys allow you to do several things:

- The up and down keys increase or decrease any kind of numeric value if an input field is active. The cursor keys change numeric values with a fixed step size.
- The cursor keys navigate through dialog boxes or lists (for example dropdown menus).
- The left and right keys move the cursor in an input field in the corresponding direction.
- The up and down keys move markers around. The step size is fix.
- The cursor keys allow you to navigate to a cell in a table.
- The cursor keys move a scroll bar (vertical or horizontal) in dialog boxes that have one.

### Undo and redo functionality



Reverts the software to an older state by erasing the last change you have applied. The undo function is useful, for example, if you are performing a measurement with several markers and a limit line and accidentally select a different measurement. In this case, a lot of settings would be lost. However, if you press [UNDO] immediately afterwards, the previous status is retrieved.



Reverses an undo action or repeats the most recently performed action.



The [UNDO] function is not available after a [PRESET] or "RECALL" operation. When these functions are used, the history of previous actions is deleted.

### 3.1.11 The Keypad

The alphanumeric keys allow you to enter alphanumeric characters where necessary (for example in dialog boxes or input fields). The keypad containing the alphanumeric keys also provides keys that select a particular unit.



Provide access to numbers and (special) characters.

...



Inserts a decimal point at the cursor position (".").



Changes the sign of a numeric value or inserts a dash character ("-") in case of alphanumeric input.



Selects a particular unit for a numeric value. The labels on and next to the key state the units it selects.

...



Pressing one of the unit keys also completes the entry of a numeric value. Note that in case of level entries (dB, dBm etc.) or dimensionless values, all unit keys have the value "1" as multiplying factor and thus work like the [ENTER] key..



Provides the following functions:

In dialog boxes:

- Closes all kinds of dialog boxes if edit mode is not active.
- Quits edit mode if it is active.
- Selects the "Cancel" button when available.

In "Edit" dialog boxes:

- If data entry has been started, it retains the original value and closes the dialog box.
- If data entry has not been started or has been completed, it closes the dialog box.



Deletes the character to the left of the cursor (if an (alpha)numeric entry has been started already).



Provides the following functions:

- Completes the entry of input made with the alphanumeric keys (numeric or alphanumeric) and accepts the input.  
If you enter a numeric value that has a unit, the [ENTER] key works like the [HZ/DB] key.
- Selects the default or focused element in dialog boxes.

### 3.1.12 The Function Keys

Function keys provide access to the most common measurement settings and functions.

Please refer to the User Manual for an extensive description of the measurement settings and functions.

<b>FREQ CHANNEL</b>	Provides functionality to define frequency parameters, for example: <ul style="list-style-type: none"> <li>the receiver or center frequency</li> <li>the frequency offset</li> </ul>
<b>SPAN</b>	Provides functionality to configure the frequency span.
<b>AMPT SCALE</b>	Provides functionality to configure amplitude or level characteristics, for example: <ul style="list-style-type: none"> <li>the attenuation</li> <li>the input impedance</li> <li>the scale of the level axis</li> <li>the preamplifier</li> </ul>
<b>AUTO SET</b>	Provides functionality to automatically define various parameters like the level or frequency.
<b>BW</b>	Provides functionality to define various filter bandwidths.
<b>SWEEP</b>	Provides functionality to configure the measurement, for example: <ul style="list-style-type: none"> <li>the measurement mode (single or continuous measurements)</li> <li>the number of measurement points</li> <li>the measurement time</li> </ul>
<b>TRACE</b>	Provides functionality to configure data acquisition and analyze measured data, for example: <ul style="list-style-type: none"> <li>the trace mode</li> <li>the detector</li> </ul>
<b>TRIG</b>	Provides functionality to configure triggered and gated measurements.
<b>MKR</b>	Provides functionality to activate and position absolute and relative markers (markers and delta markers).
<b>PEAK SEARCH</b>	Performs a peak search for active markers. If no marker is active, Marker 1 is activated and the peak search is performed for it.
<b>MKR FUNCT</b>	Spectrum application only: Provides additional analysis functions of the measurement markers, for example: <ul style="list-style-type: none"> <li>the frequency counter</li> <li>the noise measurement</li> <li>the phase noise measurement</li> <li>the AM/FM audio demodulator</li> </ul>
<b>MKR →</b>	Provides functionality to position and control markers, for example: <ul style="list-style-type: none"> <li>to configure the marker search</li> <li>to configure the peak excursion</li> </ul>

<b>MEAS</b>	<p>Provides the measurement functions, for example:</p> <ul style="list-style-type: none"> <li>• the bargraph measurement (Receiver application)</li> <li>• the scan and final measurement (Receiver application)</li> <li>• the AF demodulation (Receiver application)</li> <li>• IF analysis</li> <li>• the channel power and ACLR measurement (Spectrum application)</li> <li>• the occupied bandwidth measurement (Spectrum application)</li> <li>• the Spectrum Emission Mask (SEM) measurement (Spectrum application)</li> <li>• the spurious emission measurement (Spectrum application)</li> <li>• the signal statistics (Spectrum application)</li> </ul>
<b>MEAS CONFIG</b>	Provides functionality to configure the measurement.
<b>LINES</b>	Provides functionality to control display and limit lines.
<b>INPUT / OUTPUT</b>	Provides functionality to configure inputs and outputs.
<b>RUN SINGLE</b>	Starts a measurement in single measurement mode.
<b>RUN CONT</b>	Starts a measurement in continuous measurement mode.

## 3.2 The Rear Panel

The rear panel contains various connectors as shown in [Figure 3-2](#).

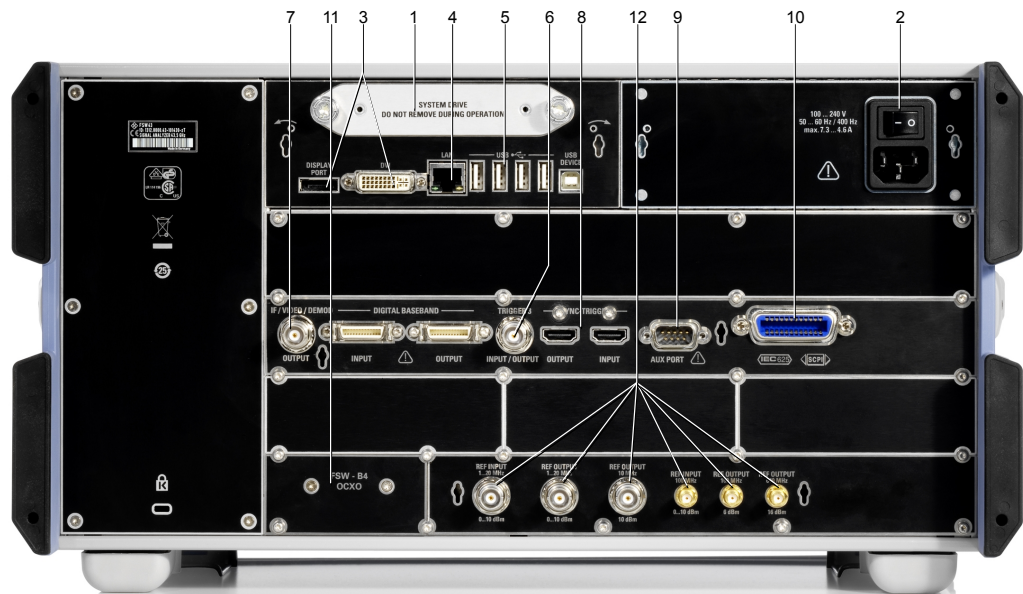

Figure 3-2: Rear panel of the R&S ESW



- 1 = Removable hard drive
- 2 = AC power supply and main power switch
- 3 = DisplayPort and DVI connector
- 4 = LAN connector
- 5 = USB ports
- 6 = Trigger in- and outputs
- 7 = IF / Video / Demod output
- 8 = Sync Trigger input and output
- 9 = AUX port
- 10 = GPIB interface
- 11 = OCXO external reference (option R&S ESW-B4)
- 12 = REF inputs and outputs
- Not shown = External Generator control (option R&S ESW-B10)

- [Removable Hard Disk](#)..... 50
- [AC Power Connector and Main Power Switch](#)..... 50
- [DisplayPort and DVI](#)..... 51
- [LAN Connector](#)..... 51
- [USB Ports](#)..... 51
- [IF / Video / Demod Output](#)..... 51
- [Sync Trigger Input and Output](#)..... 51
- [AUX Port](#)..... 52
- [GPIB Interface](#)..... 52
- [External Generator Control \(Optional\)](#)..... 52
- [OCXO \(Optional\)](#)..... 53
- [REF INPUT / REF OUTPUT](#)..... 53

### 3.2.1 Removable Hard Disk

The removable hard disk is accessible from the rear of the instrument.

In addition to the operating system and the firmware, the R&S ESW also stores measurement data on that disk. When you remove the hard disk, you can store it and the data on it somewhere secure.

### 3.2.2 AC Power Connector and Main Power Switch

The AC power supply and main power switch are located in a unit on the rear panel of the instrument.

The main power switch has the following states.

- Position "1": The instrument is supplied with power.
- Position "0": The instrument is disconnected from the power supply.

For details refer to [Chapter 2.1.5, "Switching the Instrument On and Off"](#), on page 23.

### 3.2.3 DisplayPort and DVI

You can connect an external monitor or other display device to the R&S ESW. Another display device allows you to view the user interface on a bigger screen. Two different types of connectors are provided for this purpose:

- DisplayPort
- DVI (Digital Visual Interface)

For details see [Chapter 2.4, "Connecting an External Monitor"](#), on page 31.

### 3.2.4 LAN Connector

The LAN interface allows you to connect the R&S ESW to a local network for remote control, printouts or data transfer. The assignment of the RJ-45 connector supports twisted-pair category 5 UTP/STP cables in a star configuration (UTP stands for *unshielded twisted pair*, and STP for *shielded twisted pair*).

For details see [Chapter 12, "Network and Remote Operation"](#), on page 344.

### 3.2.5 USB Ports

The four USB ports on the rear panel (type A) allow you to connect devices like keyboards, mice or memory sticks.

The male USB connector (type B) allows you to connect the R&S ESW to a computer and establish a remote control connection, for example.

All USB connectors support standard 2.0.

### 3.2.6 IF / Video / Demod Output

The two female BNC connectors can be used for various outputs:

- Output of the intermediate frequency (IF)
- Output of the video signal
- Output of the demodulated signal (AM, FM)

Details about configuring the output type and characteristics are part of the user manual.

### 3.2.7 Sync Trigger Input and Output

The "Sync Trigger Input / Output" connectors allow you to synchronize several devices (for example two R&S ESWs) with respect to the trigger signal, but also the reference frequency. A 100 MHz signal can be output as a trigger or reference signal to another device, and an external trigger or reference signal can be received at the input connector by the R&S ESW.

### 3.2.8 AUX Port

The 9 pole SUB-D male connector provides control signals for controlling external devices. The voltage levels are TTL compatible (max. 5 V).



Pin	Signal	Description
1	+5 V / max. 250 mA	Supply voltage for external circuits
2	I/O	Controls phase N
3	I/O	Controls the 150 kHz highpass filter
4	I/O	Controls phase L3
5	I/O	not used
6	I/O	Controls phase L1
7	I/O	Controls phase L2
8	GND	Ground
9	READY FOR TRIGGER	Signal indicating that the instrument is ready to receive a trigger signal (Low active = 0 V)

#### NOTICE

##### Short-circuit hazard

Always observe the designated pin assignment. A short-circuit can damage the port.

### 3.2.9 GPIB Interface

The GPIB interface is in compliance with IEEE488 and SCPI. A computer for remote control can be connected via this interface. To set up the connection, a shielded cable is recommended. For more details refer to "Setting Up Remote Control" in the User Manual.

### 3.2.10 External Generator Control (Optional)

The optional "External Generator Control" provides an additional GPIB interface and AUX port.

The GPIB connector can be used to connect an external generator to the R&S ESW.

The AUX port is required for TTL synchronization, if supported by the generator (see [Chapter 3.2.8, "AUX Port"](#), on page 52).

For details on connecting an external generator see the "External Generator Control" section of the R&S ESW User Manual.

### 3.2.11 OCXO (Optional)

This optional OCXO generates a 10 MHz reference signal with a very precise frequency. If installed, and if no external signal is used, this signal is used as an internal reference. It can also be used to synchronize other connected devices via the REF OUTPUT 10 MHz connector.



#### Warm-up time for OCXO

When the instrument is switched on, the OCXO requires an extended warm-up time (see data sheet).

### 3.2.12 REF INPUT / REF OUTPUT

The REF INPUT connectors are used to provide an external reference signal to the R&S ESW.

The REF OUTPUT connectors can be used to provide an external reference signal (or the optional OCXO reference signal) from the R&S ESW to other devices that are connected to this instrument.

Various connectors are provided for different reference signals:

Connector	Reference signal	Usage
REF INPUT	1...20 MHz 0...10 dBm	To provide an external reference signal on the R&S ESW.
REF OUTPUT	1...20 MHz 0...10 dBm	To provide the same external reference signal received by the REF INPUT 1...20 MHz connector to another device, when available.
REF OUTPUT	10 MHz 10 dBm	To provide the internal reference signal from the R&S ESW to another device continuously. Also used to provide OCXO reference signal to another device.
REF INPUT	100 MHz 0...10 dBm	To provide an external reference signal on the R&S ESW.
REF OUTPUT	100 MHz 6 dBm	To provide a 100 MHz reference signal from the R&S ESW to another device.
REF OUTPUT	640 MHz 16 dBm	To provide a 640 MHz reference signal from the R&S ESW to another device.



#### SYNC TRIGGER

The SYNC TRIGGER connector can also be used to synchronize the reference frequency on several devices.

# 4 Operating the Instrument

The following topics provide an overview on how to work with the R&S ESW. They describe what kind of information is displayed in the diagram area, how to interact with the R&S ESW, and how to use the online help.

- [Understanding the Display Information](#)..... 54
- [Accessing Functions](#)..... 62
- [Changing the Focus](#)..... 66
- [Entering Data](#)..... 66
- [Displaying Results](#)..... 68
- [Getting Help](#)..... 76
- [Remote Control](#)..... 78

## 4.1 Understanding the Display Information

The following image shows the default display layout in the receiver application. All different information areas are labeled. They are explained in more detail in the following sections.

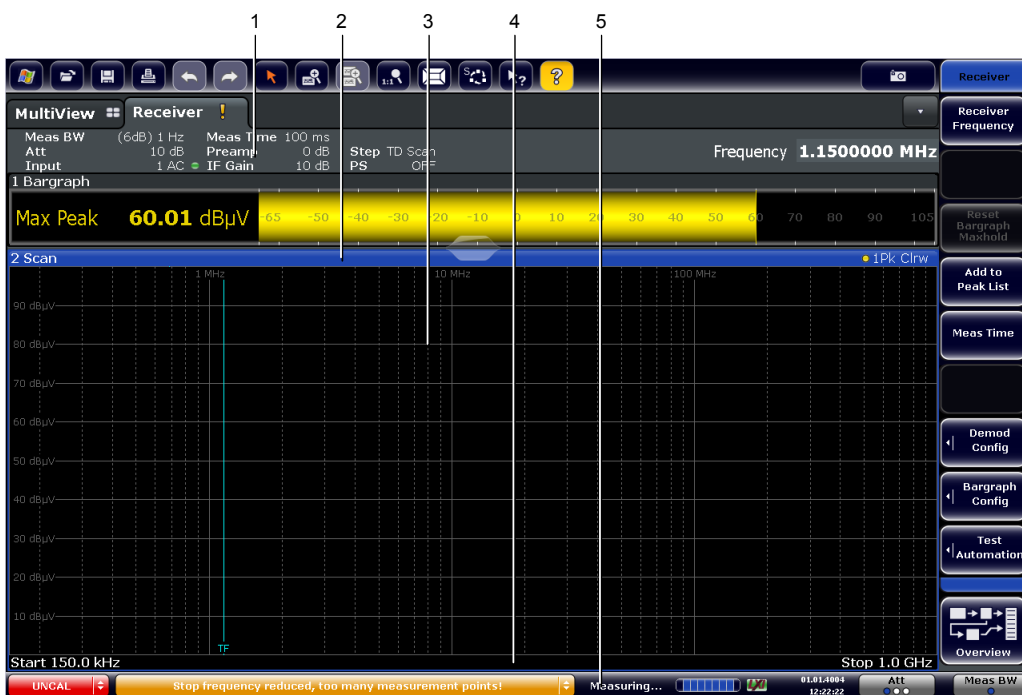

- 1 = Channel bar: shows firmware and measurement settings
- 2 = Window title bar: shows diagram-specific (trace) information
- 3 = Diagram area: contains the measurement results and other information related to the measurement (marker etc.)
- 4 = Diagram footer: shows diagram-specific information, depending on measurement application
- 5 = Instrument status bar: shows error messages, measurement progress, date/time etc.



### Hiding elements in the display

You can hide some of the elements in the display, for example the status bar or channel bar, to enlarge the display area for the measurement results ("Setup" > "Display" > "Displayed Items").

For details, see the R&S ESW user manual.

- [Channel Bar](#)..... 55
- [Window Title Bar](#)..... 57
- [Marker Information](#)..... 58
- [Frequency and Span Information in Diagram Footer](#)..... 59
- [Instrument and Status Information](#)..... 59
- [Error Information](#)..... 60

## 4.1.1 Channel Bar

Using the R&S ESW you can handle several different measurement tasks (channels) at the same time (although they can only be performed asynchronously). For each channel, a separate tab is displayed on the screen. To switch from one channel display to another, simply select the corresponding tab.

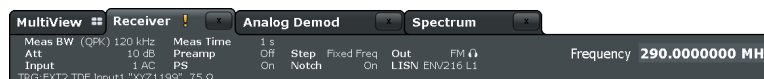

If many tabs are open, you can also select the tab selection list icon at the right end of the channel bar and select the channel you want to see.



### MultiView tab

An additional tab labeled "MultiView" provides an overview of all active channels at a glance. In the "MultiView" tab, each individual window contains its own channel bar with an additional button. Tap this button to switch to the corresponding channel display quickly.

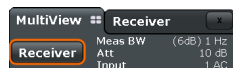

### Icons in the channel bar

The star icon (★) on the tab label indicates that the displayed trace no longer matches the current instrument settings. This can be the case, for example, if a trace is frozen and the instrument settings are changed. When a new measurement is performed, the icon disappears.

The exclamation mark icon (!) indicates that an error or warning is available for that measurement channel. This is particularly useful if the MultiView tab is displayed.

The  icon indicates the currently active channel during an automatic measurement sequence (**sequencer** functionality).

Beneath the channel name, information about channel-specific settings for the measurement is displayed in the **channel bar**. Channel information varies depending on the active application.

The channel bar above the diagram also contains information about instrument settings.

**Table 4-1: Contents of the channel bar (receiver application)**

Label	Information
"Meas BW"	Type and bandwidth of the currently selected resolution filter. The filter type label either reads "6 dB" or "MIL". For 3 dB filters, the label is not displayed.
"Att(enuation)"	Currently defined RF attenuation.
"Input"	Currently used RF input (1 or 2), including the input coupling (AC or DC).
"Meas Time"	Currently defined measurement time. For a scan count > 1, the measurement time is the sum of all single measurements.
"Preamp(lifier)"	Currently selected preamplifier state.
"PS"	Current state of the preselector.
"Step"	Currently selected scan type and frequency step mode. <ul style="list-style-type: none"> <li>• "LIN": Stepped scan with linear frequency steps. The frequency step size is a fix value in Hz.</li> <li>• "LOG": Stepped scan with logarithmic frequency steps. The frequency step size is a percentage of the current frequency.</li> <li>• "TD Scan": Time domain scan.</li> <li>• "Fixed Freq": Fixed frequency scan.</li> </ul>
"Notch"	Current state of the notch filter.
"Out"	Currently selected output type. If phones output is on, a corresponding icon is displayed.
"LISN"	Currently selected LISN and LISN phase. For R&S ENV216, it also shows the state of the highpass filter. Only displayed when a LISN is included in the measurement.
"SGL"	Indicates the progress of single measurements. The first number is the current measurement. The second number is the total number of measurements. Only displayed for single measurements and if the scan count is greater than 1.

Label	Information
"Frequency"	Current receiver frequency.
"75 Ω"	75 Ω input impedance has been selected.
"TRG"	Currently selected trigger source.
"TDF"	Currently selected transducers, including the input they have been assigned to.
Ext. Gen	An external generator is being controlled by the R&S ESW (requires optional hardware).

### Icons for individual settings

In the **receiver application**, a bullet next to the setting indicates that automatic settings are used, not user-defined settings.

In **other applications**, a bullet next to the setting indicates that user-defined settings are used, not automatic settings. A green bullet indicates that this setting is valid and the measurement is correct. A red bullet indicates an invalid setting that does not provide useful results.

## 4.1.2 Window Title Bar

Each channel in the R&S ESW display can contain several windows. Each window can display either a graph or a table as a result of the channel measurement. Which type of result evaluation is displayed in which window is defined in the display configuration (see [Chapter 4.5, "Displaying Results"](#), on page 68). The window's title bar indicates which type of evaluation is displayed.

### Trace information in window title bar

Information on the displayed traces is indicated in the window title bar.

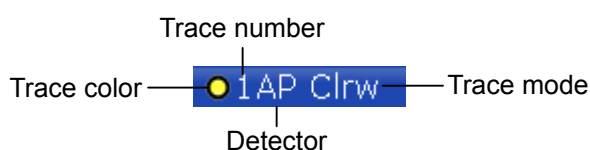

Trace color	Color of trace display in diagram
Trace no.	Number of the trace (1 to 6)



<b>Detector</b>	Abbreviation of the detector assigned to the trace: <ul style="list-style-type: none"> <li>• AP Autopoint detector</li> <li>• Av Average detector</li> <li>• CA CISPR AV detector</li> <li>• Mi Min Peak / Negative Peak detector</li> <li>• Pk Max Peak / Positive Peak detector</li> <li>• QP Quasipeak detector</li> <li>• RA RMS Average detector</li> <li>• Rm RMS detector</li> <li>• Sa Sample detector</li> </ul>
<b>Trace Mode</b>	Abbreviation of the trace mode: <ul style="list-style-type: none"> <li>• Clrw Clear Write: Shows the currently measured values.</li> <li>• Max Max Hold: Shows the maximum values that have been measured.</li> <li>• Min Min Hold: Shows the minimum values that have been measured.</li> <li>• Average Average: Shows the averaged values that have been measured.</li> <li>• View View: Shows a trace which remains the same when you perform another measurement.</li> <li>• Transducer Transducer: Shows the correction values of active transducer factors.</li> </ul>
<b>Norm/NCor</b>	Correction data is not used.

### 4.1.3 Marker Information

Marker information is provided either in the diagram grid or in a separate marker table, depending on the configuration.

#### Marker information in diagram grid

Within the diagram grid, the x-axis and y-axis positions of the last 2 markers or delta markers that were set are displayed, if available, as well as their index. The value in the square brackets after the index indicates the trace to which the marker is assigned. (Example: M2[1] defines marker 2 on trace 1.) For more than 2 markers, a separate marker table is displayed beneath the diagram by default.

#### Marker information in marker table

In addition to the marker information displayed within the diagram grid, a separate marker table can be displayed beneath the diagram. This table provides the following information for all active markers:

Label	Information
"Wnd"	Window type the marker is positioned in.
"Type"	Marker type: N (normal), D (delta), T (temporary, internal)
"Ref"	Reference (for delta markers)
"Trc"	Trace to which the marker is assigned
"X-value"	x-value of the marker
"Y-value"	y-value of the marker

#### 4.1.4 Frequency and Span Information in Diagram Footer

The information in the diagram footer (beneath the diagram) depends on the current application.

The contents depend on the application and the result display.

Label	Information
CF	Center frequency
Span	Frequency span (frequency domain display)
ms/	Time per division (time domain display)
Pts	Number of measurement points or (rounded) number of currently displayed points in zoom mode
Start	Start frequency of the scan
Stop	Stop frequency of the scan

#### 4.1.5 Instrument and Status Information



Global instrument settings and functions (such as LXI configuration mode), the instrument status and any irregularities are indicated in the status bar beneath the diagram.



In the MultiView tab, the status bar always displays the information for the currently selected measurement.

The following information is displayed:

### Instrument status

	The R&S ESW is configured for operation with an external reference. Selecting the "Ext Ref" icon opens a dialog box to configure the external reference.
	The status of an LXI connection (green label = connection established, red label = connection not established) Selecting the "LXI" icon opens a dialog box to configure the LXI connection.

### Progress

The status of the current operation is displayed in the status bar.



In the MultiView tab, the progress bar indicates the status of the currently selected measurement, not the measurement currently being performed by a sequencer, for example.

### Date and time

The date and time settings of the instrument are displayed in the status bar.



Selecting the date and time icon opens a dialog box to configure the date and time.

### Error messages and warnings

If errors or irregularities are detected, a keyword and an error message, if available, are displayed in the status bar.

### Knob configuration

Interfaces to configure the fast access knobs in the user interface and indicator of the currently selected knob function.

## 4.1.6 Error Information

If errors or irregularities are detected, a keyword and an error message, if available, are displayed in the status bar.



Depending on the type of message, the status message is indicated in varying colors.

**Table 4-2: Status bar information - color coding**

Color	Type	Description
Red	Error	An error occurred at the start or during a measurement, e.g. due to missing data or wrong settings, so that the measurement cannot be started or completed correctly.
Orange	Warning	An irregular situation occurred during measurement, e.g. the settings no longer match the displayed results, or the connection to an external device was interrupted temporarily.
Gray	Information	Information on the status of individual processing steps.
No color	No errors	No message displayed - normal operation.
Green	Measurement successful	Some applications visualize that the measurement was successful by showing a message.



If any error information is available for a channel, an exclamation mark is displayed next to the channel name (■). This is particularly useful when the MultiView tab is displayed, as the status bar in the MultiView tab always displays the information for the currently selected measurement only.

Furthermore, a status bit is set in the `STATUS:QUESTIONABLE:EXTENDED:INFO` register for the application concerned. Messages of a specific type can be queried using the `SYSTEM:ERROR:EXTENDED?` command. For more information, see the R&S ESW User Manual.

When you select the error message bar or status message bar, the R&S ESW shows a list of all current errors or status messages. In the error message bar, you can select one of the error messages to open a dialog box that can help you to remedy the error. Refer to the table below for information about which error message opens which dialog box.

**Table 4-3: List of keywords**

<b>AC COUP</b>	This label is displayed when a measurement is configured to be AC coupled, but information in the DC range is detected. This situation can yield inaccurate measurement results. You can avoid this error message by changing the input coupling type. Selecting the "AC Coup" error message opens a dialog box to configure the RF input.
<b>IF OVLD</b>	Overload of the IF signal path in the A/D converter or in the digital IF. <ul style="list-style-type: none"> <li>Increase the reference level.</li> </ul> Selecting the "IF OVLD" error message opens a dialog box to configure the amplitude.
<b>INPUT OVLD</b>	The signal level at the RF input connector exceeds the maximum. The RF input is disconnected from the input mixer to protect the device. To re-enable measurement, decrease the level at the RF input connector and reconnect the RF input to the mixer input. Selecting the "Input OVLD" error message opens a dialog box to configure the amplitude.
<b>LOUNL</b>	Error in the instrument's frequency processing hardware was detected.

<b>NO REF</b>	Instrument was set to an external reference but no signal was detected on the reference input. Selecting the "No Ref" error message opens a dialog box to configure the external reference.
<b>OVEN</b>	The optional OCXO reference frequency has not yet reached its operating temperature. The message usually disappears a few minutes after power has been switched on.
<b>RF OVLD</b>	Overload of the input mixer or of the analog IF path. <ul style="list-style-type: none"> <li>• Increase the RF attenuation (for RF input).</li> <li>• Reduce the input level (for digital input)</li> </ul> Selecting the "RF OVLD" error message opens a dialog box to configure the amplitude.
<b>UNCAL</b>	One of the following conditions applies: <ul style="list-style-type: none"> <li>• Correction data has been switched off.</li> <li>• No correction values are available, for example after a firmware update.</li> <li>• Record the correction data by performing a self alignment</li> </ul> Selecting the "Uncal" error message opens the "Self Alignment dialog box."
<b>WRONG_FW</b>	The firmware version is out-of-date and does not support the currently installed hardware. Until the firmware version is updated, this error message is displayed and self-alignment fails. Selecting the "Wrong_FW" error message opens a dialog box to manage firmware and options.

## 4.2 Accessing Functions

All tasks necessary to operate the instrument can be performed using the user interface. Apart from instrument specific keys, all other keys that correspond to an external keyboard (for example arrow keys, [Enter] key) operate conform to Microsoft.

For most tasks, there are at least 2 alternative methods to perform them:

- Using the touchscreen
- Using other elements provided by the front panel, for example the keypad, rotary knob, or arrow and position keys.

The measurement and instrument functions and settings can be accessed by selecting one of the following elements:

- System and function keys on the front panel of the instrument
- Softkeys on the touchscreen
- Context menus for specific elements on the touchscreen
- Icons on the tool bar in the touchscreen
- Displayed setting on the touchscreen

• <a href="#">Toolbar</a> .....	63
• <a href="#">Softkeys</a> .....	64
• <a href="#">Context Menus</a> .....	65
• <a href="#">On-screen Keyboard</a> .....	65









## 4.2.1 Toolbar

The icons in the toolbar provide access to general functions.



You can hide the toolbar display, for example when using remote control, in order to enlarge the display area for the measurement results ("Setup > Display > Displayed Items"). See the R&S ESW User Manual for details.

	Windows: opens the Windows "Start" menu and task bar.
	Open: opens a file from the instrument or an external device ("Save/Recall" menu).
	Store: stores data on the instrument or an external device ("Save/Recall" menu).
	Print: defines print settings ("Print" menu).
	Report Generator: opens the softkey menu to configure a report.
	Undo: reverts last operation
	Redo: repeats previously reverted operation
	Select: the cursor can be used to select (and move) elements in the display (markers, lines etc.).
	Zoom mode: displays a dotted rectangle in the diagram that can be expanded to define the zoom area.
	Multiple zoom mode: multiple zoom areas can be defined for the same diagram.
	Zoom off: displays the diagram in its original size.
	SmartGrid: activates "SmartGrid" mode to configure the screen layout.

	Sequencer: opens the "Sequencer" menu to perform consecutive measurements.
	Help (+ Select): allows you to select an element for which context-specific help is displayed.
	Help: displays context-sensitive help topic for currently selected element.
	Create report: creates a new measurement report and deletes previous report data.
	Create report: creates a new measurement report without deleting previous report data.
	RF input off: Signal applied to the RF input is not measured (instead the signal path of the calibration signal is used). Note that this icon is only visible if you deliberately turn it on. ([SETUP] > "Display" > "Displayed Items" > "Input Terminator")
	Frequency lock: Frequency does not change when you turn the rotary knob. Only applies to the frequency. You can still change other parameters with the rotary knob.
	Print immediately: prints the current display (screenshot) as configured.
In "SmartGrid" mode only:	
	Close: Exit "SmartGrid" mode.

## 4.2.2 Softkeys

Softkeys are virtual keys provided by the software. Thus, more functions can be provided than those that can be accessed directly via the function keys on the instrument. Softkeys are dynamic: depending on the selected function key, a different list of softkeys is displayed on the right side of the screen.

A list of softkeys for a certain function key is also called a menu. Softkeys can either perform a specific function or open a dialog box.

### Recognizing the softkey status by color

Color	Meaning
orange	associated dialog box is open
blue	associated function is active; for toggle keys: currently active state
gray	instrument function is temporarily not available due to a specific setting or missing option



You can hide the softkey display, e.g. when using remote control, in order to enlarge the display area for the measurement results ("Setup > Display > Displayed Items"). See the User Manual for details.

### 4.2.3 Context Menus

Several items in the diagram area have context-sensitive menus (for example markers, traces or the channel bar). If you right-click on one of these items (or tap it for about 1 second), a menu is displayed which contains the same functions as the corresponding softkey. This is useful, for example, when the softkey display is hidden.

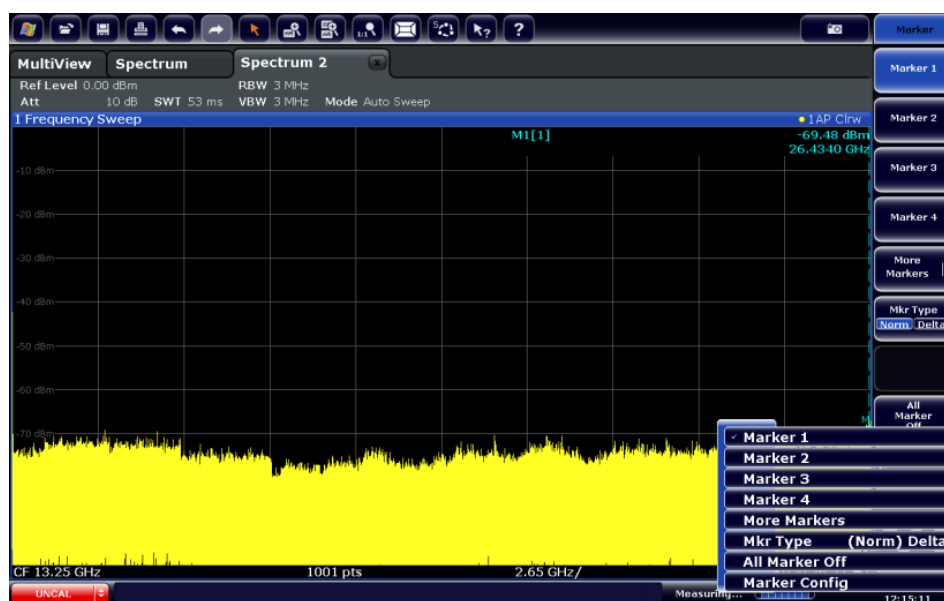

### 4.2.4 On-screen Keyboard

The on-screen keyboard is an additional means of interacting with the instrument without having to connect an external keyboard.

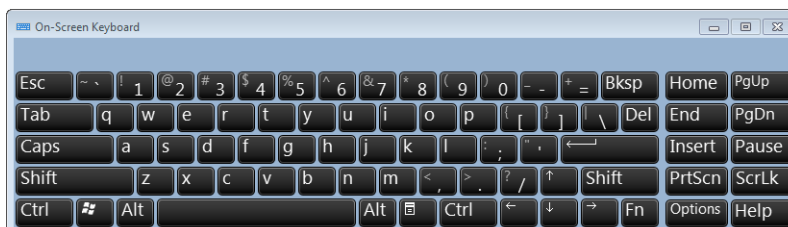

The on-screen keyboard display can be switched on and off as desired using the "On-Screen Keyboard" function key beneath the screen.



When you press this key, the display switches between the following options:



- Keyboard displayed at the top of the screen
- Keyboard displayed at the bottom of the screen
- No keyboard displayed



You can use the TAB key on the on-screen keyboard to move the focus from one field to another in dialog boxes.

## 4.3 Changing the Focus

Any selected function is always performed on the currently focused element in the display, e.g. a dialog field, diagram, or table row. Which element is focused is indicated by a blue frame (diagram, window, table) or is otherwise highlighted (softkey, marker etc.). Moving the focus is most easily done by tapping on the element on the touchscreen. Alternatively, use the "Tab" key on the on-screen keyboard or the rotary knob to move the focus from one element to the next on the display.



To move the focus between any displayed diagrams or tables in a window, press the "Change focus" key on the front panel. The focus moves from the diagram to the first table to the next table etc. and then back to the diagram, within the same window.

In fullscreen mode, where a single window is displayed in full size on the screen, this key switches the focus (and the display) from one active window to the next.

## 4.4 Entering Data

Data can be entered in dialog boxes using one of the following methods:

- Using the touchscreen, via the on-screen keyboard
- Using other elements provided by the front panel, e.g. the keypad, rotary knob, or navigation keys  
The rotary knob acts like the [ENTER] key when it is pressed.
- Using a connected external keyboard



### Transparent dialog boxes

You can change the transparency of the dialog boxes to see the results in the windows behind the dialog box. Thus, you can see the effects that the changes you make to the settings have on the results immediately.

To change the transparency, use the slider at the top of the dialog box.



(The title bar of the dialog box is always slightly transparent and is not affected by the slider.)



### Particularities in Windows dialog boxes

In some cases, e.g. if you want to install a printer, original Windows dialog boxes are used. In these dialog boxes, the rotary knob and function keys do not work. Use the touchscreen instead.

## 4.4.1 Entering Numeric Parameters

If a field requires numeric input, the keypad provides only numbers.

1. Enter the parameter value using the keypad, or change the currently used parameter value by using the rotary knob (small steps) or the [UP] or [DOWN] keys (large steps).
2. After entering the numeric value via keypad, press the corresponding unit key. The unit is added to the entry.
3. If the parameter does not require a unit, confirm the entered value by pressing the [ENTER] key or any of the unit keys. The editing line is highlighted to confirm the entry.

## 4.4.2 Entering Alphanumeric Parameters

If a field requires alphanumeric input, you can use the on-screen keyboard to enter numbers and (special) characters (see [Chapter 4.2.4, "On-screen Keyboard"](#), on page 65).

Alternatively, you can use the keypad. Every alphanumeric key represents several characters and one number. The decimal point key (.) represents special characters, and the sign key (-) toggles between capital and small letters. For the assignment, refer to [Table 4-4](#).

### To enter numbers and (special) characters via the keypad

1. Press the key once to enter the first possible value.
2. All characters available via this key are displayed.
3. To choose another value provided by this key, press the key again, until your desired value is displayed.
4. With every key stroke, the next possible value of this key is displayed. If all possible values have been displayed, the series starts with the first value again. For information on the series, refer to [Table 4-4](#).
5. To change from capital to small letters and vice versa, press the sign key (-).
6. When you have chosen the desired value, wait for 2 seconds (to use the same key again), or start the next entry by pressing another key.

**To enter a blank**

- ▶ Press the "Space" bar, or press the "0" key and wait 2 seconds.

**To correct an entry**

1. Using the arrow keys, move the cursor to the right of the entry you want to delete.
2. Press the [BACKSPACE] key.  
The entry to the left of the cursor is deleted.
3. Enter your correction.

**To complete the entry**

- ▶ Press the [ENTER] key or the rotary knob.

**To abort the entry**

- ▶ Press the [ESC] key.  
The dialog box is closed without changing the settings.

**Table 4-4: Keys for alphanumeric parameters**

Key name (upper inscription)	Series of (special) characters and number provided
7	7 μ Ω ° € ¥ \$ ¢
8	A B C 8 Ä Æ Å Ç
9	D E F 9 É
4	G H I 4
5	J K L 5
6	M N O 6 Ñ Ö
1	P Q R S 1
2	T U V 2 Ü
3	W X Y Z 3
0	<blank> 0 – @ + / \ < > = % &
.	. * : _ , ; " ' ? ( ) #
–	<toggles between capital and small letters>

## 4.5 Displaying Results

The R&S ESW provides several instrument applications for different analysis tasks and different types of signals, for example the Receiver application, the Spectrum application or the I/Q Analyzer. For each application, a new measurement channel is created and displayed in a separate tab on the screen.

The results of a measurement channel can be evaluated in many different ways, both graphically and numerically. For each evaluation method the results are displayed in a separate window in the tab.

The R&S ESW allows you to configure the display to suit your specific requirements and optimize analysis.

#### 4.5.1 Activating and Deactivating Channels

When you activate an application, a new measurement channel is created which determines the measurement settings for that application. The same application can be activated with different measurement settings by creating several channels for the same application. Whenever you switch channels, the corresponding measurement settings are restored. Each channel is displayed in a separate tab on the screen.

An additional tab ("MultiView") provides an overview of all currently active channels at once.

Only one measurement can be performed at any time, namely the one in the currently active channel. However, in order to perform the configured measurements consecutively, a Sequencer function is provided.

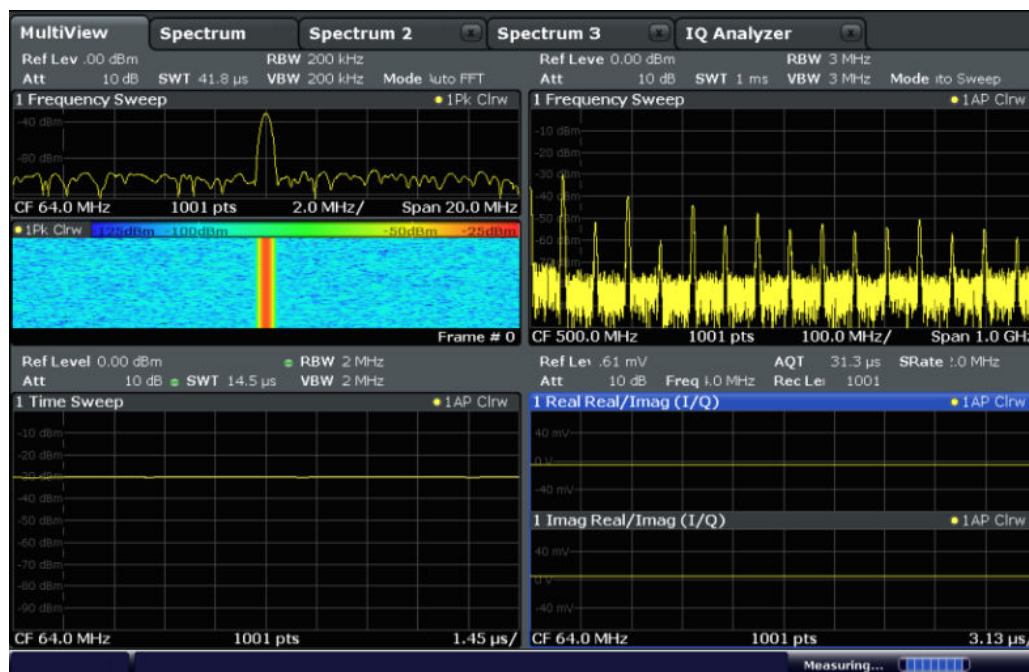

##### To start a new channel

1. Select the [Mode] key.
2. In the "Mode" dialog box, select the required application on the "New Channel" tab. A new tab is displayed for the new channel.

**Remote command:**

[INSTRUMENT:CREate\[:NEW\]](#) on page 423/ [INSTRUMENT:CREate:DUPLicate](#) on page 423

**To change the application in an active channel**

1. Select the tab of the channel you want to change.
2. Select the [Mode] key.
3. In the "Mode" dialog box, select the new application to be displayed on the "Replace Current Channel" tab.  
The selected application is displayed in the current channel.

**Remote command:**

[INSTRUMENT:CREate:REPLace](#) on page 423

**To close a measurement channel**

Select the "Close" icon on the tab of the measurement channel.

The tab is closed, any running measurements are aborted, and all results for that channel are deleted.

**Remote command:**

[INSTRUMENT:DELeTe](#) on page 424

## 4.5.2 Laying out the Result Display with the SmartGrid

Measurement results can be evaluated in many different ways, for example graphically, as summary tables, statistical evaluations etc. Each type of evaluation is displayed in a separate window in the channel tab. Up to 16 individual windows can be displayed per channel (i.e. per tab). To arrange the diagrams and tables on the screen, the Rohde & Schwarz SmartGrid function helps you find the target position simply and quickly.

Principally, the layout of the windows on the screen is based on an underlying grid, the SmartGrid. However, the SmartGrid is dynamic and flexible, allowing for many different layout possibilities. The SmartGrid functionality provides the following basic features:

- Windows can be arranged in columns or in rows, or in a combination of both.
- Windows can be arranged in up to four rows and four columns.
- Windows are moved simply by dragging them to a new position on the screen, possibly changing the layout of the other windows, as well.
- All evaluation methods available for the currently selected measurement are displayed as icons in the evaluation bar. If the evaluation bar contains more icons than can be displayed at once on the screen, it can be scrolled vertically. The same evaluation method can be displayed in multiple windows simultaneously.

- New windows are added by dragging an evaluation icon from the evaluation bar to the screen. The position of each new window depends on where you drop the evaluation icon in relation to the existing windows.
- All display configuration actions are only possible in SmartGrid mode. When SmartGrid mode is activated, the evaluation bar replaces the current softkey menu display. When the SmartGrid mode is deactivated again, the previous softkey menu display is restored.
- [Background Information: The SmartGrid Principle](#).....71
- [How to Activate SmartGrid Mode](#).....72
- [How to Add a New Result Window](#).....73
- [How to Close a Result Window](#).....73
- [How to Arrange the Result Windows](#).....74

#### 4.5.2.1 Background Information: The SmartGrid Principle

##### SmartGrid display

During any positioning action, the underlying SmartGrid is displayed. Different colors and frames indicate the possible new positions. The position in the SmartGrid where you drop the window determines its position on the screen.

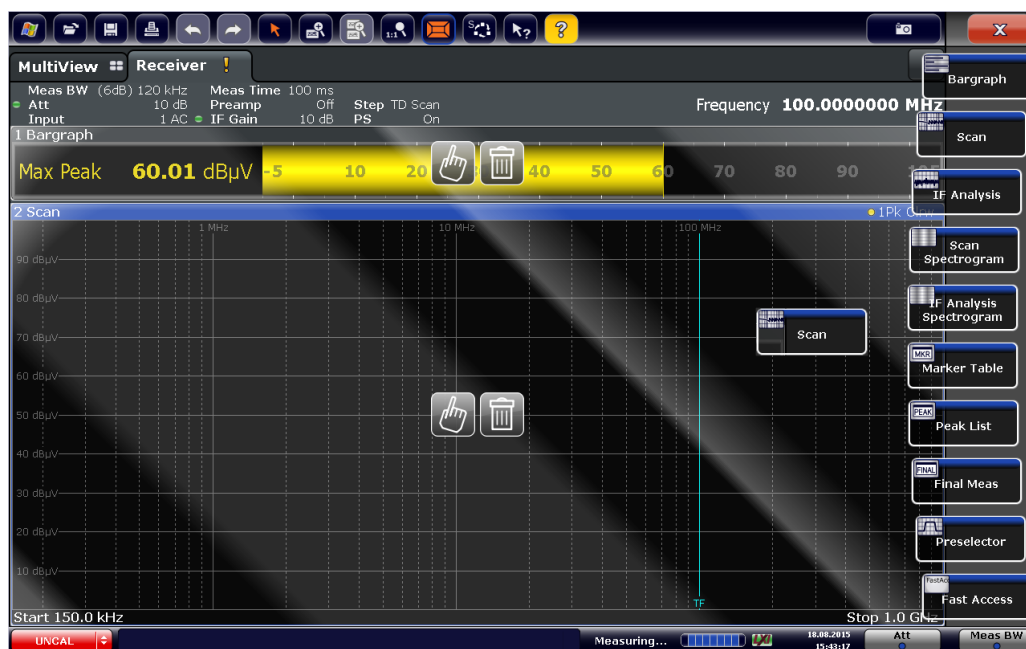
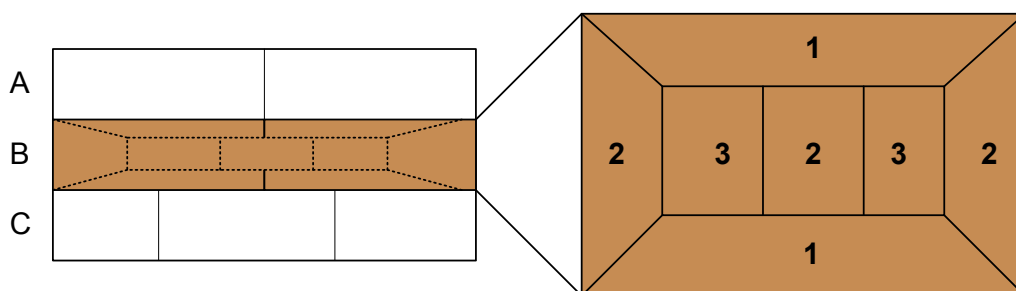

Figure 4-1: Moving a window in SmartGrid mode

The brown area indicates the possible "drop area" for the window, i.e. the area in which the window can be placed. A blue area indicates the (approximate) layout of the window as it would be if the icon were dropped at the current position. The frames indicate the possible destinations of the new window with respect to the existing windows: above/below, right/left or replacement (as illustrated in [Figure 4-2](#)). If an existing window would be replaced, the drop area is highlighted in a darker color shade.

### Positioning the window

The screen can be divided into up to four rows. Each row can be split into up to four columns, where each row can have a different number of columns. However, rows always span the entire width of the screen and may not be interrupted by a column. A single row is available as the drop area for the window in the SmartGrid. The row can be split into columns, or a new row can be inserted above or below the existing row (if the maximum of 4 has not yet been reached).



**Figure 4-2: SmartGrid window positions**

- 1 = Insert row above or below the existing row
- 2 = Create a new column in the existing row
- 3 = Replace a window in the existing row

### SmartGrid functions

Once the evaluation icon has been dropped, icons in each window provide delete and move functions.



The "Move" icon allows you to move the position of the window, possibly changing the size and position of the other displayed windows.



The "Delete" icon allows you to close the window, enlarging the display of the remaining windows.

#### 4.5.2.2 How to Activate SmartGrid Mode

All display configuration actions are only possible in SmartGrid mode. In SmartGrid mode the evaluation bar replaces the current softkey menu display. When the SmartGrid mode is deactivated again, the previous softkey menu display is restored.

- ▶ To activate SmartGrid mode, do one of the following:



- Select the "SmartGrid" icon from the toolbar.
- Select the "Display Config" button in the configuration "Overview" .

- Select the "Display Config" softkey from the [MEAS CONFIG] menu.

The SmartGrid functions and the evaluation bar are displayed.



To close the SmartGrid mode and restore the previous softkey menu select the "Close" icon in the right-hand corner of the toolbar, or press any key.

#### 4.5.2.3 How to Add a New Result Window

Each type of evaluation is displayed in a separate window. Up to 16 individual windows can be displayed per channel (i.e. per tab).

1. Activate SmartGrid mode.

All evaluation methods available for the currently selected measurement are displayed as icons in the evaluation bar.

2. Select the icon for the required evaluation method from the evaluation bar.  
If the evaluation bar contains more icons than can be displayed at once on the screen, it can be scrolled vertically. Touch the evaluation bar between the icons and move it up or down until the required icon appears.
3. Drag the required icon from the evaluation bar to the SmartGrid, which is displayed in the diagram area, and drop it at the required position. (See [Chapter 4.5.2.5, "How to Arrange the Result Windows"](#), on page 74 for more information on positioning the window).

**Remote command:**

`LAYout:ADD[:WINDow]?` on page 505 / `LAYout:WINDow<n>:ADD?` on page 509

#### 4.5.2.4 How to Close a Result Window

- ▶ To close a window, activate SmartGrid mode and select the "Delete" icon for the window.



**Remote command:**

`LAYout:REMove[:WINDow]` on page 507 / `LAYout:WINDow<n>:REMove` on page 510



#### 4.5.2.5 How to Arrange the Result Windows

1. Select an icon from the evaluation bar or the "Move" icon for an existing evaluation window.



2. Drag the evaluation over the SmartGrid.  
A blue area shows where the window will be placed.
3. Move the window until a suitable area is indicated in blue.
4. Drop the window in the target area.  
The windows are rearranged to the selected layout, and "Delete" and "Move" icons are displayed in each window.
5. To close a window, select the corresponding "Delete" icon.



**Remote command:**

[LAYout:REPLace\[:WINDow\]](#) on page 507 / [LAYout:WINDow<n>:REPLace](#) on page 510

#### 4.5.3 Changing the Size of Windows

Each channel tab may contain several windows to evaluate the measurement results using different methods. A "splitter" allows you to change the size of neighboring windows.

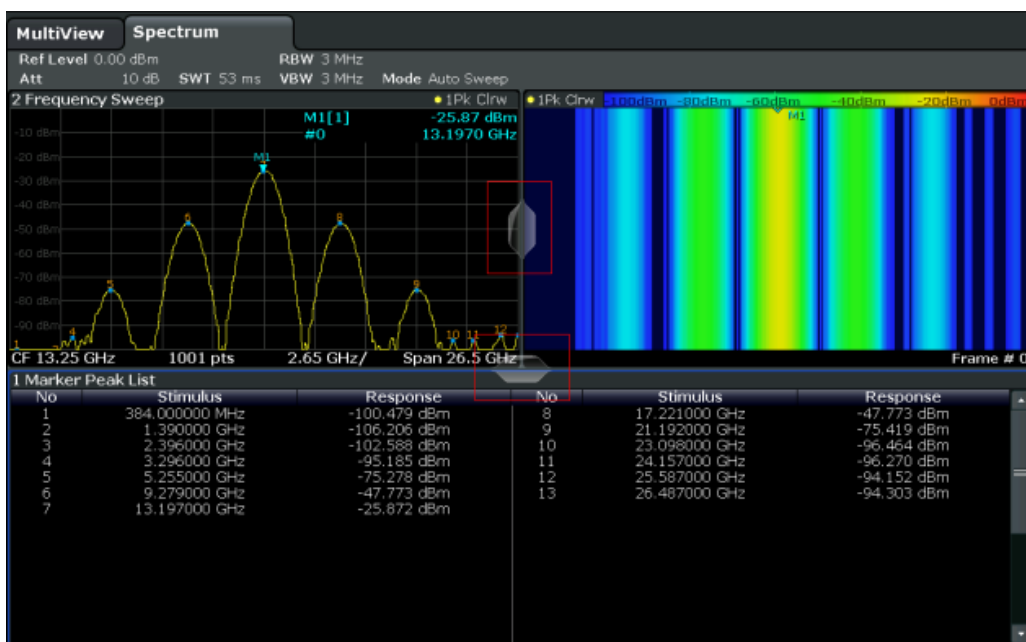

The splitters are not available in SmartGrid mode.

- ▶ To change the size of two neighboring windows, drag the splitter between the windows in either direction.

#### 4.5.4 Switching Between a Split and Maximized Window Display

To get an overview of the results, displaying several windows at the same time may be helpful. However, the individual windows may become rather small. In this case it is useful to maximize an individual window to the entire screen temporarily in order to analyze the results in more detail.



To switch between a split and a maximized display without having to close and re-open windows, press the [SPLIT/MAXIMIZE] key on the front panel. In maximized display, the currently focused window is maximized. In split display, all active windows are displayed.

Alternatively, double-tap the title bar of a window to maximize it.

#### 4.5.5 Changing the Display

The display can be optimized for your individual needs. The following display functions are available and are described in detail in [Chapter 11.2, "Display Settings"](#), on page 294 and [Chapter 9.1, "Result Display Configuration"](#), on page 182.

- Displaying a simulation of the entire front panel of the instrument on the screen ("Front Panel")
- Displaying the main function hardkeys in a separate window on the screen ("Mini Front Panel")
- Hiding or showing various screen elements
- Selecting a display theme and colors
- Changing the display update rate
- Activating or deactivating the touch-sensitivity of the screen
- Zooming into the diagram

## 4.6 Getting Help

If any questions or problems concerning the R&S ESW arise, an extensive online help system is provided on the instrument and can be consulted at any time. The help system is context-sensitive and provides information specifically for the current operation or setting to be performed. In addition, general topics provide an overview on complete tasks or function groups as well as background information.

### 4.6.1 Calling Up Help

The online help can be opened at any time by selecting one of the "Help" icons on the toolbar or by pressing the F1 key on an external or the on-screen keyboard.

#### Calling context-sensitive help

- ▶ To display the "Help" dialog box for the currently focused screen element, e.g. a softkey or a setting in an opened dialog box, select the "Help" icon on the toolbar.



The "Help" dialog box "View" tab is displayed. A topic containing information about the focused screen element is displayed.

If no context-specific help topic is available, a more general topic or the "Content" tab is displayed.



For standard Windows dialog boxes (e.g. File Properties, Print dialog etc.), no context-sensitive help is available.

- ▶ To display a help topic for a screen element not currently focused:
  - a) Select the "Help pointer" icon on the toolbar.



The pointer changes its shape to a "?" and an arrow.

b) Select the screen element to change the focus.

A topic containing information about the selected (now focused) screen element is displayed.

## 4.6.2 Using the Help Window

The Help window contains several tabs:

- "View" - shows the selected help topic
- "Contents" - contains a table of help contents
- "Index" - contains index entries to search for help topics
- "Search" - provides text search



The Help toolbar provides some buttons:

- To browse the topics in the order of the table of contents: Up arrow = previous topic, Down arrow = next topic
- To browse the topics visited before: Left arrow = back, Right arrow = forward
- To increase or decrease the font



To navigate the Help, use the touchscreen. Alternatively, you can also use the navigation keys on the front panel.

### To search for a topic in the index

The index is sorted alphabetically. You can browse the list, or search for entries in the list.

1. Switch to the "Index" tab.
2. Select the "Keyboard" icon besides the entry field.
3. Enter the first characters of the keyword you are interested in.  
The entries containing these characters are displayed.
4. Double-tap the suitable index entry.  
The "View" tab with the corresponding help topic is displayed.

### To search topics for a text string

1. Switch to the "Search" tab.
2. Select the "Keyboard" icon besides the entry field.
3. Enter the string you want to find.

If you enter several strings with blanks between, topics containing all words are found (same as AND operator).

For advanced search, consider the following:

- To find a defined string of several words, enclose it in quotation marks. For example, a search for *"trigger qualification"* finds all topics with exactly *"trigger qualification"*. A search for *trigger qualification* finds all topics that contain the words *trigger* and *qualification*.
- Use "Match whole word" and "Match case" to refine the search.
- Use operators AND, OR, and NOT.

#### To close the Help window

- ▶ Select the "Close" icon in the upper right corner of the help window.  
Or: Press the [ESC] key.

## 4.7 Remote Control

In addition to working with the R&S ESW interactively, located directly at the instrument, it is also possible to operate and control it from a remote PC. Various methods for remote control are supported:

- Connecting the instrument to a (LAN) network (see [Chapter 2.5, "Setting Up a Network \(LAN\) Connection"](#), on page 32)
- Using the LXI browser interface in a LAN network
- Using the Windows Remote Desktop application in a LAN network
- Connecting a PC via the GPIB interface

How to configure the remote control interfaces is described in the User Manual.



The R&S ESW is delivered with *IECWIN* installed, the auxiliary remote control tool provided free of charge by R&S.

For details on the IECWIN tool, see the "Network and Remote Control" chapter of the R&S ESW User Manual.

---

### 4.7.1 Using the LXI Browser Interface in a LAN

LAN eXtensions for Instrumentation (LXI) is an instrumentation platform for measuring instruments and test systems that is based on standard Ethernet technology. LXI is intended to be the LAN-based successor to GPIB, combining the advantages of Ethernet with the simplicity and familiarity of GPIB. The LXI browser interface allows for easy configuration of the LAN and remote control of the R&S ESW without additional installation requirements.



### Restrictions

For details see [Chapter 2.2.3, "Login"](#), on page 26.

Via the LXI browser interface to the R&S ESW you can control the instrument remotely from another PC. Manual instrument controls are available via the front panel simulation. File upload and download between the instrument and the remote PC is also available. Using this feature, several users can access *and operate* the R&S ESW simultaneously. This is useful for troubleshooting or training purposes. If necessary, this feature can be deactivated.

For details see "[LXI Web Browser Interface](#)" on page 348.

## 4.7.2 Remote Desktop Connection

Remote Desktop is a Windows application which can be used to access and control the instrument from a remote computer through a LAN connection. While the instrument is in operation, the instrument screen contents are displayed on the remote computer. Remote Desktop provides access to all of the applications, files, and network resources of the instrument. Thus, remote operation of the instrument is possible.

The Remote Desktop Client is part of the installed Windows operating system. For other versions of Windows, Microsoft offers the Remote Desktop Client as an add-on.

## 4.7.3 Connecting a PC via the GPIB Interface

You can connect a PC to the R&S ESW via the GPIB interface to send remote commands to control and operate the instrument. You can configure the GPIB address and the ID response string. The GPIB language is set as SCPI by default but can be changed to emulate other instruments.

A GPIB interface is integrated on the rear panel of the instrument.

## 5 Collecting Information for Technical Support

If problems occur, the instrument generates error messages which in most cases will be sufficient for you to detect the cause of an error and find a remedy.

In addition, our customer support centers are there to assist you in solving any problems that you may encounter with your R&S ESW. We will find solutions more quickly and efficiently if you provide us with the information listed below.

- **System Configuration:** The "System Configuration" dialog box (in the "Setup" menu) provides information on:
  - **Hardware Info:** hardware assemblies
  - **Versions and Options:** the status of all software and hardware options installed on your instrument
  - **System Messages:** messages on any errors that may have occurred

An .xml file with information on the system configuration ( "Device Footprint" ) can be created automatically (using the `DIAGnostic:SERvice:SINfo` command or as described in "To collect the support information" on page 80).

- **Error Log:** The `RSError.log` file (in the `C:\Program Files (x86)\Rohde-Schwarz\ESW\<version>\log` directory) contains a chronological record of errors.
- **Support file:** a \*.zip file with important support information can be created automatically (in the `C:\Program Files (x86)\Rohde-Schwarz\ESW\<version>\user` directory). The \*.zip file contains the system configuration information ( "Device Footprint" ), the current eeprom data and a screenshot of the screen display.

### To collect the support information

1. Press the [SETUP] key.
2. Select "Service" > "R&S Support" and then "Create R&S Support Information" .

The file is stored as

```
C:\Program Files (x86)\Rohde-Schwarz\ESW\<version>\user\  
<inst_model>_<serial-no>_<date_and_time>.zip
```

The file is stored as

```
C:\Program Files (x86)\Rohde-Schwarz\ESW\<version>\user\  
ESW_*.zip.
```

Collect the error information and attach it to an email in which you describe the problem. Send the email to the customer support address for your region as listed on the Internet (<http://www.customersupport.rohde-schwarz.com>).



### Packing and transporting the instrument

If the instrument needs to be transported or shipped, observe the notes described in Chapter 2.1.1, "Unpacking and Checking the Instrument", on page 20.

## 6 Applications

The R&S ESW provides several applications for different analysis tasks (for example the Receiver application or the I/Q Analyzer). When you activate an application, the R&S ESW creates a new measurement channel which in turn determines the measurement settings for that application. You can use the same application with different measurement settings by creating several channels for the same application. Each channel is represented by a separate tab on the screen.

Note that the number of channels may be limited by the available memory of the R&S ESW.

### Switching between applications

When you enter another application for the first time, a set of selected parameters is passed on from the current application to the other one, for example the measurement frequency or the attenuation. Thus, you can switch between applications quickly and easily.

You can also define a fix set of parameters that are synchronized between applications. For more information see [Chapter 11.7, "Synchronizing Measurement Channel Configuration"](#), on page 335.

- [R&S MultiView](#)..... 81
- [Available Applications](#)..... 82
- [Starting an Application](#)..... 84
- [Running a Sequence of Measurements](#).....85

### 6.1 R&S MultiView

Each application is displayed in a separate tab. An additional tab ("MultiView") provides an overview of all currently active channels at a glance. In the "MultiView" tab, each individual window contains its own channel bar with an additional button. Select this button to switch to the corresponding channel display quickly.



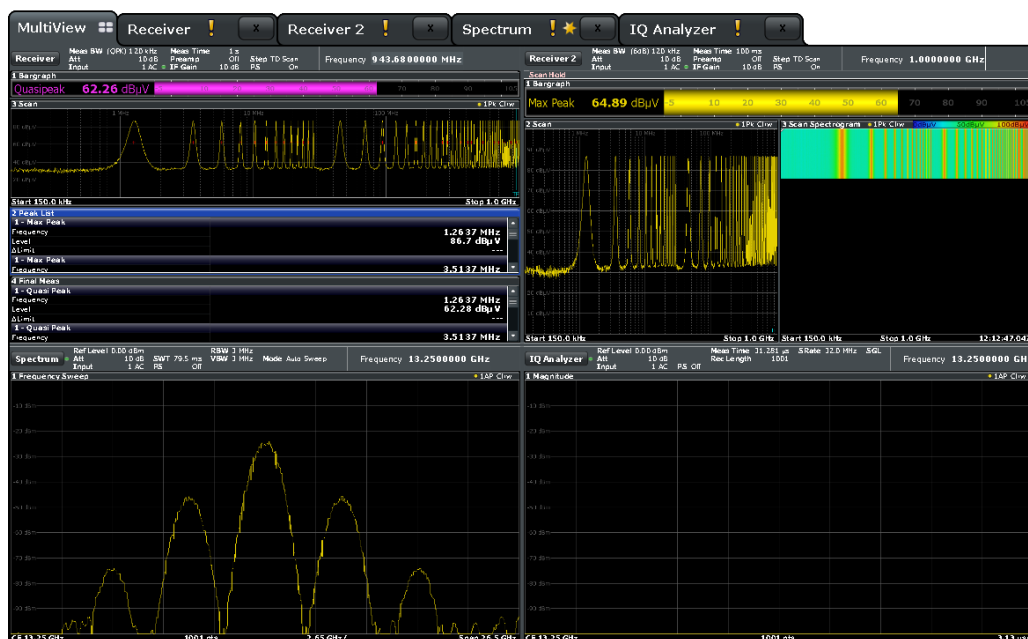

Remote command:  
[DISPlay:FORMat](#) on page 504

## 6.2 Available Applications

The R&S ESW provides several applications for specific measurement tasks.



### Spectrogram application

Spectrogram measurements are not a separate application, but rather a trace evaluation method, thus they are available as an evaluation method for the Display Configuration, not by creating a new channel. Spectrograms are configured and activated in the "Trace" settings. See [Chapter 9.3.1.3, "Working with Spectrograms"](#), on page 196 for details.

<a href="#">Receiver</a> .....	82
<a href="#">CISPR APD</a> .....	83
<a href="#">Spectrum</a> .....	83
<a href="#">I/Q Analyzer</a> .....	83
<a href="#">Analog Demodulation</a> .....	83
<a href="#">Real-Time Spectrum</a> .....	83

### Receiver

The Receiver application provides measurement functions to perform EMC measurements.

All functions of the Receiver application are described in this document.

Remote command:

INST:SEL REC, see [INSTrument\[:SElect\]](#) on page 425

### CISPR APD

The CISPR APD (Amplitude Probability Distribution) application provides measurement functions to determine the likelihood of emissions being above a certain level.

For details see [Chapter 7.4, "CISPR APD Measurements"](#), on page 131.

Remote command:

INST:SEL APD, see [INSTrument\[:SElect\]](#) on page 425

### Spectrum

In the Spectrum application the provided functions correspond to those of a conventional spectrum analyzer. The analyzer measures the frequency spectrum of the RF input signal over the selected frequency range with the selected resolution and sweep time, or, for a fixed frequency, displays the waveform of the video signal. This application is used in the initial configuration.

For details refer to the Spectrum Analyzer User Manual.

Remote command:

INST:SEL SAN, see [INSTrument\[:SElect\]](#) on page 425

### I/Q Analyzer

The I/Q Analyzer application provides measurement and display functions for I/Q data.

For details see the I/Q Analyzer User Manual.

Remote command:

INST:SEL IQ, see [INSTrument\[:SElect\]](#) on page 425

### Analog Demodulation

The Analog Demodulation application provides measurement functions for demodulating AM, FM, or PM signals.

For details see the Analog Demodulation User Manual.

Remote command:

INST:SEL ADEM, see [INSTrument\[:SElect\]](#) on page 425

### Real-Time Spectrum

The Real-Time Spectrum application requires an instrument equipped with the Real-Time Spectrum option. This application provides real-time measurement functions.

For details see the R&S ESW Real-Time User Manual.

Remote command:

INST:SEL RTIM, see [INSTrument\[:SElect\]](#) on page 425

## 6.3 Starting an Application

### Access

- ▶ [MODE] > "<application>"

The default application that is running when you start the R&S ESW is the Receiver application.

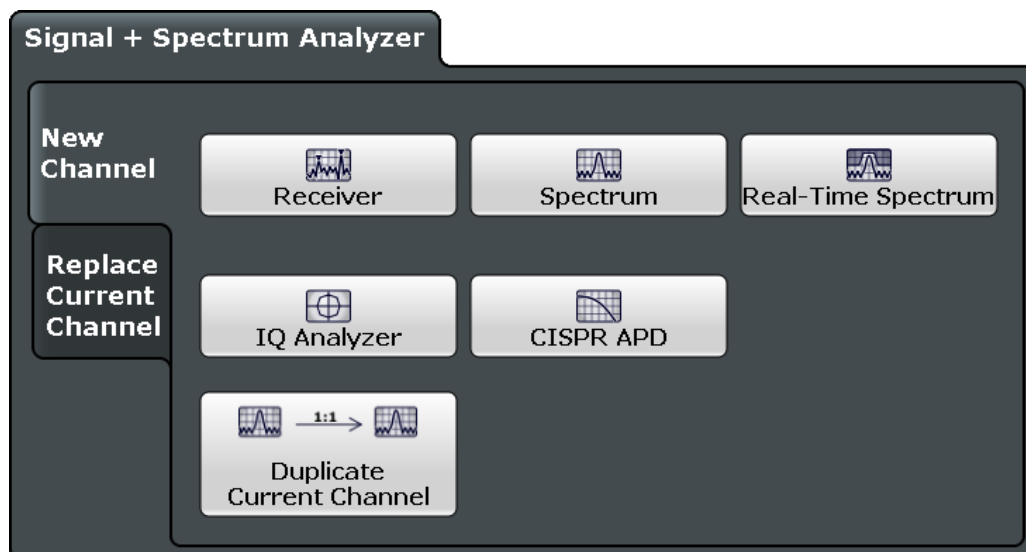

The remote commands required to perform these tasks are described in [Chapter 13.4, "Application Selection"](#), on page 422.



The measurement channels are labeled with their default name. If that name already exists, a sequential number is added.

You can define a different channel name by selecting (double-click) the corresponding label.



In remote control, the name of the measurement channel can also be changed. For details and an overview of default names see [Table 13-2](#).

### Switching between applications

When you enter a new application, a set of parameters is passed on from the current application to the new one, for example the measurement frequency or the attenuation.

You can also define a fix set of parameters that are synchronized between applications. For more information see [Chapter 11.7, "Synchronizing Measurement Channel Configuration"](#), on page 335.



To deactivate a channel, simply close the corresponding tab.

New Channel.....	85
Replace Current Channel.....	85
Duplicate Current Channel .....	85

### New Channel

The applications selected on this tab are started in a new measurement channel, i.e. a new tab in the display.

Remote command:

`INSTRument:CREate[:NEW]` on page 423

`INSTRument[:SElect]` on page 425

### Replace Current Channel

The applications selected on this tab are started in the currently displayed measurement channel, replacing the current application.

Remote command:

`INSTRument:CREate:REPLace` on page 423

### Duplicate Current Channel

The currently active channel can be duplicated, i.e. a new channel of the same type and with the identical measurement settings is started. The name of the new channel is the same as the copied channel, extended by a consecutive number (e.g. "Spectrum" - > "Spectrum 2").

Remote command:

`INSTRument:CREate:DUPLicate` on page 423

## 6.4 Running a Sequence of Measurements

Only one measurement can be performed at any time, namely the one in the currently active channel. However, in order to perform the configured measurements consecutively, a Sequencer function is provided.

• <a href="#">The Sequencer Concept</a> .....	85
• <a href="#">Sequencer Settings</a> .....	88
• <a href="#">How to Set Up the Sequencer</a> .....	88

### 6.4.1 The Sequencer Concept

The instrument can only activate one specific channel at any time. Thus, only one measurement can be performed at any time, namely the one in the currently active channel. However, in order to perform the configured measurements consecutively, a Sequencer function is provided, which changes the channel of the instrument as

required. If activated, the measurements configured in the currently defined "Channel" s are performed one after the other in the order of the tabs.

For each individual measurement, the sweep count is considered. Thus, each measurement may consist of several sweeps. The currently active measurement is indicated by a  symbol in the tab label.

The result displays of the individual channels are updated in the tabs as the measurements are performed. Sequential operation itself is independent of the currently *displayed* tab.

### Sequencer modes

Three different Sequencer modes are available:

- **Single Sequence**  
Similar to single sweep mode; each measurement is performed once, until all measurements in all defined "Channel" s have been performed.
- **Continuous Sequence**  
Similar to continuous sweep mode; the measurements in each defined "Channel" are performed one after the other, repeatedly, in the same order, until sequential operation is stopped. This is the default Sequencer mode.
- **Channel-defined Sequence**  
First, a single sequence is performed. Then, only "Channel" s in continuous sweep mode are repeated continuously.

**Example: Sequencer procedure**

Assume the following active channel definition:

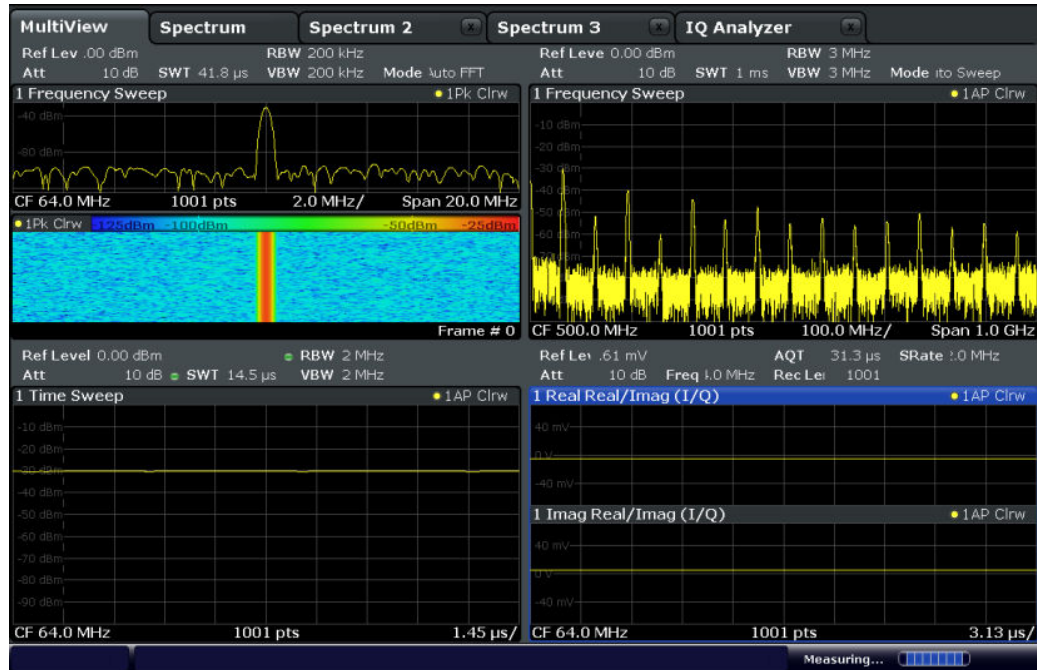

Tab name	Application	Sweep mode	Sweep count
Spectrum	Spectrum	Cont. Sweep	5
Spectrum 2	Spectrum	Single Sweep	6
Spectrum 3	Spectrum	Cont. Sweep	2
IQ Analyzer	IQ Analyzer	Single Sweep	7

For **Single Sequence**, the following sweeps will be performed:

5x Spectrum, 6x Spectrum 2, 2 x Spectrum 3, 7x IQ Analyzer

For **Continuous Sequence**, the following sweeps will be performed:

5x Spectrum, 6x Spectrum 2, 2 x Spectrum 3, 7x IQ Analyzer,

5x Spectrum, 6x Spectrum 2, 2 x Spectrum 3, 7x IQ Analyzer,

...

For **Channel-defined Sequence**, the following sweeps will be performed:

5x Spectrum, 6x Spectrum 2, 2 x Spectrum 3, 7x IQ Analyzer,

5x Spectrum, 2 x Spectrum 3,

5x Spectrum, 2 x Spectrum 3,

...

**RUN SINGLE/RUN CONT and Single Sweep/Sweep Continuous keys**

While the Sequencer is active, the [RUN SINGLE] and [RUN CONT] keys control the Sequencer, not individual sweeps. [RUN SINGLE] starts the Sequencer in single mode, while [RUN CONT] starts the Sequencer in continuous mode.

The "Single Sweep" and "Continuous Sweep" *softkeys* control the sweep mode for the currently selected channel only; the sweep mode only has an effect the next time the Sequencer activates that channel, and only for a channel-defined sequence. In this case, a channel in single sweep mode is swept only once by the Sequencer. A channel in continuous sweep mode is swept repeatedly.

### 6.4.2 Sequencer Settings



The "Sequencer" menu is available from the toolbar.

Functions of the Sequencer in the Receiver application described elsewhere:

- "Performing sequenced measurements" on page 91

Sequencer State .....	88
Sequencer Mode .....	88

#### Sequencer State

Activates or deactivates the Sequencer. If activated, sequential operation according to the selected Sequencer mode is started immediately.

Remote command:

`SYSTEM:SEQuencer` on page 432

`INITiate<n>:SEQuencer:IMMediate` on page 431

`INITiate<n>:SEQuencer:ABORt` on page 430

#### Sequencer Mode

Defines how often which measurements are performed. The currently selected mode softkey is highlighted blue. During an active Sequencer process, the selected mode softkey is highlighted orange.

"Single Sequence"

Each measurement is performed once, until all measurements in all active channels have been performed.

"Continuous Sequence"

The measurements in each active channel are performed one after the other, repeatedly, in the same order, until sequential operation is stopped.

This is the default Sequencer mode.

Remote command:

`INITiate<n>:SEQuencer:MODE` on page 431

### 6.4.3 How to Set Up the Sequencer

In order to perform the configured measurements consecutively, a Sequencer function is provided.

1. Configure a channel for each measurement configuration as required, including the sweep mode.

2. In the toolbar, select the "Sequencer" icon.



The "Sequencer" menu is displayed.

3. Toggle the "Sequencer" softkey to "On" .

A continuous sequence is started immediately.

4. To change the Sequencer mode and start a new sequence immediately, select the corresponding mode softkey, or press the [RUN SINGLE] or [RUN CONT] key.

The measurements configured in the currently active channels are performed one after the other in the order of the tabs until the Sequencer is stopped.

The result displays in the individual channels are updated as the measurements are performed.

#### **To stop the Sequencer**

- ▶ To stop the Sequencer temporarily, press the highlighted [RUN SINGLE] or [RUN CONT] key (not for a channel-defined sequence). To continue the Sequencer, press the key again.  
To stop the Sequencer permanently, select the "Sequencer" icon in the toolbar and toggle the "Sequencer" softkey to "Off" .



## 7 Measurements and Result Displays

The measurements and result displays available in the Receiver application allow you to analyze the frequency spectrum for possible interferers and the characteristics of those interferers.

- [Performing Measurements](#).....90
- [Bargraph Configuration](#).....92
- [Test Automation](#).....97
- [CISPR APD Measurements](#).....131

### 7.1 Performing Measurements

The R&S ESW provides several approaches to do measurements and acquire the signal data.

**Access:** [SWEEP]

Functions in the "Sweep" menu described elsewhere:

- ["Measurement Time"](#) on page 95
- ["Selecting the scan type"](#) on page 108
- ["Select Frame"](#) on page 208
- [Chapter 7.3.3.1, "Designing a Scan Table"](#), on page 109

<a href="#">Performing continuous measurements</a> .....	90
<a href="#">Performing single measurements</a> .....	91
<a href="#">Performing sequenced measurements</a> .....	91

#### Performing continuous measurements

When you measure continuously, the measurement is repeated until you deliberately stop it.

The duration of each individual measurement cycle (for example a single bargraph measurement) depends on the [measurement time](#) you have set for the measurement in question. After each measurement cycle, the data of the previous cycle is overwritten and replaced by the new data. Exception: When you are using a max or min hold function, the application keeps the highest or lowest values and replaces old data only if the current data contains a new maximum or minimum.

The R&S ESW allows you to select the measurement mode for the bargraph and the scan separately. When you select a continuous bargraph measurement, IF analysis (including the spectrogram) is also performed continuously. When you select a continuous scan, the scan spectrogram is also updated continuously. Running a continuous final measurement is not possible.

- ▶ To start a continuous scan, press either the [RUN CONT] key on the front panel or the "Continuous Scan" softkey in the "Sweep" menu.
- ▶ To start a continuous bargraph measurement, press the "Continuous Bargraph" softkey in the "Sweep" menu.

**Note:** Pressing the [RUN CONT] key again interrupts the scan (see [Chapter 7.3.3.2, "Interrupting a Scan"](#), on page 110) and does not stop it.

Continuous measurements are the default measurement mode.

Remote command:

`INITiate<n>:CONTinuous` on page 428

`INITiate<n>[:IMMediate]` on page 429

### Performing single measurements

When you run a single measurement, the measurement is performed once and then stopped. The duration of the measurement depends on the [measurement time](#).

Note that a single measurement does not necessarily consist of a *single* measurement. A single measurement can consist of several measurements, whose number you can define with the [Scan Count](#). In that case, the measurement stops when all measurements defined by the scan count or bargraph count are done.

The R&S ESW allows you to select the measurement mode for the bargraph and the scan separately. When you select a single bargraph measurement, IF analysis also stops when the bargraph measurement stops. Note, however, that the time defined for a single bargraph measurement can result in more than one update of the IF analysis trace (including the IF spectrogram). When you select a single scan, the spectrogram update also stops when the scan stops, but it can consist of several new lines in the spectrogram, depending on the configuration.

- ▶ To start a single scan, press either the [RUN SINGLE] key on the front panel or the "Single Scan" softkey in the "Sweep" menu.
- ▶ To start a single bargraph measurement, press the "Single Bargraph" softkey in the "Sweep" menu.

**Note:** Pressing the [RUN SINGLE] key again interrupts the scan (see [Chapter 7.3.3.2, "Interrupting a Scan"](#), on page 110) and does not stop it.

### Note on performing continuous [sequenced measurements](#):

When you are using the sequencer, you can select the measurement mode for each measurement channel that is part of the sequence.

Thus, the "Single Scan" and "Single Bargraph" softkeys only control the measurement mode for the currently selected measurement channel (for a channel defined sequence). In addition, the [RUN SINGLE] key in that case controls the sequencer, not a particular channel.

Remote command:

`INITiate<n>:CONTinuous` on page 428

Single scan or bargraph: `INITiate<n>[:IMMediate]` on page 429

Single final measurement: `INITiate<n>:FMEasurement` on page 429

Single test sequence: `INITiate<n>:EMITest` on page 429

### Performing sequenced measurements

When you run a sequenced measurement, you can combine measurements of several applications into a sequence of measurements. This sequence of measurements is either performed once (single sequence), indefinitely (continuous sequence) or a mixture of both (channel defined sequence).

For more information regarding the general functionality of the sequencer, see [Chapter 6.4, "Running a Sequence of Measurements"](#), on page 85.

In the receiver application, you can select whether to:

- Run a bargraph measurement each time the receiver application has its turn.
- Run a scan each time the receiver application has its turn.
- Skip measurements in the receiver application.

When you include the bargraph measurement in the sequence, IF analysis (including the spectrogram) is also done. When you include the scan in the sequence, spectrogram data is also collected (and a peak search and a final measurement are performed when you have defined a [test sequence](#) that covers these measurements).

Note the following effects of performing a scan in a sequence of measurements.

- Stopping a scan or final measurement aborts that measurement and resumes the measurement sequence in the next channel.
- Interrupting a scan is not possible.
- Interactive final measurements are not available.

**Tip:** Performing a *continuous* sequence with a *single* (bargraph or scan) measurement resets max hold values every time the sequencer starts a measurement in that receiver channel. To keep max hold values, use continuous measurements in the channel.

► To select the measurement to include in a sequence, select [SWEEP] > "Sequencer" until the required measurement is highlighted blue.

If you want to include a bargraph measurement *and* a scan in the sequence of measurements, you have to use two measurement channels.

Remote command:

See [Chapter 13.5.2, "Measurement Sequences"](#), on page 430.

## 7.2 Bargraph Configuration

**Access:** [MEAS CONFIG] > "Bargraph Config"

Alternatively, you can access the dialog box by clicking on the bargraph once.

The bargraph result display is designed for measurements on a single frequency. It is a basic result display that shows the signal level at a particular frequency numerically and graphically as a bargraph. The length of the bar depends on the signal level at the current receiver frequency. If necessary, you can control the way the signal is evaluated by selecting different detectors.

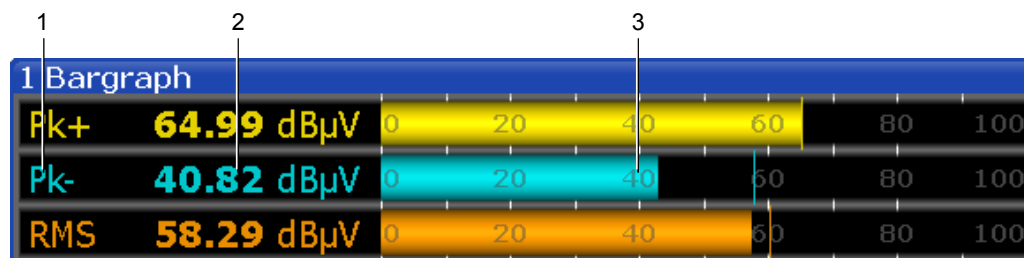

Figure 7-1: Overview of the bargraph result display

- 1 = detectors
- 3 = measured levels (numerically)
- 4 = measured levels (graphically)

The results in the bargraph are shown as soon as you enter the receiver application (for the frequency that is currently selected) and are updated continuously. The unit of the displayed power level is variable and depends on the unit you have set (by default, it is dB $\mu$ V).

The bargraph range is always 100 dB, the minimum and maximum levels that are displayed are automatically adjusted, depending on the measurement configuration. When auto ranging has been turned off, the range depends on settings like the attenuation or gain. When auto ranging has been turned on, the range is adjusted to the signal level.

The R&S ESW supports the simultaneous use of up to four different detectors in the bargraph result display. If you select an additional detector, the R&S ESW adds the corresponding number of bargraphs to the result display. This way to display the signal levels provides an easy way to compare the signal level with different weighting factors.



#### Meaning of small vertical lines in the bargraph



Depending on the configuration, the following small vertical lines can appear in the bargraph.

- A small vertical line with the same color as the bargraph shows the highest value that has been measured on the currently selected frequency.
- A small red vertical line with an "SQ" label shows the [squelch level](#) that you have defined for audio output over headphones.

#### Max hold bargraph

The max hold bargraph information, when it has been turned on, shows the highest signal level that has been measured since the measurement has begun. The max hold value remains effective, even if you change any receiver settings (for example the frequency or the attenuation) and is only reset when you deliberately do so. One max hold value is displayed for each of the active detectors.

When you turn on the max hold information, the diagram information is expanded by the peak level that has been measured since the max hold has been last reset (as a numerical value and including the frequency that value has been measured on). If a new peak level has been detected, the max hold values are updated accordingly.

The live results and the highest signal level for a particular frequency are still shown in the bargraph diagram as usual.



### Min peak detector levels

Note that for the min peak detector, the peak level is not the highest level, but the lowest level.

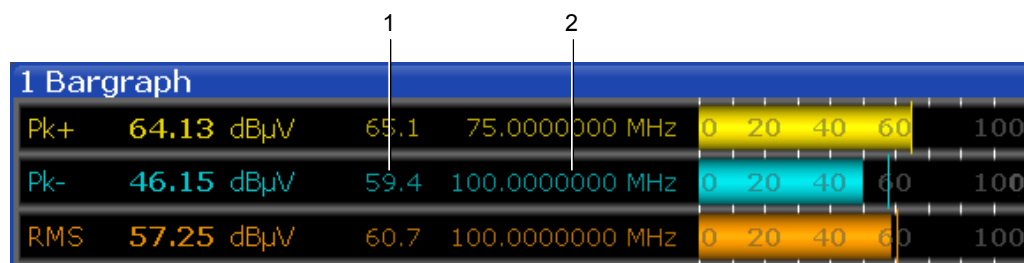

Figure 7-2: Screen layout of the bargraph result display with the max hold information

1 = maximum levels

2 = frequency on which the maximum level has been measured; note that the minimum and RMS peaks have been measured at frequency different to the current receiver frequency

The "Bargraph" dialog box contains a preview of the measurement and all settings that you can apply to the bargraph.



### Bargraph configuration

When you are performing a scan that is not based on a scan table, the R&S ESW applies the bargraph settings (detector, measurement time etc.) to the scan.

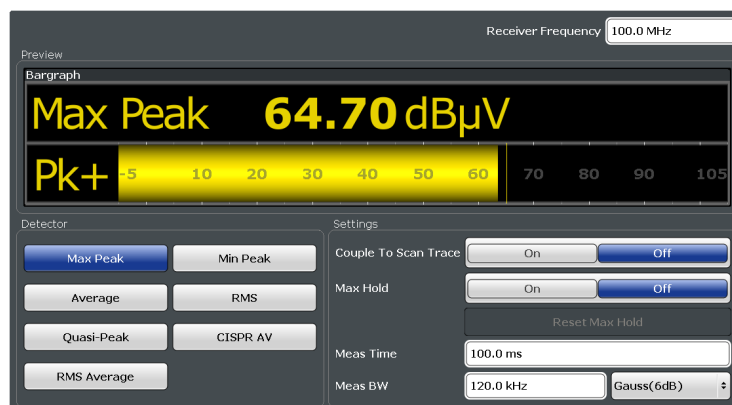

The remote commands required to configure the bargraph are described in [Chapter 13.5.4, "Bargraph Configuration"](#), on page 438.

Functions to configure the bargraph described elsewhere:

- ["Receiver Frequency"](#) on page 171
- ["Detector"](#) on page 127

Couple to Scan Trace.....	95
Bargraph Max Hold.....	95
Measurement Time.....	95
Measurement Bandwidth.....	96
Filter Type.....	96

### Couple to Scan Trace

Couples or decouples the bargraph detector and scan detectors.

Turning on the feature has the following effects.

- Turns on a scan detector for every active bargraph.  
If you add a new bargraph detector, the corresponding scan trace is automatically turned on.
- Matches the scan trace number to the number of the bargraph.

If you couple bargraph and scan trace, the R&S ESW replaces the detectors of all other active scan traces with the new detector type.

Remote command:

`DISPlay:BARGraph:TCoupling[:STATe]` on page 439

### Bargraph Max Hold

Turns the display of the highest level that has been measured on any frequency since the last "Max Hold Reset" on and off, regardless of the receiver settings.

When you turn on the max hold information, the R&S ESW shows the highest level that has been measured for each active bargraph (detector), including the frequency where it was measured.

**Note:** The little vertical line displayed in the bargraph does not represent the max hold value. Instead it shows the highest level that has been measured for the current receiver frequency.



You can reset the max hold bargraph with the "Reset Max Hold" button. After you have reset the max hold bargraph, it starts collecting maximum values again.

#### More information

Remote command:

Bargraph state: `DISPlay:BARGraph:PHOLd[:STATe]` on page 438

Bargraph reset: `DISPlay:BARGraph:PHOLd:RESet` on page 438

### Measurement Time

Defines the measurement time used to analyze the signal.

You can define a different measurement time for the bargraph, each scan range defined in the scan table and the final measurement. If you perform a scan that is not based on a scan table ([Current](#) parameters), the measurement time for the scan is the same as for the bargraph.

In addition, you can define a separate measurement time for fixed frequency scans.

**Tip:** Make sure to select a measurement time that is appropriate for the analyzed signal and that allows the various filters and detectors in the signal path to settle.

Note that the measurement time for IF analysis is calculated automatically based on the measurement time of the bargraph.

Remote command:

Bargraph: `[SENSe:]SWEep:TIME` on page 440

Scan table: `[SENSe:]SCAN<sr>:TIME` on page 449

Final measurement: `[SENSe:]FMEasurement:TIME` on page 462

Fixed frequency scan: `[SENSe:]SCAN<sr>:TDOMain` on page 441

CISPR APD: `[SENSe:]SWEep:TIME` on page 440

### Measurement Bandwidth

Defines the measurement bandwidth (or resolution bandwidth) used for the measurement.

You can define a different bandwidth for the bargraph and each scan range defined in the scan table. The R&S ESW displays an exclamation mark if the selected measurement bandwidth is not compatible to the bandwidth required by CISPR for the corresponding frequency range.

If you perform a scan that is not based on a scan table, the bandwidth for the scan is the same as for the bargraph.

The final measurement uses the bandwidths defined in the scan table, or, if the scan is not based on a scan table (**Current** parameters), the bandwidth of the bargraph.

The R&S ESW supports a selected set of resolution bandwidths. If you enter a number that is not supported, the R&S ESW rounds the value up to next available bandwidth.

#### More information

Remote command:

Bargraph: `[SENSe:]BANDwidth[:RESolution][:VALue]` on page 498

Scan table: `[SENSe:]SCAN<sr>:BANDwidth:RESolution` on page 444

CISPR APD: `[SENSe:]BANDwidth[:RESolution][:VALue]` on page 498

### Filter Type

Selects the type of resolution filter used in the measurement.

The available resolution bandwidths depend on the filter selection.

You can select from the following filter types.

- **Normal (3 dB)**  
Gaussian filter with a 3 dB bandwidth.
- **Gauss (6 dB)**  
Gaussian filter with a 6 dB bandwidth. 6 dB bandwidths that comply with CISPR and MIL standards are available.
- **CISPR (6 dB)**  
Gaussian filter with a 6 dB bandwidth. 6 dB bandwidths that comply with CISPR standards are available.
- **MIL (6 dB)**  
Gaussian filter with a 6 dB bandwidth. 6 dB bandwidths that comply with military standards are available.

6 dB bandwidths correspond approximately to the pulse bandwidth.

3 dB bandwidths correspond approximately to the noise bandwidth.

#### More information

Remote command:

[SENSe:]BANDwidth[:RESolution]:TYPE on page 499

## 7.3 Test Automation

**Access:** "Overview" > "Test Automation"

The "Test Automation" dialog box is a tool to configure and perform measurements in the Receiver application. The dialog box contains a tab for each typical stage in an EMC measurement (scan, peak search and final measurement). The dialog box also summarizes the measurement results for these stages in separate tabs.

- [Background Information](#).....97
- [Selecting a Test Sequence](#).....106
- [Performing a Scan](#).....109
- [Performing a Peak Search](#).....117
- [Performing Final Measurements](#).....124
- [Configuring Line Impedance Stabilization Networks \(LISN\)](#).....129

### 7.3.1 Background Information

The following topics contains information that can be useful to configure automated test sequences.

- [Selecting the Measurement Bandwidth](#).....97
- [Calculating the Number of Measurement Points](#).....98
- [Line Impedance Stabilization Network \(LISN\) Control](#).....100
- [Overview of Receiver Measurements](#).....102

#### 7.3.1.1 Selecting the Measurement Bandwidth

The measurement bandwidth corresponds to the bandwidth of the resolution filter. The RF signal is evaluated and displayed according to the bandpass characteristics of the resolution filter.

The receiver application supports the following types of resolution filter.

- Filters with a 3 dB bandwidth  
The R&S ESW provides bandwidths with a stepsize of 1-2-3-5-10-.... For details, refer to the data sheet.
- Filters with a 6 dB bandwidth  
The 6 dB bandwidths are designed and required for receiver tests and measurements. The R&S ESW provides bandwidths that comply to commercial and military standards. For details, refer to the data sheet.

Note that the available bandwidth is limited by the current receiver frequency. The measurement bandwidth must be less than or equal to half of the current receiver frequency:

$$BW \leq f_{in} / 2$$



The resolution filters are implemented as digital Gaussian bandpass filters. Concerning the attenuation characteristic, the filters behave like analog filters, but their measurement speed is much higher than the measurement speed of comparable analog filters. This is because the transient response can be compensated because the filters have an accurately defined behavior.

The highest sensitivity is obtained at the smallest bandwidth. If the bandwidth is increased, the reduction in sensitivity is proportional to the change in bandwidth. Increasing the bandwidth by a factor of 3 increases the displayed noise by approx. 5 dB (4.77 dB precisely). If the bandwidth is increased by a factor of 10, the displayed noise increases by a factor of 10 (= 10 dB).

The higher spectral resolution with smaller bandwidths leads to longer measurement times at each frequency, because the measurement time has to allow the resolution filters to settle during a sweep at all signal levels and frequencies to be displayed.

For large measurement bandwidths, signal parts that are very far away (for example from a different signal) are considered in the measurement and distort the results. The displayed noise increases.

For small measurement bandwidths, the measurement time increases.



#### **Bandwidths and detectors**

If you use the Quasipeak, CISPR Average or RMS Average detector, the R&S ESW by default couples the resolution bandwidth to the receiver frequency.

If you need a different bandwidth, you can decouple the bandwidth from the frequency. When decoupled, you can select any of the supported CISPR bandwidths.

---

### **7.3.1.2 Calculating the Number of Measurement Points**

The number of measurement points (or sweep points in some applications) determines the amount of data that is captured in one measurement. At each measurement point, the R&S ESW collects one set of data, which contains, for example, the signal level at a given frequency.

The effect of the number of measurement points on the measurement is that its number defines how much of the entire span is covered by a single data point.

#### **Example:**

Consider the following settings:

- Start frequency: 100 MHz
- Stop frequency: 900 MHz
- Number of measurement points: 1001

With said settings, each measurement point would cover a frequency range of about 800 kHz.

By increasing the number of measurement points, you can increase the reliability of the individual data points and thus the accuracy of the analyzed results. All of these data

points are stored on the instrument, occupying a large amount of memory, and each measurement point increases the overall measurement time.

For details on how the number of measurement points affect the trace results on the screen, see [Chapter 9.3.1.1, "Working with Trace Detectors"](#), on page 190.

### Measurement points in receiver application

In the receiver application, the number of measurement points considered in a scan is determined by the frequency range and the selected frequency step size: the R&S ESW runs a measurement every  $x$  Hz, so the actual number of measurement points depends on frequency range you are scanning. The maximum number of measurement points that a scan supports is 10,000,001 (this is only possible with two or less active traces).

The frequency step size depends on the frequency step mode and the type of scan you are using.

- **Scans without a scan table:**  
The frequency step size depends on the measurement bandwidth.

#### Example:

Consider the following scan configuration:

- Start frequency: 150 kHz
- Stop frequency: 1 MHz
- Measurement bandwidth: 1 kHz

The measurement bandwidth of 1 kHz results in a frequency step size of 400 Hz. In that case, the number of measurement points in this example would be about 2100.

- **Scans with a scan table:**  
The frequency step size is either determined automatically (in which case it depends on the measurement bandwidth) or manually (in which case you define the required step size)

#### Example:

Consider the following scan table settings for a given scan range:

- Start frequency: 150 kHz
- Stop frequency: 30 MHz
- Step size mode: linear
- Step size: 4 kHz

With said settings, the R&S ESW collects a dataset every 4 kHz, so the number of measurement points in this example would be about 7500.

### Measurement points in spectrum application

In the spectrum application, a measurement point is called a sweep point. Instead of determining the number of measurement points based on other settings, you can select the number of measurement points manually. By default, the R&S ESW measures 1001 points in one measurement.

For spectrum measurements, you can also define a sweep count. The sweep count defines the number of measurements a single sweep is made up out of. If the sweep count is 0 or 1, the R&S ESW runs a single measurement from start to stop frequency. If the sweep count is greater than 1, the R&S ESW repeats the measurement from start to stop frequency a corresponding number of times.

For more information on the effects of the sweep count on the measurement results, see [Chapter 9.3.1.2, "Analyzing Several Traces - Trace Mode"](#), on page 195.

### 7.3.1.3 Line Impedance Stabilization Network (LISN) Control

When you do measurements on power lines, a Line Impedance Stabilization Network (LISN) allows you to determine the interference caused by power supplies and cables. The R&S ESW allows you to connect and control selected LISNs in such a test setup and considers the characteristics of the LISN during measurements. In addition to selecting a particular [LISN Type](#), you can also select the [Phase](#) that you want to test for interference.

Control of a LISN and its phases is possible during scans and during the final measurement. You can control all available LISN phases as required and independently from each other.

If you select more than one phase, the R&S ESW measures all phase combinations and determines the maximum value.

**Table 7-1: Supported networks and controllable phases**

Network	Controllable phases
Two-line V-networks	
R&S ESH3-Z5	N, L1
R&S ENV216	N, L1
Four-line V-networks	
R&S ESH2-Z5	N, L1, L2, L3
R&S ENV4200	N, L1, L2, L3
R&S ENV432	N, L1, L2, L3

When you are using the R&S ENV216 network, you can protect the input with a 150 kHz [high-pass filter](#).

#### Connecting a LISN

A LISN is connected to the R&S ESW via its user port. To connect the LISN to the R&S ESW, a control line and an adapter are required.

The control line (or cable) controls which phase of the LISN is to be tested and outputs the information to the user port. Control lines for the supported LISNs are available as accessories from Rohde & Schwarz.

Connecting the control line to the user port of the R&S ESW also requires adapter R&S EZ-27 (order no. 1142.8271.02).

When you connect the LISN, make sure to use the correct pins on both sides of the test setup. Otherwise, the automatic phase control of the LISN might not work. The following illustrations show the correct pin assignment.

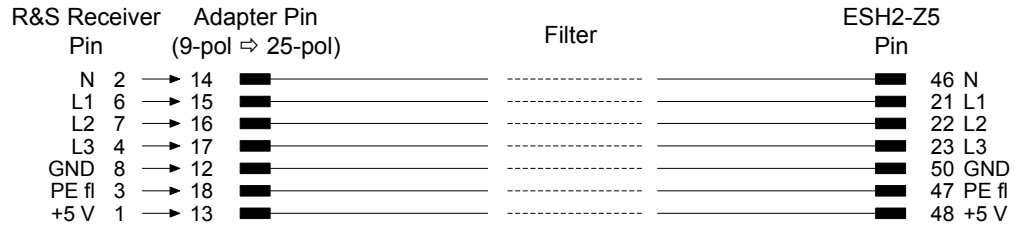

Figure 7-3: Connection from R&S ESW to R&S ESH2-Z5

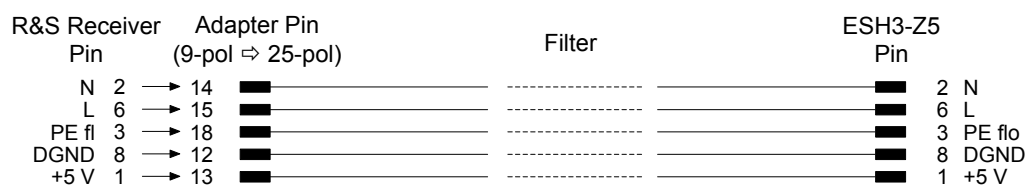

Figure 7-4: Connection from R&S ESW to R&S ESH3-Z5

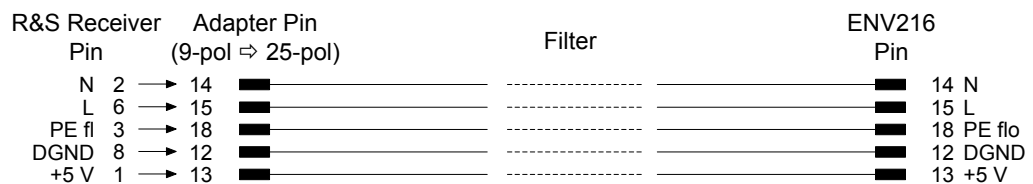

Figure 7-5: Connection from R&S ESW to R&S ENV216

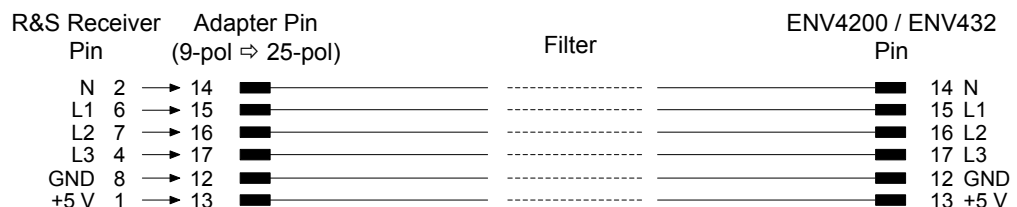

Figure 7-6: Connection from R&S ESW to R&S ENV4200 or R&S ENV432

To control the phase selection and PE simulating network of the V-Networks R&S ESH2-Z5, R&S ESH3-Z5, R&S ENV4200 or R&S ENV432, the +5 V supply voltage and some control lines have to be routed through the wall of the shielded room.

You can also use a direct connection without a filter, e.g. when you use the R&S ESW in a shielded room. In that case, you can use the following cables.

- R&S ESH2-Z5: EZ-5, EZ-13, EZ14
- R&S ESH3-Z5: EZ-6, EZ-14
- R&S ENV216: EZ14
- R&S ENV4200 or R&S ENV432: EZ-14, EZ-21

### 7.3.1.4 Overview of Receiver Measurements

The Receiver application provides several measurements and evaluation methods that are typical for EMC measurements.

- [Scan](#)..... 102
- [Peak Search](#)..... 103
- [Final Measurement](#)..... 105
- [IF Analysis](#)..... 105

#### Scan

During a scan, the R&S ESW measures the signal strength of discrete frequencies over a custom frequency range. The frequency step size and measurement time for each frequency are arbitrary.

The scan parameters are either based on the current receiver settings or on the settings defined in a [Scan Table](#). You can take transducer factors or sets as well as limit lines into account. They can be defined and displayed separately, but are not included in the scan data record.

The scanned frequency range is defined by the start and stop frequency set independently of the scan table. A scan table can thus be defined for each measurement task.

You can either perform a continuous scan or a single scan. A single scan stops when it reaches the stop frequency. A continuous scan repeats the scan until you interrupt or abort it deliberately.

The maximal number of measured frequencies is limited to 4.000.000 per detector. The data can be stored for postprocessing. If the scan subranges are defined so that more than the possible values would be measured, a respective message is output upon the scan start. Afterwards the scan is performed up to the maximum value.

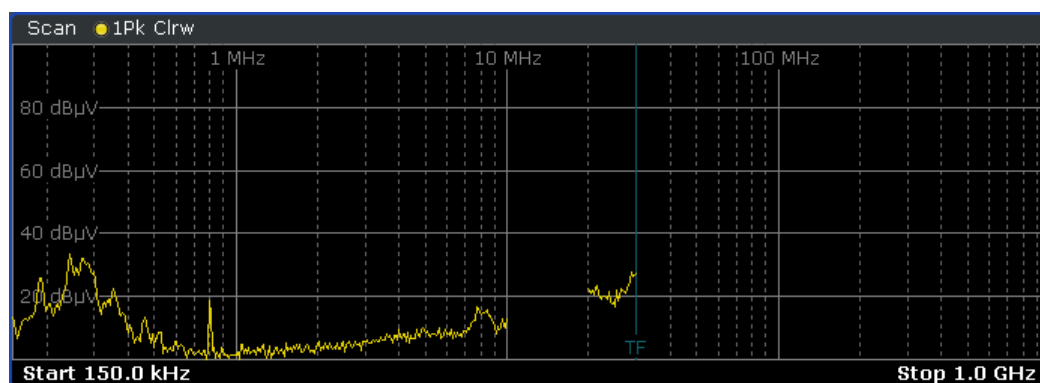

Figure 7-7: Scan on selected frequencies showing gaps in the trace

The R&S ESW offers the following scan methods:

- **Stepped scan in the frequency domain**  
In stepped scan mode, step width and frequency spacing (step mode) can be selected.
- **Time domain scan in the frequency domain**

In time domain measurement systems, the spectrum at the receiver input is measured in parallel by using fast fourier transform (FFT) of frequency sections.

- **Fixed frequency scan on a single frequency**

This scan is carried out on a fixed frequency. It is used to examine the time characteristics of interferences, e.g. click analysis.

### Stepped Scans in the Frequency Domain

In stepped scan mode, the step width and the frequency spacing (step mode) can be selected. Linear, logarithmic or automatic frequency spacing is available. In automatic mode, the step width is selected so that it is always smaller than the bandwidth.

Receiver measurements may involve much time. Time saving procedures are explained in "[Peak Search](#)" on page 103. They reduce the total measurement time by reducing the number of measurements to a minimum.

Nevertheless, this time is still very long, often in the order of hours, especially for the CISPR radiated emissions tests. A way out of this situation can be time-domain measurements.

### Peak Search

The Peak Search function of the R&S ESW can be used to create a peak list containing only the measurement values of high interferers. In a fast prescan the signal is measured against a limit line, and the level values above the set margin are written into the peak list. The resulting peak list then is used for the final measurement where only the frequencies in the peak list are measured with the required detector.

If the scan uses the detector stipulated by the specifications, the peak list already provides the final measurement data.

### Data Reduction using the Peak List

EMI measurements may take some time because the time constants of up to 160 ms prescribed by the standard for the quasipeak weighting lead to long measurement times per each value. In addition, some standards stipulate procedures for finding local EMI maxima such as shifting the absorbing clamp, variation of the test antenna height and rotating the DUT. Measuring with quasipeak weighting at each frequency and for each setting of the test configuration would lead to unacceptably long measurement times. For this reason, a method is used which reduces the time-consuming measurements to a minimum with an optimum reliability of detection.

Receiver measurements may take some time because of some specialties in the context of those measurements like variations of the test antenna or high time constants required by detectors or things like that. Because of this, the Receiver provides tools that reduce the efforts to a minimum while still providing an optimum measurement reliability.

The interference spectrum is first pre-analyzed in a fast prescan to optimize the duration of the measurement. Data reduction follows so that the time-consuming final measurement is performed only at critical frequencies.

Several data reduction methods are used:

- Generating subrange maxima (search method "Subranges").  
The whole frequency range is divided into equidistant frequency subranges. A selectable number of subrange maxima are determined for each subrange. In the final measurement, the interference spectrum is further analyzed at frequencies with the highest interference level of a frequency subrange.

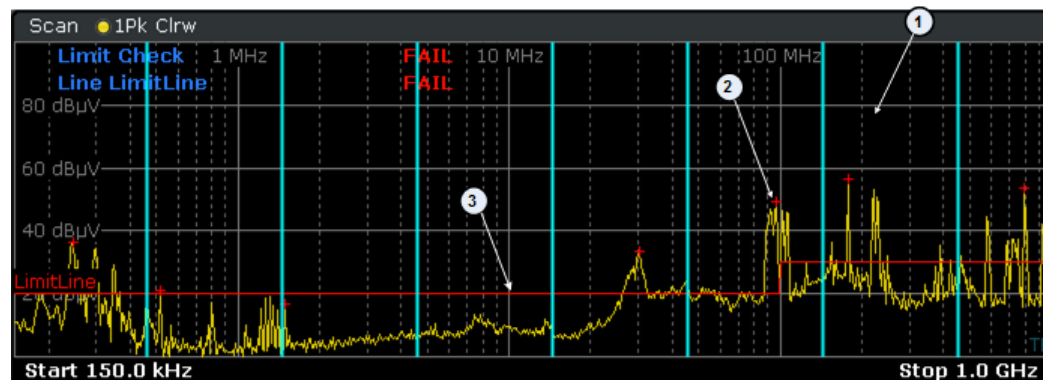

- 1 = Subrange
- 2 = Subrange maximum
- 3 = Limit line

- Determination of a specific number of peak values relative to the limit lines with the level values being independent of their frequency spectral distribution (search method "Peaks").  
Determining the level maxima irrespective of their distribution in the frequency spectrum is suitable for measurement regulations that demand determination of the relatively highest level irrespective of the distribution in the measured frequency range, e.g. FCC.

If the prescan is performed in parallel with several detectors, typically Peak and Average, the maxima are determined separately for the two detectors so that the distribution of narrowband and wideband sources of interference can be taken into account.

For example, the frequency of the maximum determined with the average detector can be used for the final measurement performed with the CISPR Avg detector and the frequency found in the prescan carried out with the peak detector is taken for the final measurement using the quasipeak detector.

Consideration of the limit lines ensures that the final measurement is not performed at frequencies at which the interference level is far below the limit value. A margin below the limit line can be defined (in dB). Peak values measured in the margin area are also considered in the final measurement. The margin is valid for all limit lines. Each limit line is allocated to a trace, i.e. different limit lines are taken for the different detectors.

If no limit lines are activated, the measurement procedure is as if all measured values would exceed the limit line.

#### Data Reduction by Editing the Peak List

As an alternative method, it is possible to preset a list of frequencies at which the final measurements are performed. A typical application is, for example, the statistical analysis of several units.

The peak list can be either edited manually or can be filled with desired values by adopting the marker values.

### **Final Measurement**

A final measurement is performed after data reduction, thus reducing the overall measurement time.

The final measurement analyzes only the data that still remains after the preliminary measurement stages, in other words those frequencies that have been collected in the peak list. Detectors defined for the final measurement replace those that have been used during preliminary measurements.

Because the peak list contains a manageable set of frequencies only, the final measurement is also usable in combination with a configuration that requires long measurement times. It is then still possible to perform the measurement in a reasonable time frame.

During the final measurement, the R&S ESW performs a measurement on each frequency in the peak list. When done, it updates the preliminary results in the peak list with those found during the final measurement.

### **Automatic vs interactive final measurements**

The R&S ESW provides two methods to perform a final measurement: an automatic and interactive final measurement.

An automatic final measurement measures all frequencies in the peak list automatically. The measurement can be interrupted or aborted, or the measurement mode can be switched to interactive. Measurement settings can not be changed. The advantage is that the measurement runs on its own.

Control of the final measurement is possible in interactive final measurement mode.

In interactive final measurement mode, the R&S ESW stops on each frequency of the peak list. If required, the frequency can be fine tuned, e.g. if the interferer has shifted. For fine tuning, the bargraph display can be used to find the new peak value. The level measurement is performed only after initialization by the user.

It is possible to start with an automatic measurement and later change into interactive mode. Likewise, it is possible to start measuring in interactive mode and later change into automatic mode.

### **IF Analysis**

The IF spectrum analysis is a very comfortable means for exact frequency tuning of the receiver and for identification of signals and of their bandwidth.

In IF spectrum analysis, the spectrum of the RF input signal is displayed in the vicinity of the receiver frequency. The center frequency of the displayed spectrum is always the current receive frequency.

The IF analysis provides a fast overview of the assignment of the spectrum adjacent to the measuring channel proper, or, with a large resolution bandwidth, the spectral distribution of a modulated signal in the channel. Interference of the received useful signal can also be detected quickly, whether it is CW interference appearing as unmodulated



carrier or pulse-like interference which is represented in the form of narrow horizontal lines on the screen.

The accuracy of the frequency axis corresponds to the reference used (internal or external).

In contrast to normal spectrum analyzer operation, the measured values are determined using FFT from samples recorded from the A/D-converter. Thus the receiver stays tuned to the center frequency. It may continue to measure with the selected measurement time and display the signal level with the bargraph.

(For example, the quasipeak level measured with one second measurement time may be displayed in the upper half of the display while in the lower half the spectrum may be refreshed every few milliseconds.)

The measurement time of the bargraph may be longer than the measurement time of the IF analysis. If the measurement time of the bargraph is set to a smaller value than the measurement time of the IF analysis, the bargraph will as often be refreshed as the display of the IF analysis.

The level display of the IF analysis is unweighted. It is independent of the selected detector for the bargraph measurement, e.g. average or quasi peak. A maximum of three traces can be displayed in parallel. The display mode "Clear / Write", "Max Hold", "Min Hold", "Average", "View" or "Blank" may be selected independent for each trace.



The displayed level values do have the full accuracy of the instrument only at the center frequency. At all other frequencies, the level is typically lower due to the frequency response of the IF filter and the preselector.

IF Analysis always applies resolution filters with a 6 dB bandwidth, while filters with a 3 dB bandwidth are not supported.

### 7.3.2 Selecting a Test Sequence

**Access:** "Overview" > "Test Automation" > "Overview"

The first tab of the "Test Automation" dialog box ("Overview") represents the measurement stages in an interactive diagram. You can add or remove certain stages from the measurement as required: you can, for example, configure a measurement that consists of a scan and a peak search, but no final measurement.

Possible combinations are:

- Perform a scan only.
- Perform a scan with a subsequent peak search and creation of the peak list.  
(Remote command: `CALCulate<n>:PEAKsearch:AUTO` on page 452)
- Perform a scan with a subsequent peak search and a final measurement including the creation of a final peak list.  
(Remote command: `CALCulate<n>:FMEasurement[:AUTO]` on page 460)

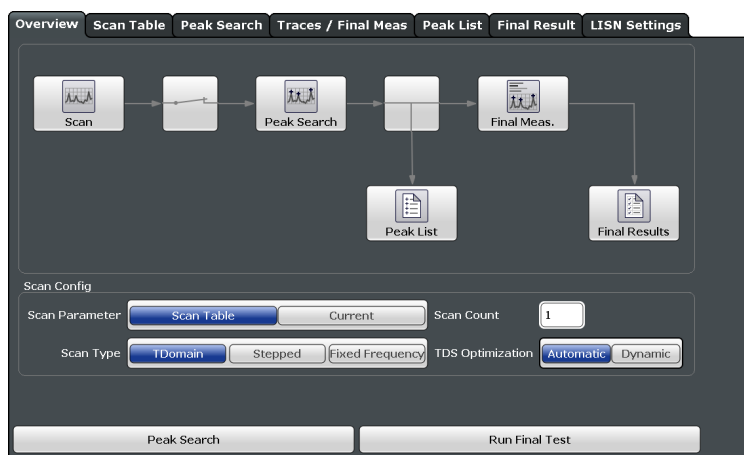

**Figure 7-8: Overview of the test automation process**

For more information on the individual measurement stages, see:

- **Scan**  
["Scan"](#) on page 102  
[Chapter 7.3.3, "Performing a Scan"](#), on page 109
- **Peak search**  
["Peak Search"](#) on page 103  
[Chapter 7.3.4, "Performing a Peak Search"](#), on page 117
- **Final measurement**  
["Final Measurement"](#) on page 105  
[Chapter 7.3.5, "Performing Final Measurements"](#), on page 124

### Starting a complete automated test sequence

- ▶ Press the [RUN SINGLE] key.

The R&S ESW starts the test sequence. It stops the test sequence at the point you have defined (either after the scan, the peak search or the final measurement).

**Note:** If you start the test sequence with the [RUN CONT] key, the R&S ESW starts a continuous scan. The test sequence is resumed only when you stop the scan deliberately.

### Starting an independent peak search

- ▶ Press the  button.

The R&S ESW starts a peak search on the current trace(s) of the scan diagram. When it is done, it opens the peak list.

If you have not yet performed a scan, the peak search button is unavailable.

### Starting an independent final measurement

- ▶ Press the  button.

The R&S ESW starts a final measurement based on the contents of the peak list. When it is done, it opens the final peak list.

If you have not yet performed a scan and peak search, the final measurement button is unavailable.

Selecting the scan type.....	108
Scan Count.....	108
Scan Parameter.....	108
Selecting the mode for time domain scans.....	109

### Selecting the scan type

The R&S ESW provides several scan types. Depending on the selected scan type, the R&S ESW applies different methods to evaluate the applied signal.

The following scan types are supported.

- **Stepped scan**  
Subsequent measurements on each individual frequency defined by the [frequency range](#) and the [frequency step size](#).  
(→ "Scan Type" > "Stepped")
- **Time domain scan**  
Simultaneous measurements based on FFT operations on all individual frequencies in the frequency range you have defined. The frequency step size is variable because it depends on the selected measurement bandwidth.  
(→ "Scan Type" > "TDomain")
- **Fixed frequency scan**  
Measurement on a single frequency and display of the results in the time domain. This mode is designed for measurements where the signal has to be monitored over time (for example click rate analysis).  
(→ "Fixed Frequency" > "On")  
When you turn on fixed frequency scans, scans in the frequency domain are not available.)

Remote command:

[SENSe:] FREQuency:MODe on page 440

### Scan Count

Defines the number of scans to be performed in a single measurement. The displayed trace represents an average over the scan count.

When you measure continuously, the R&S ESW calculates a moving average over the scan count.

The scan count is always the same as the "Bargraph Count" (and vice versa). The "Bargraph Count" defines the number of bargraph measurements performed in a single sweep.

Note that a scan count = 0 is not possible. The same applies to the bargraph count.

A scan count is not possible for [Fixed Frequency Scans](#).

Remote command:

[SENSe:] SWEEp:COUNT on page 449

### Scan Parameter

Turns the scan table on and off.

"Scan Table" The R&S ESW performs scans based on the configuration defined in the scan table.

"Current" The R&S ESW performs scans on the general receiver configuration. The scan table becomes unavailable.

Remote command:  
not supported

### Selecting the mode for time domain scans

The R&S ESW provides two time domain scan modes.

You can select the time domain scan mode with the "TDS Optimization" feature.

- **Automatic**

The effects of this mode depend on the detectors currently in use.

When you are using one of the CISPR detectors, the R&S ESW uses a small analysis bandwidth (FFT size) for the data capture in favor of a high dynamic range.

When you are using no CISPR detector, the R&S ESW uses a large analysis bandwidth (FFT size) for the data capture in favor of an increased measurement speed.

- **Dynamic**

The R&S ESW always applies a small analysis bandwidth in favor of a high dynamic range, regardless of the detector you are using.

Remote command:

[SENSe:]FREQuency:TDOPTim on page 441

## 7.3.3 Performing a Scan

- [Designing a Scan Table](#)..... 109
- [Interrupting a Scan](#)..... 110
- [Configuring the Scan Table](#)..... 111

### 7.3.3.1 Designing a Scan Table

The scan table is a tool that reduces the effort of performing a scan. It divides a given frequency range into smaller portions.

In that way you are able to:

- keep the measurement times as low as possible by creating several frequency ranges and configuring each one most effectively
- configure some frequency ranges differently than others if the test scenario requires so and still run one measurement only
- skip parts of the spectrum that are of no interest for the measurement.

If you do not use the scan table ([Current](#) parameters), the R&S ESW uses the current instrument settings for the scan.

You can define up to 100 scan subranges within the complete scan range. The size of each subrange is arbitrary, depending on the measurement requirements. Just make sure that the ranges are within the overall scan range defined by the general start and

stop frequencies. If the scan table defines a frequency range greater than the scan range, frequencies outside the scan range are not considered in the measurement.

To avoid situations like this, you can align the start and stop frequency of the scan to the frequency range defined by the scan ranges (see ["Adjusting the frequency axis"](#) on page 112).

#### Example:

In the picture below, the frequency range highlighted in red is covered by the scan table, but not by the overall scan range. Thus, it would not be considered in the scan.

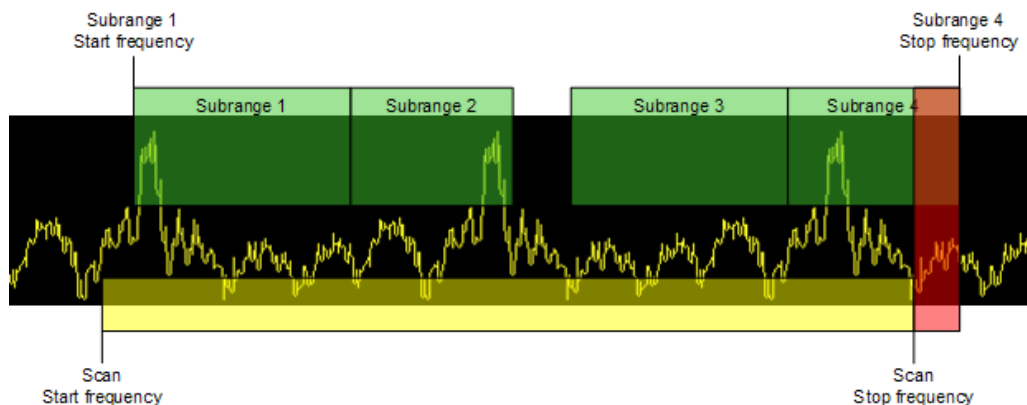

Figure 7-9: Scan range vs subranges of a scan

There may be gaps between the stop frequency of one range and the start frequency of the next, for example if parts of the spectrum are not necessary to be tested. Gaps between ranges are not considered in the scan.

### 7.3.3.2 Interrupting a Scan

**Access:** [RUN SGL] / [RUN CONT] > "Hold Scan"

The R&S ESW allows you to hold a scan any time with the "Hold Scan" feature. If you hold it, the scan is interrupted immediately. When held, you can change settings that have a direct effect on the scan, for example the frequency.

When you are finished changing the configuration, you have several options on how to proceed.

- Continue at the receiver frequency  
Resumes the scan at the receiver frequency the R&S ESW is currently tuned to. This is any frequency that is equal to or smaller than the hold frequency. If you do not change the frequency, resuming the scan at the receiver frequency is the same as resuming the scan at the hold frequency.
- Continue at the hold frequency  
Resumes the scan at the frequency it has been interrupted at. For example, when you interrupt the scan at 20 MHz, the scan would continue at that frequency.
- Stop the scan  
Aborts the scan altogether.



### Changing channels while a scan is running

When you change the measurement channel while a scan is running (for example switch to a spectrum channel), the R&S ESW holds the scan. When you change back to the receiver channel in which the scan is running, you can resume the scan from the hold frequency.

#### 7.3.3.3 Configuring the Scan Table

**Access:** "Overview" > "Test Automation" > "Scan Table"

By default, the scan table already contains two scan ranges with a typical configuration for these frequency ranges.

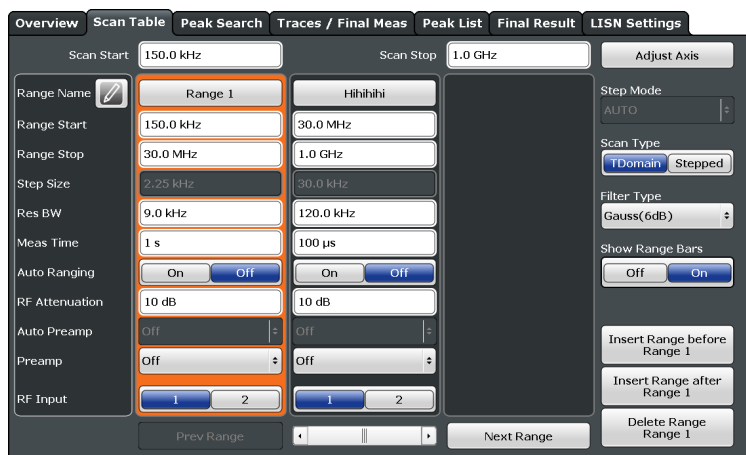

Figure 7-10: Overview of the "Scan Table"

The remote commands required to design a scan table are described in [Chapter 13.5.6, "Scan Table Configuration"](#), on page 442.

Functions in the "Scan Table" dialog box described elsewhere:

- [Scan Type](#)
- [Filter Type](#)

<a href="#">Adding and removing scan ranges.....</a>	112
<a href="#">Defining a frequency range for the scan.....</a>	112
<a href="#">Adjusting the frequency axis.....</a>	112
<a href="#">Selecting the frequency step mode.....</a>	113
<a href="#">Displaying range bars.....</a>	113
<a href="#">Configuring scan ranges.....</a>	113
L <a href="#">Range Start and Range Stop.....</a>	114
L <a href="#">Step Size.....</a>	114
L <a href="#">Measurement Bandwidth.....</a>	114
L <a href="#">Measurement Time.....</a>	115
L <a href="#">Auto Range.....</a>	115
L <a href="#">Attenuation.....</a>	116
L <a href="#">Preamplifier.....</a>	116
L <a href="#">Input Selection.....</a>	117

### Adding and removing scan ranges

The scan table splits the frequency range into several smaller ranges (up to 100 ranges).

By default, there are already two predefined scan ranges (labeled "Range 1" and "Range 2"). If necessary, you can add additional scan ranges or delete scan ranges that you no longer need.

You have the following options when you design the scan table.

- Add a new range to the left of the currently selected range (→ "Insert Range Before Range <x>" button).
- Add a new range to the right of the currently selected range (→ "Insert Range After Range <x>" button).
- Delete the currently selected range (→ "Delete Range <x>" button).  
(The selected range is the range that is highlighted in orange. To select a range, select the "Range x" button at the top of each column, or navigate through the ranges with the "Prev Range" or "Next Range" buttons.)

Remote command:

Number of ranges: `[SENSe:]SCAN<sr>:RANGes[:COUNT]` on page 447

**Tip:** Selecting a range via SCPI is done with the suffix at `SCAN<range>`.

Delete a range: not supported by remote control

### Defining a frequency range for the scan

The start and stop frequencies ("Scan Start" and "Scan Stop") define the global frequency range considered during a scan.

The minimum and maximum frequencies supported by the R&S ESW depend on the instrument model and are defined in the datasheet.

**Note:** Make sure that all scan ranges are within the global frequency range. Frequencies outside the global frequency range will not be considered in the measurement.

Remote command:

Start frequency: `[SENSe:]FREQuency:START` on page 443

Stop frequency: `[SENSe:]FREQuency:STOP` on page 443

### Adjusting the frequency axis

When you design a scan table, the frequency range of the scan ranges may not be the same as the global frequency range you have defined for the scan.

The "Adjust Axis" button adjusts the global frequency range to the frequency range covered by the scan ranges.

**Example:** the global frequency range defines a range from 150 kHz to 500 MHz, while the scan ranges define a range from 150 kHz to 1 GHz. When you adjust the frequency, the R&S ESW automatically expands the global frequency range to 1 GHz.

On the other hand, when the global frequency range is larger than the scan ranges, adjusting the frequency contracts the global frequency range.

This feature is useful when the global frequency range is smaller than the scan ranges, because frequencies outside the global range are not considered in a scan based on a scan table.

Remote command:

not supported

### Selecting the frequency step mode

The frequency step mode defines the way the measurement frequencies are selected within a scan range.

Note that the frequency stepsize for time domain scans is always selected automatically.

"AUTO"	Linear frequency steps: the <a href="#">Step Size</a> is coupled to the current resolution bandwidth and is about a third of the resolution bandwidth. In this way, the probability to detect all signals in the scan range is very high.
"LIN"	Linear frequency steps: the <a href="#">Step Size</a> is a fix value in Hz.
"LOG"	Logarithmic frequency steps: the <a href="#">Step Size</a> is a percentage of the current frequency.

Remote command:

[\[SENSe:\] SWEep:SPACing](#) on page 450

### Displaying range bars

The range bar is a green bar displayed at the bottom of the scan diagram. You can turn it on or off as you like with the "Show Range Bars" toggle button.

The range bar carries various useful information.

- The shade of green shows the measurement progress.
  - Dark green  
Indicates that the scan of the corresponding scan range is done.
  - Light green  
Indicates that the scan of the corresponding scan range is currently in progress.  
If you interrupt the scan, the bar remains light green. The bar of the last scan range also remains light green when the scan is done completely.
- The bar contains the names of the corresponding scan ranges as defined in the scan table (for example "Range 1", "Range 2", etc.).

Remote command:

[\[SENSe:\] SCAN<sr>:BARS](#) on page 444

### Configuring scan ranges

The main part of the scan table contains the configuration for each scan range. Each column of the table represents one scan range (labeled "Range 1", "Range 2", etc. by default).

You can change the labels of the scan ranges and assign a custom name to each range. When you select the pencil icon (✎), you can edit the range labels. To stop editing, select the pencil icon again.

For each scan range, you can customize the following parameters.

- ["Range Start and Range Stop"](#) on page 114
- ["Step Size"](#) on page 114
- ["Measurement Bandwidth"](#) on page 96
- ["Measurement Time"](#) on page 95
- ["Auto Range"](#) on page 115
- ["Attenuation"](#) on page 116
- ["Preamplifier"](#) on page 116



- "Input Selection" on page 117

Remote command:

[SENSe:] SCAN<sr>:NAME on page 447

### Range Start and Range Stop ← Configuring scan ranges

Defines the frequency range of the selected scan range.

To avoid overlapping scan ranges, the start and stop frequencies of the next and previous ranges are adjusted if necessary.

**Tip:** Make sure that the start and stop frequencies of the scan ranges are within the [global frequency range](#).

Remote command:

Start frequency: [SENSe:] SCAN<sr>:START on page 448

Stop frequency: [SENSe:] SCAN<sr>:STOP on page 449

### Step Size ← Configuring scan ranges

Defines the frequency step size of the selected scan range that is applied during a scan.

In case of a stepped scan, the value depends on the selected [step mode](#).

- When you have selected the automatic step mode, the step size is determined automatically. It is not possible to change the step size manually (however, it is displayed in the corresponding table cell as a read-only value).
- When you have selected the linear step mode, the step size is a value in Hz (a measurement is performed every x Hz).  
**Example:** a step size of 4 kHz and a start frequency of 100 kHz does a measurement at 100 kHz, 104 kHz, 108 kHz etc.
- When you have selected the logarithmic step mode, the step size is a value in % (the next measurement frequency is a percentage of the last frequency).  
**Example:** a step size of 10 % and a start frequency of 100 kHz does a measurement at 100 kHz, 110 kHz, 121 kHz etc.

For a time domain scan, the step size depends on the measurement bandwidth. It is displayed in the "Step Size" table cell as a read-only value.

Remote command:

[SENSe:] SCAN<sr>:STEP on page 448

### Measurement Bandwidth ← Configuring scan ranges

Defines the measurement bandwidth (or resolution bandwidth) used for the measurement.

You can define a different bandwidth for the bargraph and each scan range defined in the scan table. The R&S ESW displays an exclamation mark if the selected measurement bandwidth is not compatible to the bandwidth required by CISPR for the corresponding frequency range.

If you perform a scan that is not based on a scan table, the bandwidth for the scan is the same as for the bargraph.

The final measurement uses the bandwidths defined in the scan table, or, if the scan is not based on a scan table ([Current](#) parameters), the bandwidth of the bargraph.

The R&S ESW supports a selected set of resolution bandwidths. If you enter a number that is not supported, the R&S ESW rounds the value up to next available bandwidth.

#### More information

Remote command:

Bargraph: `[SENSe:]BANDwidth[:RESolution][:VALue]` on page 498

Scan table: `[SENSe:]SCAN<sr>:BANDwidth:RESolution` on page 444

CISPR APD: `[SENSe:]BANDwidth[:RESolution][:VALue]` on page 498

### Measurement Time ← Configuring scan ranges

Defines the measurement time used to analyze the signal.

You can define a different measurement time for the bargraph, each scan range defined in the scan table and the final measurement. If you perform a scan that is not based on a scan table (Current parameters), the measurement time for the scan is the same as for the bargraph.

In addition, you can define a separate measurement time for fixed frequency scans.

**Tip:** Make sure to select a measurement time that is appropriate for the analyzed signal and that allows the various filters and detectors in the signal path to settle.

Note that the measurement time for IF analysis is calculated automatically based on the measurement time of the bargraph.

Remote command:

Bargraph: `[SENSe:]SWEep:TIME` on page 440

Scan table: `[SENSe:]SCAN<sr>:TIME` on page 449

Final measurement: `[SENSe:]FMEasurement:TIME` on page 462

Fixed frequency scan: `[SENSe:]SCAN<sr>:TDOMain` on page 441

CISPR APD: `[SENSe:]SWEep:TIME` on page 440

### Auto Range ← Configuring scan ranges

Turns automatic configuration of the attenuation and gain on and off.

When you turn on auto ranging ("State"), the R&S ESW automatically selects an attenuation (and gain, if auto mode for the preamplifier is on) that allows for an ideal analysis of the received signal (without overloading the RF input).

Depending on your measurement task, select one of the following **auto range modes** ("Mode").

- **Normal**

The "Normal" mode selects an attenuation and gain that results in a good signal-to-noise ratio.

Thus, it reduces the display of spurious products. It also leads to an increased display of the inherent noise (because of a higher attenuation).

- **Low noise**

The "Low Noise" mode selects an attenuation and gain that increases the sensitivity of the R&S ESW.

This mode gives a better impression of spurious products and is thus useful to analyze signals whose level is near the noise level. However, the signal-to-noise ratio in general can deteriorate.

Both auto range modes are designed to maintain the best dynamic range possible.

The auto ranging feature in the receiver remains active even if you change the attenuation and preamplifier properties in other measurement channels and then return to the receiver application.

**Notice:** For more information, see [Chapter 8.5.1, "Increasing Measurement Sensitivity \(or Avoiding an Input Mixer Overload\)"](#), on page 162.

Remote command:

General: `INPut<ip>:ATTenuation:AUTO` on page 494

Scan range: `[SENSe:]SCAN<sr>:INPut:ATTenuation:AUTO` on page 445

Auto range mode: `INPut<ip>:ATTenuation:AMODE` on page 494

### Attenuation ← Configuring scan ranges

Defines the attenuation of the signal.

You can attenuate the signal in 1 dB steps. The range is specified in the datasheet. Attenuation of less than 10 dB is only possible if you turn off [10 dB Minimum Attenuation](#).

If you are using the preamplifier in frequency ranges above 8 GHz, the available attenuation can be reduced. For more information, see [Chapter 8.5.1.2, "Using the Preamplifier"](#), on page 164.

**Notice:** For more information, see [Chapter 8.5.1, "Increasing Measurement Sensitivity \(or Avoiding an Input Mixer Overload\)"](#), on page 162.

The auto ranging feature in the receiver remains active even if you change the attenuation and preamplifier properties in other measurement channels and then return to the receiver application.

The R&S ESW also allows you to determine the best attenuation automatically.

- In the receiver application, turn on the "Auto Ranging" feature.
- In the other applications, select attenuation "Mode" → "Auto"

Remote command:

Global: `INPut<ip>:ATTenuation` on page 494

Scan range: `[SENSe:]SCAN<sr>:INPut:ATTenuation[:VALUE]` on page 445

Attenuation mode: `INPut<ip>:ATTenuation:AUTO` on page 494

### Preamplifier ← Configuring scan ranges

Configures the preamplifier.

In addition to the standard preamplifier, a low noise amplifier is available as an optional hardware component.

You can configure the preamplifier manually (→ "Value" menu) or, if you are using the [Auto Range](#) functionality, let the R&S ESW pick the ideal configuration (→ "Auto" menu).

- **"Auto Off"**

Allows you to turn the preamplifier on and off manually as required. If you have the optional low noise preamplifier, you can select the preamplifier you would like to apply from the "Value" menu ("LN Amplifier" or "Preamp)", or turn it off completely.

- **"Auto LN Amplifier"**

Automatically turns the optional low noise amplifier on and off, depending on the applied signal. This is only possible when the "Auto Range" feature has been turned on.

- **"Auto Preamp"**

Automatically turns the preamplifier on and off, depending on the applied signal. This is only possible when the "Auto Range" feature (and the preselector) have been turned on.

Note that when you select a different setting in the "Value" menu while the "Auto" configuration is on, automatic configuration is turned off.

**Example:** "Auto" = "Preamp". When you select "Value" = "Preamp", "Auto" turns to "Off".

Using both preamplifiers at the same time is not possible.

Note that turning on one of the preamplifiers limits the lower frequency (see data-sheet for details).

Note that if you want to use the standard preamplifier, you have to route the signal through the preselector.

[More information.](#)

Remote command:

**Preamplifier:**

State (global): `INPut<ip>:GAIN:STATE` on page 496

State (scan range): `[SENSe:]SCAN<sr>:INPut:GAIN[:STATE]` on page 446

Mode (global): `INPut<ip>:GAIN:AUTO` on page 495

Mode (scan range): `[SENSe:]SCAN<sr>:INPut:GAIN:AUTO` on page 445

**Low noise preamplifier:**

State (global): `INPut<ip>:GAIN:LNA:STATE` on page 496

State (scan range): `[SENSe:]SCAN<sr>:INPut:GAIN:LNA:STATE` on page 446

Mode (global): `INPut<ip>:GAIN:LNA:AUTO` on page 495

Mode (scan range): `[SENSe:]SCAN<sr>:INPut:GAIN:LNA:AUTO` on page 446

### Input Selection ← Configuring scan ranges

Selects the RF input connector you would like to use for a measurement.

Note that you cannot use both RF inputs simultaneously.

Remote command:

Global: `INPut<ip>:TYPE` on page 474

Scan range: `[SENSe:]SCAN<sr>:INPut:TYPE` on page 447

## 7.3.4 Performing a Peak Search

A peak search is meant to find signal peaks in the spectrum that you are analyzing. The results of the peak search are written into a peak list, which in turn is the basis for a final measurement.

This approach reduces the efforts required for the final measurement in that you have to test only a few selected frequencies that probably carry interfering signals.

### Defining peak characteristics (or "When is a peak a peak?")

If a signal is, for example, very flat, contains a lot of noise or does not contain many peaks, the R&S ESW might miss potential peaks or detect peaks that really are no peaks.

To avoid such situations, you can define what a peak is according to the following criteria.

- **Peak excursion**  
The peak excursion is a relative threshold. The signal level must increase by the threshold value before falling again before a peak is detected.  
To avoid identifying noise peaks instead of a real signal peak, enter a peak excursion that is higher than the difference between the highest and the lowest value measured for the displayed inherent noise.
- **Limit lines** (not mandatory)  
The signal level must be above the limit line (= fail the limit check) to be considered as a peak.
- **Limit margin** (only if a limit line is active)  
The level margin defines the distance relative to a limit line that a signal may at most have so that it will be identified as a peak.

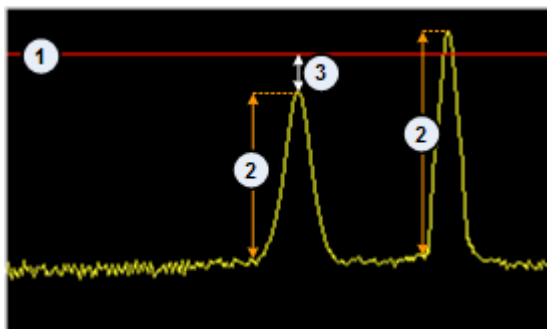

Figure 7-11: Peak definition

- 1 = Limit line
- 2 = Peak excursion
- 3 = Limit margin

Thus, a potential peak is written into the peak list under the following conditions.

#### Measurements without limit lines:

- If a signal meets the condition defined by the peak excursion.

#### Measurements with limit lines:

- If a signal level fails a limit check and meets the condition defined by the peak excursion.
- If a signal level passes a limit check, but is within the limit margin ("x dB below the limit"), and still meets the peak excursion.

In the diagram, the peaks are labeled with a colored symbol. Color and type of symbol depend on the trace the peak is on.

**Selecting the search method (or "How the search is performed?")**

The automatic peak search that is part of automated tests is an easy way to find peaks: the R&S ESW searches for peaks after the scan is done based on the conditions you have defined for the peak search (peak excursion and limit margin). It then writes the peaks into the peak list.

Alternatively, the R&S ESW allows you to edit peak lists and manually add or delete frequencies. To create a peak list manually, you can, for example, use markers to search for peaks, or, if you already know where peaks occur, add each frequency individually.

**Controlling the size of the peak list**

The size of the peak list is variable. The peak list can contain up to 500 entries (= frequencies). By default, the peak search adds peaks until the maximum size of the peak list has been reached and regardless of the distribution of the peaks. If there are more peaks than the size of the peak list allows for, the R&S ESW removes the frequencies with the smallest signal levels. If there are fewer peaks than the list allows for, the size of the list is reduced accordingly.

The R&S ESW also provides the possibility to split the spectrum into several equidistant subranges and look for a defined number of peaks in each subrange with the result that peak list entries are distributed equally over the measurement range.

- [Configuring a Peak Search](#)..... 119
- [Modifying a Peak List](#)..... 121
- [Modifying a Peak List \(Alternate Method\)](#)..... 124

**7.3.4.1 Configuring a Peak Search**

**Access:** "Overview" > "Test Automation" > "Peak Search"

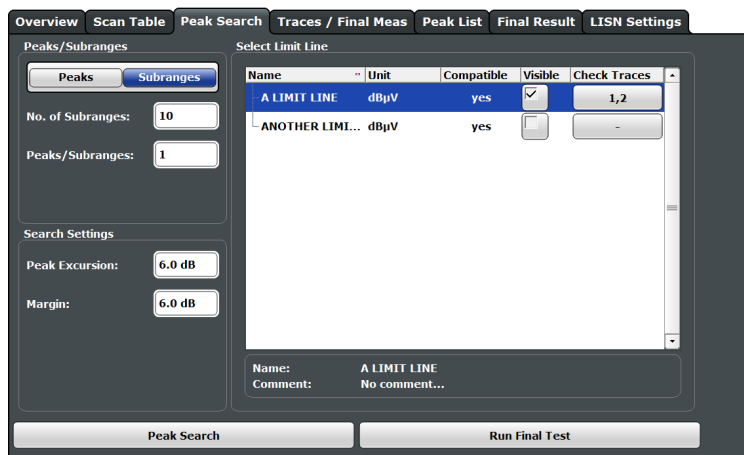

*Figure 7-12: Overview of the "Peak Search" configuration*

The remote commands required to configure the peak search are described in [Chapter 13.5.7, "Peak Search"](#), on page 450.

Selecting the peak search method.....	120
Controlling the size of the peak list.....	120
Defining peak characteristics.....	120
Selecting a limit line.....	121

### Selecting the peak search method

Selects the peak search mode.

[More information.](#)

- |             |   |
|-------------|---|
| "Peaks"     | Looks for a particular number of peaks over the complete scan range.  |
| "Subranges" | Divides the scan range into smaller, equidistant subranges and looks for a particular number of peaks in each subrange. |

Remote command:

[CALCulate<n>:PEAKsearch:METHOD](#) on page 453

### Controlling the size of the peak list

Defines the number of peaks that are transferred to the peak list.

The contents of the peak list depend on the selected [search mode](#).

- **"Peaks"**  
When you have selected the "Peaks" search mode, define the **number of peaks** the R&S ESW looks for during a peak search.  
The range is from 1 to 500 peaks.
- **"Subranges"**  
When you have selected the "Subranges" search mode, define the **number of subranges** you want to split the frequency range into, and the **number of peaks** the R&S ESW looks for in each subrange.  
You can define up to 50 subranges, with each subrange containing a maximum number of 10 peaks. All subranges span the same frequency range.

Remote command:

Number of peaks: [CALCulate<n>:PEAKsearch:SUBRanges](#) on page 454

Number of subranges: [CALCulate<n>:PEAKsearch:SUBRanges](#) on page 454

Peaks per subrange: [CALCulate<n>:PEAKsearch:SUBRanges:PCOUNT](#) on page 453

### Defining peak characteristics

Defines the characteristics of a signal that identify it as a peak.

The **peak excursion** defines the minimum level by which a signal must rise or fall so that it will be identified as a maximum or a minimum during the peak search.

The **margin** defines the distance relative to a limit line that a signal may at most have so that it will be identified as a peak.

(Note: a limit line margin defined for the limit line itself (see [Margin](#)) is ignored for a peak search.)

For more information, see ["Defining peak characteristics \(or "When is a peak a peak?"\)"](#) on page 118.

Remote command:

Peak excursion: [CALCulate<n>:MARKer<m>:PEXCursion](#) on page 451

Margin: [CALCulate<n>:PEAKsearch:MARGIN](#) on page 453

### Selecting a limit line

Selects one or more limit lines to evaluate for a peak search.

The table shows all limit lines available on the R&S ESW that are compatible to the current measurement configuration. You can activate the limit line by marking the corresponding checkbox and assigning the limit line to a trace.

For more information on designing, editing and managing limit lines in general, see [Chapter 9.5, "Display and Limit Lines"](#), on page 231.

For more information on the effects of a limit line on the peak search, see ["Defining peak characteristics \(or "When is a peak a peak?"\)"](#) on page 118.

Remote command:

See [Chapter 13.7.5.2, "Limit Lines"](#), on page 551.

### 7.3.4.2 Modifying a Peak List

**Access:** "Overview" > "Test Automation" > "Peak List"

The peak list contains the frequencies on which the peak search has identified peaks. It can be used as the basis of the final measurement.



#### Modifying a peak list (alternate way)

The R&S ESW also provides an alternate way to modify a peak list.

[More information.](#)

Trace/Detector	Frequency	Level	DeltaLimit	Comment
1 Max Peak	93.8400 MHz	84.21 dBµV		
1 Max Peak	118.2600 MHz	84.21 dBµV		
1 Max Peak	142.6800 MHz	84.21 dBµV		
1 Max Peak	167.1000 MHz	84.21 dBµV		
1 Max Peak	191.5200 MHz	84.21 dBµV		
1 Max Peak	215.9400 MHz	84.21 dBµV		
1 Max Peak	240.3600 MHz	84.21 dBµV		
1 Max Peak	264.7800 MHz	84.21 dBµV		
1 Max Peak	289.2000 MHz	84.21 dBµV		
1 Max Peak	313.6200 MHz	84.21 dBµV		
1 Max Peak	338.0400 MHz	84.21 dBµV		
1 Max Peak	362.4600 MHz	84.21 dBµV		

Figure 7-13: Overview of the peak list

### Reading the peak list

The table at the top of the dialog contains information when you measure with limit lines. Each cell of the table represents a trace and shows the limit lines that are assigned to that trace. In the screenshot above, for example, the limit line named "Another One" is active and assigned to Trace 1.



The main table shows the following information for each peak in the peak list. The size of the table depends on the number of peaks that have been found.

- **Trace / Detector**  
Shows the number of the trace and the detector used for that trace.
- **Frequency**  
Shows the frequency where the peak was found.
- **Level**  
Shows the absolute level value of the peak. The unit depends on the unit you have selected.
- **Delta Limit**  
Shows the distance of the peak to the nearest limit line that has been assigned to the corresponding trace. The distance is a value in dB. Available if you are using limit lines.
- **Comment**  
Allows you to add a comment to each peak as required (only possible after a peak search has been done).
-    
Deletes the corresponding row from the peak list.

The remote commands required to edit the peak list are described in [Chapter 13.5.7, "Peak Search"](#), on page 450 and [Chapter 13.5.8, "Peak List"](#), on page 455.

Editing a peak list.....	122
L Adding the current frequency to the peak list.....	123
Sorting the peak list.....	123
Exporting a peak list.....	123
Displaying peaks as symbols.....	123

### Editing a peak list

The R&S ESW allows you to edit a peak list that has been created, or even create a peak list that is not based on an automatic peak search.

- Adding a new frequency  
To add a new peak to the peak list, enter a **frequency** in the corresponding field and add it to the list with the "Insert" button.  
**Tip:** Alternatively, you can add the current receiver frequency including the measured level with the [Add to Peak List](#) softkey.  
The new frequency is added to the list regardless if the level threshold conditions have been fulfilled for that frequency.  
Note that the frequency has to be in the displayed frequency range.
- Deleting a frequency  
To remove a peak from the peak list, select the corresponding peak list row and delete it with the "Delete Peak Entry" button.  
Alternatively, use the  button in the peak list itself.  
You can also delete the complete peak list with the "Clear All Entries" button.

Remote command:

Add frequency: `CALCulate<n>:PEAKsearch:ADD` on page 451

Clear list: `CALCulate<n>:PEAKsearch:CLear[:IMMediate]` on page 452

**Adding the current frequency to the peak list ← Editing a peak list**

The receiver application allows you to add the current receiver frequency manually to the peak list.

To add the current receiver frequency to the peak list, proceed as follows:

- Use the "Add to Peak List" softkey available in the "Meas Config" or the "Marker Function" softkey menu.
- Use the "Add to Peak List" button available in the "Peak List" result display.

Remote command:

[CALCulate<n>:PEAKsearch:ADD](#) on page 451

**Sorting the peak list**

By default, the R&S ESW sorts the peaks by their "Frequency" in ascending order.

Alternatively, you can sort the peak list by the distance of a peak to the limit line (→ "Delta Limit"). This is also done in ascending order.

Sorting by the delta limit is available when a limit line is active and evaluated.

Remote command:

not supported

**Exporting a peak list**

The peak list can be exported to a file with the "Peak List Export" button.

This button opens a dialog box to export and save the contents of the peak list in ASCII format to a .dat file.

The file consists of a header and the results of the scan or the final measurement.

- The header is a list of general instrument settings and characteristics. It consists of three columns, each column separated by a semicolon: <parameter>;<value>;<unit>.
- The results are split into several data sections, one for each active trace. The data section begins with the entry `Trace <x> [Final] :`, followed by the trace characteristics and the peak list data itself.

For more information on exporting data, see [Chapter 9.3.8.1, "Reference: ASCII File Export Format"](#), on page 216.

By default, decimal places are separated by a point in the exported list. If necessary, you can use a comma instead of a point as the decimal separator.

Remote command:

Peak list of the scan: [MMEMory:STORe:PLIST](#) on page 455

Peak list of the final measurement: [MMEMory:STORe:FINAl](#) on page 455

Decimal separator: [FORMat:DEXPort:DSEParator](#) on page 569

**Displaying peaks as symbols**

Turns the labels on the peak position in the diagram on and off.

The peak labels have a different color and shape depending on the trace they are on. Trace 1, for example, has red crosses as the peak label. By default they are on.

Remote command:

[DISPlay\[:WINDow<n>\]:TRACe<t>:SYMBol](#) on page 454

### 7.3.4.3 Modifying a Peak List (Alternate Method)

**Access:**  > "Peak List"

In addition to the method described in [Chapter 7.3.4.2, "Modifying a Peak List"](#), on page 121, the Receiver application provides another approach to modify and edit a peak list.



Trace	Detector	Frequency	Level	ΔLimit
1	Max Peak	2.4 MHz	84.21 dBμV	---
1	Max Peak	6.9 MHz	84.21 dBμV	---
1	Max Peak	11.4 MHz	84.21 dBμV	---
1	Max Peak	15.9 MHz	84.21 dBμV	---
1	Max Peak	20.4 MHz	84.21 dBμV	---
1	Max Peak	24.9 MHz	84.21 dBμV	---
1	Max Peak	29.4 MHz	84.21 dBμV	---

Buttons: Peak Search, Add to Peak List, Symbols: On, Sort by Freq, Export Separator: .

#### Reading the peak list

The peak list result display basically contains the same information as the "Peak List" dialog box.

#### More information

Note that the "Comment" column is read-only in the peak list result display. If you would like to add a comment to a peak, you have to do it in the "Peak List" dialog box.

#### Modifying the contents of the peak list

When the result display is active, you can modify the peak list directly from within the result display with the corresponding buttons.

- **Peak Search**  
Performs a single peak search based on the current scan data.
- **Add to Peak List**  
→ ["Adding the current frequency to the peak list"](#) on page 123
- **Symbols**  
→ ["Displaying peaks as symbols"](#) on page 123
- **Sort by Freq and Sort by Delta**  
→ ["Sorting the peak list"](#) on page 123
- **Export and Separator**  
→ ["Exporting a peak list"](#) on page 123

## 7.3.5 Performing Final Measurements

During the final measurement, the R&S ESW does a measurement on each frequency in the peak list. When done, it updates the preliminary results in the peak list with those found during the final measurement. To avoid several tests with different detectors, you can use several detectors at the same time during the final measurement.

In case you are using a scan table in the test sequence, the final measurement is based on the contents of the scan table. When the scan table has been [turned off](#), the final measurement is based on the current bargraph configuration.

### Automatic vs interactive final measurements

The R&S ESW provides two methods to run a final measurement: an automatic final measurement and an interactive one.

An automatic final measurement measures all frequencies in the peak list automatically with limited means of interaction. During an automatic measurement, you can still interrupt ("Hold Final Meas") and resume the measurement or abort it completely ("Stop Final Meas"). But you will not be able to change the measurement configuration. The advantage is that you can let the measurement run on its own and do not have to operate the R&S ESW.

If you want to be able to control the final measurement, for example to change the configuration during the measurement, the R&S ESW also provides an interactive final measurement (which you can select even after you have started an automatic final measurement).

When you use the interactive final measurement, the R&S ESW interrupts the measurement before it measures a frequency part of the peak list. In this way, you can customize the measurement configuration for each frequency.



### Availability of measurement parameters

When you interrupt the scan or the final measurement, you can change only parameters that have an immediate effect on the measurement. All other parameters (e.g. trigger settings) are unavailable.

### Sequence for an interactive measurement

If you select the interactive final measurement, the R&S ESW initiates the following sequence.

1. The R&S ESW tunes to the first frequency in the peak list. The measurement configuration is as defined previously.
2. The R&S ESW positions a marker on that frequency and interrupts the measurement.
3. While the measurement is interrupted, you can change any setting that is available.

In addition, you have several options on how to proceed.

- Skip the current frequency.  
Positions the marker on the next frequency in the peak list without performing a final measurement on the current frequency.
  - Get max hold result for the current frequency.  
Writes the highest level that was measured for that frequency during the scan to the final peak list without performing a final measurement.
  - Stop the final measurement.
  - Perform a measurement on the current frequency.
4. When the final measurement for the current frequency is done, the R&S ESW replaces the scan result in the peak list with the result of the final measurement. If

the frequency has drifted compared to the one of the scan, it also updates the frequency in the peak list.

5. The R&S ESW continues with the next frequency in the peak list, positions the marker on that frequency etc.
6. When all frequencies in the peak list are finished, the R&S ESW opens the "Final Peak List", a table that contains the results for the final measurement.



Note that it is possible to start with an automatic measurement and later change into interactive mode. Likewise, it is possible to start measuring in interactive mode and later change into automatic mode.

- [Configuring Traces](#) ..... 126
- [Working with the Final Measurement Results](#)..... 128

### 7.3.5.1 Configuring Traces

**Access:** "Overview" > "Test Automation" > "Trace / Final Meas"

Note that the dialog box to configure traces contains the same functions as the dialog box to configure the final measurement, but with a slightly different layout.

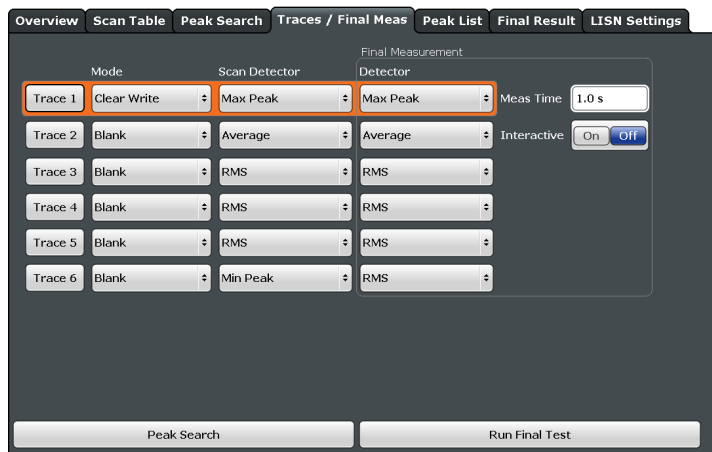

**Figure 7-14: Overview of the Final Meas configuration**

The remote commands required to configure the final measurement are described in [Chapter 13.5.9, "Final Measurement \(and Trace\) Configuration"](#), on page 460.

Functions in the "Trace / Final Meas" dialog box described elsewhere:

- ["Measurement Time"](#) on page 95

<a href="#">Trace Mode</a> .....	126
<a href="#">Detector</a> .....	127
<a href="#">Interactive</a> .....	128

#### Trace Mode

Defines the update mode for subsequent traces.

For more information, see [Chapter 9.3.1.2, "Analyzing Several Traces - Trace Mode"](#), on page 195.

"Clear Write"	Displays the level that has been measured last at each trace point. The old trace is overwritten.
"Max Hold"	Displays and saves the highest level that has been measured over several measurements at each trace point.
"Min Hold"	Displays and saves the lowest level that has been measured over several measurements at each trace point.
"Average"	Displays and saves the average level that has been determined over several measurements at each trace point. The number of measurements depends on the <a href="#">Scan Count</a> .
"View"	Freezes the contents of the trace memory and displays the corresponding trace. The trace is not updated when you start another measurement.
"Blank"	Removes the trace from the diagram.
"Transducer"	Draws a trace that shows the correction values of all active transducer factors in the currently selected frequency range. In case transducer factors overlap each other, the correction values are aggregated. Available for Trace 1 and in the receiver application only. <b>Note:</b> When you select the "Transducer" trace, the application temporarily removes all other traces from the diagram. You can restore the scan traces by selecting the original trace mode of trace 1 again.

Remote command:

[DISPlay\[:WINDow<n>\]:TRACe<t>:MODE](#) on page 462

View transducer: [\[SENSe:\]CORRection:TRANsducer:VIEW](#) on page 460

### Detector

Selects the trace detector.

**Note:** In the receiver application, you can apply different detectors to the bargraph, the scan and the final measurement.

"Max Peak"	Selects the <a href="#">Max or Positive Peak</a> detector.
"Min Peak"	Selects the <a href="#">Max or Positive Peak</a> detector.
"RMS"	Selects the <a href="#">RMS</a> detector.
"Average"	Selects the <a href="#">Average</a> detector.
"Quasipeak"	Selects the <a href="#">Quasipeak</a> detector.
"CISPR Average"	Selects the <a href="#">CISPR Average</a> detector.
"RMS Average"	Selects the <a href="#">RMS Average</a> detector.
"None"	Ignores the corresponding trace during the final measurement. Available for the final measurement.

Remote command:

Bargraph: `[SENSe:] DETector<t>:RECeiver[:FUNCTION]` on page 439

Scan: `[SENSe:] DETector<t>[:FUNCTION]` on page 442

Final measurement: `[SENSe:] DETector<t>:FMEasurement` on page 461

### Interactive

Turns interactive measurements on and off.

For more information, see "[Automatic vs interactive final measurements](#)" on page 125.

Remote command:

`[SENSe:] FMEasurement:AUTO` on page 462

### 7.3.5.2 Working with the Final Measurement Results

**Access:** "Overview" > "Test Automation" > "Final Result"

When the final measurement is done, the R&S ESW writes the results into a table that looks and feels similar to the peak list. Editing entries is, however, not possible.

The list contains all frequencies that have been measured during the final measurement.

Trace/Detector	Frequency	Level	DeltaLimit	Comment
1 Quasi Peak	93.8400 MHz	53.99 dBµV		
1 Quasi Peak	118.2600 MHz	53.99 dBµV		
1 Quasi Peak	142.6800 MHz	53.99 dBµV		
1 Quasi Peak	167.1000 MHz	53.99 dBµV		
1 Quasi Peak	191.5200 MHz	53.99 dBµV		
1 Quasi Peak	215.9400 MHz	53.99 dBµV		
1 Quasi Peak	240.3600 MHz	53.99 dBµV		
1 Quasi Peak	264.7800 MHz	53.99 dBµV		
1 Quasi Peak	289.2000 MHz	53.99 dBµV		
1 Quasi Peak	313.6200 MHz	53.99 dBµV		
1 Quasi Peak	338.0400 MHz	53.99 dBµV		
1 Quasi Peak	362.4600 MHz	53.99 dBµV		

**Figure 7-15: Overview of the "Final Results" table**

The functionality and information provided by the final results dialog box is similar to that provided by the peak list.

Functions to manage final results described elsewhere:

- "[Sorting the peak list](#)" on page 123
- "[Exporting a peak list](#)" on page 123
- "[Displaying peaks as symbols](#)" on page 123



### Alternate way to modify the final results

Like the peak list, you can also modify the final results directly via the "Final Meas" result display.

[More information.](#)

- ▶ Select the "SmartGrid" icon (☰) and start the "Final Meas" result display.

The remote commands required to manage final results are described in [Chapter 13.5.9, "Final Measurement \(and Trace\) Configuration"](#), on page 460 and [Chapter 13.5.10, "Final Results"](#), on page 464.

### Reading the peak list

The table at the top of the dialog contains information when you measure with limit lines. Each cell of the table represents a trace and shows the limit lines that are assigned to that trace.

The main table shows the following information for each frequency that has been measured. The size of the table depends on the number of peaks that have been found.

- **Rows with no highlighting**  
Limit check for the corresponding frequency has passed.
- **Rows in red highlighting**  
Limit check for the corresponding frequency has failed. This indicates a potential interferer.
- **Rows in blue highlighting**  
Indicates the currently selected row.
- **Trace / Detector**  
Shows the number of the trace and the detector used for that trace.
- **Frequency**  
Shows the frequency where the peak was found.
- **Level**  
Shows the absolute level value of the peak. The unit depends on the unit you have selected.  
The result also contains information about the phase that was measured when you are working with a LISN (L1, L2, L3, N).
- **Delta Limit**  
Shows the distance of the peak to the nearest limit line that has been assigned to the corresponding trace. The distance is a value in dB. Available if you are using limit lines.
- **Comment**  
Allows you to add a comment to each result as required.

## 7.3.6 Configuring Line Impedance Stabilization Networks (LISN)

**Access:** "Overview" > "Test Automation" > "LISN"

The R&S ESW supports several LISN models and provides functionality to control these devices.



For more information about using a LISN, see [Chapter 7.3.1.3, "Line Impedance Stabilization Network \(LISN\) Control"](#), on page 100.

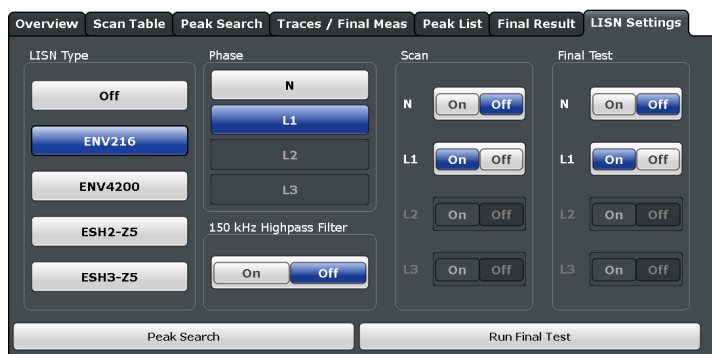

Figure 7-16: Overview of the "LISN" configuration

Note: the "Scan" and "Final Test" blocks are available in the Receiver application.

The remote commands required to configure the LISN are described in [Chapter 13.5.11, "LISN Configuration"](#), on page 468.

LISN Type..... 130  
 Phase..... 130  
 High-Pass Filter 150 kHz..... 131

**LISN Type**

Selects the LISN used for the measurement.

The following LISNs are supported by the R&S ESW:

- R&S ENV216
- R&S ENV432
- R&S ENV4200
- R&S ESH2-Z5
- R&S ESH3-Z5

Select "Off" when you are performing measurements without a LISN.

**More information**

Remote command:

`INPut<ip>:LISN[:TYPE]` on page 470

**Phase**

Selects the LISN phase to be measured.

Phases L2 and L3 are available when you are using the R&S ENV4200, R&S 432 or R&S ESH2-Z5 (four-line networks).

In the spectrum application, the I/Q analyzer and the analog demodulator, you can measure on one phase at a time (N, L1, L2 **or** L3).

In the receiver application, phase selection works as follows.

- You can measure more than one phase in a single measurement (N, L1, L2 **and** / **or** L3).

Instead of selecting the phase in the "Phase" column of the dialog, select the phases you want to measure in the "Scan" or the "Final Test" column ("On" considers the phase in the measurement, "Off" ignores the phase in the measurement). If you are measuring more than one phase, the R&S ESW performs a measurement for each of the selected phases.

- You can select different phase (combinations) for the scan and the final measurement.

The selection in the "Scan" and "Final Test" blocks of the dialog box override the selection in the "Phase" block of the dialog.

**Example:**

- Phase L1 is selected in the "Phase" block.
- Phase L1 and N are selected in the "Scan" block.
- Phase L1 is off in the "Final Test" block, but phase N is on.

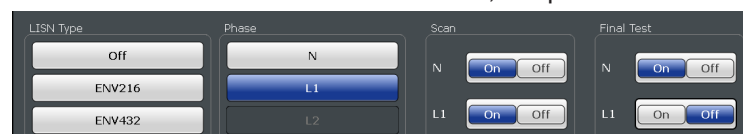

- During the scan, the R&S ESW measures both selected phases.
- During the final measurement, the R&S ESW measures phase N, but not phase L1.
- The phase selected in the "Phase" block is ignored for both the scan and the final measurement.

When scan and final measurement are done, the general phase (here: L1) becomes the selected phase again.

[More information](#)

Remote command:

`INPut<ip>:LISN:PHASe` on page 469

Scan: `[SENSe:]SCAN<sr>:LISN:PHASe` on page 468

Final measurement: `[SENSe:]FMEasurement:LISN:PHASe` on page 468

**High-Pass Filter 150 kHz**

Turns the high-pass filter on the LISN on and off.

The filter protects the receiver input from high signal levels below 150 kHz.

Available for measurements with R&S ENV216.

[More information](#)

Remote command:

`INPut<ip>:LISN:FILTER:HPASs[:STATe]` on page 469

## 7.4 CISPR APD Measurements

**Access:** [MODE] > "CISPR APD"

The Amplitude Probability Distribution (APD) is a statistical measurement that shows the "cumulative distribution of the probability of time that the amplitude of disturbance exceeds a specified level" (CISPR 16-1-1, Amendment 1:2005). So, basically, the mea-

surement determines the likelihood that a disturbance is above a specified level at a particular frequency (the measurement is usually performed on a fixed frequency).

The amplitude of the disturbance is expressed in terms of the corresponding field strength or voltage at the receiver input.

The APD is measured at the output of the envelope detector. Therefore, the APD yields the probability information over the entire disturbance envelope within the measurement bandwidth and a particular period of time.

The APD function has the following advantages.

- It provides an alternative way to present peak and average measurements (for example for microwave ovens in accordance with CISPR 11).
- It is able to calculate true average values.
- It shows high sensitivity and allows you to measure, for example, a single impulse.
- It allows you to measure unsteady levels.



#### APD vs CISPR APD

Note that the R&S ESW also provides an APD measurement for general purposes in the spectrum application.

This general APD function does not comply with CISPR 16-1-1 in various aspects and cannot be used for CISPR APD measurements.

Remote command:

`CALCulate:STATistics:CAPD[:STATe]` on page 422

The result display is made up out of a diagram and a table.

- The diagram contains a graphical representation of the measurement results (the probability with which a particular amplitude occurs).  
The x-axis represents the amplitude, the y-axis the (cumulative) probability.
- The table ("Result Summary") contains the number of samples used in the calculation and, for each trace, the following values:
  - Average amplitude
  - Peak amplitude

#### Configuring CISPR APD measurements

Most of the settings available in the CISPR APD application are similar to settings already available in the receiver application or the spectrum application.

All parameters specific to the CISPR APD application are described below.

- Frequency and span settings: are similar to those in the spectrum application. Refer to the documentation of the spectrum application for a detailed description of these parameters (including remote commands).
- Amplitude settings: are similar to those in the spectrum application. Refer to the documentation of the spectrum application for a detailed description of these parameters (including remote commands).

- Scale settings: are similar to those of the APD measurement available in the spectrum application.  
Refer to the documentation of the spectrum application for a detailed description of these parameters (including remote commands).
- Preselector settings: are similar to those in the receiver application.  
Refer to [Chapter 8.4.2, "Configuring the Preselector"](#), on page 142 for a detailed description of these parameters (including remote commands).
- Auto settings: are similar to those in the spectrum application.  
Refer to the documentation of the spectrum application for a detailed description of these parameters (including remote commands).
- Bandwidth settings: are similar to those in the receiver application.
  - ["Measurement Bandwidth"](#) on page 96 (called "Analysis BW" in the CISPR APD application, but it is the same)
  - ["Measurement Time"](#) on page 95 (called "Acquisition Time" in the CISPR APD application, but it is the same)
- Sweep settings: are similar to those in the receiver application.
  - ["Measurement Time"](#) on page 95 (called "Acquisition Time" in the CISPR APD application, but it is the same)
  - ["Scan Count"](#) on page 108 (called "Sweep / Average Count" in the CISPR APD application, but is the same)
- Trace settings: are similar to those in the spectrum application.  
Refer to the documentation of the spectrum application for a detailed description of these parameters (including remote commands).
- Trigger settings: are similar to those in the spectrum application (gated measurements are not supported).  
Refer to the documentation of the spectrum application for a detailed description of these parameters (including remote commands).
- General measurement settings: are similar to those in the receiver application.
  - ["Measurement Bandwidth"](#) on page 96 (called "Analysis BW" in the CISPR APD application, but it is the same)
  - ["Measurement Time"](#) on page 95 (called "Acquisition Time" in the CISPR APD application, but it is the same)
  - ["Percent Marker"](#) on page 134
- Lines settings: are not available in the CISPR APD application.
- Input source settings are similar to those in the receiver application.  
See [Chapter 8.4.1, "Configuring the Input"](#), on page 141 for a detailed description of these parameters (including remote commands).
- External generator settings (optional): are similar to those available in the spectrum application.  
Refer to the documentation of the spectrum application for a detailed description of these parameters (including remote commands).
- Output settings: are similar to those available in the receiver application.
  - [Chapter 8.4.4, "Configuring Outputs \(IF / Video / Demodulation\)"](#), on page 156
  - [Chapter 8.4.5, "Configuring LISNs"](#), on page 160
  - [Chapter 8.4.6, "Configuring Additional Outputs"](#), on page 160

- Marker settings: are similar to those in the receiver application. See [Chapter 9.4, "Marker Usage"](#), on page 218 for a detailed description of these parameters (including remote commands).
- Marker functions: are not available in the CISPR APD application.

[Percent Marker](#)..... 134

#### **Percent Marker**

Defines a probability value. Thus, the power which is exceeded with a given probability can be determined very easily. If marker 1 is deactivated, it is switched on automatically.

Remote command:

`CALCulate<n>:MARKer<m>:Y:PERCent` on page 470

## 8 Common Measurement Settings

Basic measurement settings that are common to many measurement tasks, regardless of the application or operating mode, are described here. If you are performing a specific measurement task, or an application other than the receiver application, be sure to check the specific application or mode description for settings that may deviate from these common settings.

- [Using the Fast Access Knobs](#)..... 135
- [Using the Fast Access Panel](#)..... 137
- [Configuration Overview](#)..... 139
- [Data Input and Output](#)..... 141
- [Amplitude and Vertical Axis Configuration](#)..... 162
- [Frequency and Span Configuration](#)..... 168
- [Bandwidth and Filter Configuration](#)..... 174
- [Trigger Configuration](#)..... 175

### 8.1 Using the Fast Access Knobs

The R&S ESW features two small knobs on its front panel labeled "Knob 1" and "Knob 2".

These knobs are designed to provide fast access to a (predefined) set of settings that you are using regularly, and change these settings without using the user interface. Each knob can carry several different functions.

Basically, the knobs work like the rotary knob. When you have selected the "Attenuation" parameter, for example, turning the rotary knob changes the attenuation by a certain amount. The same is possible with the fast access knobs: when you assign the attenuation to one of the knobs, you can change the attenuation by turning the knobs. The difference is, that you do not have to select the attenuation parameter in the user interface first to change the attenuation, but simply turn the knob. In addition, you are able to see the result diagrams the whole time, without dialog boxes blocking the view. (When one knob carries more than one function, you have to first select the required function by pressing the fast access knobs a couple of times, but you still do not have to use the user interface to change settings.)

#### **Example: Steps necessary to change the attenuation without the fast access knobs**

1. Press the [AMPT] key.
2. Press the "Ampt Config" softkey.
3. Select the "Attenuation" parameter.
4. Turn the rotary knob or enter the attenuation manually to change the attenuation. When you want to change the attenuation again, you have to repeat that procedure. Plus, almost the whole time, the result displays are blocked by a dialog box.

5. (...)

**Example: Steps necessary to change the attenuation when you have assigned that parameter to the fast access knobs**

1. (If the knob carries more than one function:  
Press the fast access knob repeatedly until "Att" appears in the interface to configure knobs.)
2. Turn the fast access knob to increase or decrease the attenuation.  
When you want to change the attenuation again, simply turn the knob. Plus, you are able to see the results all the time.

**Note:** The parameter stepsize of the knobs is the same as if you were using the rotary knob.

When you are using the R&S ESW for the first time, each knob carries a predefined function. These predefined functions differ, depending on the application you are using. For example, in the receiver application, one knob changes the attenuation and the other changes the measurement bandwidth. However, you can substitute these predefined functions. So basically, the fast access knobs do not carry a specific function.

If you want to have access to other functions, you can configure the knobs to do things as you like and assign functions to them (more or less) arbitrarily.

**Assigning functions to the fast access knobs**

1. Tap one of the interfaces to configure knobs in the user interface (depending on the knob you would like to configure).



The R&S ESW opens a dialog box with three tabs. Two tabs allow you to configure each of the fast access knobs. The third tab allows you to configure the "Fast Access" display which works similar to the fast access knobs. (You can access the "Fast Access" display via the SmartGrid )

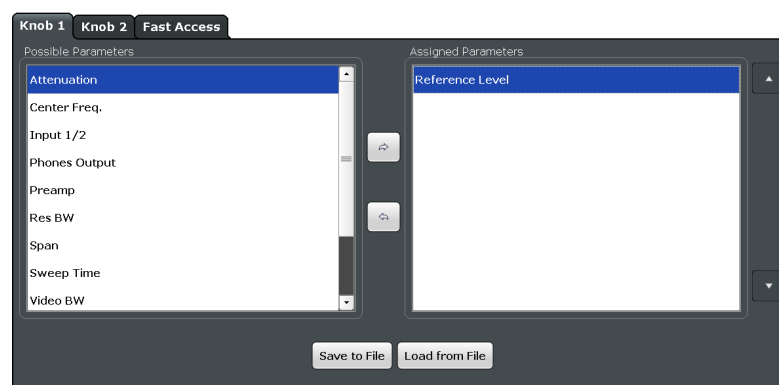

**Note:** The contents of the menus depend on the application you are running currently (spectrum, receiver, I/Q analyzer, analog demodulation or real-time).

- To assign an additional function to the knob, select one of the parameters in the left menu and move it to the right menu with the right arrow key (→). Alternatively, you can move items via drag & drop.

When you add a function to the knobs, the interface to configure knobs shows an additional dot.



**Tip:** The currently selected function is represented by a blue dot, the other functions by a white dot. In addition, the interface to configure knobs contains a label that describes the currently selected function (for example "Att" for attenuation).

- To remove a function from the knob, select one of the parameters in the right menu and move it to the left menu with the left arrow key (←).

Note that the labels "H-Line" and "V-Line" are abbreviations for "Horizontal Line" and "Vertical Line" and thus refer to display lines.

### Selecting a knob function

By default, the first function (blue dot) on the interface to configure knobs is the active one.

- Push the knob (it also serves as a button) repeatedly until you have reached the required function.
- Turn the knob to change the parameter value.

## 8.2 Using the Fast Access Panel

**Access:**  > "Fast Access"

The "Fast Access" panel is designed to provide fast access to a (predefined) set of settings that you are using regularly, and change these settings without accessing dialog boxes or softkey menus. The contents of the fast access panel are arbitrary.

When you add the fast access panel to the user interface, it shows the settings that you can control through the panel. Using the "Up" (▲) or "Down" (▼) feature changes the value of the corresponding setting. The stepsize is the same as if you were using the cursor keys on the front panel.



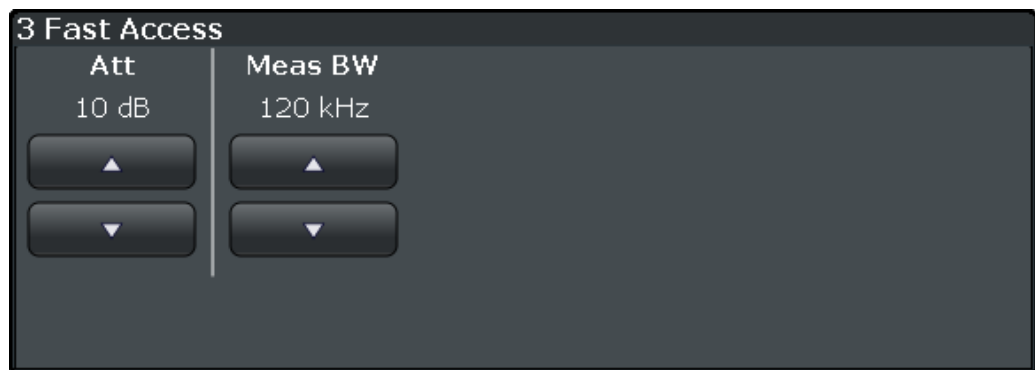

The advantage of the fast access panel is that it is easier and faster to change various settings in a single panel without having to find and access dialog boxes or softkey menus first. In addition, you can still view results while changing parameters, without dialog boxes blocking the view.

**Example: Steps necessary to change the attenuation without the fast access panel**

1. Press the [AMPT] key.
2. Press the "Ampt Config" softkey.
3. Select the "Attenuation" parameter.
4. Turn the rotary knob or enter the attenuation manually to change the attenuation. When you want to change the attenuation again, you have to repeat that procedure. Plus, almost the whole time, the result displays are blocked by a dialog box.
5. (...)

**Example: Steps necessary to change the attenuation when you have assigned that parameter to the fast access panel**

1. Add the fast access panel to the user interface.
2. Use the cursor keys in the panel to increase or decrease the attenuation. When you want to change the attenuation again, simply hit the "Up" or "Down" key. Plus, you are able to see the results all the time.

**Note:** The parameter stepsize of the knobs is the same as if you were using the cursor keys.

The fast access panel carries a few predefined settings. However, you can substitute the predefined settings, or add a few more, and thus define the contents of the fast access panel as you like.

**Assigning functions to the fast access panel**

1. Tap one of the interfaces to configure knobs in the user interface.



The R&S ESW opens a dialog box with several tabs. One tab each to configure the fast access knobs, one to configure the fast access display, and tabs to configure multimedia controllers.

You can access the fast access display via the SmartGrid .

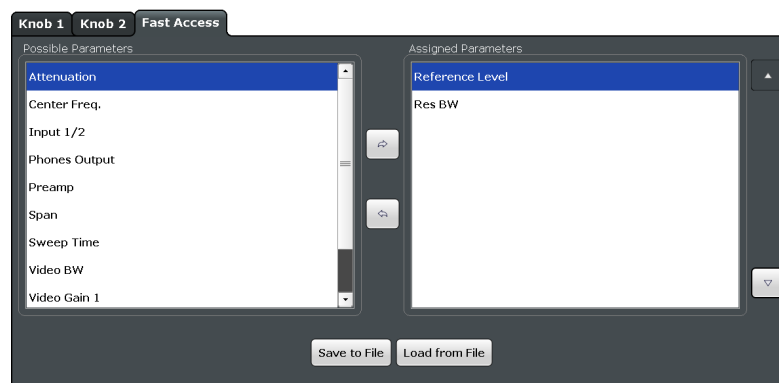

**Note:** The contents of the menus depend on the application you are running currently (spectrum, receiver, I/Q analyzer, analog demodulation or real-time).

- To assign an additional function to the panel, select one of the parameters in the left menu and move it to the right menu with the right arrow key (). Alternatively, you can move items via drag & drop.

When you add a function to the knobs, the setting is added to the fast access panel.



- To remove a function from the panel, select one of the parameters in the right menu and move it to the left menu with the left arrow key ().

## 8.3 Configuration Overview

Throughout the measurement channel configuration, an overview of the most important currently defined settings is provided in the configuration "Overview". The configuration overview is displayed when you select the "Overview" softkey, which is available at the bottom of all softkey menus.

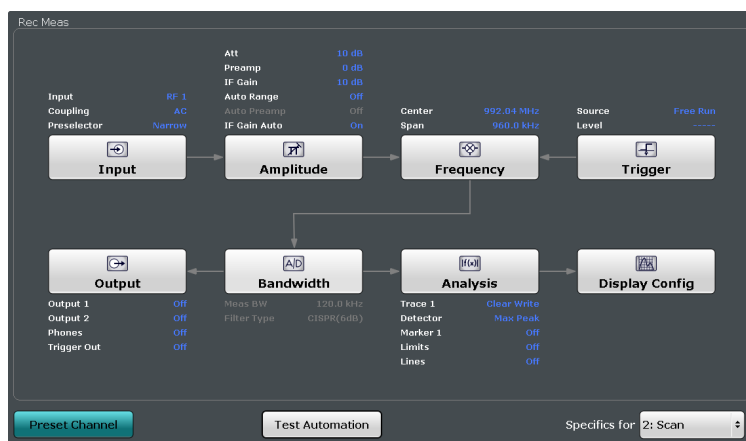

In addition to the main measurement settings, the configuration overview provides quick access to the main settings dialog boxes. Thus, you can easily configure an entire measurement channel from input over processing to output and analysis by stepping through the dialog boxes as indicated in the "Overview".

**To configure settings**

- ▶ Select any button to open the corresponding dialog box.
  - [Input](#)
  - [Amplitude](#)
  - [Frequency](#)
  - [Trigger](#)
  - [Output](#)
  - [Bandwidth](#)
  - [Analysis](#)
  - [Display Config](#)

(For more information about the "Test Automation" button, see [Chapter 7.3, "Test Automation"](#), on page 97.)

[Preset Channel](#)..... 140  
[Specifics for](#) ..... 141

**Preset Channel**

Select the "Preset Channel" button in the lower left-hand corner of the "Overview" to restore all measurement settings **in the current channel** to their default values.

Note that the [Preset] key restores the entire instrument to its default values and thus closes **all channels** on the R&S ESW (except for the default channel)!

See "[Preset Mode](#)" on page 327

Remote command:

[SYSTem:PRESet:CHANnel \[:EXEC\]](#) on page 582

**Specifics for**

The channel may contain several windows for different results. Thus, the settings indicated in the "Overview" and configured in the dialog boxes vary depending on the selected window.

Select an active window from the "Specifics for" selection list that is displayed in the "Overview" and in all window-specific configuration dialog boxes.

The "Overview" and dialog boxes are updated to indicate the settings for the selected window.

When you select the "Bargraph" item from the dropdown menu, changes are also applied to the scan. If settings are not available for the Bargraph (for example trace settings), changes only apply to the scan. The same goes for numerical result displays (for example the "Peak List").

## 8.4 Data Input and Output

The R&S ESW can analyze signals from different input sources and provide various types of output (such as video or trigger signals).

Functions to control in- and outputs described elsewhere:

- [Chapter 7.3.6, "Configuring Line Impedance Stabilization Networks \(LISN\)", on page 129](#)
- [Configuring the Input](#)..... 141
- [Configuring the Preselector](#)..... 142
- [External Generator](#)..... 144
- [Configuring Outputs \(IF / Video / Demodulation\)](#)..... 156
- [Configuring LISNs](#)..... 160
- [Configuring Additional Outputs](#)..... 160

### 8.4.1 Configuring the Input

**Access:** "Overview" > "Input" > "Input Source"

The default input source for the R&S ESW is "Radio Frequency", i.e. the signal at the [RF Input] connector on the front panel of the R&S ESW. In the Receiver application, this is the only available input source.

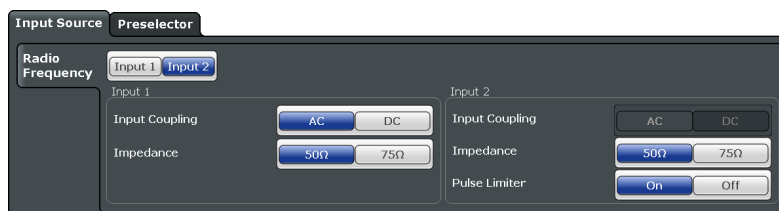

Functions in the "Input" dialog box described elsewhere:

- ["Input Selection"](#) on page 117

<a href="#">Input Coupling</a> .....	142
<a href="#">Impedance</a> .....	142
<a href="#">Pulse Limiter</a> .....	142

### Input Coupling

The RF input of the R&S ESW can be coupled by alternating current (AC) or direct current (DC).

Note that the "Input Coupling" feature is only available for input 2 when the [pulse limiter](#) is turned off. When the pulse limiter is on, the input is always DC coupled.

AC coupling blocks any DC voltage from the input signal. This is the default setting to prevent damage to the instrument. Very low frequencies in the input signal may be distorted.

However, some specifications require DC coupling. In this case, you must protect the instrument from damaging DC input voltages manually. For details, refer to the data sheet.

Remote command:

[INPut<ip>:COUPling](#) on page 473

### Impedance

For some measurements, the reference impedance for the measured levels of the R&S ESW can be set to 50  $\Omega$  or 75  $\Omega$ .

Select 75  $\Omega$  if the 50  $\Omega$  input impedance is transformed to a higher impedance using a 75  $\Omega$  adapter of the RAZ type. (That corresponds to 25 $\Omega$  in series to the input impedance of the instrument.) The correction value in this case is 1.76 dB = 10 log (75 $\Omega$ /50 $\Omega$ ).

This value also affects the unit conversion.

Remote command:

[INPut<ip>:IMPedance](#) on page 474

### Pulse Limiter

The pulse limiter, available for the second RF input, is a protection mechanism against high level pulses or signals (which can damage the input mixer).

When you turn on the pulse limiter, the attenuation is always at least 10 dB. Attenuation smaller than 10 dB is only available when you turn off the pulse limiter.

Remote command:

[INPut<ip>:ATTenuation:LIMiter\[:STATe\]](#) on page 475

## 8.4.2 Configuring the Preselector

**Access:** "Overview" > "Input" > "Preselector"

Preselector settings allow you to configure the signal path up to the input mixer, especially the preselector characteristics.

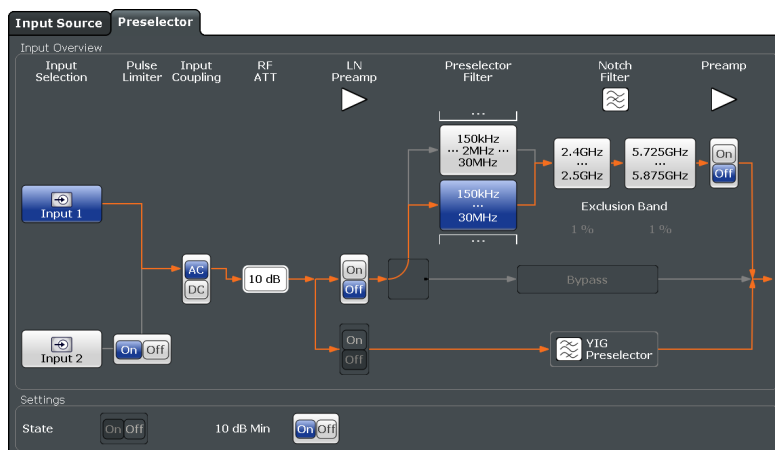

The orange arrow in the dialog box represents the current signal path. Grey arrows represent other possible signal paths.

Note that the signal path through the YIG preselector is always orange. This is because the YIG preselector is always used for measurements on frequencies greater than 8 GHz. A bypass of the YIG preselector is not possible.

(For measurements up to 8 GHz, you can use the optional preselector, see ["Preselector Filter Settings"](#) on page 143)

Functions of the "Preselector" dialog box described elsewhere:

- ["Input Selection"](#) on page 117
- ["Input Coupling"](#) on page 142
- ["Attenuation"](#) on page 116
- ["Preamplifier"](#) on page 116
- ["Pulse Limiter"](#) on page 142

<a href="#">Preselector State</a> .....	143
<a href="#">Preselector Filter Settings</a> .....	143

**Preselector State**

Turns the preselector on and off.

When you turn on the preselector, you can configure the characteristics of the preselector and add the preamplifier into the signal path.

For more information, see [Preselector Filter Settings](#).

When you turn off the preselector, the signal bypasses the preselector and the preamplifier, and is fed into the input mixer directly.

You can still use the optional low noise preamplifier, however.

Note that in the receiver application, the preselector is always turned on.

Remote command:

[INPut<ip>:PRESelection\[:STATE\]](#) on page 476

**Preselector Filter Settings**

Selects the filter of the preselector.

Most preselector filters are applied automatically during the measurement. However, you can control the following preselector filter characteristics. In addition, you can use several notch filters to suppress signals from the corresponding frequency range completely.

- 150 kHz to 30 MHz (**preselector filter**)  
Filters signals below 150 kHz and above 30 MHz.
- 150 kHz to 2 MHz to 30 MHz (**preselector filter**)  
Preselection in the frequency range from 150 kHz to 30 MHz is split into two stages.
  - During the first stage, the filter allows signals to pass from 150 kHz to 2 MHz.
  - During the second stage, another filter allows signals to pass from 2 MHz to 30 MHz.
- 2.4 GHz to 2.5 GHz (**notch filter**)  
Notch filter that excludes the frequency range from 2.4 GHz to 2.5 GHz.
- 5.725 GHz to 5.875 GHz (**notch filter**)  
Notch filter that excludes the frequency range from 5.725 GHz to 5.875 GHz.  
Note that when you apply one of the notch filters, measurement results for these frequency ranges are not displayed. The result is a gap in the trace in these ranges where markers do not work.  
On both sides of the filter, an additional "Exclusion Band" is added. The width of the exclusion band is 1 % of the lower and upper bandwidth of the notch filter (thus it has a different width on both sides of the filter). The edges of the exclusion band are indicated by two vertical lines in the diagram.

An orange arrow in the diagram represents the path you have selected.

For more information, see [Chapter 8.5.1.3, "Using the Preselector"](#), on page 165.

Remote command:

`INPut<ip>:PRESelection:FILTer:SPLit[:STATe]` on page 476

`INPut<ip>:PRESelection:FILTer:NOTCh<filter>[:STATe]` on page 475

### 8.4.3 External Generator

**Access:** "Overview" > "Input" > "External Generator"

The optional external generator control allows you to control the signal output of various signal generators, for example for bargraph measurements or stepped scans.

Note that the tracking generator settings have no effect for time domain scans.

- [Basics on External Generator Control](#)..... 144
- [External Generator Control Settings](#)..... 152

#### 8.4.3.1 Basics on External Generator Control

Some background knowledge on basic terms and principles used for external generator control is provided here for a better understanding of the required configuration settings.



External generator control is only available in the following applications.

- Receiver
- Spectrum Analyzer
- I/Q Analyzer
- Analog Demodulation

- [External Generator Connections](#)..... 145
- [Overview of Supported Generators](#)..... 147
- [Generator Setup Files](#)..... 149
- [Coupling the Frequencies](#)..... 149
- [Displayed Information and Errors](#)..... 151

**External Generator Connections**

The external generator is controlled either via a LAN connection or via the EXT. GEN. CONTROL GPIB interface of the R&S ESW supplied with the option.

**TTL synchronization**

In addition, TTL synchronization can be used with some Rohde & Schwarz generators connected via GPIB. The TTL interface is included in the AUX control connector of the External Generator Control option.



Using the TTL interface allows for considerably higher measurement rates than pure GPIB control, because the frequency stepping of the R&S ESW is directly coupled with the frequency stepping of the generator. For details see "[Coupling the Frequencies](#)" on page 149.

In [Figure 8-1](#) the TTL connection is illustrated using an R&S SMU generator, for example.

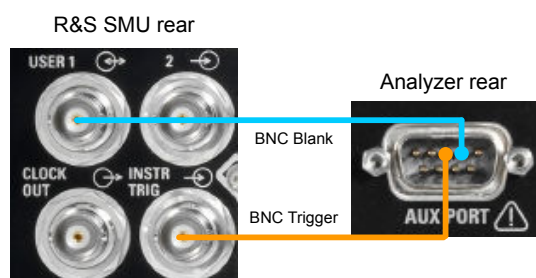

*Figure 8-1: TTL connection for an R&S SMU generator*

In [Figure 8-2](#), the connection for an R&S SMW is shown.



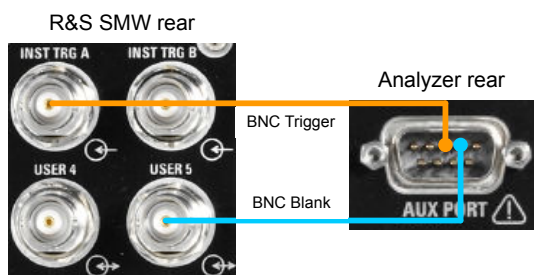

Figure 8-2: TTL connection for an R&S SMW generator

The external generator can be used to calibrate the data source by performing either transmission or reflection measurements.

**Transmission Measurement**

This measurement yields the transmission characteristics of a two-port network. The external generator is used as a signal source. It is connected to the input connector of the DUT. The input of the R&S ESW is fed from the output of the DUT. A calibration can be carried out to compensate for the effects of the test setup (e.g. frequency response of connecting cables).

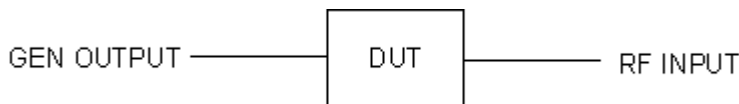

Figure 8-3: Test setup for transmission measurement

**Reflection Measurement**

Scalar reflection measurements can be carried out using a reflection-coefficient measurement bridge.

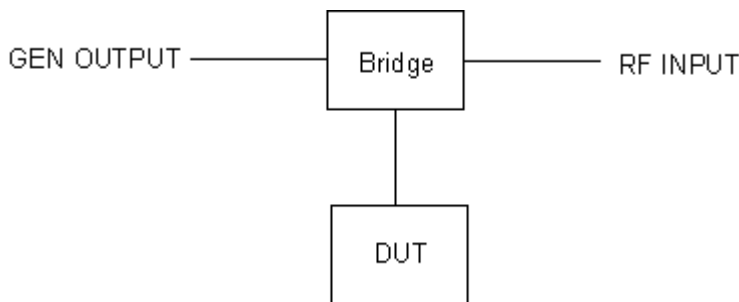

Figure 8-4: Test setup for reflection measurement

**Generated signal input**

In order to use the functions of the external generator, an appropriate generator must be connected and configured correctly. In particular, the generator output must be connected to the RF input of the R&S ESW.

### External reference frequency

In order to enhance measurement accuracy, a common reference frequency should be used for both the R&S ESW and the generator. If no independent 10 MHz reference frequency is available, it is recommended that you connect the reference output of the generator with the reference input of the R&S ESW and that you enable usage of the external reference on the R&S ESW via "SETUP" > "Reference" > "External Reference".

For more information on external references see [Chapter 11.4, "Reference Frequency Settings"](#), on page 320.

### Connection errors

If no external generator is connected, if the connection address is not correct, or the generator is not ready for operation, an error message is displayed (e.g. "Ext. Generator TCP/IP Handshake Error!", see ["Displayed Information and Errors"](#) on page 151).

### Overview of Supported Generators

Generator type	Model	Driver file	TTL support	Generator type	Model	Driver file	TTL support
SGS100A	6 GHz	SGS100A6	-	SMP	2 GHz	SMP02	X
	12 GHz	SGS100A12	-		3 GHz	SMP03	X
SGT100A	3 GHz	SGT100A3	-		4 GHz	SMP04	X
	6 GHz	SGT100A6	-		22 GHz	SMP22	X
SMA01A	3 GHz	SMA01A <sup>1)</sup>	X	SMR	20 GHz	SMR20	-
SMA100	3 GHz	SMA100A3	X		20 GHz	SMR20B11 <sup>3)</sup>	X
SMA100A	6 GHz	SMA100A6	X		27 GHz	SMR27	X
SMB100A	1 GHz	SMB100A1	X		27 GHz	SMR27B11 <sup>3)</sup>	X
	12 GHz	SMB100A12	X		30 GHz	SMR30	X
	2 GHz	SMB100A2	X		30 GHz	SMR30B11 <sup>3)</sup>	X
	20 GHz	SMB100A20	X		40 GHz	SMR40	X
	3 GHz	SMB100A3	X		40 GHz	SMR40B11 <sup>3)</sup>	X
	40 GHz	SMB100A40	X		50 GHz	SMR50	X
SMBV100A	3 GHz	SMBV100A3	X		50 GHz	SMR50B11 <sup>3)</sup>	X
	6 GHz	SMBV100A6	X		60 GHz	SMR60	X
SMC100A	1 GHz	SMC100A1	-		60 GHz	SMR60B11 <sup>3)</sup>	X

1) Requires firmware version V2.10.x or higher on the signal generator

2) Requires firmware version V1.10.x or higher on the signal generator

3) Requires the option SMR-B11 on the signal generator

4) Requires firmware version V3.20.200 or higher on the signal generator

Generator type	Model	Driver file	TTL support	Generator type	Model	Driver file	TTL support	
	3 GHz	SMC100A3	-	SMT	2 GHz	SMT02	-	
SME	2 GHz	SME02	X		3 GHz	SMT03	-	
	3 GHz	SME03	X		6 GHz	SMT06	-	
	6 GHz	SME06	X		SMU	2 GHz	SMU02	X
SMF100A	43.5 GHz	SMF100A	X	2 GHz		SMU02B31 <sup>2)</sup>	X	
SMF	22 GHz	SMF22	X	3 GHz		SMU03 <sup>2)</sup>	X	
	22 GHz	SMF22B2	X	3 GHz		SMU03B31 <sup>2)</sup>	X	
	43 GHz	SMF43	X	4 GHz		SMU04 <sup>2)</sup>	X	
	43 GHz	SMF43B2	X	4 GHz		SMU04B31 <sup>2)</sup>	X	
SMG	all	SMG	-	6 GHz		SMU06 <sup>2)</sup>	X	
SMGL	all	SMGL	-	6 GHz		SMU06B31 <sup>2)</sup>	X	
SMGU	all	SMGU	-	SMV		3 GHz	SMV03	-
SMH	all	SMH	-			SMW	3 GHz	SMW03
SMHU		SMHU	-	6 GHz	SMW06		X <sup>4)</sup>	
SMIQ	2 GHz	SMIQ02	X	20 GHz	SMW20		X <sup>4)</sup>	
	2 GHz	SMIQ02B	X	40 GHz	SMW40		X <sup>4)</sup>	
	2 GHz	SMIQ02E	-	SMX	all	SMX	-	
	3 GHz	SMIQ03	X		SMY	1 GHz	SMY01	-
	3 GHz	SMIQ03B	X	2 GHz		SMY02	-	
	3 GHz	SMIQ03E	-	HP8254A	40 GHz	HP8254A	-	
	4 GHz	SMIQ04B	X	HP8257D	70 GHz	HP8257D	-	
	6 GHz	SMIQ06B	X	HP8340A	26.5 GHz	HP8340A	-	
SMJ	3 GHz	SMJ03	X	HP8648	4 GHz	HP8648	-	
	6 GHz	SMJ06	X	HP ESG-A Series 1000A, 2000A, 3000A, 4000A	4 GHz	hp_esg	-	
SML	1 GHz	SML01	-	HP ESG B Series	3 GHz	hp_esg_b	-	
	2 GHz	SML02	-					
	3 GHz	SML03	-					

- 1) Requires firmware version V2.10.x or higher on the signal generator
- 2) Requires firmware version V1.10.x or higher on the signal generator
- 3) Requires the option SMR-B11 on the signal generator
- 4) Requires firmware version V3.20.200 or higher on the signal generator

### Generator Setup Files

For each signal generator type to be controlled by the R&S ESW a generator setup file must be configured and stored on the R&S ESW. The setup file defines the frequency and power ranges supported by the generator, as well as information required for communication. For the signal generators listed in ["Overview of Supported Generators"](#) on page 147, default setup files are provided. If necessary, these files can be edited or duplicated for varying measurement setups or other instruments.

The existing setup files can be displayed in an editor in read-only mode directly from the "External Generator" configuration dialog box. From there, they can be edited and stored under a different name, and are then available on the R&S ESW.

### Coupling the Frequencies

Frequency coupling means that the generator frequency and the frequency of the R&S ESW are the same.

- **Manual coupling:** a single frequency is defined
- **Automatic coupling:** a series of frequencies is defined (one for each sweep point), based on the current frequency at the RF input of the R&S ESW; the RF frequency range covers the currently defined span of the R&S ESW (unless limited by the range of the signal generator)

### Automatic coupling

If automatic coupling is used, the output frequency of the generator (source frequency) is calculated as follows:

$$F_{\text{Generator}} = \left| F_{\text{Analyzer}} * \frac{\text{Numerator}}{\text{Denominator}} + F_{\text{Offset}} \right|$$

*Equation 8-1: Output frequency of the generator*

Where:

$F_{\text{Generator}}$  = output frequency of the generator

$F_{\text{Analyzer}}$  = current frequency at the RF input of the R&S ESW

Numerator = multiplication factor for  $F_{\text{Analyzer}}$

Denominator = division factor for  $F_{\text{Analyzer}}$

$F_{\text{Offset}}$  = frequency offset for  $F_{\text{Analyzer}}$ , for example for frequency-converting measurements or harmonics measurements

The value range for the offset depends on the selected generator. The default setting is 0 Hz. Offsets other than 0 Hz are indicated by the "FRQ" label in the channel bar (see also ["Displayed Information and Errors"](#) on page 151).

### Swept frequency range

The  $F_{\text{Analyzer}}$  values for a swept measurement start with the start frequency and end with the stop frequency defined in the "Frequency" settings of the R&S ESW. The

resulting output frequencies ( [Result Frequency Start](#) and [Result Frequency Stop](#) ) are displayed in "External Generator" > "Measurement Configuration" for reference.

If the resulting frequency range exceeds the allowed ranges of the signal generator, an error message is displayed (see "[Displayed Information and Errors](#)" on page 151) and the [Result Frequency Start](#) and [Result Frequency Stop](#) values are corrected to comply with the range limits.

### TTL synchronization

Some Rohde & Schwarz signal generators support TTL synchronization when connected via GPIB. The TTL interface is included in the AUX control connector of the External Generator Control option.

When pure GPIB connections are used between the R&S ESW and the signal generator, the R&S ESW sets the generator frequency for each frequency point individually via GPIB, and only when the setting procedure is finished, the R&S ESW can measure the next sweep point.

For generators with a TTL interface, the R&S ESW sends a list of the frequencies to be set to the generator before the beginning of the first sweep. Then the R&S ESW starts the sweep and the next frequency point is selected by both the R&S ESW and the generator using the TTL handshake line "TRIGGER". The R&S ESW can only measure a value when the generator signals the end of the setting procedure via the "BLANK" signal.

Using the TTL interface allows for considerably higher measurement rates than pure GPIB control, because the frequency stepping of the R&S ESW is directly coupled with the frequency stepping of the generator.

### Reverse sweep

The frequency offset for automatic coupling can be used to sweep in the reverse direction. To do so, define a negative offset in the external generator measurement configuration. (Note that the frequency is defined as the unsigned value of the equation, thus a negative frequency is not possible.)

#### Example: Example for reverse sweep

$$F_{\text{AnalyzerStart}} = 100 \text{ MHz}$$

$$F_{\text{AnalyzerStop}} = 200 \text{ MHz}$$

$$F_{\text{Offset}} = -300 \text{ MHz}$$

$$\text{Numerator} = \text{Denominator} = 1$$

$$\rightarrow F_{\text{GeneratorStart}} = 200 \text{ MHz}$$

$$\rightarrow F_{\text{GeneratorStop}} = 100 \text{ MHz}$$

If the offset is adjusted so that the sweep of the generator crosses the minimum generator frequency, a message is displayed in the status bar ("Reverse Sweep via min. Ext. Generator Frequency!").

**Example: Example for reverse sweep via minimum frequency**

$$F_{\text{AnalyzerStart}} = 100 \text{ MHz}$$

$$F_{\text{AnalyzerStop}} = 200 \text{ MHz}$$

$$F_{\text{Offset}} = -150 \text{ MHz}$$

$$F_{\text{min}} = 20 \text{ MHz}$$

$$\text{Numerator} = \text{Denominator} = 1$$

$$\rightarrow F_{\text{GeneratorStart}} = 50 \text{ MHz}$$

$$\rightarrow F_{\text{GeneratorStop}} = 50 \text{ MHz via } F_{\text{min}}$$

**Displayed Information and Errors****Channel bar**

If external generator control is active, some additional information is displayed in the channel bar.

Label	Description
EXT TG: <source power>	External generator active; signal sent with <source power> level
LVL	Power Offset (see " <a href="#">Source Offset</a> " on page 155)
FRQ	Frequency Offset (see " <a href="#">(Automatic) Source Frequency (Numerator/Denominator/Offset)</a> " on page 155)

**Error and status messages**

The following status and error messages may occur during external generator control.

Message	Description
"Ext. Generator GPIB Handshake Error!" / "Ext. Generator TCPIP Handshake Error!" / "Ext. Generator TTL Handshake Error!"	Connection to the generator is not possible, e.g. due to a cable damage or loose connection or wrong address.
"Ext. Generator Limits Exceeded!"	The allowed frequency or power ranges for the generator were exceeded.
"Reverse Sweep via min. Ext. Generator Frequency!"	Reverse sweep is performed; frequencies are reduced to the minimum frequency, then increased again; see " <a href="#">Reverse sweep</a> " on page 150
"Ext. Generator File Syntax Error!"	Syntax error in the generator setup file (see " <a href="#">Generator Setup Files</a> " on page 149)
"Ext. Generator Command Error!"	Missing or wrong command in the generator setup file (see " <a href="#">Generator Setup Files</a> " on page 149)
"Ext. Generator Visa Error!"	Error with Visa driver provided with installation (very unlikely)

**NOTICE**

**Overloading**

At a reference level of -10 dBm and at an external generator output level of the same value, the R&S ESW operates without overrange reserve. That means the R&S ESW is in danger of being overloaded if a signal is applied whose amplitude is higher than the reference line. In this case, either the message "RF OVLD" for overload or "IF OVLD" for exceeded display range (clipping of the trace at the upper diagram border = overrange) is displayed in the status line.

Overloading can be avoided as follows:

- Reducing the output level of the external generator (" Source Power " on page 154 in "External Generator > Measurement Configuration")
- Increasing attenuation in the "Amplitude" menu ("Attenuation" on page 116).

**8.4.3.2 External Generator Control Settings**

**Access:** [INPUT/OUPUT] > "External Generator Config"

The "External Generator" settings are available if the R&S ESW External Generator Control option is installed. For each measurement channel, you can configure one external generator. To switch between different configurations, define multiple measurement channels.

For more information on external generator control, see [Chapter 8.4.3.1, "Basics on External Generator Control"](#), on page 144.

- [Interface Configuration Settings](#)..... 152
- [Measurement Settings](#)..... 154

**Interface Configuration Settings**

**Access:** "Overview" > "Input" > "External Generator" > "Interface Configuration"

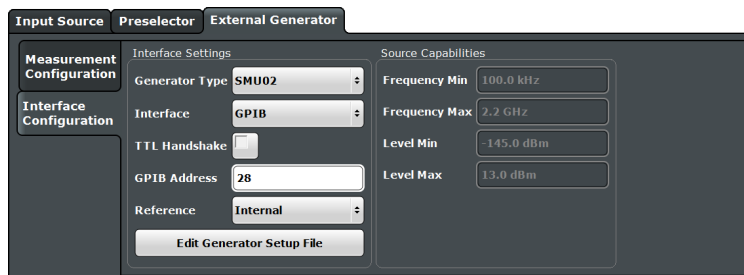

- [Generator Type](#) ..... 153
- [Interface](#) ..... 153
- [TTL Handshake](#) ..... 153
- [GPIB Address / TCPIP Address / Computer Name](#) ..... 153
- [Reference](#) ..... 153
- [Edit Generator Setup File](#) ..... 153
- [Frequency Min / Frequency Max](#) ..... 154
- [Level Min / Level Max](#) ..... 154

**Generator Type**

Selects the generator type and thus defines the generator setup file to use.

For an overview of supported generators, see "[Overview of Supported Generators](#)" on page 147. For information on generator setup files, see "[Generator Setup Files](#)" on page 149.

Remote command:

`SYSTem:COMMunicate:RDEvice:GENerator:TYPE` on page 481

**Interface**

Type of interface connection used. The following interfaces are currently supported:

- GPIB
- TCP/IP (not by all generators)

For details on which signal generators support which interfaces, see the documentation of the corresponding signal generator.

Remote command:

`SYSTem:COMMunicate:RDEvice:GENerator:INTerface` on page 480

**TTL Handshake**

If available for the specified generator type, this option activates TTL synchronization via handshake for GPIB connections.

Using the TTL interface allows for considerably higher measurement rates than pure GPIB control, because the frequency stepping of the R&S ESW is directly coupled with the frequency stepping of the generator.

For more information on TTL synchronization, see "[TTL synchronization](#)" on page 150.

For an overview of which generators support TTL synchronization see "[Overview of Supported Generators](#)" on page 147.

Remote command:

`SYSTem:COMMunicate:RDEvice:GENerator:LINK` on page 480

**GPIB Address / TCPIP Address / Computer Name**

For LAN connections: TCP/IP address of the signal generator

For GPIB connections: GPIB address of the signal generator.

Remote command:

`SYSTem:COMMunicate:GPIB:RDEvice:GENerator:ADDRess` on page 480

`SYSTem:COMMunicate:TCPIP:RDEvice:GENerator:ADDRess` on page 481

**Reference**

Selects the internal R&S ESW or an external frequency reference to synchronize the R&S ESW with the generator (default: internal).

Remote command:

`SOURce:EXTernal:ROSCillator[:SOURce]` on page 479

**Edit Generator Setup File**

Displays the setup file for the currently selected [Generator Type](#) in read-only mode in an editor.



Although the existing setup files are displayed in read-only mode in the editor, they can be saved under a different name (using "File > SaveAs").

Be careful, however, to adhere to the required syntax and commands. Errors are only detected and displayed when you try to use the new generator (see also "Displayed Information and Errors" on page 151).

For details, see "Generator Setup Files" on page 149.

**Frequency Min / Frequency Max**

For reference only: Lower and upper frequency limit for the generator.

**Level Min / Level Max**

For reference only: Lower and upper power limit for the generator.

**Measurement Settings**

**Access:** "Overview" > "Input" > "External Generator" > "Measurement Configuration"

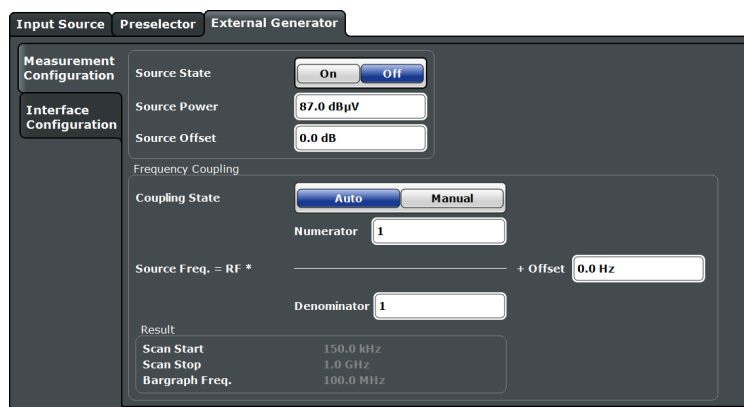

Source State ..... 154

Source Power ..... 154

Source Offset ..... 155

Source Frequency Coupling..... 155

(Manual) Source Frequency..... 155

(Automatic) Source Frequency (Numerator/Denominator/Offset)..... 155

Result Frequency Start ..... 156

Result Frequency Stop ..... 156

Bargraph Frequency..... 156

**Source State**

Activates or deactivates control of an external generator.

Remote command:

`SOURce:EXTernal[:STATe]` on page 479

**Source Power**

The output power of the external generator. The default output power is -20 dBm. The range is specified in the data sheet.

Remote command:

`SOURce:EXTernal:POWER[:LEVel]` on page 479

**Source Offset**

Constant level offset for the external generator. Values from -200 dB to +200 dB in 1 dB steps are allowed. The default setting is 0 dB. Offsets are indicated by the "LVL" label in the channel bar (see also ["Displayed Information and Errors"](#) on page 151).

Using this offset, attenuators or amplifiers at the output connector of the external generator can be taken into account. This is useful, for example, for the displayed output power values on screen or during data entry. Positive offsets apply to an amplifier, while negative offsets apply to an attenuator after the external generator.

Remote command:

`SOURce:POWer[:LEVel][:IMMediate]:OFFSet` on page 479

**Source Frequency Coupling**

Defines the frequency coupling mode between the R&S ESW and the generator.

For more information on coupling frequencies, see ["Coupling the Frequencies"](#) on page 149.

"Auto" Default setting: a series of frequencies is defined (one for each sweep point), based on the current frequency at the RF input of the R&S ESW (see ["\(Automatic\) Source Frequency \(Numerator/Denominator/Offset\)"](#) on page 155). The RF frequency range covers the currently defined span of the R&S ESW (unless limited by the range of the signal generator).

"Manual" The generator uses a single fixed frequency, defined by [\(Manual\) Source Frequency](#) which is displayed when you select "Manual" coupling.

Remote command:

`SOURce:EXTernal:FREQuency:COUPling[:STATe]` on page 477

**(Manual) Source Frequency**

Defines the fixed frequency to be used by the generator.

Remote command:

`SOURce:EXTernal:FREQuency` on page 477

**(Automatic) Source Frequency (Numerator/Denominator/Offset)**

With automatic frequency coupling, a series of frequencies is defined (one for each sweep point), based on the current frequency at the RF input of the R&S ESW.

However, the frequency used by the generator may differ from the input from the R&S ESW. The RF frequency can be multiplied by a specified factor, or a frequency offset can be added, or both.

**Note:** The input for the generator frequency is not validated, i.e. you can enter any values. However, if the allowed frequency ranges of the generator are exceeded, an error message is displayed on the R&S ESW. The values for [Result Frequency Start](#) and [Result Frequency Stop](#) are corrected to comply with the range limits.

The value range for the offset depends on the selected generator. The default setting is 0 Hz. Offsets  $\neq$  0 Hz are indicated by the "FRQ" label in the channel bar. Negative offsets can be used to define reverse sweeps.

For more information on coupling frequencies and reverse sweeps, see ["Coupling the Frequencies"](#) on page 149. For more information on error messages and the channel bar, see ["Displayed Information and Errors"](#) on page 151.

Remote command:

`SOURce:EXtErnal:FREquency[:FACTor]:DENominator` on page 477

`SOURce:EXtErnal:FREquency[:FACTor]:NUMerator` on page 478

`SOURce:EXtErnal:FREquency:OFFSet` on page 478

### Result Frequency Start

For reference only: The start frequency for the generator, calculated from the configured generator frequency and the start value defined for the R&S ESW.

### Result Frequency Stop

For reference only: The stop frequency for the generator, calculated from the configured generator frequency and the stop value defined for the R&S ESW.

### Bargraph Frequency

For reference only: The current receiver frequency that the R&S ESW is tuned to and that the bargraph evaluates (zero span frequency).

## 8.4.4 Configuring Outputs (IF / Video / Demodulation)

**Access:** "Overview" > "Output" > "Output Config"

The R&S ESW provides several outputs. The R&S ESW allows you to configure the output as required.

For details on the connectors refer to the R&S ESW Getting Started manual, chapter "Instrument Tour".

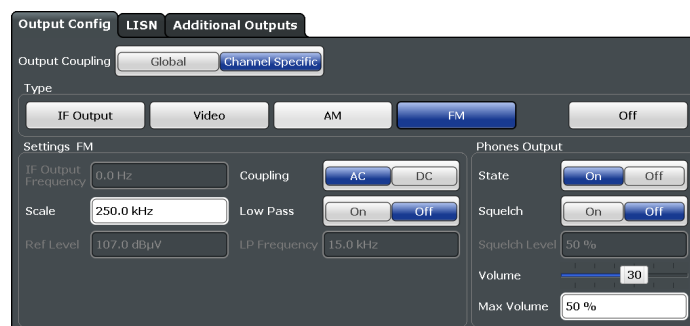

The remote commands required to configure the outputs are described in [Chapter 13.6.2.1, "IF / Video / Demodulation"](#), on page 483.

### Further information

For more information about LISN control refer to [Chapter 7.3.1.3, "Line Impedance Stabilization Network \(LISN\) Control"](#), on page 100.

For more information about the digital baseband output refer to the documentation of the I/Q Analyzer.

Output Coupling.....	157
Selecting the output type.....	157
L Configuring the output of the IF signal.....	157
L Configuring the output of the Video signal.....	158
L Configuring the output of an AM signal.....	158
L Configuring the output of an FM signal.....	158
Controlling and configuring the output.....	158
L IF Output Frequency.....	158
L Coupling.....	158
L Reference Level for Output.....	158
L Low Pass.....	158
L Phones.....	159
L Squelch.....	159
L Scale.....	159
Controlling the volume.....	159

### Output Coupling

Selects the scope of the output settings.

- |                    |   |
|--------------------|---|
| "Global"           | The output settings apply to all measurement channels / applications.   |
| "Channel Specific" | The output settings apply to the current measurement channel / application only. You can configure each channel separately. |

Remote command:

`OUTPut<i>:LINK` on page 486

### Selecting the output type

Selects the type of analog signal you want to output.

- |                 |  |
|-----------------|--|
| "IF Output"     | Outputs the IF signal (see " <a href="#">Configuring the output of the IF signal</a> " on page 157 for available settings).<br>(Unavailable for audio output.) |
| "Video"         | Outputs the video signal (see " <a href="#">Configuring the output of the Video signal</a> " on page 158 for available settings).                              |
| "AM"            | Outputs the AM demodulated signal (see " <a href="#">Configuring the output of an AM signal</a> " on page 158 for available settings).                         |
| "FM"            | Outputs the FM demodulated signal (see " <a href="#">Configuring the output of an FM signal</a> " on page 158 for available settings).                         |
| "Current Focus" | Outputs the data of the currently selected measurement window (highlighted with a blue frame).<br>Available in the analog demodulation application.            |
| "Off"           | Turns off the output.  |

Remote command:

`OUTPut<i>:IF[:SOURce]` on page 486

### Configuring the output of the IF signal ← Selecting the output type

For the output of the IF signal, you can adjust the following parameters.

- "[IF Output Frequency](#)" on page 158
- "[Reference Level for Output](#)" on page 158 (read only)

**Configuring the output of the Video signal ← Selecting the output type**

Additional settings for video signal output are not supported.

**Configuring the output of an AM signal ← Selecting the output type**

For the output of AM demodulated signals, you can adjust the following parameters.

- "Scale" on page 159
- "Low Pass" on page 158
- "Phones" on page 159

**Configuring the output of an FM signal ← Selecting the output type**

For the output of FM demodulated signals, you can adjust the following parameters.

- "Coupling" on page 158
- "Scale" on page 159
- "Low Pass" on page 158
- "Phones" on page 159

**Controlling and configuring the output**

Depending on the selected [output type](#), you can configure one or more of the following output characteristics.

**IF Output Frequency ← Controlling and configuring the output**

Defines the output frequency of the IF signal.

The range is:  $(RBW / 2)$  to  $(240 \text{ MHz} - (RBW / 2))$

Remote command:

[OUTPut<i>:IF:IFFrequency](#) on page 484

**Coupling ← Controlling and configuring the output**

Selects the type of current that is transferred at the output.

Available for linear signal output.

"AC Coupling" Rejects the DC component of the signal.  
This coupling protects the output from damage, but can distort very low frequencies.

"DC Coupling" Transfers the complete signal (DC and AC components).

Remote command:

[OUTPut<i>:IF:COUPling](#) on page 484

**Reference Level for Output ← Controlling and configuring the output**

Shows the reference level of the signal, if the level of the output signal depends on the reference level of the current measurement.

Remote command:

not supported

**Low Pass ← Controlling and configuring the output**

Turns a low pass filter to control the frequencies that are output on and off.

When you turn on the filter, you can define its **cutoff frequency**. The available cutoff frequencies depend on the type of output and the individual settings of the selected [output type](#).

Remote command:

[OUTPut<i>:IF:LPASs\[:STATe\]](#) on page 485

[OUTPut<i>:IF:LPASs:FREQuency:MANual](#) on page 484

### Phones ← Controlling and configuring the output

Turns additional output of the signal on the headphone jack on and off.

When you turn on this feature, you can listen to the signal with speakers or headphones. To control the volume of the output, use either the volume control knob on the front panel or the [volume slider](#) available in the "Phones" dialog box.

Remote command:

[OUTPut<i>:IF:AUDio](#) on page 483

### Squelch ← Controlling and configuring the output

You can suppress noise during audio output over the headphone jack for demodulated AM or FM signals with the "Squelch" feature.

When you turn on this feature, you can define a "Threshold" in %, below which the signal is not demodulated (and thus not audible). The squelch level is indicated by a red line in the diagram.

Remote command:

[\[SENSe:\]DEMod:SQUelch\[:STATe\]](#) on page 487

[\[SENSe:\]DEMod:SQUelch:LEVel](#) on page 487

### Scale ← Controlling and configuring the output

Defines the scale for the data you are transferring.

The unit depends on the signal type you are transferring.

- AM signals: a value in %.
- FM signals: a value in Hz

Remote command:

[OUTPut<i>:IF:SCALe](#) on page 485

### Controlling the volume

**CAUTION!** Risk of hearing damage. To protect your hearing, make sure that the volume setting is not too high before putting on the headphones.

When you output an audio signal and listen to it with headphones, for example, you can control the volume of the output.

One way to control the volume is to use the **volume control knob** on the front panel of the R&S ESW.



A similar functionality is available in the "Phones" tab of the "Output Config" dialog box. The **volume control slider** has the same effect as the volume control knob. For the slider, the volume is a percentage from 0 % to 100 % with 100 % being the loudest.



In addition to simply changing the volume, you can also define a **maximum volume level**. The maximum volume level limits the audio output to a certain level. The volume control knob and slider will not go further than this level.

Remote command:

Volume: `SYSTem:SPEaker:VOLume` on page 488

Maximum volume: `SYSTem:SPEaker:MAXVolume` on page 487

Mute: `SYSTem:SPEaker:MUTe` on page 488

### 8.4.5 Configuring LISNs

For more information see [Chapter 7.3.6, "Configuring Line Impedance Stabilization Networks \(LISN\)"](#), on page 129.

### 8.4.6 Configuring Additional Outputs

**Access:** "Overview" > "Output" > "Additional Outputs"

The R&S ESW provides additional outputs that you can use for various tasks.

The remote commands required to configure the outputs are described in [Chapter 13.6.2.2, "Additional Output"](#), on page 488.



Providing output for LISN control is described in [Chapter 7.3.1.3, "Line Impedance Stabilization Network \(LISN\) Control"](#), on page 100.

Probe Power Supply.....	160
Trigger 2/3.....	161
L Output Type .....	161
L Level .....	161
L Pulse Length .....	162
L Send Trigger .....	162

#### Probe Power Supply

Selects the probe connector that is supplied with power.

The probe power supply is a global setting - when you change it in one measurement channel, it is also changed in the others.

"Probe 1"           Supplies the 3-pin probe connector with power.

"Probe 2"           Supplies the 5-pin probe connector with power.

"Off"               Turns off the power supply for the probe connectors.

Remote command:

`OUTPut:PROBe<probe>[:POWer]` on page 488

### Trigger 2/3



Defines the usage of the variable Trigger Input/Output connectors, where:

- "Trigger 2" : Trigger Input/Output connector on the front panel
  - "Trigger 3" : Trigger 3 Input/Output connector on the rear panel
- (Trigger 1 is INPUT only.)

- "Input" The signal at the connector is used as an external trigger source by the R&S ESW. Trigger input parameters are available in the "Trigger" dialog box.
- "Output" The R&S ESW sends a trigger signal to the output connector to be used by connected devices. Further trigger parameters are available for the connector.

Remote command:

`OUTPut:TRIGger<port>:DIRection` on page 489

### Output Type ← Trigger 2/3

Type of signal to be sent to the output

- "Device Triggered" (Default) Sends a trigger when the R&S ESW triggers.
- "Trigger Armed" Sends a (high level) trigger when the R&S ESW is in "Ready for trigger" state. This state is indicated by a status bit in the `STATUS:OPERation` register (bit 5), as well as by a low-level signal at the AUX port (pin 9).
- "User Defined" Sends a trigger when you select the "Send Trigger" button. In this case, further parameters are available for the output signal.

Remote command:

`OUTPut:TRIGger<port>:OTYPe` on page 489

### Level ← Output Type ← Trigger 2/3

Defines whether a high (1) or low (0) constant signal is sent to the trigger output connector.

The trigger pulse level is always opposite to the constant signal level defined here. For example, for "Level = High", a constant high signal is output to the connector until you select the [Send Trigger](#) function. Then, a low pulse is provided.

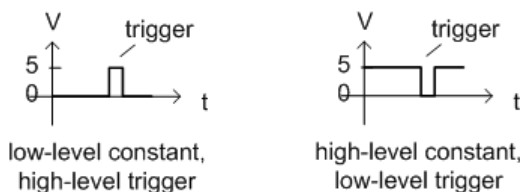



Remote command:

`OUTPut:TRIGger<port>:LEVel` on page 489

#### **Pulse Length ← Output Type ← Trigger 2/3**

Defines the duration of the pulse (pulse width) sent as a trigger to the output connector.

Remote command:

`OUTPut:TRIGger<port>:PULSe:LENGth` on page 490

#### **Send Trigger ← Output Type ← Trigger 2/3**

Sends a user-defined trigger to the output connector immediately.

Note that the trigger pulse level is always opposite to the constant signal level defined by the output `Level` setting. For example, for "Level" = "High", a constant high signal is output to the connector until you select the "Send Trigger" function. Then, a low pulse is sent.

Which pulse level will be sent is indicated by a graphic on the button.

Remote command:

`OUTPut:TRIGger<port>:PULSe:IMMediate` on page 490

## 8.5 Amplitude and Vertical Axis Configuration

In the Receiver application, measurement results usually consist of the measured signal levels (amplitudes) displayed on the vertical (y-)axis for the determined frequency spectrum or for the measurement time (horizontal, x-axis). The settings for the vertical axis, regarding amplitude and scaling, are described here.

- [Increasing Measurement Sensitivity \(or Avoiding an Input Mixer Overload\)](#).....162
- [Amplitude Settings](#)..... 165
- [Diagram Scale](#).....167
- [Preselector](#)..... 168

### 8.5.1 Increasing Measurement Sensitivity (or Avoiding an Input Mixer Overload)

Measurements often confront you with unknown or unintentional signals with unknown signal levels (and often with pulse characteristics). Such signals can either have very weak signal levels, in which case you might miss them during the measurement. Or they can have very strong signal levels, in which case they can damage the input mixer.

#### **NOTICE**

##### **Risk of damage to the input mixer**

Do not overload the input mixer.

Overloading the input mixer can damage it. The following topics contain advice on how to avoid an overload of the input mixer. Read them carefully before applying a signal.

### Protecting the input mixer

Protecting the input mixer from damage should always be considered first when setting up a measurement.

This is especially true for receiver measurements, which often measure unknown signals that contain pulses with possible strong signal levels.

The input mixer of the R&S ESW is equipped with an overload protection mechanism. If you apply a signal whose power exceeds the specified limit (see datasheet), the connection between the RF input and the input mixer is cut off. The R&S ESW displays a corresponding message in the status display.

Note that pulses have different level characteristics. Refer to the data sheet for more information on the allowed maximum pulse energy.

The signal level at the input mixer is calculated as follows.

Mixer Level = Input Level - attenuation + gain



### RF input protection

The R&S ESW is equipped with an overload protection mechanism. This mechanism becomes active as soon as the signal level at the input mixer exceeds the specified limit. It ensures that the connection between RF input and input mixer is cut off.

In this case, you must decrease the level at the RF input connector and then close the message box. Then measurements are possible again.

- [Using the RF Attenuator](#)..... 163
- [Using the Preamplifier](#)..... 164
- [Using the Preselector](#)..... 165

#### 8.5.1.1 Using the RF Attenuator

The first tool provided by the R&S ESW to control measurement sensitivity is the RF attenuator.

The RF attenuator is available in all hardware configurations of the R&S ESW.

Attenuation has the following effects on the measurement:

- High attenuation protects the input mixer: the main purpose of the attenuator is to protect the input mixer.
- High attenuation makes sure that the measurement results are reliable (signals that are stronger than allowed can distort the results)
- High attenuation helps you to avoid intermodulation
- High attenuation increases inherent noise (i.e. the noise floor) and thus decreases measurement sensitivity: if you increase attenuation by 10 dB, the sensitivity is reduced by 10 dB (in other words: the displayed noise increases by 10 dB)

Depending on the required test setup, a compromise must be found between a high sensitivity, low intermodulation and input mixer protection. This is best done by letting the R&S ESW determine the ideal attenuation automatically.

You can determine the attenuation automatically with the auto ranging feature in the receiver application and the auto attenuation feature in the other applications. Determining the attenuation automatically might not necessarily utilize the maximum dynamic range, but still yields valid and reliable results.

When you select the attenuation manually and are measuring unknown signals, especially DUTs with a high RFI voltage, always select the highest possible attenuation level before you apply the signal.

If you need a better sensitivity or signal-to-noise ratio, make sure that the applied signal does not exceed the specified limits, before you lower the attenuation.

For further protection of the input mixer, the R&S ESW does not allow you to select attenuation levels of less than 10 dB unless you explicitly turn on this feature ("[10 dB Minimum Attenuation](#)").

---

### NOTICE

#### Risk of damage to the input mixer

- Do not apply a 0 dB attenuation when you measure unknown signals or RFI voltage in combination with an artificial network (LISN). During phase switching, such test setups generate very strong pulses which can damage the input mixer.
- When you allow attenuation of less than 10 dB in combination with auto ranging, make sure that the signal level at the RF input does not exceed the allowed limits. Exceeding the limits can damage the input mixer.

---

#### 8.5.1.2 Using the Preamplifier

The second tool that allows you to control measurement sensitivity is the preamplifier.

In addition to the standard preamplifier available in every R&S ESW, an additional low noise amplifier is available as an optional component (R&S ESW-B24).

Signal gain has the following effects on the measurement:

- The preamplifier allows you to detect even weak signals.
- The preamplifier reduces the noise figure of the R&S ESW and thus increases its sensitivity. Thus, it is recommended to use the preamplifier for measurements that require maximum sensitivity.
- The preamplifier reduces the dynamic range. If a measurement should be performed at maximum dynamic range, you should turn off the preamplifier.
- The preamplifier is located after the preselection filters; this reduces the risk of overloading the input mixer by strong out-of-band signals.
- The optional low noise amplifier is located in front of the preselection filters which increases the measurement sensitivity.

The gain of the preamplifier is automatically considered in the level display. The disadvantage of a lower large-signal immunity (intermodulation) is reduced by the preselector.

### 8.5.1.3 Using the Preselector

The third tool that allows you to control measurement sensitivity is the preselector.

Preselection has the following effects on the measurement:

- Preselection rejects most of the spectral energy which helps to protect the input mixer and thus makes sure that the measurement results are valid and reliable.
- Preselection filters out signals that you do not want to be displayed (selectivity) and thus allows you to analyze only the frequency range you are interested in.

The preselector of the R&S ESW consists of several filters which are automatically applied during measurements. The filter that is used depends on the frequency that is currently measured. You can see the list of filters and the progress in the "Preselector" result display. The currently applied filter is indicated by a green LED, filters that are outside the scan range are ignored.



Figure 8-5: Preselector result display. The green LED indicates the currently applied filter.

In the frequency range from 150 kHz to 30 MHz, you can select whether to preselect in a single stage (150 kHz to 30 MHz), or split the preselection into two stages, each of which applies a separate filter: one from 150 kHz to 2 MHz, and another from 2 MHz to 30 MHz.

In addition, the R&S ESW provides several notch filters to suppress certain frequency ranges completely.



#### Using the preselector

Switching the filters is a mechanical process. Avoid excessive filters switches, because the hardware can wear out.

Note that results in a frequency band are only displayed if there is at least one valid measurement point in the corresponding range. If a particular measurement point is captured by more than one filter, the R&S ESW displays the combined results.



#### Notch filter

The R&S ESW provides additional notch filters that suppress signals in the frequency bands from 2.4 GHz to 2.5 GHz and 5.725 GHz to 5.875 GHz.

## 8.5.2 Amplitude Settings

**Access:** "Overview" > "Amplitude" > "Amplitude"

Amplitude settings determine how the R&S ESW processes or displays the input signals.

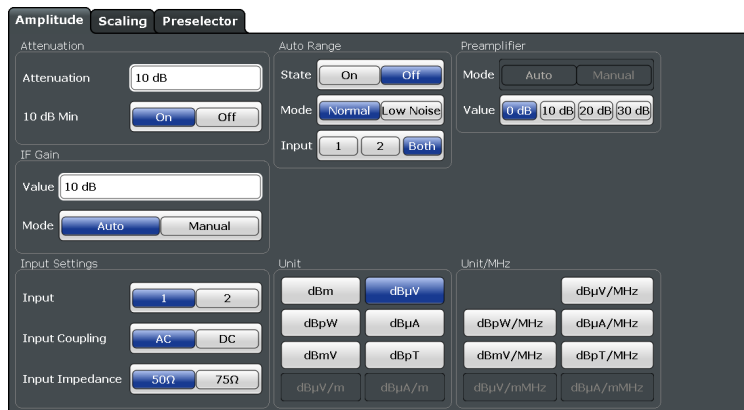

Functions in the "Amplitude" dialog box described elsewhere:

- "Attenuation" on page 116
- "Auto Range" on page 115
- "Preamplifier" on page 116
- "Input Selection" on page 117
- " Input Coupling " on page 142
- " Impedance " on page 142

10 dB Minimum Attenuation..... 166  
 Unit..... 166  
     ↳ dBx/MHz..... 167

**10 dB Minimum Attenuation**

Turns the availability of attenuation levels of less than 10 dB on and off.

When you turn on this feature, the attenuation is always at least 10 dB. This minimum attenuation protects the input mixer and avoids accidental setting of 0 dB, especially if you measure DUTs with high RFI voltage.

When you turn it off, you can also select attenuation levels of less than 10 dB.

The setting applies to a manual selection of the attenuation as well as the automatic selection of the attenuation.

**Notice:** For more information, see [Chapter 8.5.1, "Increasing Measurement Sensitivity \(or Avoiding an Input Mixer Overload\)"](#), on page 162.

Remote command:

`INPut<ip>:ATTenuation:PROTection[:STATe]` on page 495

**Unit**

Selects the unit displayed on the vertical axis.

The unit on the vertical axis represents the unit the results are evaluated in. You can select one of the following units: dBm, dBμV, dBpW, dBμA, dBmV, dBpT.

Remote command:

`CALCulate<n>:UNIT:POWer` on page 493

**dBx/MHz ← Unit**

Turns the display of results in units relative to a 1 MHz bandwidth on and off.

You can normalize the following units to 1 MHz.

Unit	Relative unit
dBµV	dBµV/MHz
dBµV/m	dBµV/mMHz (Available for active transducers only.)
dBmV	dBmV/MHz
dBµA	dBµA/MHz
dBµA/m	dBµA/mMHz (Available for active transducers only.)
dBpW	dBpW/MHz
dBpT	dBpT/MHz

The conversion to 1 MHz bandwidth is realized via the pulse bandwidth of the selected resolution bandwidth.

**Example:**

Conversion example for dBµV:

$$P[\text{dB}\mu\text{V}/\text{MHz}] = P[\text{dB}\mu\text{V}] - 20 \cdot \log\left(\frac{B_{\text{imp}}[\text{MHz}]}{1\text{MHz}}\right)$$

P = Displayed level

B<sub>imp</sub> = Pulse bandwidth of the selected RBW

If you are using another unit, replace "dBµV" with the corresponding unit.

The conversion is also possible when a transducer defines the used unit.

Remote command:

CALCulate<n>:UNIT:POWER on page 493

**8.5.3 Diagram Scale**

**Access:** "Overview" > "Amplitude" > "Scaling"

Scaling settings configure the vertical axis of diagrams.



[Grid Range / Minimum Level](#).....168

**Grid Range / Minimum Level**

Defines the scale of the vertical diagram axis.

The display ranges go from 10 dB to 200 dB in 10 dB steps. Invalid entries or combinations of range and minimum level are rounded off to the nearest valid value.

- **"Range"**  
Defines the level display range for the scan diagram.
- **"Minimum Level"**  
Defines the minimum level of the display range.

Remote command:

Range: `DISPlay[:WINDow<n>]:TRACe<t>:Y[:SCALe]` on page 497

Min. level: `DISPlay[:WINDow<n>]:TRACe<t>:Y[:SCALe]:BOTTom` on page 497

**8.5.4 Preselector**

For more information see [Chapter 8.4.2, "Configuring the Preselector"](#), on page 142.

**8.6 Frequency and Span Configuration**

The frequency and span settings define the scope of the signal and spectrum that you want to analyze.

- [Impact of the Frequency and Span Settings](#)..... 168
- [Frequency and Span Settings](#)..... 171

**8.6.1 Impact of the Frequency and Span Settings**

Some background knowledge on the impact of the described settings is provided here for a better understanding of the required configuration.

- [Defining the Scope of the Measurement - Frequency Range](#)..... 168
- [Coping with Large Frequency Ranges - Logarithmic Scaling](#)..... 169
- [Keeping the Center Frequency Stable - Signal Tracking](#)..... 170

**8.6.1.1 Defining the Scope of the Measurement - Frequency Range**

The frequency range defines the scope of the signal and spectrum to be analyzed.

In the receiver application, the R&S ESW supports several measurement concepts.

- Measurements over a specified frequency range  
The frequency range is defined by start and stop frequency. This concept is usually used by scans. If you are using a scan table, you can split the frequency range into several smaller subranges.
- Measurements on a single frequency  
The measurement is performed on a single frequency. This concept is used by bar-graph measurements, for example.

- Measurements on a set of single frequencies  
The measurement is performed on a set of single frequencies that are within a specified frequency range. This concept is used by the final measurement, for example.
- Measurements within a frequency span around the receiver frequency  
The measurement shows the spectrum around the receiver frequency in greater detail. This concept is used by the IF analysis.

In any way, make sure that the receiver frequency is at least twice as large as the resolution bandwidth. If you use a frequency that is lower, the R&S ESW automatically reduces the measurement bandwidth.

### 8.6.1.2 Coping with Large Frequency Ranges - Logarithmic Scaling

In a linear display, the frequencies are distributed linearly across the x-axis. That means the entire frequency range is divided by the number of measurement points, and the distance between measurement points is equal. Linear scaling is useful to determine precise frequencies within a small range.



**Figure 8-6: Linear x-axis scaling: the distance between the measurement points is equal, e.g. 200 kHz**

However, if high and low frequencies appear in the same display, it is difficult to determine individual frequencies precisely or to distinguish frequencies that are close together.

In a logarithmic display, lower frequencies are distributed among a much larger area of the display, while high frequencies are condensed to a smaller area. Now it is much easier to distinguish several lower frequencies, as they are spread over a wider area. Logarithmic scaling is useful for overview measurements when a large frequency range must be displayed in one diagram.

However, with logarithmic scaling, the frequency resolution between two measurement points deteriorates with higher frequencies.

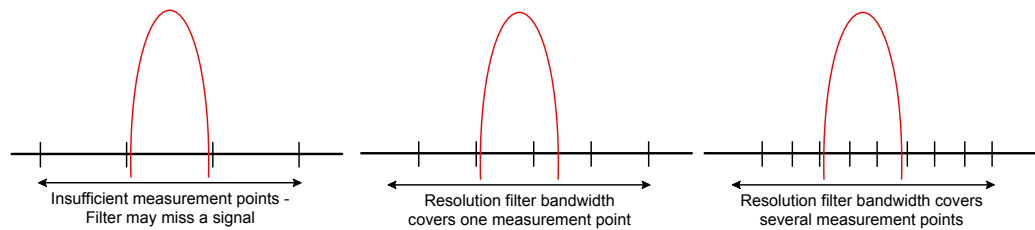

**Figure 8-7: Logarithmic x-axis scaling: the distance between measurement points is variable**

In the spectrum from 10 Hz to 100 Hz, the distance is a few Hz. Between 100 MHz and 1 GHz, the distance is several MHz.

Thus, for logarithmic x-axis scaling, the number of measurement points must be sufficiently high in order to distinguish high frequencies precisely. The resolution bandwidth should cover at least one measurement point (that means: the distance between two measurement points should not exceed the RBW). If this condition is not met, signals or interferers could be missed, especially narrowband interferers.





### 8.6.1.3 Keeping the Center Frequency Stable - Signal Tracking

Note: in the Receiver application, signal tracking is available for the IF analysis.

If the signal drifts on the display but you want to keep the center frequency on the signal peak, the center frequency can be adjusted automatically using **signal tracking**. In this case, the signal trace is surveyed in a specified bandwidth around the expected center frequency. After each sweep, the center frequency is set to the maximum signal found within the searched bandwidth. If no maximum signal above a defined threshold value is found in the searched bandwidth, the center frequency remains unchanged. The search bandwidth and the threshold value are shown in the diagram by red lines which are labeled as "TRK".

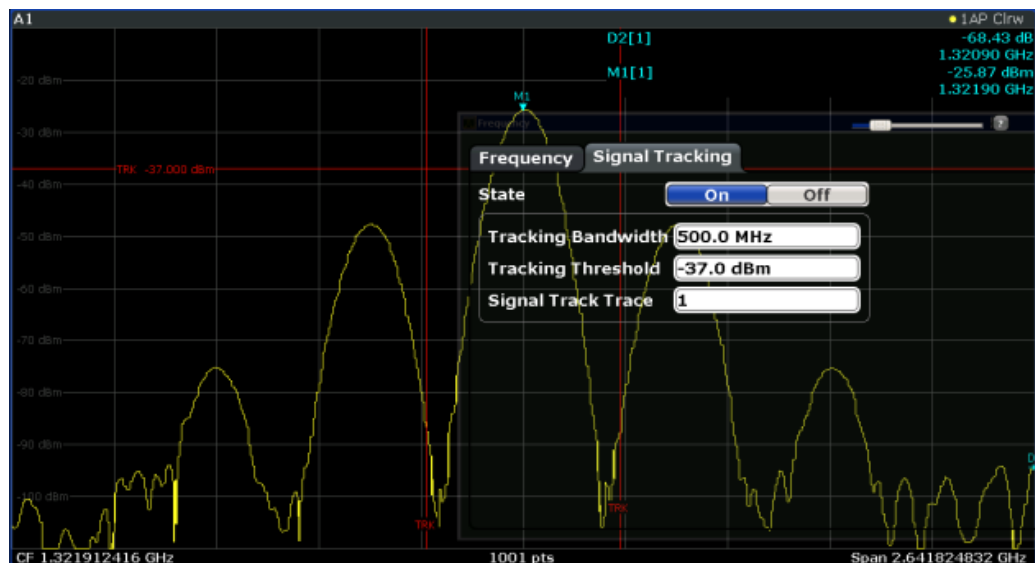

#### Signal Tracking

**Access:** "Overview" > "Frequency" > "Signal Tracking" tab

Defines the settings for signal tracking. These settings are only available for spans > 0.

If activated, after each sweep, the center frequency is set to the maximum level of the specified "Signal Track Trace" found within the searched "Tracking Bandwidth".

If the signal level does not pass the "Tracking Threshold", the center frequency is not changed.

Remote command:

`CALCulate<n>:MARKer<m>:FUNCTION:STRack[:STATe]` on page 491

`CALCulate<n>:MARKer<m>:FUNCTION:STRack:BANDwidth` on page 491

[CALCulate<n>:MARKer<m>:FUNCTION:STRack:THReshold](#) on page 492  
[CALCulate<n>:MARKer<m>:FUNCTION:STRack:TRACe](#) on page 492

## 8.6.2 Frequency and Span Settings

**Access** (general frequency settings): "Overview" > "Frequency" > "Frequency"

**Access** (signal tracking): "Overview" > "Frequency" > "IF Signal Tracking"

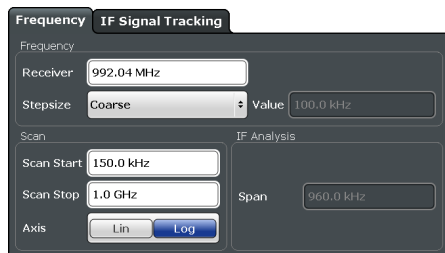

Receiver Frequency.....	171
L Synchronizing the receiver frequency to the marker frequency.....	171
IF Analysis.....	172
Start / Stop Frequency.....	172
Frequency Axis Scale.....	172
Frequency Step size.....	173
IF Signal Tracking.....	173

### Receiver Frequency

Defines the receiver frequency.

Make sure to define a frequency that is at least twice as large as the resolution bandwidth. If you use a frequency that is lower, the R&S ESW automatically reduces the bandwidth.

Note that turning on the low noise preamplifier limits the lower frequency to 150 kHz.

**Tip:** You can add a vertical line to the scan diagram that represents the frequency that the R&S ESW is currently tuned to ( [Tuned Frequency](#) , available in the "Lines" menu).

**Tip:** You can lock the frequency with the corresponding button in the toolbar. If you turn on the frequency lock, the frequency does not change when you turn the rotary knob. Changing the frequency with the cursor keys or the numeric keys still works.

Remote command:

[\[SENSe:\] FREQuency:CENTer](#) on page 493

### Synchronizing the receiver frequency to the marker frequency ← Receiver Frequency

When you are using a marker in the "Scan" result display, you can synchronize the receiver frequency with the current marker position by just moving the marker.

The R&S ESW provides two methods to synchronize marker and receiver frequency.

- "Marker Tracking"  
Tracks the marker position when you move the marker and automatically synchronizes the receiver frequency with the new marker position.

In that case, the bargraph always shows the level at the current marker position.

- "Tune to Marker"  
Synchronizes the receiver frequency and the current marker position once.  
(In fact, this function only has an effect when "Marker Tracking" is turned off, because otherwise, the marker position and frequency are synchronized automatically.)

The R&S ESW always synchronizes to the position of the currently selected marker, even if it is a relative delta marker.

The "Marker Tracking" and "Tune to Marker" softkeys are available in the "Marker To" softkey menu (accessible via the [MKR →] key).

Remote command:

Marker tracking: `CALCulate<n>:MARKer<m>:COUPlEd[:STATE]` on page 530

### IF Analysis

Defines the span and resolution bandwidth for IF analysis.

The **span** defines the spectrum that is analyzed around the receiver frequency. When you change the span, the receiver frequency remains the same.

**Tip:** In the "IF Span" softkey menu, you can quickly set the **full IF span** and the **last IF span** with the corresponding softkeys. The last span is the span that was selected prior to the current span. You can access the "IF Span" menu via the [SPAN] key.

The **resolution bandwidth** (RBW) selects the width of the resolution filter that is used for IF spectrum analysis. Note that the available resolution bandwidths depend on the currently selected span.

In addition, you can couple the IF span to the [Measurement Bandwidth](#) (used for the bargraph).

When "IF Span Coupled" has been turned on, the IF span is a function of the measurement bandwidth.

Remote command:

Span: `[SENSe:]FREQuency:SPAN` on page 493

RBW: `[SENSe:]BANDwidth:IF` on page 498

IF span coupled: `[SENSe:]BANDwidth:SCPL` on page 498

### Start / Stop Frequency

Defines the start and stop frequencies for the scan.

The range for the start frequency is  $f_{\min}$  to  $(f_{\max} - 10 \text{ Hz})$ .

The range for the stop frequency is  $(f_{\min} + 10 \text{ Hz})$  to  $f_{\max}$ .

$f_{\min}$  and  $f_{\max}$  are defined in the datasheet.

Remote command:

Start frequency: `[SENSe:]FREQuency:START` on page 443

Stop frequency: `[SENSe:]FREQuency:STOP` on page 443

### Frequency Axis Scale

Selects the scale of the frequency axis.

#### More information

"Linear"                      Selects a linear scaling of the frequency axis.

"Logarithmic" Selects a logarithmic scaling of the frequency axis.

Remote command:

`DISPlay[:WINDow<n>]:TRACe<t>:X:SPACing` on page 492

### Frequency Stepsize

Defines the stepsize by which the frequency is increased or decreased when you change it with the arrow keys or the rotary knob.

Note that the rotary knob and the arrow keys apply different steps.

When you turn on "Wheel = Up / Down", the rotary knob and cursor keys have the same step size (that of the cursor keys).

"Coarse"	<p>The stepsize is coupled to the receiver frequency.</p> <ul style="list-style-type: none"> <li>When you change the frequency with the rotary knob, the R&amp;S ESW increases or decreases the 4th digit of the receiver frequency.</li> <li>When you change the frequency with the arrow keys, the R&amp;S ESW increases or decreases the 2nd digit of the receiver frequency.</li> </ul>
"Fine"	<p>The stepsize is coupled to the receiver frequency.</p> <ul style="list-style-type: none"> <li>When you change the frequency with the rotary knob, the R&amp;S ESW increases or decreases the 7th digit of the receiver frequency.</li> <li>When you change the frequency with the arrow keys, the R&amp;S ESW increases or decreases the 5th digit of the receiver frequency.</li> </ul>
"Manual"	<p>The stepsize is a fixed custom value.</p> <ul style="list-style-type: none"> <li>When you change the frequency with the rotary knob, the R&amp;S ESW increases or decreases the frequency by 10 % of the manual stepsize.</li> <li>When you change the frequency with the arrow keys, the R&amp;S ESW increases or decreases the frequency by the manual stepsize.</li> </ul>
"Frequency = Stepsize"	<p>The stepsize is equal to the current receiver frequency. This option is useful for measurements of the harmonic content of a signal. Each change of the frequency selects the next harmonic.</p>
"<x> * Meas BW"	<p>The stepsize is a percentage of the measurement bandwidth (10 %, 50 % or a custom percentage).</p>

Remote command:

`[SENSe:]FREQuency:CENTer:STEP` on page 493

### IF Signal Tracking

Defines the characteristics for signal tracking.

When you turn on signal tracking, the R&S ESW tracks the signal and updates the receiver frequency accordingly. The signal is assumed to be at highest level that has been found within the **tracking bandwidth**. The tracking bandwidth defines a search area around the receiver frequency.

You can also define a **tracking threshold**. If the signal level does not pass the threshold, the center frequency is not changed.

If you use more than one trace, you can select the **trace** signal tracking is applied to. Signal tracking is available for IF spectrum analysis and for spans > 0.

[More information.](#)

Remote command:

State: `CALCulate<n>:MARKer<m>:FUNCTION:STRack[:STATE]` on page 491

Bandwidth: `CALCulate<n>:MARKer<m>:FUNCTION:STRack:BANDwidth` on page 491

Threshold: `CALCulate<n>:MARKer<m>:FUNCTION:STRack:THReshold` on page 492

Trace: `CALCulate<n>:MARKer<m>:FUNCTION:STRack:TRACe` on page 492

## 8.7 Bandwidth and Filter Configuration

The basic bandwidth, filter and sweep settings that apply to most measurements are described here. These parameters define how the data is measured and which filters are used.

- [Impact of Bandwidth and Filter Settings](#)..... 174
- [Bandwidth and Filter Settings](#)..... 174

### 8.7.1 Impact of Bandwidth and Filter Settings

For more background information about bandwidths and filters refer to the following topics:

- [Chapter 7.3.1.1, "Selecting the Measurement Bandwidth"](#), on page 97

### 8.7.2 Bandwidth and Filter Settings

Access: "Overview" > "Bandwidth"

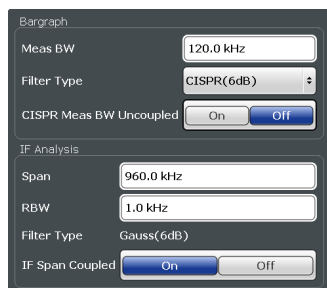

Functions in the "Bandwidth" dialog box described elsewhere:

- ["IF Analysis"](#) on page 172
- ["Measurement Bandwidth"](#) on page 96

- "Filter Type" on page 96

CISPR RBW Uncoupled.....175

#### CISPR RBW Uncoupled

Cancels the coupling of the IF bandwidth to the frequency range with the activated quasipeak detector, CISPR average or RMS average detector.

See also [Chapter 9.3.1.1, "Working with Trace Detectors"](#), on page 190.

Remote command:

`[SENSe:]BANDwidth[:RESolution]:AUTO` on page 499

## 8.8 Trigger Configuration

Triggering means to capture the interesting part of the signal. Choosing the right trigger type and configuring all trigger settings correctly allows you to detect various incidents in your signals.

- [Basics on Triggered Measurements](#)..... 175
- [Triggering Measurements](#)..... 178

### 8.8.1 Basics on Triggered Measurements

- [Trigger Offset](#)..... 175
- [Gated Measurements](#).....175

#### 8.8.1.1 Trigger Offset

An offset can be defined to delay the measurement after the trigger event, or to include data before the actual trigger event in time domain measurements (pre-trigger offset). Pre-trigger offsets are possible because the R&S ESW captures data continuously in the time domain, even before the trigger occurs.

See "[Trigger Offset](#)" on page 180.

#### 8.8.1.2 Gated Measurements

Like a gate provides an opening in a fence, a gated measurement lets data from the input signal pass in defined areas only. The *gate* controls exactly when data is included in the measurement results and when not. The gate is opened by the trigger source, which is also the gate source. Gates can be used in two different modes:

- **Level:** The gate opens and the measurement starts when a defined level in the gate source is exceeded and stops when the gate source drops below the "Gate Level" .  
Using a pulsed gate signal in level mode, the following behavior can be achieved: When the gate source signal is active, the input signal data is collected; when the gate signal is inactive, the input signal is ignored.

- **Edge:** The gate opens and the measurement starts when a defined level in the gate source is exceeded and stops when the defined "Gate Length" is reached.

Additionally, a delay time can be defined so that the first few measurement points after the gate opening are ignored.

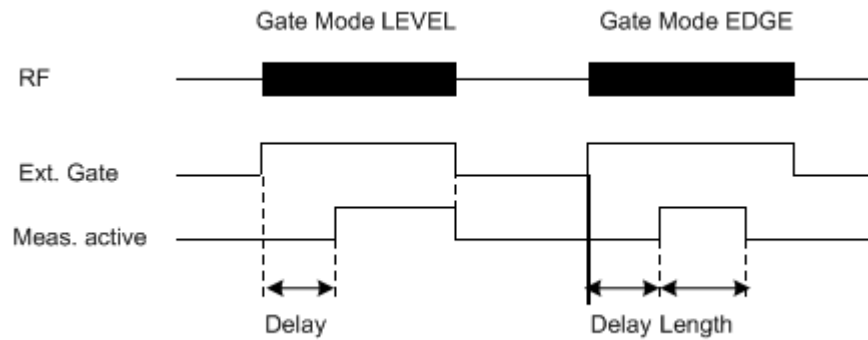
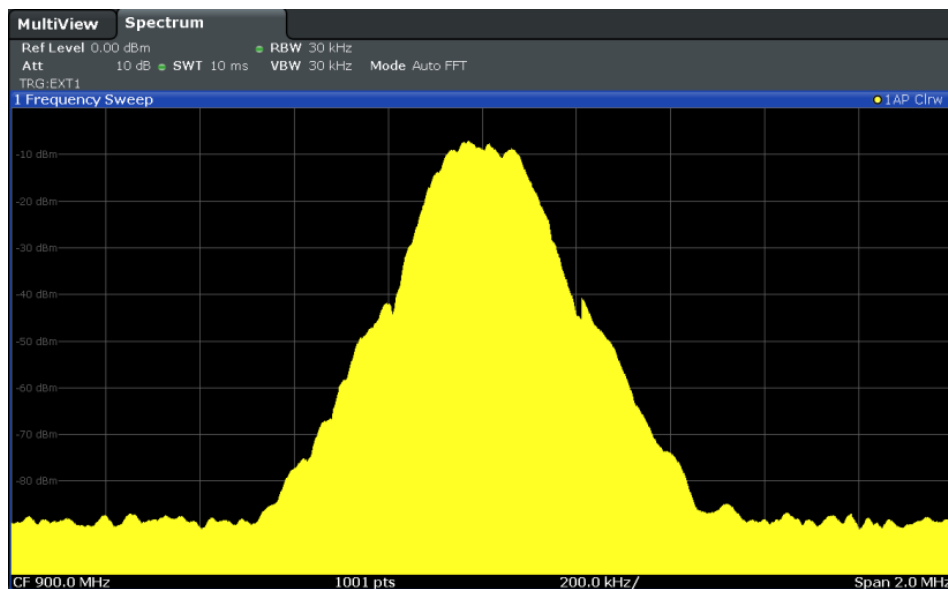

Figure 8-8: Effects of Gate mode, Gate delay and Gate length

**Example:**

By using a gate in sweep mode and stopping the measurement while the gate signal is inactive, the spectrum for pulsed RF carriers can be displayed without the superposition of frequency components generated during switching. Similarly, the spectrum can also be analyzed for an inactive carrier. The sweep can be controlled by an external gate or by the internal power trigger.



*Figure 8-9: GSM signal with GATE OFF*

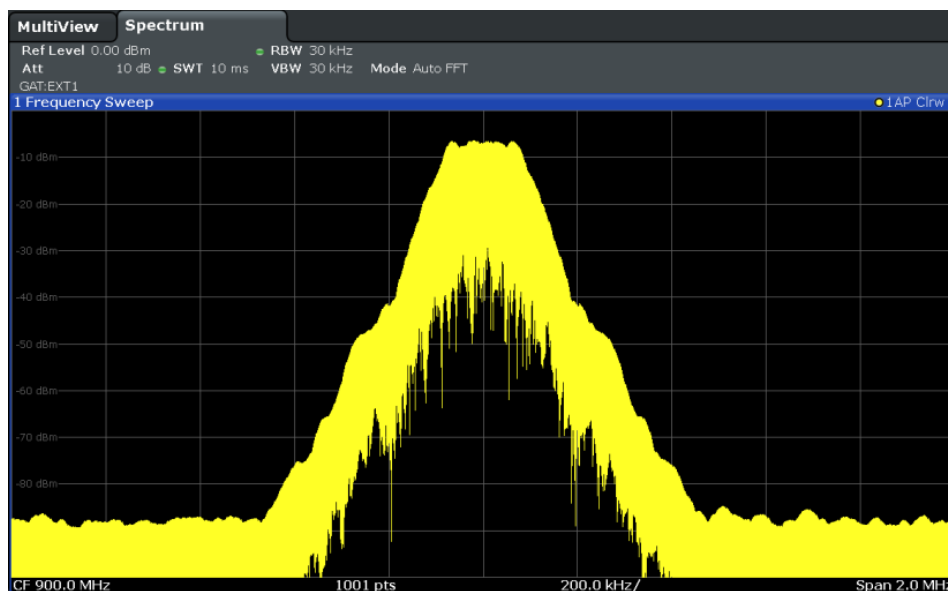

*Figure 8-10: GSM signal with GATE ON*

Gated sweep operation is also possible for zero span measurements. This allows you to display level variations of individual slots, for instance in burst signals, versus time.



To indicate that a gate is used for the sweep, "GAT" and the gate source is displayed in the channel bar.

### Gated measurements in receiver application

Gated measurements are also available in the receiver application. Basically, they work like gated measurements in the spectrum application with some distinctive features.

In the receiver application, a gated measurement affects the bargraph, scan and final measurement. They are useful, for example, when you only want to collect measurement data during times when a DUT is actually running and emits potential interfering signals, or in case you already know that interferers occur regularly and want to collect measurement data during the time when the interference is not present.

The following distinctive features apply.

- The scan is interrupted when the gate is closed. When it reopens, the scan is resumed on the last measured frequency (just like if you have interrupted the scan deliberately).
- Each measurement point is measured for a certain period of time (defined by the [measurement time](#)). If the gate closes before the R&S ESW is done with any particular measurement point, the remaining time is measured when the gate opens again. The actual results in that case are the sum of the partial measurements.

**Example:** The measurement time is 1 second. The gate closes after 0.6 seconds. The data that has already been collected is kept. When the gate opens again, the R&S ESW resumes the measurement for another 0.4 seconds, and combines the two partial measurements.

## 8.8.2 Triggering Measurements

**Access** (trigger source): "Overview" > "Trigger" > "Trigger Source"

**Access** (gate settings): "Overview" > "Trigger" > "Trigger Source"

**Access** (trigger input / output): "Overview" > "Trigger" > "Trigger In / Out"



### Additional trigger ports

The R&S ESW provides three trigger ports. One exclusively serves as a trigger input, while you can configure the other two trigger ports to be a trigger output as well.

For more information about the trigger output see "[Trigger 2/3](#)" on page 161.



Trigger Source.....	179
L Free Run .....	179
L Ext. Trigger 1/2.....	179
Trigger Level.....	179
Trigger Offset.....	180
Trigger Slope.....	180
Gated Trigger .....	180
Gate Mode .....	180
Gate Delay .....	180
Gate Length .....	181

### Trigger Source

Selects the trigger source.

If you select a trigger source other than "Free Run", "TRG" is displayed in the channel bar and the trigger source is indicated.

Remote command:

`TRIGger<n>[:SEquence]:SOURce` on page 503

`[SENSe:]SWEep:EGATe:SOURce` on page 500

### Free Run ← Trigger Source

No trigger source is considered. Data acquisition is started manually or automatically and continues until stopped explicitly.

In its default state, the R&S ESW performs free run measurements.

Remote command:

`TRIGger<n>[:SEquence]:SOURce` on page 503

### Ext. Trigger 1/2 ← Trigger Source

Data acquisition starts when the TTL signal fed into the specified input connector meets or exceeds the specified trigger level.

**Note:** The "External Trigger 1" softkey automatically selects the trigger signal from the TRIGGER 1 INPUT connector on the front panel.

For details, see the "Instrument Tour" chapter in the R&S ESW Getting Started manual.

"External Trigger 1"

Trigger signal from the TRIGGER 1 INPUT connector.

"External Trigger 2"

Trigger signal from the TRIGGER 2 INPUT / OUTPUT connector.

"External Trigger 3"

Trigger signal from the TRIGGER 3 INPUT / OUTPUT connector on the rear panel.

Remote command:

`TRIGger<n>[:SEquence]:SOURce` on page 503

### Trigger Level

Defines the trigger level for the selected trigger source.

Remote command:

`TRIGger<n>[:SEquence]:LEVel[:EXTernal<port>]` on page 502

**Trigger Offset**

Defines the time offset between the trigger event and the start of the sweep.

For more information, see [Chapter 8.8.1.1, "Trigger Offset"](#), on page 175.

- "values > 0"      Measurement starts after the trigger event has occurred.
- "values < 0"      Measurement starts before the trigger event occurs (pretrigger).  
The maximum allowed range is limited by the measurement time.  
Pretriggering is possible in the time domain.

Remote command:

[TRIGger<n>\[:SEQuence\]:HOLDoff\[:TIME\]](#) on page 502

**Trigger Slope**

Selects the polarity of the trigger source.

The trigger slope is unavailable for the free run trigger.

- "Rising"            The measurement starts when the signal rises to the trigger level.
- "Falling"           The measurement starts when the signal falls down to the trigger level.

Remote command:

[TRIGger<n>\[:SEQuence\]:SLOPe](#) on page 503

**Gated Trigger**

Switches gated triggering on or off.

If the gate is switched on, a gate signal applied to one of the TRIGGER INPUT connectors or the internal IF power detector controls the measurement.

**Note:** Gating is not available for measurements on I/Q based data.

Remote command:

[\[SENSe:\]SWEep:EGATe\[:STATe\]](#) on page 501

**Gate Mode**

Sets the gate mode.

For more information see [Chapter 8.8.1.2, "Gated Measurements"](#), on page 175

- "Edge"              The trigger event for the gate to open is the detection of the signal edge.  
After the gate signal has been detected, the gate remains open until the gate length is over.
- "Level"             The trigger event for the gate to open is a particular power level.  
After the gate signal has been detected, the gate remains open until the signal disappears.

Remote command:

[\[SENSe:\]SWEep:EGATe:TYPE](#) on page 501

**Gate Delay**

Defines the delay time between the gate signal and the continuation of the measurement.

In the Spectrum application, the delay position on the time axis in relation to the measurement is indicated by a line labeled "GD" .

For more information see [Chapter 8.8.1.2, "Gated Measurements"](#), on page 175

Remote command:

`[SENSe:] SWEEp:EGATe:HOLDoff` on page 500

### Gate Length

Defines how long the gate is open when it is triggered. The gate length can only be set in the edge-triggered gate mode. In the level-triggered mode the gate length depends on the level of the gate signal.

In the Spectrum application, the gate length in relation to the measurement is indicated by a line labeled "GL".

For more information see [Chapter 8.8.1.2, "Gated Measurements"](#), on page 175

Remote command:

`[SENSe:] SWEEp:EGATe:LENGth` on page 500

## 9 Common Analysis and Display Functions

General methods and basic settings to display and analyze measurements, regardless of the operating mode, are described here. If you are performing a specific measurement task, using an application other than the Receiver application, be sure to check the specific application or mode description for settings and functions that may deviate from these common settings.



The analysis settings and functions are available via the "Analysis" dialog box, which is displayed when you select the "Analysis" button in the "Overview". Additional measurement-specific analysis functions may be available in separate tabs in the "Analysis" dialog box.

- [Result Display Configuration](#)..... 182
- [Zoomed Displays](#)..... 187
- [Trace Configuration](#)..... 189
- [Marker Usage](#)..... 218
- [Display and Limit Lines](#)..... 231

### 9.1 Result Display Configuration

Measurement results can be evaluated in many different ways, for example graphically, as tables, statistical evaluations. Thus, the result display is highly configurable to suit your specific requirements and optimize analysis. Here you can find out how to work and lay out the result display.

General display settings that are usually configured during initial instrument setup, independently of the current measurement, for example which items or colors are displayed on the screen, are described in [Chapter 11.2, "Display Settings"](#), on page 294.

- [Basic Evaluation Methods](#)..... 182
- [Laying out the Result Display with the SmartGrid](#)..... 183

#### 9.1.1 Basic Evaluation Methods

Measurement results can be displayed and evaluated using various different methods, also at the same time. You can control the type and number of results displays and evaluation methods with the SmartGrid functionality.

For more information about the features available through the SmartGrid, refer to the following topics.

- **Bargraph**
  - [Chapter 7.2, "Bargraph Configuration"](#), on page 92
- **Scan**
  - ["Scan"](#) on page 102

- [Chapter 7.3.3, "Performing a Scan"](#), on page 109
- **IF analysis**
  - ["IF Analysis"](#) on page 105
  - ["IF Analysis"](#) on page 172
- **Spectrogram** (for scan and IF analysis)
  - [Chapter 9.3.1.3, "Working with Spectrograms"](#), on page 196
  - [Chapter 9.3.6, "Spectrogram Settings"](#), on page 207
- **Marker table**
  - ["Marker information in marker table"](#) on page 220
- **Peak list**
  - [Chapter 7.3.4, "Performing a Peak Search"](#), on page 117
- **Final measurement**
  - ["Final Measurement"](#) on page 105
  - [Chapter 7.3.5, "Performing Final Measurements"](#), on page 124
- **Preselector**
  - [Chapter 8.4.2, "Configuring the Preselector"](#), on page 142
- **Fast access**
  - [Chapter 8.2, "Using the Fast Access Panel"](#), on page 137

For more information about the SmartGrid in general, see [Chapter 4.5.2, "Laying out the Result Display with the SmartGrid"](#), on page 70.

## 9.1.2 Laying out the Result Display with the SmartGrid

Measurement results can be evaluated in many different ways, for example graphically, as summary tables, statistical evaluations etc. Each type of evaluation is displayed in a separate window in the channel tab. Up to 16 individual windows can be displayed per channel (i.e. per tab). To arrange the diagrams and tables on the screen, the Rohde & Schwarz SmartGrid function helps you find the target position simply and quickly.

Principally, the layout of the windows on the screen is based on an underlying grid, the SmartGrid. However, the SmartGrid is dynamic and flexible, allowing for many different layout possibilities. The SmartGrid functionality provides the following basic features:

- Windows can be arranged in columns or in rows, or in a combination of both.
- Windows can be arranged in up to four rows and four columns.
- Windows are moved simply by dragging them to a new position on the screen, possibly changing the layout of the other windows, as well.
- All evaluation methods available for the currently selected measurement are displayed as icons in the evaluation bar. If the evaluation bar contains more icons than can be displayed at once on the screen, it can be scrolled vertically. The same evaluation method can be displayed in multiple windows simultaneously.
- New windows are added by dragging an evaluation icon from the evaluation bar to the screen. The position of each new window depends on where you drop the evaluation icon in relation to the existing windows.

- All display configuration actions are only possible in SmartGrid mode. When SmartGrid mode is activated, the evaluation bar replaces the current softkey menu display. When the SmartGrid mode is deactivated again, the previous softkey menu display is restored.
- [Background Information: The SmartGrid Principle](#)..... 184
- [How to Activate SmartGrid Mode](#)..... 185
- [How to Add a New Result Window](#)..... 186
- [How to Close a Result Window](#)..... 186
- [How to Arrange the Result Windows](#)..... 187

### 9.1.2.1 Background Information: The SmartGrid Principle

#### SmartGrid display

During any positioning action, the underlying SmartGrid is displayed. Different colors and frames indicate the possible new positions. The position in the SmartGrid where you drop the window determines its position on the screen.

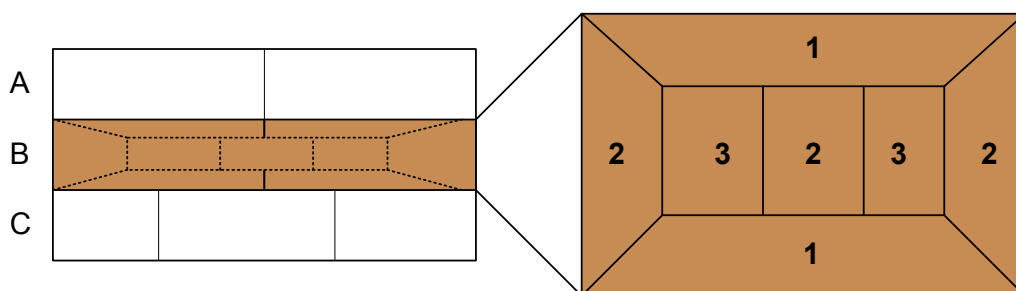

Figure 9-1: Moving a window in SmartGrid mode

The brown area indicates the possible "drop area" for the window, i.e. the area in which the window can be placed. A blue area indicates the (approximate) layout of the window as it would be if the icon were dropped at the current position. The frames indicate the possible destinations of the new window with respect to the existing windows: above/below, right/left or replacement (as illustrated in Figure 4-2). If an existing window would be replaced, the drop area is highlighted in a darker color shade.

### Positioning the window

The screen can be divided into up to four rows. Each row can be split into up to four columns, where each row can have a different number of columns. However, rows always span the entire width of the screen and may not be interrupted by a column. A single row is available as the drop area for the window in the SmartGrid. The row can be split into columns, or a new row can be inserted above or below the existing row (if the maximum of 4 has not yet been reached).



**Figure 9-2: SmartGrid window positions**

- 1 = Insert row above or below the existing row
- 2 = Create a new column in the existing row
- 3 = Replace a window in the existing row

### SmartGrid functions

Once the evaluation icon has been dropped, icons in each window provide delete and move functions.



The "Move" icon allows you to move the position of the window, possibly changing the size and position of the other displayed windows.



The "Delete" icon allows you to close the window, enlarging the display of the remaining windows.

#### 9.1.2.2 How to Activate SmartGrid Mode

All display configuration actions are only possible in SmartGrid mode. In SmartGrid mode the evaluation bar replaces the current softkey menu display. When the SmartGrid mode is deactivated again, the previous softkey menu display is restored.

- ▶ To activate SmartGrid mode, do one of the following:



- Select the "SmartGrid" icon from the toolbar.
- Select the "Display Config" button in the configuration "Overview" .



- Select the "Display Config" softkey from the [MEAS CONFIG] menu.

The SmartGrid functions and the evaluation bar are displayed.



To close the SmartGrid mode and restore the previous softkey menu select the "Close" icon in the right-hand corner of the toolbar, or press any key.

### 9.1.2.3 How to Add a New Result Window

Each type of evaluation is displayed in a separate window. Up to 16 individual windows can be displayed per channel (i.e. per tab).

1. Activate SmartGrid mode.

All evaluation methods available for the currently selected measurement are displayed as icons in the evaluation bar.

2. Select the icon for the required evaluation method from the evaluation bar. If the evaluation bar contains more icons than can be displayed at once on the screen, it can be scrolled vertically. Touch the evaluation bar between the icons and move it up or down until the required icon appears.
3. Drag the required icon from the evaluation bar to the SmartGrid, which is displayed in the diagram area, and drop it at the required position. (See [Chapter 4.5.2.5, "How to Arrange the Result Windows"](#), on page 74 for more information on positioning the window).

**Remote command:**

`LAYout:ADD[:WINDow]?` on page 505 / `LAYout:WINDow<n>:ADD?` on page 509

### 9.1.2.4 How to Close a Result Window

- ▶ To close a window, activate SmartGrid mode and select the "Delete" icon for the window.



**Remote command:**

`LAYout:REMove[:WINDow]` on page 507 / `LAYout:WINDow<n>:REMove` on page 510

### 9.1.2.5 How to Arrange the Result Windows

1. Select an icon from the evaluation bar or the "Move" icon for an existing evaluation window.



2. Drag the evaluation over the SmartGrid.  
A blue area shows where the window will be placed.
3. Move the window until a suitable area is indicated in blue.
4. Drop the window in the target area.  
The windows are rearranged to the selected layout, and "Delete" and "Move" icons are displayed in each window.
5. To close a window, select the corresponding "Delete" icon.



**Remote command:**

`LAYout:REPLace[:WINDow]` on page 507 / `LAYout:WINDow<n>:REPLace` on page 510

## 9.2 Zoomed Displays

You can zoom into the diagram to visualize the measurement results in greater detail. Using the touchscreen or a mouse pointer you can easily define the area to be enlarged.

Zooming into the diagram actually changes the scale of the two diagram axes. New start and stop frequencies are defined as well as a new range for the y-axis, depending on the area you have zoomed into.

For more information see [Chapter 9.2.2, "How to Zoom into the Diagram in Receiver Mode"](#), on page 188.



In the Receiver application, multiple zoom (🔍) is not available.

- [Zoom Functions](#)..... 188
- [How to Zoom into the Diagram in Receiver Mode](#)..... 188

## 9.2.1 Zoom Functions

Access: 

Single Zoom .....	188
Restore Original Display .....	188
 Deactivating Zoom (Selection Mode) .....	188

### Single Zoom



A single zoom replaces the current diagram by a new diagram which displays an enlarged extract of the trace. This function can be used repetitively until the required details are visible.

Remote command:

[DISPlay\[:WINDow<n>\]:ZOOM\[:STATe\]](#) on page 514

[DISPlay\[:WINDow<n>\]:ZOOM:AREA](#) on page 513

### Restore Original Display



Restores the original display, that is, the originally calculated displays for the entire capture buffer, and closes all zoom windows.

Remote command:

[DISPlay\[:WINDow<n>\]:ZOOM\[:STATe\]](#) on page 514

### Deactivating Zoom (Selection Mode)

Deactivates any zoom mode.

Tapping the screen no longer invokes a zoom, but selects an object.

Remote command:

[DISPlay\[:WINDow<n>\]:ZOOM\[:STATe\]](#) on page 514

## 9.2.2 How to Zoom into the Diagram in Receiver Mode

Basically, zooming into a diagram in Receiver mode works the same as in other applications. However, the zoom function in Receiver mode is not merely a visual tool, but actually changes settings. Also, the multiple zoom is not available.

The remote commands required to zoom into a display are described in [Chapter 13.7.2, "Zoomed Displays"](#), on page 513.

### To zoom into the diagram at one position

1. 

Click on the "Single Zoom" icon in the toolbar.

Zoom mode is activated.

2. Select the area in the diagram to be enlarged on the touchscreen. The selected area is indicated by a dotted rectangle.

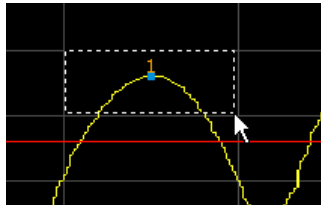

When you leave the touchscreen, the diagram is replaced by the zoomed trace area.

When the zoom is done, the R&S ESW changes the start and stop frequencies, based on the selected zoom area, and adjusts the range of the y-axis. Consequently, future measurements will only span the frequency range of the zoom area. Results yielded prior to the zoom may be lost.

Note that a zoom may also change other measurement settings (for example the measurement bandwidth), depending on the characteristics of the zoom area compared to the original one.

#### Scrolling in the zoomed display

Because zooming defines a new measurement range, scrolling in diagrams that have been zoomed into is not possible.

#### Restoring the original display

To restore the original display, you have to restore the measurement configuration manually by entering the recent start and stop frequencies, bandwidths etc.

## 9.3 Trace Configuration

A trace is a collection of measured data points. The trace settings determine how the measured data is analyzed and displayed on the screen.

• <a href="#">Basics on Traces</a> .....	190
• <a href="#">Trace Configuration</a> .....	203
• <a href="#">Trace Export</a> .....	203
• <a href="#">Copying Traces</a> .....	205
• <a href="#">Trace Mathematics</a> .....	205
• <a href="#">Spectrogram Settings</a> .....	207
• <a href="#">How to Configure Traces</a> .....	211
• <a href="#">References</a> .....	216

### 9.3.1 Basics on Traces

- [Working with Trace Detectors](#)..... 190
- [Analyzing Several Traces - Trace Mode](#)..... 195
- [Working with Spectrograms](#)..... 196

#### 9.3.1.1 Working with Trace Detectors

A trace displays the values measured at the measurement points (also known as sweep points in some applications). Usually, however, the number of measurement points considered during a measurement is much larger than the number of measurement points that can be displayed simultaneously.

For more information on measurement points, see [Chapter 7.3.1.2, "Calculating the Number of Measurement Points"](#), on page 98.

#### Example:

Consider the following configuration:

- Start frequency: 150 kHz
- Stop frequency: 30 MHz
- Step size: 4 kHz
- Measurement time: 100 ms

With said settings, the R&S ESW measures with a dwell time of 100 ms every 4 kHz, so the number of measurement points in that example would be about 7500.

The trace detector's task is to find a good way to combine the measurement points.

The result obtained from the selected detector for any measurement point is displayed as the value at this frequency point in the trace.

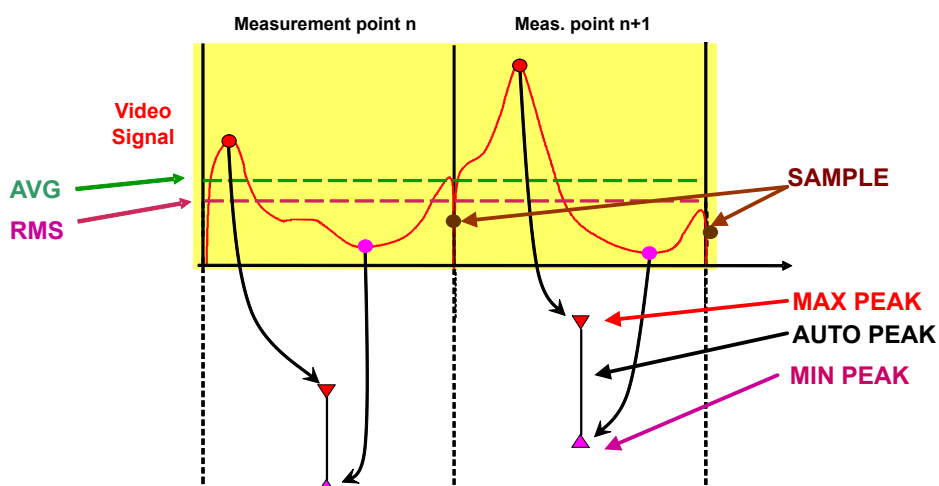

The detectors of the R&S ESW are implemented as digital devices. All detectors work in parallel in the background, which means that the measurement speed is independent of the detector combination used for different traces.

However, you should select a measurement time that is sufficient for the detector that requires the longest measurement time.

You can use several detectors simultaneously. The simultaneous use of several detectors (multiple detection) has advantages for EMC measurements, which often require different weightings: you can test different weightings with a single measurement. In the receiver application, you can even apply different detectors to the bargraph measurement, the scan and the final measurement.

The currently active detector is indicated in the trace information (see the abbreviation in brackets). Note that the detectors mentioned below may not be supported by all applications available for the R&S ESW.

### Automatic Selection of the Detector

Available in the spectrum application.

The application automatically selects an appropriate detector, depending on the selected trace mode.

Trace mode	Detector
"Clear Write"	"Auto Peak"
"Max Hold"	"Positive Peak"
"Min Hold"	"Negative Peak"
"Average"	"Sample Peak"
"View"	–
"Blank"	–

### The Auto Peak Detector

Available in the spectrum application (but not for the Spectrum Emission Mask).

Combines the peak detectors ([Positive and Negative Peak](#)).

The auto peak detector determines the maximum and the minimum value of the levels measured at the individual frequencies which are displayed in one sample point.

### The Positive Peak (or Max Peak) and Negative Peak (or Min Peak) Detector

The positive and negative peak detectors display the maximum or minimum level that has been detected during the measurement.

Tips regarding measurement time:

- Unmodulated signals can be measured with the shortest possible measurement time.
- Pulsed signals require a measurement time that is longer than the expected pulse length. At least one pulse needs to be covered by the measurement time.

The peak detectors are digital detectors. Therefore, discharging is irrelevant even with long measurement times.

### The Average Detector

The average detector displays the average level of the samples that have been captured during the measurement.

For average detection, the video voltage (envelope of IF signal) is averaged over the measurement time. Averaging is digital, i.e. the digitized values of the video voltage are summed up and divided by the number of samples at the end of the measurement time. This corresponds to a filtering with a rectangular window in the time domain and a filtering with  $\sin x/x$  characteristic in the frequency domain.

Tips regarding measurement time:

- Unmodulated signals can be measured with the shortest possible measurement time.
- Modulated signals require a measurement time determined by the lowest modulation frequency to be averaged.
- Pulsed signals require a measurement time that is long enough to capture a sufficient number of pulses. For averaging, a sufficient number of pulses is a number greater than 10.

### The RMS Detector

The RMS detector evaluates the root mean square (RMS) value over the current measurement time and displays the resulting value. The integration time corresponds to the measurement time.

Tips regarding measurement time:

- Unmodulated signals can be measured with the shortest possible measurement time.
- Modulated signals require a measurement time determined by the lowest modulation frequency to be averaged.
- Pulsed signals require a measurement time that is long enough to capture a sufficient number of pulses. For averaging, a sufficient number of pulses is a number greater than 10.



#### The RMS detector and the video bandwidth

When you are using the RMS detector in the spectrum application, the video bandwidth (VBW) in the hardware is bypassed.

Duplicate trace averaging with small VBWs and the RMS detector is therefore not possible. However, the VBW is still considered for calculating the measurement time. This results in a longer measurement time for small VBW values. Thus, you can reduce the VBW to get more stable traces even when you are using the RMS detector. Normally, if the RMS detector is used the measurement time should be increased to get more stable traces.

---

### The Sample Detector

The sample detector displays the first level value that has been measured in a particular statistical bin. All other values that have been measured in such a bin are ignored.

### The Quasipeak Detector

The quasipeak detector displays the maximum value weighted to CISPR 16-1-1 that was detected during the measurement.

Depending on the selected frequency, the R&S ESW automatically selects the detectors and IF bandwidths defined for bands A, B and C/D listed in the following table:

	Band A	Band B	Band C/D
Frequency range	< 150 kHz	150 kHz to 30 MHz	> 30 MHz
Resolution bandwidth	200 Hz	9 kHz	120 kHz
Charge time constant	45 ms	1 ms	1 ms
Discharge time constant	500 ms	160 ms	550 ms
Time constant of the mechanical device	160 ms	160 ms	100 ms

The coupling of the resolution bandwidth to the frequency range with activated quasipeak detector can be canceled using the "CISPR RBW uncoupled" softkey.

Tips regarding measurement time:

- The relatively long time constants of the quasipeak detector result in long measurement times to yield valid results.
- Unknown signals should be measured with a measurement time of at least 1 s. This ensures correct weighting of pulses down to a pulse frequency of 5 Hz.
- Known signals can be measured with a much shorter measurement time.

After internal switching, the R&S ESW waits until the measurement result has stabilized before it starts the actual measurement. Since the level does not change during a frequency scan, known signals (e.g. broadband RFI) can be correctly measured with a much shorter measurement time.

### The CISPR Average Detector

The CISPR Average detector displays a weighted average signal level according to CISPR 16-1-1. The average value according to CISPR 16-1-1 is the maximum value of the linear average that has been detected during the measurement.

The detector is used, for example, to measure pulsed sinusoidal signals with a low pulse frequency. It is calibrated with the rms value of an unmodulated sinusoidal signal. Averaging is with lowpass filters of the 2nd order (simulation of a mechanical instrument).

The lowpass time constants and the IF bandwidths are fixed depending on the frequency. The main parameters are listed in the following table:



	Band A	Band B	Band C/D	Band E
Frequency range	< 150 kHz	150 kHz to 30 MHz	30 MHz to 1 GHz	> 1 GHz
Resolution bandwidth	200 Hz	9 kHz	120 kHz	1 MHz
Time constant of the mechanical device	160 ms	160 ms	100 ms	100 ms

The coupling of the resolution bandwidth to the frequency range with activated CISPR average detector can be canceled using the "CISPR RBW uncoupled" softkey.

Tips regarding measurement time:

- The relatively long time constants of the quasipeak detector result in long measurement times to yield valid results.
- Unknown signals should be measured with a measurement time of at least 1 s. This ensures correct weighting of pulses down to a pulse frequency of 5 Hz.
- Unmodulated sinusoidal signals and signals with a high modulation frequency can be measured with a much shorter measurement time.
- Slowly fluctuating signals or pulsed signals require longer measurement times.



#### Measurement times shorter than 20 ms

With measurement times shorter than 20 ms the detector weighting changes to plain average weighting.

When you change the receiver frequency or the attenuation, the R&S ESW waits until the lowpass filter has settled before starting the measurement. The measurement time in that case depends on the resolution bandwidth and the characteristics of the signal.

#### The RMS Average Detector

The RMS Average detector is a combination of the RMS detector (for pulse repetition frequencies above a corner frequency) and the Average detector (for pulse repetition frequencies below the corner frequency). It thus achieves a pulse response curve with the following characteristics: 10 dB/decade above the corner frequency and 20 dB/decade below the corner frequency. The average value is determined by lowpass filters of the 2nd order (simulation of a mechanical instrument).

The detector is used, for example, to measure broadband emissions and may replace the quasipeak detector in the future.

The filter bandwidth and time constants of the detector are coupled to the receiver frequency.

**Table 9-1: RMS Average detector**

	Band A	Band B	Band C/D	Band E
Frequency range	< 150 kHz	150 kHz to 30 MHz	30 MHz to 1 GHz	> 1 GHz
Resolution bandwidth	200 Hz	9 kHz	120 kHz	1 MHz

	Band A	Band B	Band C/D	Band E
Time constant of the mechanical device	160 ms	160 ms	100 ms	100 ms
Corner frequency	10 Hz	100 Hz	100 Hz	1 kHz

Regarding measurement time, see CISPR Average detector.



### Measurement times shorter than 20 ms

With measurement times shorter than 20 ms the detector weighting changes to plain RMS weighting.

#### 9.3.1.2 Analyzing Several Traces - Trace Mode

If several measurement are performed one after the other, or continuous measurement are performed, the trace mode determines how the data for subsequent traces is processed. After each measurement, the trace mode determines whether:

- The data is frozen (View)
- The data is hidden (Blank)
- The data is replaced by new values (Clear Write)
- The data is replaced selectively (Max Hold, Min Hold, Average)



Each time the trace mode is changed, the selected trace memory is cleared.

The R&S ESW supports the following trace modes:

**Table 9-2: Overview of available trace modes**

Trace Mode	Description
Blank	Hides the selected trace.
Clear Write	Overwrite mode: the trace is overwritten by each measurement. This is the default setting. All available detectors can be selected.
Max Hold	The maximum value is determined over several measurements and displayed. The R&S ESW saves the measurement result in the trace memory only if the new value is greater than the previous one. This mode is especially useful with modulated or pulsed signals. The signal spectrum is filled up upon each measurement until all signal components are detected in a kind of envelope. This mode is not available for statistics measurements.

Trace Mode	Description
Min Hold	<p>The minimum value is determined from several measurements and displayed. The R&amp;S ESW saves the measurement result in the trace memory only if the new value is lower than the previous one.</p> <p>This mode is useful for example for making an unmodulated carrier in a composite signal visible. Noise, interference signals or modulated signals are suppressed, whereas a CW signal is recognized by its constant level.</p> <p>This mode is not available for statistics measurements.</p>
View	The current contents of the trace memory are frozen and displayed.



If a trace is frozen ("View" mode), the measurement settings, apart from scaling settings, can be changed without impact on the displayed trace. The fact that the displayed trace no longer matches the current measurement settings is indicated by a yellow asterisk \* on the tab label.

If you change any parameters that affect the scaling of the diagram axes, the R&S ESW automatically adapts the trace data to the changed display range. This allows you to zoom into the diagram after the measurement to show details of the trace.

### 9.3.1.3 Working with Spectrograms

In addition to the standard "level versus frequency" or "level versus time" traces, the R&S ESW also provides a spectrogram display of the measured data.

A spectrogram shows how the spectral density of a signal varies over time. The x-axis shows the frequency, the y-axis shows the time. A third dimension, the power level, is indicated by different colors. Thus you can see how the strength of the signal varies over time for different frequencies.

**Example:**

(Note that this example is based on data recorded in the Spectrum application. The basic principle of a spectrogram in the Receiver application is the same.)

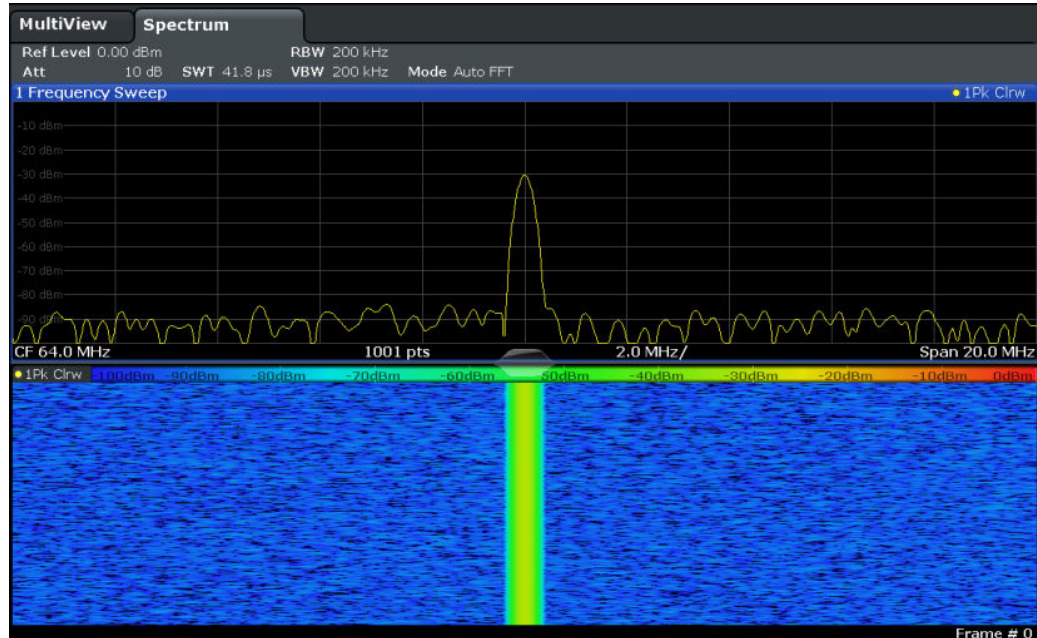

In this example, you see the spectrogram for the calibration signal of the R&S ESW, compared to the standard spectrum display. Since the signal does not change over time, the color of the frequency levels does not change over time, i.e. vertically. The legend above the spectrogram display describes the power levels the colors represent.

**Result display**

The spectrogram result can consist of the following elements:

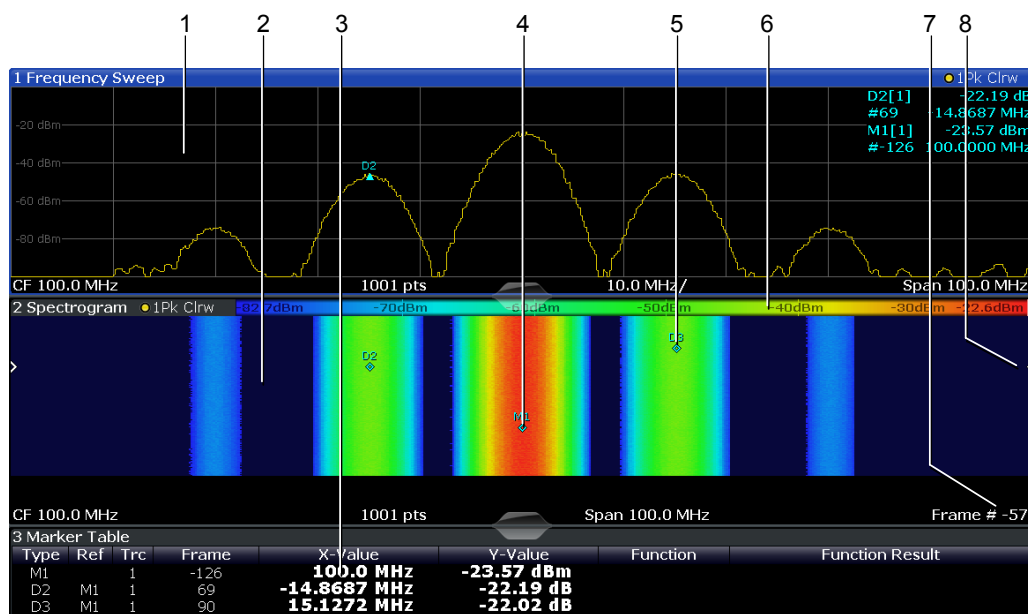

Figure 9-3: Screen layout of the spectrogram result display

- 1 = Spectrum result display
- 2 = Spectrogram result display
- 3 = Marker list
- 4 = Marker
- 5 = Delta marker
- 6 = Color map
- 7 = Timestamp / frame number
- 8 = Current frame indicator

For more information about spectrogram configuration, see [Chapter 9.3.6, "Spectrogram Settings"](#), on page 207.

**Remote commands:**

Activating and configuring spectrograms:

[Chapter 13.7.3.5, "Spectrogram Configuration"](#), on page 518

Storing results:

`MMEMory:STORe<n>:SPECTrogram` on page 606

- [Time Frames](#)..... 198
- [Markers in the Spectrogram](#)..... 199
- [Color Maps](#)..... 200

**Time Frames**

The time information in the spectrogram is displayed vertically, along the y-axis. Each line (or trace) of the y-axis represents one or more captured measurement and is called a **time frame** or simply "frame". As with standard spectrum traces, several measured values are combined in one measurement point using the selected detector.

Frames are sorted in chronological order, beginning with the most recently recorded frame at the top of the diagram (frame number 0). With the next measurement, the previous frame is moved further down in the diagram, until the maximum number of captured frames is reached. The display is updated continuously during the measurement, and the measured trace data is stored. Spectrogram displays are continued even after single measurements unless they are cleared manually.

The maximum number of frames that you can capture depends on the number of measurement points that are analyzed during the measurement.



The scaling of the time axis (y-axis) is not configurable. However, you can enlarge the spectrogram display by maximizing the window using the "Split/Maximize" key.



### Tracking absolute time - timestamps

Alternatively to the frame count, the absolute time (that is: a *timestamp*) at which a frame was captured can be displayed. While the measurement is running, the timestamp shows the system time. In single measurement mode or if the measurement is stopped, the timestamp shows the time and date at the end of the measurement. Thus, the individual frames can be identified by their timestamp or their frame count.

When active, the timestamp replaces the display of the frame number in the diagram footer (see [Figure 9-3](#)).

### Displaying individual frames

The current frame number is indicated in the diagram footer, or alternatively a timestamp, if activated. The current frame, displayed at the top of the diagram, is frame number 0. Older frames further down in the diagram are indicated by a negative index, e.g. "-10". You can display the spectrum diagram of a previous frame by changing the current frame number.

### Markers in the Spectrogram

Markers and delta markers are shaped like diamonds in the spectrogram. They are only displayed in the spectrogram if the marker position is inside the visible area of the spectrogram. If more than two markers are active, the marker values are displayed in a separate marker table.

In the spectrum result display, the markers and their frequency and level values (1) are displayed as usual. Additionally, the frame number is displayed to indicate the position of the marker in time (2).

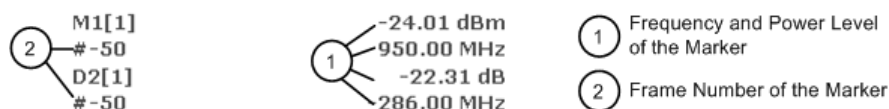

In the spectrogram result display, you can activate up to 16 markers or delta markers at the same time. Each marker can be assigned to a different frame. Therefore, in addition to the frequency you also define the frame number when activating a new

marker. If no frame number is specified, the marker is positioned on the currently selected frame. All markers are visible that are positioned on a visible frame. Special search functions are provided for spectrogram markers.

In the spectrum result display, only the markers positioned on the currently selected frame are visible. In "Continuous Sweep" mode, this means that only markers positioned on frame 0 are visible. To view markers that are positioned on a frame other than frame 0 in the spectrum result display, you must stop the measurement and select the corresponding frame.

### Color Maps

The color display is highly configurable to adapt the spectrograms to your needs. You can define:

- Which colors to use (Color scheme)
- Which value range to apply the color scheme to
- How the colors are distributed within the value range, i.e. where the focus of the visualization lies (shape of the color curve)

The individual colors are assigned to the power levels automatically by the R&S ESW.

### The Color Scheme

- **Hot**



Uses a color range from blue to red. Blue colors indicate low levels, red colors indicate high ones.

- **Cold**



Uses a color range from red to blue. Red colors indicate low levels, blue colors indicate high ones.

The "Cold" color scheme is the inverse "Hot" color scheme.

- **Radar**



Uses a color range from black over green to light turquoise with shades of green in between. Dark colors indicate low levels, light colors indicate high ones.

- **Grayscale**



Shows the results in shades of gray. Dark gray indicates low levels, light gray indicates high ones.

### The Value Range of the Color Map

If the measured values only cover a small area in the spectrogram, you can optimize the displayed value range so it becomes easier to distinguish between values that are close together. Display only parts of interest.

### The Shape and Focus of the Color Curve

The color mapping function assigns a specified color to a specified power level in the spectrogram display. By default, colors on the color map are distributed evenly. However, to visualize a certain area of the value range in greater detail than the rest, you can set the focus of the color mapping to that area. Changing the focus is performed by changing the shape of the color curve.

The color curve is a tool to shift the focus of the color distribution on the color map. By default, the color curve is linear. If you shift the curve to the left or right, the distribution becomes non-linear. The slope of the color curve increases or decreases. One end of the color palette then covers a large range of results, while the other end distributes several colors over a relatively small result range.

You can use this feature to put the focus on a particular region in the diagram and to be able to detect small variations of the signal.



**Example:**

In the color map based on the linear color curve, the range from -100 dBm to -60 dBm is covered by blue and a few shades of green only. The range from -60 dBm to -20 dBm is covered by red, yellow and a few shades of green.

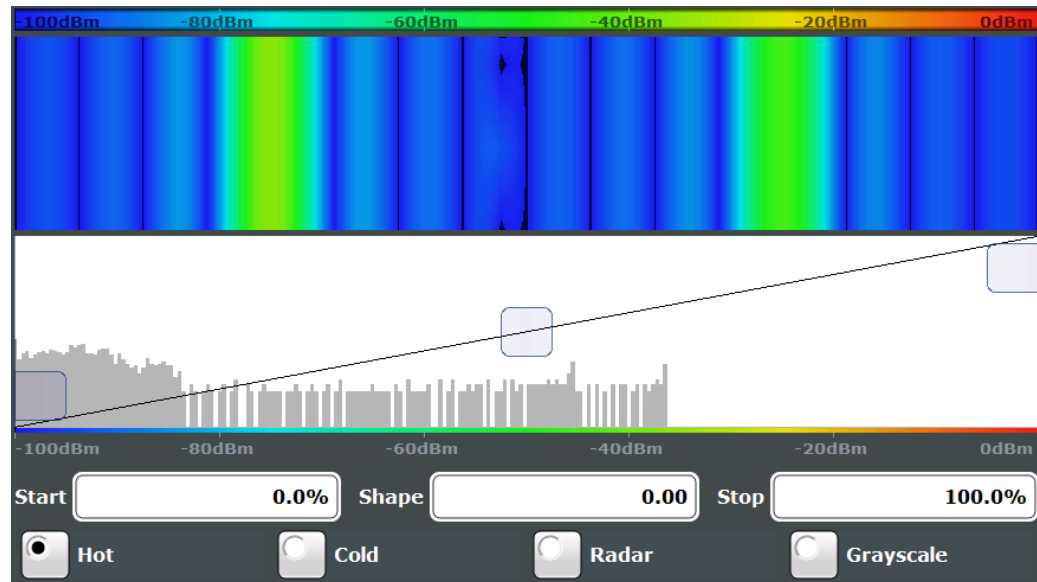

Figure 9-4: Spectrogram with (default) linear color curve shape = 0

The sample spectrogram is dominated by blue and green colors. After shifting the color curve to the left (negative value), more colors cover the range from -100 dBm to -60 dBm (blue, green and yellow). This range occurs more often in the example. The range from -60 dBm to -20 dBm, on the other hand, is dominated by various shades of red only.

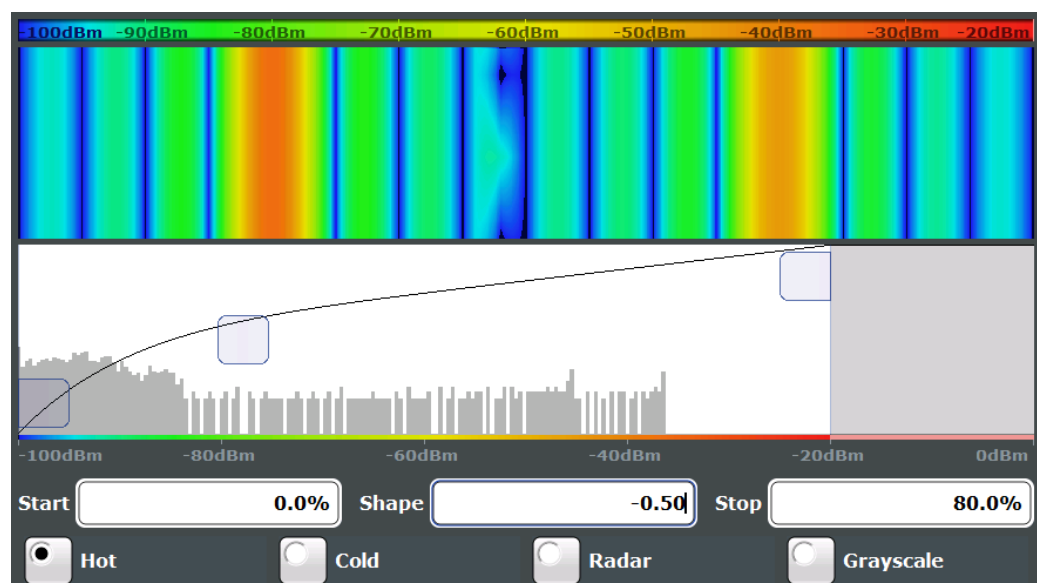

Figure 9-5: Spectrogram with non-linear color curve (shape = -0.5)

### 9.3.2 Trace Configuration

A trace is a collection of measured data points. The trace settings determine how the measured data is analyzed and displayed on the screen.

#### Trace configuration for the scan diagram

The contents of the "Traces" tab of the "Trace Configuration" are the same as the [Traces / Final Meas](#) tab of the "Test Automation" dialog box.

#### Trace configuration for IF analysis

IF analysis supports a maximum of three traces. The "Traces" dialog box available for IF analysis supports the following functions:

- ["Trace Mode"](#) on page 126
- [" Predefined Trace Settings - Quick Config "](#) on page 203

#### Additional trace configuration features

In addition, the "Trace Configuration" for scans provides the following functionality.

[Predefined Trace Settings - Quick Config](#) .....203

#### Predefined Trace Settings - Quick Config

Commonly required trace settings have been predefined and can be applied very quickly by selecting the appropriate button.

Function	Trace Settings	
Preset All Traces	Trace 1:	Clear Write
		Blank
Set Trace Mode Max   Avg   Min	Trace 1:	Max Hold
	Trace 2:	Average
	Trace 3:	Min Hold
		Blank
Set Trace Mode Max   ClrWrite   Min	Trace 1:	Max Hold
	Trace 2:	Clear Write
	Trace 3:	Min Hold
		Blank

### 9.3.3 Trace Export

**Access:** "Overview" > "Analysis" > "Traces" > "Trace Export"

The R&S ESW provides various evaluation methods for the results of the performed measurements. If you want to evaluate the data with other, external applications, you can export the measurement data to a standard ASCII format file (DAT or CSV).

You can also import existing trace data from a file, for example as a reference trace. The trace import is available in the spectrum application.



The standard data management functions (for example saving or loading instrument settings) that are available for all R&S ESW applications are not described here. Refer to the R&S ESW user manual for a description of the standard functions.

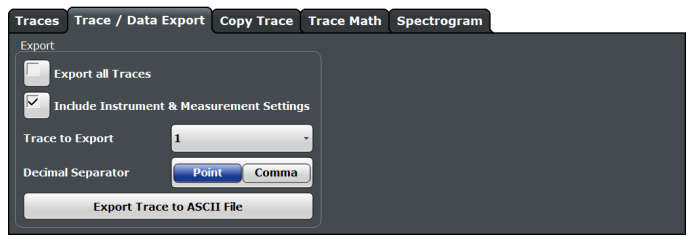

The remote commands required to export traces are described in [Chapter 13.7.3.2, "Trace Export"](#), on page 514.

<a href="#">Export all Traces and all Table Results</a> .....	204
<a href="#">Include Instrument &amp; Measurement Settings</a> .....	204
<a href="#">Trace to Export</a> .....	204
<a href="#">Decimal Separator</a> .....	204
<a href="#">Export Trace to ASCII File</a> .....	205

**Export all Traces and all Table Results**

Selects all displayed traces and result tables (e.g. Result Summary, marker table etc.) in the current application for export to an ASCII file.

Alternatively, you can select one specific trace only for export (see [Trace to Export](#) ).

The results are output in the same order as they are displayed on the screen: window by window, trace by trace, and table row by table row.

Remote command:

[FORMat:DEXPort:TRACes](#) on page 515

**Include Instrument & Measurement Settings**

Includes additional instrument and measurement settings in the header of the export file for result data.

Remote command:

[FORMat:DEXPort:HEADer](#) on page 514

**Trace to Export**

Defines an individual trace that will be exported to a file.

This setting is not available if [Export all Traces and all Table Results](#) is selected.

**Decimal Separator**

Defines the decimal separator for floating-point numerals for the data export/import files. Evaluation programs require different separators in different languages.

Remote command:

[FORMat:DEXPort:DSEParator](#) on page 569

**Export Trace to ASCII File**

Opens a file selection dialog box and saves the selected trace in ASCII format (.dat) to the specified file and directory.

The results are output in the same order as they are displayed on the screen: window by window, trace by trace, and table row by table row.

If the spectrogram display is selected when you perform this function, the entire histogram buffer with all frames is exported to a file. The data for a particular frame begins with information about the frame number and the time that frame was recorded. For large history buffers the export operation may take some time.

Remote command:

MMEMory:STORe<n>:TRACe on page 607

**9.3.4 Copying Traces**

**Access:** "Overview" > "Analysis" > "Traces" > "Copy Trace"

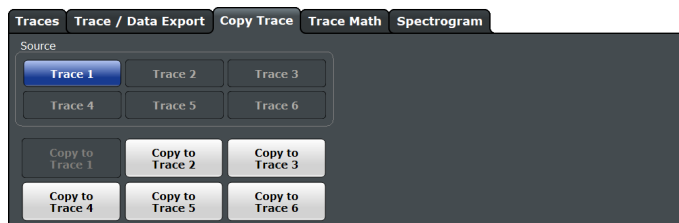

The remote commands required to copy traces are described in [Chapter 13.7.3.3, "Traces Copy"](#), on page 515.

Copy Trace .....205

**Copy Trace**

**Access:** "Overview" > "Analysis" > "Traces" > "Copy Trace"

Copies trace data to another trace.

Remote command:

TRACe<n>:COPY on page 515

**9.3.5 Trace Mathematics**

**Access:** "Overview" > "Analysis" > "Traces" > "Trace Math"

Trace mathematics allow you to combine the data of several traces and write the results to a new trace.

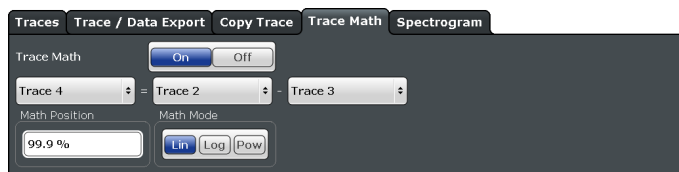

Trace Math Function.....	206
Trace Math Position .....	206
Trace Math Mode .....	206

### Trace Math Function

Trace mathematics subtract the data of one trace from another trace and write the results to a third trace.

When you turn on trace mathematics, you can select all parameters in the equation arbitrarily from the corresponding dropdown menus (both operands and the result). For example, you can subtract trace 1 from trace 3 and write the results to trace 5.

The result is a trace in dB that refers to the zero point defined with the [Trace Math Position](#) setting.

Note that all traces in the equation must have a [trace mode](#) other than "Blank" or "View".

You can turn off all trace mathematics with the "Trace Math Off" feature.

Remote command:

[CALCulate<n>:MATH<t>:EXPRession\[:DEFine\]](#) on page 516

[CALCulate<n>:MATH:STATe](#) on page 517

### Trace Math Position

Defines the zero point on the y-axis of the resulting trace in % of the diagram height. The range of values extends from -100 % to +200 %.

Remote command:

[CALCulate<n>:MATH:POSition](#) on page 517

### Trace Math Mode

Defines the mode for the trace math calculations.

"Lin"	<p>Activates linear subtraction, which means that the power level values are converted into linear units prior to subtraction. After the subtraction, the data is converted back into its original unit.</p> <p>This setting takes effect if the grid is set to a linear scale. In this case, subtraction is done in two ways (depending on the set unit):</p> <ul style="list-style-type: none"> <li>• The unit is set to either W or dBm: the data is converted into W prior to subtraction, i.e. averaging is done in W.</li> <li>• The unit is set to either V, A, dBmV, dBμV, dBμA or dBpW: the data is converted into V prior to subtraction, i.e. subtraction is done in V.</li> </ul>
"Log"	<p>Activates logarithmic subtraction.</p> <p>This subtraction method only takes effect if the grid is set to a logarithmic scale, i.e. the unit of the data is dBm. In this case the values are subtracted in dBm. Otherwise (i.e. with linear scaling) the behavior is the same as with linear subtraction.</p>
"Power"	<p>Activates linear power subtraction.</p> <p>The power level values are converted into unit Watt prior to subtraction. After the subtraction, the data is converted back into its original unit.</p> <p>Unlike the linear mode, the subtraction is always done in W.</p>

Remote command:

`CALCulate<n>:MATH:MODE` on page 516

### 9.3.6 Spectrogram Settings

**Access:** "Overview" > "Analysis" > "Traces" > "Spectrogram"

Functions to configure spectrograms described elsewhere:

- Color mapping: [Chapter 9.3.6.2, "Color Map Settings"](#), on page 209
- Markers: [Chapter 9.4.3.2, "Marker Search \(Spectrogram\)"](#), on page 228

#### Spectrograms in the I/Q Analyzer and Analog Demodulator

Basically, spectrograms in those applications work the same as in the Receiver or Spectrum application.

However, in the I/Q Analyzer and Analog Demodulator, they have the following distinctive features.

- Not all result displays support spectrograms.
- Compared to the Receiver or Spectrum application, a spectrogram can not be added as an independent result display. Instead, spectrograms relate to a certain measurement window (or result display). Result diagram and spectrogram are a single entity in that case and can not be divided.

To view results in a spectrogram, select a window (indicated by a blue frame), then select [TRACE] > "Spectrogram Config".

Spectrograms are either displayed in "Split" mode (spectrogram is displayed below the trace diagram), in "Full" mode (trace diagram is not displayed), or not displayed at all ("Off").

When the "Spectrogram Config" softkey is greyed out, spectrograms are not supported by the selected result display.

- [General Spectrogram Settings](#).....207
- [Color Map Settings](#).....209

#### 9.3.6.1 General Spectrogram Settings

**Access:** "Overview" > "Analysis" > "Traces" > "Spectrogram"

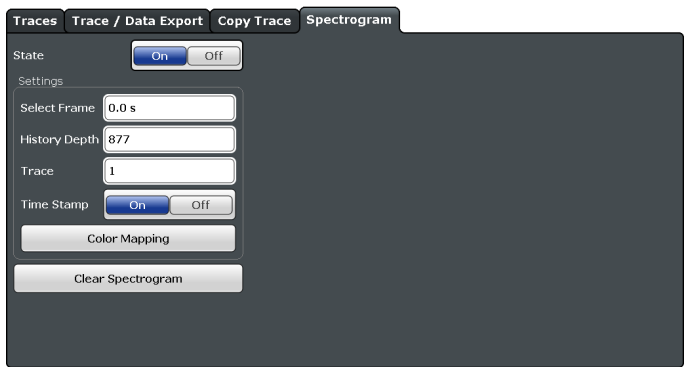

State.....208  
 Select Frame.....208  
 History Depth ..... 208  
 Trace..... 209  
 Time Stamp ..... 209  
 Color Mapping .....209  
 Clear Spectrogram .....209

**State**

Activates and deactivates the spectrogram result display

In the Receiver application, the R&S ESW always records spectrogram data. The "State" function simply controls the spectrogram visibility.

Remote command:

`CALCulate<n>:SPECTrogram[:STATe]` on page 521

**Select Frame**

Selects a specific frame, loads the corresponding trace from the memory, and displays it in the Spectrum window.

Note that activating a marker or changing the position of the active marker automatically selects the frame that belongs to that marker.

This function is only available in single sweep mode or if the sweep is stopped, and only if a spectrogram is selected.

The most recent frame is number 0, all previous frames have a negative number.

Remote command:

`CALCulate<n>:SPECTrogram:FRAMe:SElect` on page 518

**History Depth**

Sets the number of frames that the R&S ESW stores in its memory.

The maximum possible size of the spectrogram history depends on the available memory.

If the memory is full, the R&S ESW deletes the oldest frames stored in the memory and replaces them with the new data.

Remote command:

`CALCulate<n>:SPECTrogram:HDEPth` on page 519

**Trace**

Selects the trace the spectrogram is based on.

You can select any trace that is currently active, including the trace that shows the results of [trace mathematics](#).

Remote command:

[CALCulate<n>:SPECTrogram:TRACe](#) on page 519

**Time Stamp**

Activates and deactivates the timestamp. The timestamp shows the system time while the measurement is running. In single sweep mode or if the measurement is stopped, the timestamp shows the time and date of the end of the measurement.

When active, the timestamp replaces the display of the frame number.

Remote command:

[CALCulate<n>:SPECTrogram:TSTamp\[:STATe\]](#) on page 521

[CALCulate<n>:SPECTrogram:TSTamp:DATA?](#) on page 520

**Color Mapping**

Opens the "Color Mapping" dialog.

For details see ["Color Maps"](#) on page 200.

**Clear Spectrogram**

Resets the spectrogram result display and clears the history buffer.

This function is only available if a spectrogram is selected.

Remote command:

[CALCulate<n>:SPECTrogram:CLEar\[:IMMEDIATE\]](#) on page 518

**9.3.6.2 Color Map Settings**

**Access:** "Overview" > "Analysis" > "Traces" > "Spectrogram" > "Color Mapping"

In addition to the available color settings, the dialog box displays the current color map and provides a preview of the display with the current settings.



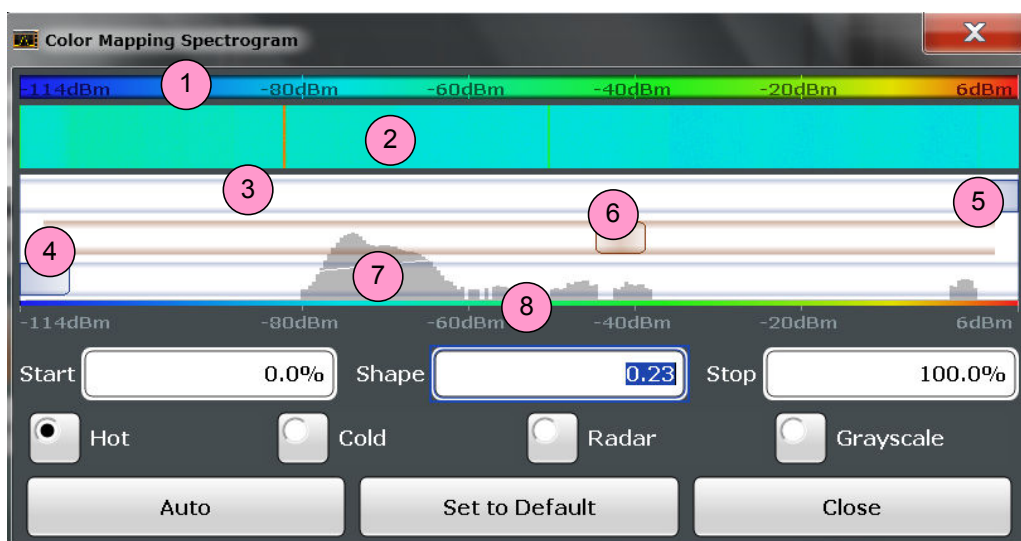

Figure 9-6: Color Mapping dialog box

- 1 = Color map: shows the current color distribution
- 2 = Preview pane: shows a preview of the spectrogram with any changes that you make to the color scheme
- 3 = Color curve pane: graphical representation of all settings available to customize the color scheme
- 4/5 = Color range start and stop sliders: define the range of the color map or amplitudes for the spectrogram
- 6 = Color curve slider: adjusts the focus of the color curve
- 7 = Histogram: shows the distribution of measured values
- 8 = Scale of the horizontal axis (value range)

The remote commands required to configure the color map are described in "Color Map Configuration" on page 522.

Start / Stop .....	210
Shape .....	210
Hot / Cold / Radar / Grayscale .....	211
Auto .....	211
Set to Default .....	211
Close.....	211

**Start / Stop**

Defines the lower and upper boundaries of the value range of the spectrogram.

Remote command:

`DISPlay[:WINDow<n>]:SPECTrogram:COLor:LOWer` on page 522

`DISPlay[:WINDow<n>]:SPECTrogram:COLor:UPPer` on page 523

**Shape**

Defines the shape and focus of the color curve for the spectrogram result display.

"-1 to <0" More colors are distributed among the lower values

"0" Colors are distributed linearly among the values

">0 to 1" More colors are distributed among the higher values

Remote command:

`DISPlay[:WINDow<n>]:SPECTrogram:COLor:SHAPE` on page 522

**Hot / Cold / Radar / Grayscale**

Sets the color scheme for the spectrogram.

Remote command:

`DISPlay[:WINDow<n>]:SPEctrogram:COLor[:STYLe]` on page 523

**Auto**

Defines the color range automatically according to the existing measured values for optimized display.

**Set to Default**

Sets the color mapping to the default settings.

Remote command:

`DISPlay[:WINDow<n>]:SPEctrogram:COLor:DEFault` on page 522

**Close**

Saves the changes and closes the dialog box.

**9.3.7 How to Configure Traces**

- [How to Export Trace Data and Numerical Results](#).....211
- [How to Display and Configure a Spectrogram](#).....212

**9.3.7.1 How to Export Trace Data and Numerical Results**

The measured trace data and numerical measurement results in tables can be exported to an ASCII file. For each measurement point the measured trace position and value are output.

The file is stored with a `.DAT` extension. For details on the storage format see [Chapter 9.3.8.1, "Reference: ASCII File Export Format"](#), on page 216.

**To export trace data and table results**

1. Select [TRACE] > "Trace Config" > "Trace / Data Export" tab.
2. Select "Export all Traces and all Table Results" to export all available measurement result data for the current application, or select a specific "Trace to Export" .
3. Optionally, select the "Include Instrument & Measurement Settings" option to insert additional information in the export file header.
4. If necessary, change the decimal separator to be used for the ASCII export file.
5. Select the "Export Trace to ASCII File" button.
6. In the file selection dialog box, select the storage location and file name for the export file.
7. Select "Save" to close the dialog box and export the data to the file.

### 9.3.7.2 How to Display and Configure a Spectrogram

Step-by-step instructions on how to display and configure a spectrogram are provided here. For details on individual functions and settings see [Chapter 9.3.6, "Spectrogram Settings"](#), on page 207.

The remote commands required to perform these tasks are described in [Chapter 13.7.3.5, "Spectrogram Configuration"](#), on page 518.

The following tasks are described here:

- ["To display a spectrogram"](#) on page 212
- ["To remove the spectrogram display"](#) on page 212
- ["To set a marker in the spectrogram"](#) on page 213
- ["To configure a spectrogram"](#) on page 213
- ["To select a color scheme"](#) on page 214
- ["To set the value range graphically using the color range sliders"](#) on page 214
- ["To set the value range of the color map numerically"](#) on page 214
- ["To set the color curve shape graphically using the slider"](#) on page 215
- ["To set the color curve shape numerically"](#) on page 215

#### To display a spectrogram

1. In the "Overview" , select "Display" , then drag the evaluation type "Spectrogram" to the diagram area.  
Alternatively:
  - a) Select the [TRACE] key and then the "Spectrogram Config" softkey.
  - b) Toggle "Spectrogram" to "On" .
2. To clear an existing spectrogram display, select "Clear Spectrogram" .
3. Start a new measurement using [RUN SINGLE] or [RUN CONT].  
The spectrogram is updated continuously with each new sweep.
4. To display the spectrum diagram for a specific time frame:
  - a) Stop the continuous measurement or wait until the single sweep is completed.
  - b) Select the frame number in the diagram footer.
  - c) Enter the required frame number in the edit dialog box.  
Note that the most recent sweep is frame number 0, all previous frames have negative numbers.

#### To remove the spectrogram display

1. Select the [TRACE] key and then the "Spectrogram Config" softkey.
2. Toggle "Spectrogram" to "Off" .  
The standard spectrum display is restored.

### To set a marker in the spectrogram

1. While a spectrogram is displayed, select the [MARKER] key.
2. Select a "Marker" softkey.
3. Enter the frequency or time (x-value) of the marker or delta marker.
4. Enter the frame number for which the marker is to be set, for example 0 for the current frame, or -2 for the second to last frame. Note that the frame number is always 0 or a negative value!

The marker is only visible in the spectrum diagram if it is defined for the currently selected frame. In the spectrogram result display all markers are visible that are positioned on a visible frame.

### To configure a spectrogram

1. Configure the spectrogram frames:
  - a) Select the [SWEEP] key.
  - b) Select the "Sweep Config" softkey.
  - c) In the "Sweep/Average Count" field, define how many sweeps are to be analyzed to create a single frame.
  - d) In the "Frame Count" field, define how many frames are to be plotted during a single sweep measurement.
  - e) To include frames from previous sweeps in the analysis of the new frame (for "Max Hold", "Min Hold" and "Average" trace modes only), select "Continue Frame" = "On" .
2. Define how many frames are to be stored in total:
  - a) Select the [TRACE] key and then the "Spectrogram Config" softkey.
  - b) Select the "History Depth" softkey.
  - c) Enter the maximum number of frames to store.
3. Optionally, replace the frame number by a time stamp by toggling the "Time Stamp" softkey to "On" .
4. If necessary, adapt the color mapping for the spectrogram to a different value range or color scheme as described in ["How to Configure the Color Mapping"](#) on page 213.

### How to Configure the Color Mapping

The color display is highly configurable to adapt the spectrogram to your needs.

The settings for color mapping are defined in the "Color Mapping" dialog box. To display this dialog box, do one of the following:

- Select the color map in the window title bar of the Spectrogram result display.

### To select a color scheme

You can select which colors are assigned to the measured values.

- ▶ In the "Color Mapping" dialog box, select the option for the color scheme to be used.

### Editing the value range of the color map

The distribution of the measured values is displayed as a histogram in the "Color Mapping" dialog box. To cover the entire measurement value range, make sure the first and last bar of the histogram are included.

To ignore noise in a spectrogram, for example, exclude the lower power levels from the histogram.



The value range of the color map must cover at least 10% of the value range on the horizontal axis of the diagram, that means, the difference between the start and stop values must be at least 10%.

The value range of the color map can be set numerically or graphically.

### To set the value range graphically using the color range sliders

1. Select and drag the bottom color curve slider (indicated by a gray box at the left of the color curve pane) to the lowest value you want to include in the color mapping.
2. Select and drag the top color curve slider (indicated by a gray box at the right of the color curve pane) to the highest value you want to include in the color mapping.

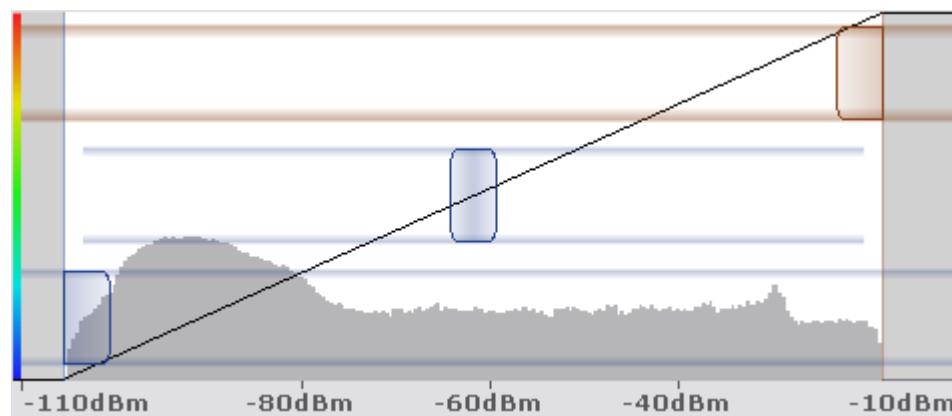

### To set the value range of the color map numerically

1. In the "Start" field, enter the percentage from the left border of the histogram that marks the beginning of the value range.
2. In the "Stop" field, enter the percentage from the right border of the histogram that marks the end of the value range.

**Example:**

The color map starts at -110 dBm and ends at -10 dBm (that is: a range of 100 dB). In order to suppress the noise, you only want the color map to start at -90 dBm. Thus, you enter *10%* in the "Start" field. The R&S ESW shifts the start point 10% to the right, to -90 dBm.

**Adjusting the reference level and level range**

Since the color map is configured using percentages of the total value range, changing the reference level and level range of the measurement (and thus the power value range) also affects the color mapping in the spectrogram.

**Editing the shape of the color curve**

The color curve is a tool to shift the focus of the color distribution on the color map. By default, the color curve is linear, i.e. the colors on the color map are distributed evenly. If you shift the curve to the left or right, the distribution becomes non-linear. The slope of the color curve increases or decreases. One end of the color palette then covers a large number of results, while the other end distributes several colors over a relatively small result range.

The color curve shape can be set numerically or graphically.

**To set the color curve shape graphically using the slider**

- ▶ Select and drag the color curve shape slider (indicated by a gray box in the middle of the color curve) to the left or right. The area beneath the slider is focused, i.e. more colors are distributed there.

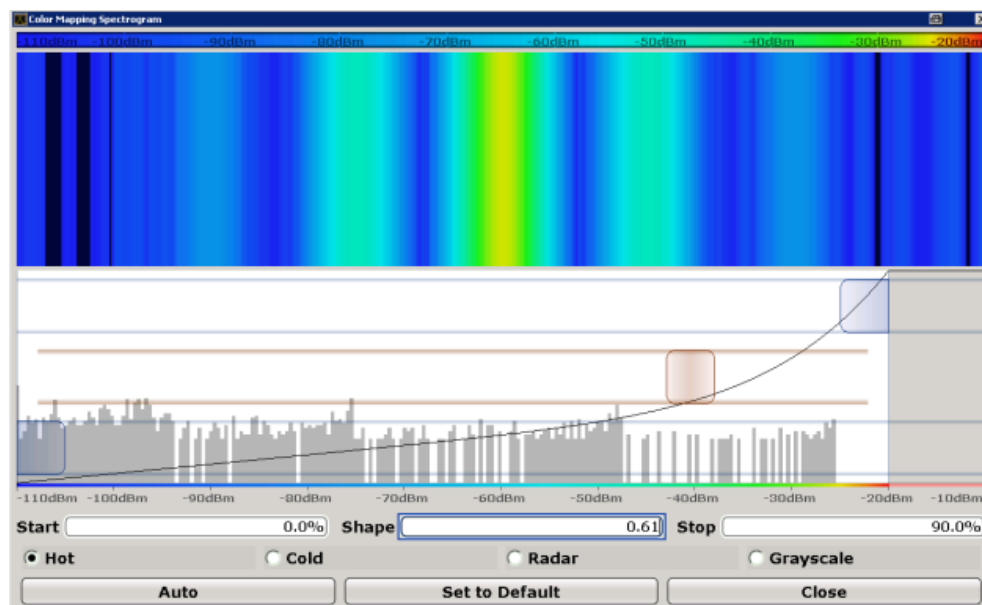
**To set the color curve shape numerically**

- ▶ In the "Shape" field, enter a value to change the shape of the curve:

- A negative value (-1 to <0) focuses the lower values
- 0 defines a linear distribution
- A positive value (>0 to 1) focuses the higher values

### 9.3.8 References

- [Reference: ASCII File Export Format](#).....216

#### 9.3.8.1 Reference: ASCII File Export Format

Trace data can be exported to a file in ASCII format for further evaluation in other applications. This reference describes in detail the format of the export files for result data.

(For details see [Chapter 9.3.7.1, "How to Export Trace Data and Numerical Results"](#), on page 211).

The file consists of the header information (general configuration of the measurement) and the measurement results. Optionally, the header can be excluded from the file.

The data of the file header consist of three columns, each separated by a semicolon: parameter name; numeric value; basic unit. The data section starts with the keyword "Trace <n>" (<n> = number of stored trace), followed by the measured data in one or several columns (depending on the measurement) which are also separated by a semicolon.

The results are output in the same order as they are displayed on the screen: window by window, trace by trace, and table row by table row.

Generally, the format of this ASCII file can be processed by spreadsheet calculation programs, e.g. MS Excel. Different language versions of evaluation programs may require a different handling of the decimal point. Thus you can define the decimal separator to be used (decimal point or comma).

If the spectrogram display is selected when you select the "ASCII Trace Export" soft-key, the entire histogram buffer with all frames is exported to a file. The data corresponding to a particular frame begins with information about the frame number and the time that frame was recorded.

<b>Header</b>	
Type;<instrument_model>;	Instrument model
Version;1.00;	Firmware version
Date;01. Jan 3000;	Date of data set storage
Mode;Receiver;	Application
Start;150000.000000;Hz;	Scan start
Stop;1000000.000000;Hz;	Scan stop
X-Axis;LIN;	Scale of the x-axis
Scan Count;1;	Scan count
Transducer Input1;;;;;;;	List of transducer on input 1
Transducer Input2;;;;;;;	List of transducer on input 2
Preselector;	Preselector configuration
State;On;	
Filter Split;On;	
Notch Filter 1;On;	State of the first notch filter
Notch Filter 2;Off;	State of the second notch filter

<b>Data section (scan ranges)</b>	
Scan 1:	
Start;150000.000000;Hz;	Start frequency of the scan range
Stop;29998500.000000;Hz;	Stop frequency of the scan range
Step;4500.000000;Hz;	Frequency stepsize applied in the scan range
RBW;9000.000000;Hz;	Measurement bandwidth applied in the scan range
Meas Time;0.001000;s;	Measurement time in the scan range
Auto Ranging;OFF;	State of the auto ranging feature
RF Att;10.000000;dB;	Attenuation applied in the scan range
Auto Preamp;OFF; Preamp;0.000000;dB;	Preamplifier information for the scan range
RF Input;1;	RF input used in the scan range
Scan 2:	
(...)	

<b>Data section (traces)</b>	
Trace 1:	
Trace Mode;CLR/WRITE;	Trace mode
Scan Detector;MAX PEAK;	Detector type
X-Unit;Hz;	Unit of the x-axis
Y-Unit;Hz;	Unit of the y-axis
Values;1343;	Number of measurement points
150000.000000;3.541122; 154500.000000;5.776306;[...]	String of results
Trace 2:	
(...)	



## 9.4 Marker Usage

Markers help you analyze your measurement results by determining particular values in the diagram. Thus you can extract numeric values from a graphical display both in the time and frequency domain.



### Markers in spectrogram displays

In the spectrogram result display, you can activate up to 17 markers or delta markers at the same time. Each marker can be assigned to a different frame. Therefore, in addition to the frequency you also define the frame number when activating a new marker. If no frame number is specified, the marker is positioned on the currently selected frame. All markers are visible that are positioned on a visible frame.

- [Basics on Markers](#).....218
- [Marker Settings](#)..... 222
- [Marker Search Settings and Positioning Functions](#)..... 226

### 9.4.1 Basics on Markers

Some background knowledge on marker settings and functions is provided here for a better understanding of the required configuration settings.

Markers are used to mark points on traces, to read out measurement results and to select a display section quickly. The R&S ESW provides 16 markers per display window. In the Spectrum application, the same markers are displayed in all windows.

- The easiest way to work with markers is using the touch screen. Simply drag the marker and drop it at the required position. When a marker label is selected, a vertical line is displayed which indicates the marker's current x-value.

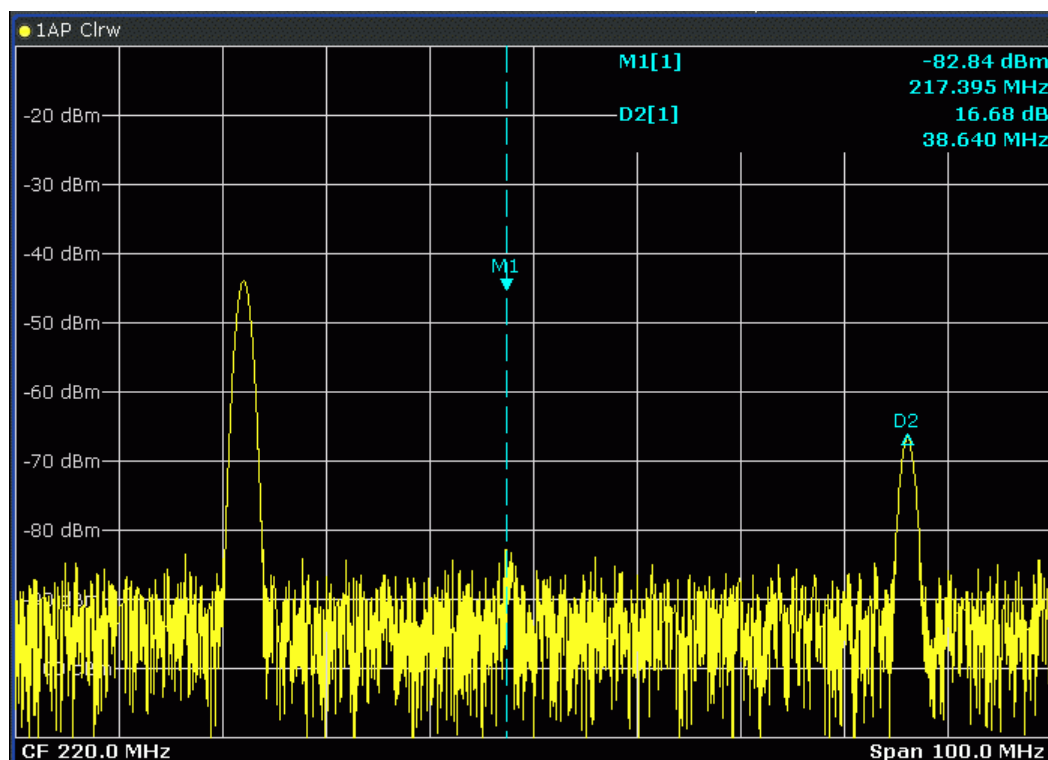

- Alternatively, change the position of the selected marker using the rotary knob. By default, the marker is moved from one pixel to the next. If you need to position the marker more precisely, change the step size to move from one measurement point to the next (General Marker Setting).
  - You can also set an active marker to a new position by defining its x-position numerically. When you select the softkey for a marker, an edit dialog box is displayed.
  - The most commonly required marker settings and functions are also available as softkeys or via the context menu. Tap the marker on the touch screen and hold your finger for about 2 seconds until the context menu is opened, then select the required entry.
  - Softkeys for active markers (displayed on the screen) are highlighted blue. The softkey for the currently selected marker (for which functions are performed) is highlighted orange.
  - To set individual markers very quickly, use the softkeys in the "Marker" menu.
  - To set up several markers at once, use the "Marker" dialog box.
  - To position the selected marker to a special value, use the softkeys in the "Marker To" menu.
- [Marker Results](#).....220
  - [Searching for Signal Peaks](#).....220

### 9.4.1.1 Marker Results

The results can be displayed directly within the diagram area or in a separate table. By default, the first two active markers are displayed in the diagram area. If more markers are activated, the results are displayed in a marker table.

#### Marker information in diagram area

By default, the results of the last two markers or delta markers that were activated are displayed in the diagram area.

D2[1]	-21.90 dB
	-3.9180 GHz
M1[1]	-25.87 dBm
	13.1970 GHz

The following information is displayed there:

- The marker type (M for normal, D for delta, or special function name)
- The marker number (1 to 16)
- The assigned trace number in square brackets [ ]
- The marker value on the y-axis, or the result of the marker function
- The marker position on the x-axis

#### Marker information in marker table

In addition to the marker information displayed within the diagram area, a separate marker table may be displayed beneath the diagram. This table provides the following information for all active markers:

**Table 9-3: Contents of the marker table in the Receiver application**

<b>Wnd</b>	Window type the marker is positioned in.
<b>Type</b>	Marker type: N (normal), D (delta), T (temporary, internal) and number
<b>Ref</b>	Reference marker for delta markers
<b>Trc</b>	Trace to which the marker is assigned
<b>X-value</b>	X-value of the marker
<b>Y-value</b>	Y-value of the marker

### 9.4.1.2 Searching for Signal Peaks

A common measurement task is to determine peak values, i.e. maximum or minimum signal levels. The R&S ESW provides various peak search functions and applications:

- Setting a marker to a peak value once (Peak Search)
- Searching for a peak value within a restricted search area (Search Limits)
- Creating a marker table with all or a defined number of peak values for one measurement (Marker Peak List)

- Updating the marker position to the current peak value automatically after each measurement (Auto Peak Search)
- Creating a fixed reference marker at the current peak value of a trace (Fixed Reference)

Note that the marker peak search is independent of the peak search available for automated test sequences. For more information, see [Chapter 7.3.4, "Performing a Peak Search"](#), on page 117.

### Peak search limits

The peak search can be restricted to a search area. The search area is defined by limit lines which are also indicated in the diagram. In addition, a minimum value (threshold) can be defined as a further search condition.

### When is a peak a peak? - Peak excursion

During a peak search, for example when a marker peak table is displayed, noise values may be detected as a peak if the signal is very flat or does not contain many peaks. Therefore, you can define a relative threshold ("Peak excursion"). The signal level must increase by the threshold value before falling again before a peak is detected. To avoid identifying noise peaks as maxima or minima, enter a peak excursion value that is higher than the difference between the highest and the lowest value measured for the displayed inherent noise.

### Effect of peak excursion settings (example)

The following figure shows a trace to be analyzed.

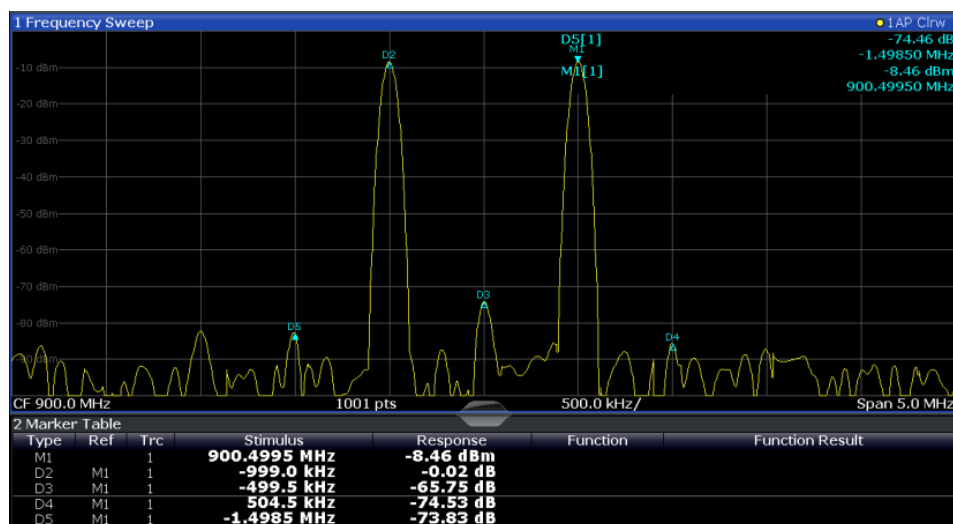

Figure 9-7: Trace example

The following table lists the peaks as indicated by the marker numbers in the diagram above, as well as the minimum decrease in amplitude to either side of the peak:

Marker #	Min. amplitude decrease to either side of the signal
1	30 dB
2	29.85 dB
3	20 dB
4	10 dB
5	18 dB

In order to eliminate the smaller peaks M3,M4 and M5 in the example above, a peak excursion of at least 20 dB is required. In this case, the amplitude must rise at least 20 dB before falling again before a peak is detected.

### Marker peak list

The marker peak list determines the frequencies and levels of peaks in the spectrum. It is updated automatically after each measurement. How many peaks are displayed can be defined, as well as the sort order. In addition, the detected peaks can be indicated in the diagram. The peak list can also be exported to a file for analysis in an external application.

### Automatic peak search

A peak search can be repeated automatically after each measurement in order to keep the maximum value as the reference point for a phase noise measurement. This is useful to track a drifting source. The delta marker 2, which shows the phase noise measurement result, keeps the delta frequency value. Therefore the phase noise measurement leads to reliable results in a certain offset although the source is drifting.

In the Receiver application, the R&S ESW provides an automatic peak search. In that case, the R&S ESW searches for peaks when a scan is over. The search results are added to the marker peak list as usual and are the basis for the final measurement. For more information, see [Chapter 7.3.4, "Performing a Peak Search"](#), on page 117.

### Using a peak as a fixed reference marker

Some results are analyzed in relation to a peak value, for example a carrier frequency level. In this case, the maximum level can be determined by an initial peak search and then be used as a reference point for further measurement results.

## 9.4.2 Marker Settings

**Access:** "Overview" > "Analysis" > "Marker"

The remote commands required to define these settings are described in [Chapter 13.7.4, "Markers"](#), on page 524.

- [Individual Marker Setup](#)..... 223
- [General Marker Settings](#)..... 225

### 9.4.2.1 Individual Marker Setup

**Access:** "Overview" > "Analysis" > "Marker" > "Markers"

Up to 17 markers or delta markers can be activated for each window simultaneously. Initial marker setup is performed using the "Marker" dialog box.

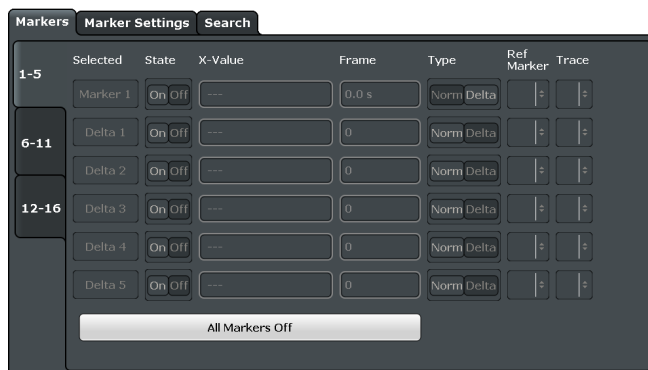

The markers are distributed among 3 tabs for a better overview. By default, the first marker is defined as a normal marker, whereas all others are defined as delta markers with reference to the first marker. All markers are assigned to trace 1, but only the first marker is active.

Selected Marker .....	223
Marker State .....	223
Marker Position X-value .....	223
Frame (Spectrogram only).....	224
Marker Type .....	224
Reference Marker .....	224
Assigning the Marker to a Trace .....	224
Select Marker .....	224
All Marker Off .....	225

#### Selected Marker

Marker name. The marker which is currently selected for editing is highlighted orange.

Remote command:

Marker selected via suffix <m> in remote commands.

#### Marker State

Activates or deactivates the marker in the diagram.

Remote command:

[CALCulate<n>:MARKer<m>\[:STATe\]](#) on page 527

[CALCulate<n>:DELTAmarker<m>\[:STATe\]](#) on page 526

#### Marker Position X-value

Defines the position (x-value) of the marker in the diagram. For normal markers, the absolute position is indicated. For delta markers, the position relative to the reference marker is provided.

Remote command:

[CALCulate<n>:MARKer<m>:X](#) on page 528

[CALCulate<n>:DELTamarker<m>:X](#) on page 526

### Frame (Spectrogram only)

Spectrogram frame the marker is assigned to.

Remote command:

[CALCulate<n>:MARKer<m>:SPECTrogram:FRAMe](#) on page 540

[CALCulate<n>:DELTamarker<m>:SPECTrogram:FRAMe](#) on page 545

### Marker Type

Toggles the marker type.

The type for marker 1 is always "Normal" , the type for delta marker 1 is always "Delta" . These types cannot be changed.

**Note:** If normal marker 1 is the active marker, switching the "Mkr Type" activates an additional delta marker 1. For any other marker, switching the marker type does not activate an additional marker, it only switches the type of the selected marker.

"Normal"            A normal marker indicates the absolute value at the defined position in the diagram.

"Delta"             A delta marker defines the value of the marker relative to the specified reference marker (marker 1 by default).

Remote command:

[CALCulate<n>:MARKer<m>\[:STATe\]](#) on page 527

[CALCulate<n>:DELTamarker<m>\[:STATe\]](#) on page 526

### Reference Marker

Defines a marker as the reference marker which is used to determine relative analysis results (delta marker values).

Remote command:

[CALCulate<n>:DELTamarker<m>:MREF](#) on page 525

### Assigning the Marker to a Trace

The "Trace" setting assigns the selected marker to an active trace. The trace determines which value the marker shows at the marker position. If the marker was previously assigned to a different trace, the marker remains on the previous frequency or time, but indicates the value of the new trace.

If a trace is turned off, the assigned markers and marker functions are also deactivated.

Remote command:

[CALCulate<n>:MARKer<m>:TRACe](#) on page 527

### Select Marker

The "Select Marker" function opens a dialog box to select and activate or deactivate one or more markers quickly.



Remote command:

[CALCulate<n>:MARKer<m>\[:STATe\]](#) on page 527

[CALCulate<n>:DELTamarker<m>\[:STATe\]](#) on page 526

**All Marker Off**

Deactivates all markers in one step.

Remote command:

[CALCulate<n>:MARKer<m>:AOFF](#) on page 527

**9.4.2.2 General Marker Settings**

**Access:** "Overview" > "Analysis" > "Marker" > "Marker Settings"

Some general marker settings allow you to influence the marker behavior for all markers.

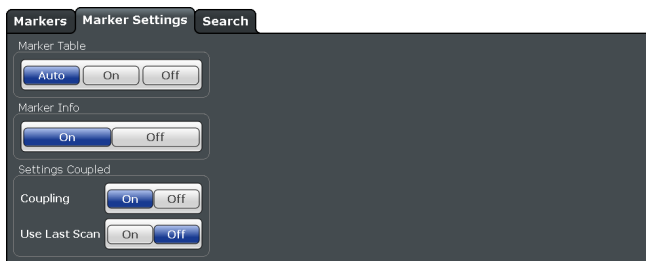

[Marker Table Display](#) .....225

[Marker Info](#) ..... 226

[Settings Coupled](#)..... 226

**Marker Table Display**

Defines how the marker information is displayed.

"On"                    Displays the marker information in a table in a separate area beneath the diagram.

"Off"                    No separate marker table is displayed.

Remote command:

[DISPlay\[:WINDow<n>\]:MTABle](#) on page 530



**Marker Info**

Turns the marker information displayed in the diagram on and off.

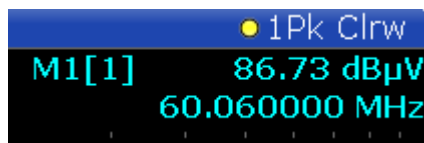

Remote command:

`DISPlay:MINFo[:STATe]` on page 529

**Settings Coupled**

Couples or decouples the receiver settings to the scan range settings when you use [Tune to Marker](#).

When you turn on this feature, the R&S ESW changes the receiver settings according to the scan range the marker frequency is currently in.

In addition, you can select which settings the R&S ESW applies with the "Use Last Scan" feature.

- When you turn it on, the R&S ESW uses the configuration of the last scan.
- When you turn it off, the R&S ESW uses the current configuration of the scan table, if you have changed it since the last scan.  
(If you have not changed anything, the configuration of the last scan is still in effect.)

Remote command:

`CALCulate<n>:MARKer<m>:SCOupled[:STATe]` on page 529

`CALCulate<n>:MARKer<m>:SCOupled:LSCan` on page 528

**9.4.3 Marker Search Settings and Positioning Functions**

Several functions are available to set the marker to a specific position very quickly and easily, or to use the current marker position to define another characteristic value. In order to determine the required marker position, searches may be performed. The search results can be influenced by special settings.

Most marker positioning functions and the search settings are available in the [MKR →] menu.

Search settings are also available via the [Marker] key or in the vertical "Marker Config" tab of the "Analysis" dialog box (horizontal "Search Settings" tab).

For more information on searching for signal peaks see [Chapter 9.4.1.2, "Searching for Signal Peaks"](#), on page 220.

The remote commands required to define these settings are described in [Chapter 13.7.4, "Markers"](#), on page 524.

- [Marker Search](#).....227
- [Marker Search \(Spectrogram\)](#).....228
- [Marker Positioning](#)..... 229

### 9.4.3.1 Marker Search

**Access:** "Overview" > "Analysis" > "Marker" > "Search"

Markers are commonly used to determine peak values, i.e. maximum or minimum values, in the measured signal. Configuration settings allow you to influence the peak search results.

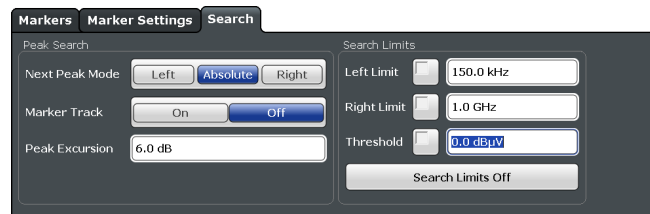

Search Mode for Next Peak .....	227
Peak Excursion .....	227
Search Limits ( Left / Right ).....	227
Search Threshold .....	228
Deactivating All Search Limits .....	228

#### Search Mode for Next Peak

Selects the search mode for the next peak search.

- "Left"                 Determines the next maximum/minimum to the left of the current peak.
- "Absolute"            Determines the next maximum/minimum to either side of the current peak.
- "Right"                Determines the next maximum/minimum to the right of the current peak.

Remote command:

Find a list of remote commands in [Chapter 13.7.4.4, "Marker Positioning"](#), on page 532.

#### Peak Excursion

Defines the minimum level value by which a signal must rise or fall so that it is identified as a maximum or a minimum by the search functions.

Entries from 0 dB to 80 dB are allowed; the resolution is 0.1 dB. The default setting for the peak excursion is 6 dB.

Remote command:

`CALCulate<n>:MARKer<m>:PEXCursion` on page 451

#### Search Limits ( Left / Right )

If activated, limit lines are defined and displayed for the search. Only results within the limited search range are considered.

Remote command:

`CALCulate<n>:MARKer<m>:X:SLIMits[:STATe]` on page 531

`CALCulate<n>:MARKer<m>:X:SLIMits:LEFT` on page 531

`CALCulate<n>:MARKer<m>:X:SLIMits:RIGHT` on page 531

**Search Threshold**

Defines an absolute threshold as an additional condition for the peak search. Only peaks that exceed the threshold are detected.

Remote command:

CALCulate<n>:THReshold on page 532

**Deactivating All Search Limits**

Deactivates the search range limits.

Remote command:

CALCulate<n>:MARKer<m>:X:SLIMits[:STATe] on page 531

CALCulate<n>:THReshold:STATe on page 532

**9.4.3.2 Marker Search (Spectrogram)**

**Access:** "Overview" > "Analysis" > "Marker" > "Search"

These settings are only available for spectrogram displays.

Spectrograms show not only the current measurement results, but also the measurement history. Thus, when searching for peaks, you must define the search settings within a single time frame (x-direction) and within several time frames (y-direction).

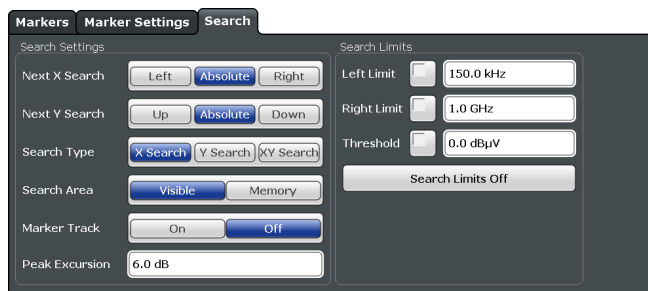

Marker search functions for the spectrogram described elsewhere:

- [Marker Track](#)
- " [Peak Excursion](#) " on page 227
- " [Search Limits \( Left / Right \)](#)" on page 227
- " [Search Threshold](#) " on page 228
- " [Deactivating All Search Limits](#) " on page 228

[Search Mode for Next Peak in X-Direction](#) ..... 228

[Search Mode for Next Peak in Y-Direction](#) ..... 229

[Marker Search Type](#) ..... 229

[Marker Search Area](#) ..... 229

**Search Mode for Next Peak in X-Direction**

Selects the search mode for the next peak search within the currently selected frame.

"Left"                      Determines the next maximum/minimum to the left of the current peak.

"Absolute" Determines the next maximum/minimum to either side of the current peak.

"Right" Determines the next maximum/minimum to the right of the current peak.

Remote command:

Find a list of remote commands in [Chapter 13.7.4.6, "Spectrogram Markers"](#), on page 540.

#### Search Mode for Next Peak in Y-Direction

Selects the search mode for the next peak search within all frames at the current marker position.

"Up" Determines the next maximum/minimum above the current peak (in more recent frames).

"Absolute" Determines the next maximum/minimum above or below the current peak (in all frames).

"Down" Determines the next maximum/minimum below the current peak (in older frames).

Remote command:

Find a list of remote commands in [Chapter 13.7.4.6, "Spectrogram Markers"](#), on page 540.

#### Marker Search Type

Defines the type of search to be performed in the spectrogram.

"X-Search" Searches only within the currently selected frame.

"Y-Search" Searches within all frames but only at the current frequency position.

"XY-Search" Searches in all frames at all positions.

Remote command:

Find a list of remote commands in [Chapter 13.7.4.6, "Spectrogram Markers"](#), on page 540.

#### Marker Search Area

Defines which frames the search is performed in.

"Visible" Only the visible frames are searched.

"Memory" All frames stored in the memory are searched.

Remote command:

[CALCulate<n>:MARKer<m>:SPECTrogram:SARea](#) on page 541

[CALCulate<n>:DELTAmarker<m>:SPECTrogram:SARea](#) on page 545

### 9.4.3.3 Marker Positioning

The following functions set the currently selected marker to the result of a peak search or set other characteristic values to the current marker value. These functions are available as softkeys in the "Marker To" menu, which is displayed when you press the [MKR →] key.

Functions to position markers in the Spectrum application described elsewhere:

- "Settings Coupled" on page 226

Peak Search .....	230
Search Next Peak .....	230
Search Minimum .....	230
Search Next Minimum .....	230

### Peak Search

Sets the selected marker/delta marker to the maximum of the trace. If no marker is active, marker 1 is activated.

For spectrogram displays, define which frame the peak is to be searched in.

Remote command:

`CALCulate<n>:MARKer<m>:MAXimum[:PEAK]` on page 533

`CALCulate<n>:DELTamarker<m>:MAXimum[:PEAK]` on page 536

### Search Next Peak

Sets the selected marker/delta marker to the next (lower) maximum of the assigned trace. If no marker is active, marker 1 is activated.

For spectrogram displays, define which frame the next peak is to be searched in.

Remote command:

`CALCulate<n>:MARKer<m>:MAXimum:NEXT` on page 533

`CALCulate<n>:MARKer<m>:MAXimum:RIGHT` on page 534

`CALCulate<n>:MARKer<m>:MAXimum:LEFT` on page 533

`CALCulate<n>:DELTamarker<m>:MAXimum:NEXT` on page 536

`CALCulate<n>:DELTamarker<m>:MAXimum:RIGHT` on page 536

`CALCulate<n>:DELTamarker<m>:MAXimum:LEFT` on page 535

### Search Minimum

Sets the selected marker/delta marker to the minimum of the trace. If no marker is active, marker 1 is activated.

For spectrogram displays, define which frame the minimum is to be searched in.

Remote command:

`CALCulate<n>:MARKer<m>:MINimum[:PEAK]` on page 534

`CALCulate<n>:DELTamarker<m>:MINimum[:PEAK]` on page 537

### Search Next Minimum

Sets the selected marker/delta marker to the next (higher) minimum of the selected trace. If no marker is active, marker 1 is activated.

For spectrogram displays, define which frame the next minimum is to be searched in.

Remote command:

`CALCulate<n>:MARKer<m>:MINimum:NEXT` on page 534

`CALCulate<n>:MARKer<m>:MINimum:LEFT` on page 534

`CALCulate<n>:MARKer<m>:MINimum:RIGHT` on page 535

`CALCulate<n>:DELTamarker<m>:MINimum:NEXT` on page 537

`CALCulate<n>:DELTamarker<m>:MINimum:LEFT` on page 537

`CALCulate<n>:DELTamarker<m>:MINimum:RIGHT` on page 537

## 9.5 Display and Limit Lines

Display and limit lines help you analyze a measurement trace.

**Access:** "Overview" > "Analysis" > "Lines"

For remote operation, see [Chapter 13.7.5, "Display and Limit Line Configuration"](#), on page 548 .

- [Display Lines](#).....231
- [Limit Lines](#).....233

### 9.5.1 Display Lines

#### 9.5.1.1 Basics on Display Lines

Display lines help you analyze a trace – as do markers. The function of a display line is comparable to that of a ruler that can be shifted on the trace in order to mark absolute values. They are used exclusively to visually mark relevant frequencies or points in time (zero span), as well as constant level values. It is not possible to check automatically whether the points are below or above the marked level values - use limit lines for that task (see [Chapter 9.5.2.1, "Basics on Limit Lines"](#), on page 233).

Two different types of display lines are provided:

- Two horizontal lines: "Horizontal Line 1" and "Horizontal Line 2".  
These lines are continuous horizontal lines across the entire width of a diagram and can be shifted up and down.
- Two vertical lines: "Vertical Line 1" and "Vertical Line 2"  
These lines are continuous vertical lines across the entire height of the diagram and can be shifted left and right.

#### Labels

Each line is identified by one of the following abbreviations in the diagrams:

- H1: "Horizontal Line 1"
- H2: "Horizontal Line 2"
- V1: "Vertical Line 1"
- V2: "Vertical Line 2"

#### 9.5.1.2 Display Line Settings

**Access:** "Overview" > "Analysis" > "Lines" > "Display Lines"

Two vertical and two horizontal lines can be defined in the display.

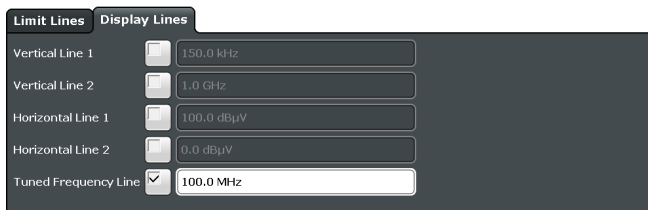

Vertical Line 1 / Vertical Line 2 ..... 232  
 Horizontal Line 1 / Horizontal Line 2 ..... 232  
 Tuned Frequency ..... 232

**Vertical Line 1 / Vertical Line 2**

Activates a vertical display line (V1 or V2) in the diagram at the specified point of the x-axis, depending on the scale of the axis.

Remote command:

- [CALCulate<n>:FLINE<fl>](#) on page 549
- [CALCulate<n>:FLINE<fl>](#) on page 549
- [CALCulate<n>:TLINE<tl>](#) on page 550
- [CALCulate<n>:TLINE<tl>](#) on page 550

**Horizontal Line 1 / Horizontal Line 2**

Activates a horizontal display line (H1 or H2) in the diagram at the specified point of the y-axis

Remote command:

- [CALCulate<n>:DLINE<dl>](#) on page 549
- [CALCulate<n>:DLINE<dl>](#) on page 549

**Tuned Frequency**

Turns a display line that represents the currently selected receiver frequency on and off.

The tuned frequency line is labeled "TF" in the diagram.

Remote command:

- [CALCulate<n>:TFLine:STATE](#) on page 550

**9.5.1.3 Defining Display Lines**

1. Display lines are configured in the "Lines Config" dialog box. To display this dialog box, press the [Lines] key and then "Lines Config" .
2. Select the "Display Lines" tab.
3. To define a vertical line, select "Vertical Line 1" or 2 and enter the x-value at which the line is to be displayed.  
 To define a horizontal line, select "Horizontal Line 1" or 2 and enter the y-value at which the line is to be displayed.

## 9.5.2 Limit Lines

Limit lines allow you to check automatically whether the measured points are below or above specified values.

- [Basics on Limit Lines](#)..... 233
- [Limit Line Settings and Functions](#)..... 237
- [How to Define Limit Lines](#)..... 243
- [Reference: Limit Line File Format](#)..... 246

### 9.5.2.1 Basics on Limit Lines

Limit lines are used to define amplitude curves or spectral distribution boundaries in the result diagram which are not to be exceeded. They indicate, for example, the upper limits for interference radiation or spurious waves which are allowed from a device under test (DUT). When transmitting information in TDMA systems (e.g. GSM), the amplitude of the bursts in a time slot must adhere to a curve that falls within a specified tolerance band. The lower and upper limits may each be specified by a limit line. Then, the amplitude curve can be controlled either visually or automatically for any violations of the upper or lower limits (GO/NOGO test).

The R&S ESW supports limit lines with a maximum of 200 data points. Eight of the limit lines stored in the instrument can be activated simultaneously. The number of limit lines stored in the <instrument> is only limited by the capacity of the storage device used.

Limit line data can also be exported to a file in ASCII (CSV) format for further evaluation in other applications. Limit lines stored in the specified ASCII (CSV) format can also be imported to the R&S ESW for other measurements.

#### Compatibility

Limit lines are compatible with the current measurement settings, if the following applies:

- The x unit of the limit line has to be identical to the current setting.
- The y unit of the limit line has to be identical to the current setting with the exception of dB based units; all dB based units are compatible with each other.

#### Validity

Only limit lines that fulfill the following conditions can be activated:

- Each limit line must consist of a minimum of 2 and a maximum of 200 data points.
- The frequencies/times for each data point must be defined in ascending order; however, for any single frequency or time, two data points may be entered (to define a vertical segment of a limit line).
- Gaps in frequency or time are not allowed. If gaps are desired, two separate limit lines must be defined and then both enabled.
- The entered frequencies or times need not necessarily be selectable in R&S ESW. A limit line may also exceed the specified frequency or time range. The minimum frequency for a data point is -200 GHz, the maximum frequency is 200 GHz. For



the time range representation, negative times may also be entered. The allowed range is -1000 s to +1000 s.

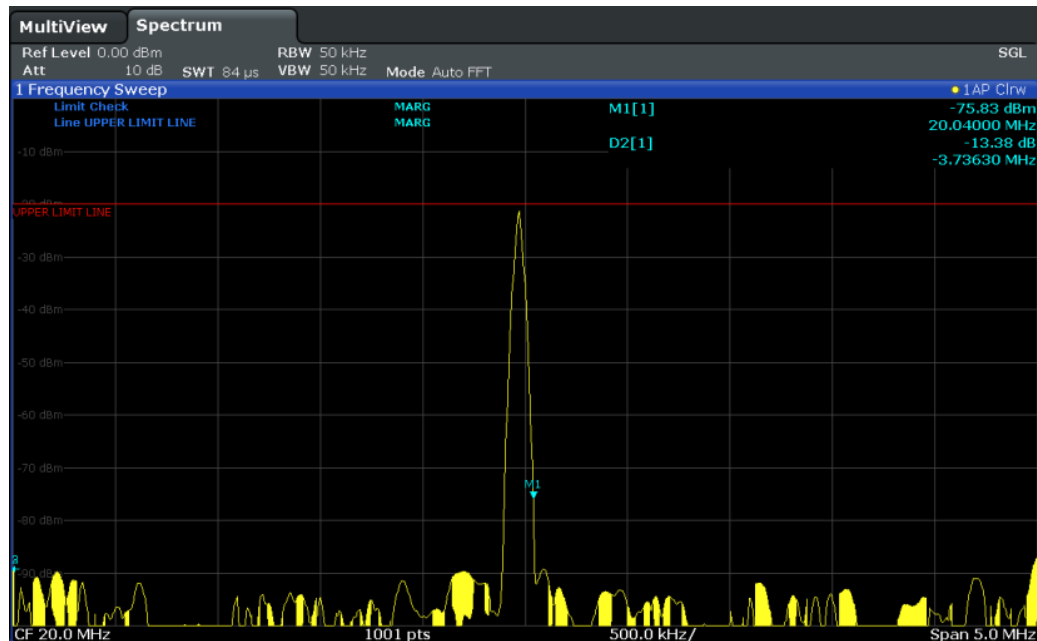

Figure 9-8: Example for an upper limit line

### Limits and Margins

Limit lines define strict values that must not be exceeded by the measured signal. A **margin** is similar to a limit, but less strict and it still belongs to the valid data range. It can be used as a warning that the limit is almost reached. The margin is not indicated by a separate line in the display, but if it is violated, a warning is displayed. Margins are defined as lines with a fixed distance to the limit line.

To check the signal for maximum levels you must define an **upper limit**, whereas to check the signal for minimum levels you must define a **lower limit**.

Limits can be defined relative to the reference level, the beginning of the time scale, or the center frequency, or as absolute values.

Relative scaling is suitable, for example, if masks for bursts are to be defined in zero span, or if masks for modulated signals are required in the frequency domain.

### Thresholds

If the y-axis for the limit line data points uses relative scaling, an additional absolute **threshold** can be defined for the limit check. In this case, both the threshold value and the relative limit line must be exceeded before a violation occurs.

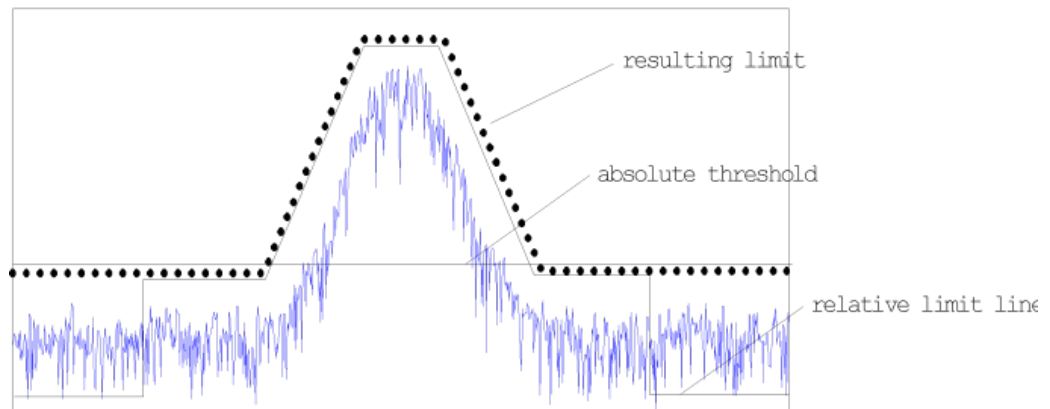

### Offsets and Shifting

A configured limit line can easily be moved vertically or horizontally. Two different methods to do so are available:

- An **offset** moves the entire line in the diagram without editing the configured values or positions of the individual data points. This option is only available if relative scaling is used.  
Thus, a new limit line can be easily generated based upon an existing limit line which has been shifted horizontally or vertically.
- Defining a **shift** width for the values or position of the individual data points changes the line configuration, thus changing the position of the line in the diagram.

### Limit Check Results

A limit check is automatically performed as soon as any of the limit lines is activated ("Visibility" setting). Only the specified "Traces to be Checked" are compared with the active limit lines. The status of the limit check for each limit line is indicated in the diagram. If a violation occurs, the limit check status is set to "MARG" for a margin violation, or to "Fail" for a limit violation.

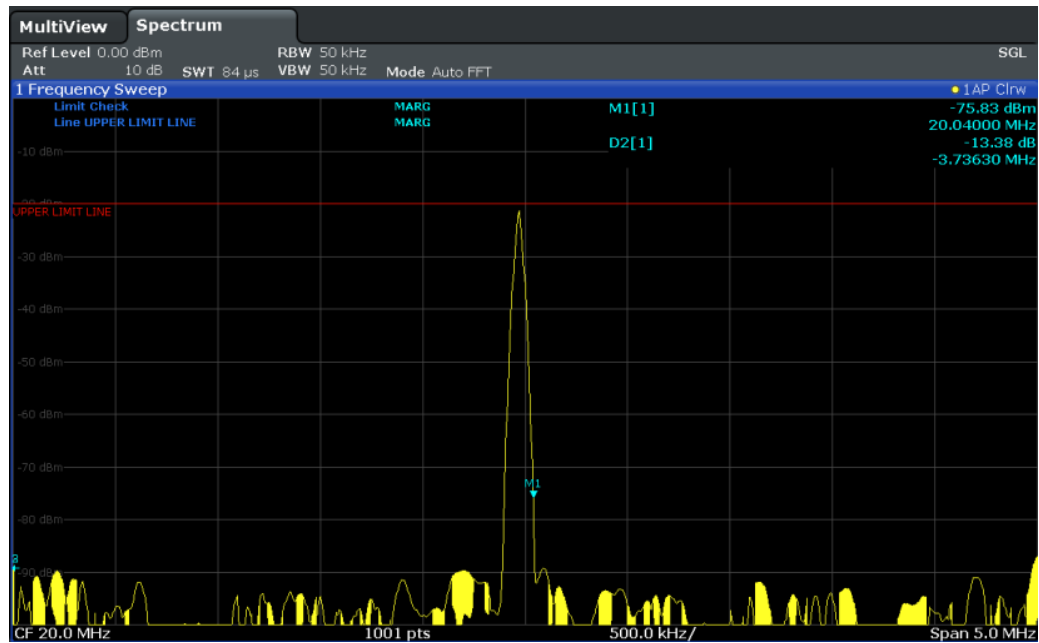

Figure 9-9: Margin violation for limit check



Figure 9-10: Limit violation for limit check



### Storing and Recalling Limit Lines

Limit lines can be stored with the configuration settings so they can be recalled for other measurements at a later time (see [Chapter 10.3, "Storing and Recalling Instrument Settings and Measurement Data"](#), on page 251). Note, however, that any changes made to the limit lines *after* storing the configuration file cannot be restored and will be overwritten by the stored values when the configuration file is recalled. Always remember to store the settings again after changing the limit line values. After recalling measurement settings, the limit line values applied to the measurement may be different to those displayed in the "Limit Lines" dialog box; see ["Saving and recalling transducer and limit line settings"](#) on page 252.

### 9.5.2.2 Limit Line Settings and Functions

**Access:** "Overview" > "Analysis" > "Lines"

Up to 8 limit lines can be displayed simultaneously in the R&S ESW. Many more can be stored on the instrument.



### Stored limit line settings

When storing and recalling limit line settings, consider the information provided in ["Saving and recalling transducer and limit line settings"](#) on page 252.

- [Limit Line Management](#).....237
- [Limit Line Details](#).....240

### Limit Line Management

**Access:** "Overview" > "Analysis" > "Lines" > "Limit Lines"

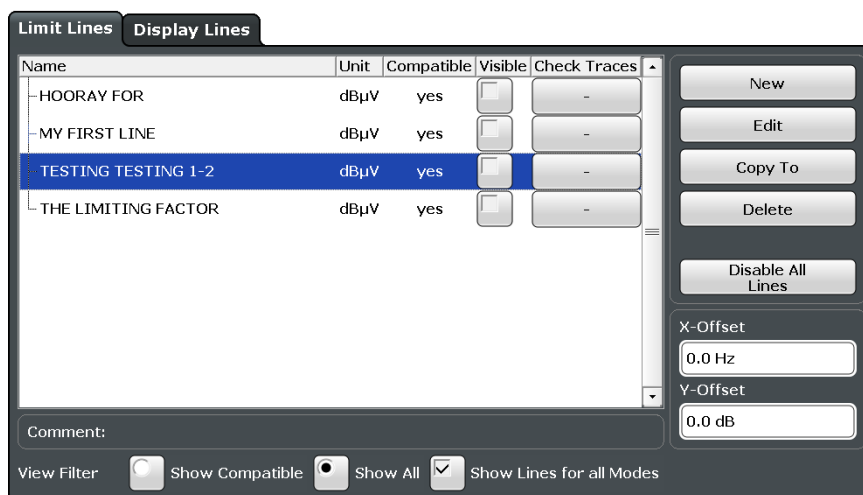

For the limit line overview, the R&S ESW searches for all stored limit lines with the file extension `.LIN` in the `limits` subfolder of the main installation folder. The overview allows you to determine which limit lines are available and can be used for the current measurement.

For details on settings for individual lines see ["Limit Line Details"](#) on page 240.

For more basic information on limit lines see [Chapter 9.5.2.1, "Basics on Limit Lines"](#), on page 233.

Name .....	238
Unit .....	238
Compatibility .....	238
Visibility .....	238
Traces to be Checked .....	238
Comment .....	239
Included Lines in Overview ( View Filter ).....	239
L Show Lines for all Modes .....	239
X-Offset .....	239
Y-Offset .....	239
Create New Line .....	239
Edit Line .....	239
Copy Line .....	239
Delete Line .....	240
Disable All Lines .....	240

### Name

The name of the stored limit line.

### Unit

The unit in which the y-values of the data points of the limit line are defined.

### Compatibility

Indicates whether the limit line definition is compatible with the current measurement settings.

For more information on which conditions a limit line must fulfill to be compatible, see ["Compatibility"](#) on page 233.

### Visibility

Displays or hides the limit line in the diagram. Up to 8 limit lines can be visible at the same time. Inactive limit lines can also be displayed in the diagram.

Remote command:

`CALCulate<n>:LIMit<li>:LOWer:STATe` on page 553

`CALCulate<n>:LIMit<li>:UPPer:STATe` on page 555

`CALCulate<n>:LIMit<li>:ACTive?` on page 552

### Traces to be Checked

Defines which traces are automatically checked for conformance with the limit lines. As soon as a trace to be checked is defined, the assigned limit line is active. One limit line can be activated for several traces simultaneously. If any of the "Traces to be Checked" violate any of the active limit lines, a message is indicated in the diagram.

Remote command:

`CALCulate<n>:LIMit<li>:TRACe<t>:CHECK` on page 554

**Comment**

An optional description of the limit line.

**Included Lines in Overview ( View Filter )**

Defines which of the stored lines are included in the overview.

"Show Compatible"      Only compatible lines  
Whether a line is compatible or not is indicated in the [Compatibility](#) setting.

"Show All"              All stored limit lines with the file extension `.LIN` in the `limits` subfolder of the main installation folder (if not restricted by "Show Lines for all Modes" setting).

**Show Lines for all Modes ← Included Lines in Overview ( View Filter )**

If activated (default), limit lines from all applications are displayed. Otherwise, only lines that were created in the Spectrum application are displayed.

Note that limit lines from some applications may include additional properties that are lost when the limit lines are edited in the Spectrum application. In this case a warning is displayed when you try to store the limit line.

**X-Offset**

Shifts a limit line that has been specified for relative frequencies or times (x-axis) horizontally.

This setting does not have any effect on limit lines that are defined by absolute values for the x-axis.

Remote command:

[CALCulate<n>:LIMit<li>:CONTrol:OFFSet](#) on page 552

**Y-Offset**

Shifts a limit line that has relative values for the y-axis (levels or linear units such as volt) vertically.

This setting does not have any effect on limit lines that are defined by absolute values for the y-axis.

Remote command:

[CALCulate<n>:LIMit<li>:LOWer:OFFSet](#) on page 553

[CALCulate<n>:LIMit<li>:UPPer:OFFSet](#) on page 555

**Create New Line**

Creates a new limit line.

**Edit Line**

Edit an existing limit line configuration.

**Copy Line**

Copy the selected limit line configuration to create a new line.

Remote command:

[CALCulate<n>:LIMit<li>:COPY](#) on page 552

**Delete Line**

Delete the selected limit line configuration.

Remote command:

CALCulate<n>:LIMit<li>:DElete on page 553

**Disable All Lines**

Disable all limit lines in one step.

Remote command:

CALCulate<n>:LIMit<li>:STATe on page 554

**Limit Line Details**

Access: "Overview" > "Analysis" > "Lines" > "Limit Lines" > "New" / "Edit" / "Copy To"

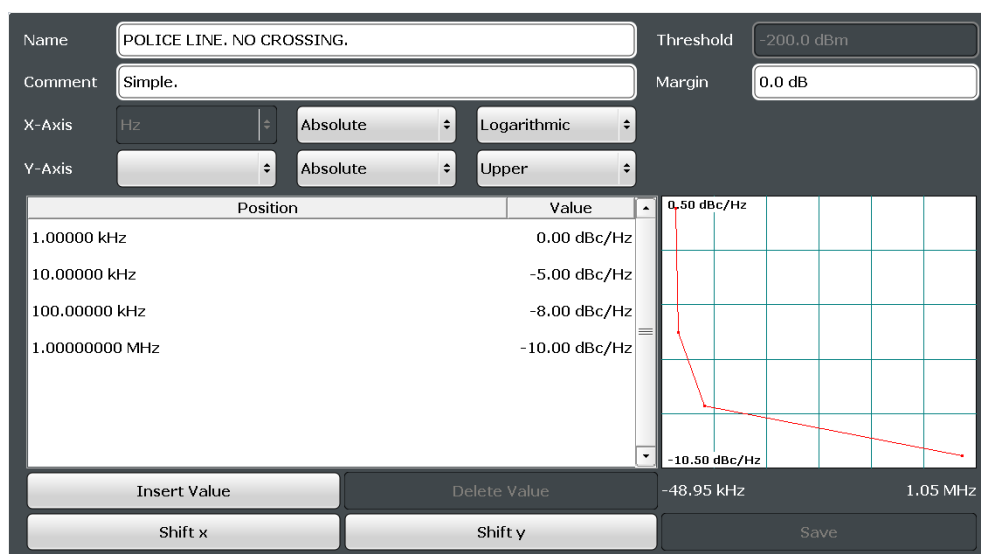

Name .....240

Comment .....241

Threshold .....241

Margin .....241

X-Axis .....241

Y-Axis .....241

Data Points .....242

Insert Value .....242

Delete Value .....242

Shift x .....242

Shift y .....242

Save .....242

Import .....242

Export .....242

**Name**

Defines the limit line name. All names must be compatible with Windows conventions for file names. The limit line data is stored under this name (with a .LIN extension).

Remote command:

[CALCulate<n>:LIMit<li>:NAME](#) on page 561

### Comment

Defines an optional comment for the limit line.

Remote command:

[CALCulate<n>:LIMit<li>:COMMeNt](#) on page 557

### Threshold

Defines an absolute threshold value (only for relative scaling of the y-axis).

Remote command:

[CALCulate<n>:LIMit<li>:LOWer:THReshold](#) on page 560

[CALCulate<n>:LIMit<li>:UPPer:THReshold](#) on page 563

### Margin

Defines a margin for the limit line. The default setting is 0 dB (i.e. no margin).

Remote command:

[CALCulate<n>:LIMit<li>:LOWer:MARGIn](#) on page 559

[CALCulate<n>:LIMit<li>:UPPer:MARGIn](#) on page 562

### X-Axis

Describes the horizontal axis on which the data points of the limit line are defined.

Includes the following settings:

- Unit:
  - "Hz" : for frequency domain
  - "s" : for time domain
- Scaling mode: absolute or relative values  
For relative values, the frequencies are referred to the currently set center frequency. In the time domain, the left boundary of the diagram is used as the reference.
- Scaling: linear or logarithmic

Remote command:

[CALCulate<n>:LIMit<li>:LOWer:MODE](#) on page 559

[CALCulate<n>:LIMit<li>:UPPer:MODE](#) on page 562

[CALCulate<n>:LIMit<li>:CONTRol:DOMain](#) on page 557

[CALCulate<n>:LIMit<li>:CONTRol:SPACIng](#) on page 558

### Y-Axis

Describes the vertical axis on which the data points of the limit line are defined.

Includes the following settings:

- Level unit
- Scaling mode: absolute or relative (dB/%) values  
Relative limit values refer to the reference level.
- Limit type: upper or lower limit; values must stay above the lower limit and below the upper limit to pass the limit check



Remote command:

[CALCulate<n>:LIMit<li>:UNIT](#) on page 561

[CALCulate<n>:LIMit<li>:LOWer:SPACing](#) on page 560

[CALCulate<n>:LIMit<li>:UPPer:SPACing](#) on page 563

### Data Points

Each limit line is defined by a minimum of 2 and a maximum of 200 data points. Each data point is defined by its position (x-axis) and value (y-value). Data points must be defined in ascending order. The same position can have two different values.

Remote command:

[CALCulate<n>:LIMit<li>:CONTRol\[:DATA\]](#) on page 557

[CALCulate<n>:LIMit<li>:LOWer\[:DATA\]](#) on page 559

[CALCulate<n>:LIMit<li>:UPPer\[:DATA\]](#) on page 561

### Insert Value

Inserts a data point in the limit line above the selected one in the "Edit Limit Line" dialog box.

### Delete Value

Deletes the selected data point in the "Edit Limit Line" dialog box.

### Shift x

Shifts the x-value of each data point horizontally by the defined shift width (as opposed to an additive offset defined for the entire limit line, see "X-Offset" on page 239).

Remote command:

[CALCulate<n>:LIMit<li>:CONTRol:SHIFt](#) on page 558

### Shift y

Shifts the y-value of each data point vertically by the defined shift width (as opposed to an additive offset defined for the entire limit line, see "Y-Offset" on page 239).

Remote command:

[CALCulate<n>:LIMit<li>:LOWer:SHIFt](#) on page 560

[CALCulate<n>:LIMit<li>:UPPer:SHIFt](#) on page 562

### Save

Saves the currently edited limit line under the name defined in the "Name" field.

### Import

Opens a file selection dialog box and loads the limit line from the selected file in .CSV format.

Note that a valid import file must contain a minimum of required information for the R&S ESW.

Remote command:

[MMEMory:LOAD<n>:LIMit](#) on page 556

### Export

Opens a file selection dialog box and stores the currently displayed limit line to the defined file in .CSV format.

The limit line can be imported again later by the R&S ESW for use in other measurements.

Remote command:

`MMEMory:STORe<n>:LIMit` on page 556

### 9.5.2.3 How to Define Limit Lines

**Access:** "Overview" > "Analysis" > "Lines" > "Limit Lines"

The following tasks are described here:

- "How to find compatible limit lines" on page 243
- "How to activate and deactivate a limit check" on page 243
- "How to edit existing limit lines" on page 243
- "How to copy an existing limit line" on page 244
- "How to delete an existing limit line" on page 244
- "How to configure a new limit line" on page 244
- "How to move the limit line vertically or horizontally" on page 245

#### How to find compatible limit lines

- ▶ In the "Line Config" dialog box, select the "View Filter" option: "Show Compatible". All stored limit lines with the file extension `.LIN` in the `limits` subfolder of the main installation folder of the instrument that are compatible to the current measurement settings are displayed in the overview.

#### How to activate and deactivate a limit check

A limit check is automatically performed as soon as any of the limit lines is activated.

1. To activate a limit check:  
Select the "Check Traces" setting for a limit line in the overview and select the trace numbers to be included in the limit check. One limit line can be assigned to several traces.  
The specified traces to be checked are compared with the active limit lines. The status of the limit check is indicated in the diagram.
2. To deactivate a limit line, deactivate all "Traces to be Checked" for it.  
To deactivate all limit lines at once, select the "Disable All Lines" button.  
The limit checks for the deactivated limit lines are stopped and the results are removed from the display.

#### How to edit existing limit lines

Existing limit line configurations can be edited.

1. In the "Line Config" dialog box, select the limit line.
2. Select the "Edit" button.

3. Edit the line configuration as described in ["How to configure a new limit line"](#) on page 244.
4. Save the new configuration by selecting the "Save" button.  
If the limit line is active, the edited limit line is displayed in the diagram.

#### How to copy an existing limit line

1. In the dialog box, select the limit line.
2. Select the "Line Config" "Copy To" button.
3. Define a new name to create a new limit with the same configuration as the source line.
4. Edit the line configuration as described in ["How to configure a new limit line"](#) on page 244.
5. Save the new configuration by selecting the "Save" button.  
The new limit line is displayed in the overview and can be activated.

#### How to delete an existing limit line

1. In the "Line Config" dialog box, select the limit line.
2. Select the "Delete" button.
3. Confirm the message.  
The limit line and the results of the limit check are deleted.

#### How to configure a new limit line

1. In the "Line Config" dialog box, select the "New" button.  
The "Edit Limit Line" dialog box is displayed. The current line configuration is displayed in the preview area of the dialog box. The preview is updated after each change to the configuration.
2. Define a "Name" and, optionally, a "Comment" for the new limit line.
3. Define the x-axis configuration:
  - Time domain or frequency domain
  - Absolute or relative limits
  - Linear or logarithmic scaling
4. Define the y-axis configuration:
  - Level unit
  - Absolute or relative limits
  - Upper or lower limit line
5. Define the data points: minimum 2, maximum 200:
  - a) Select "Insert Value" .
  - b) Define the x-value ( "Position" ) and y-value ( "Value" ) of the first data point.

- c) Select "Insert Value" again and define the second data point.
  - d) Repeat this to insert all other data points.  
To insert a data point before an existing one, select the data point and then "Insert Value" .  
To insert a new data point at the end of the list, move the focus to the line after the last entry and then select "Insert Value" .  
To delete a data point, select the entry and then "Delete Value" .
6. Check the current line configuration in the preview area of the dialog box. If necessary, correct individual data points or add or delete some.  
If necessary, shift the entire line vertically or horizontally by selecting the "Shift x" or "Shift y" button and defining the shift width.
  7. Optionally, define a "Margin" at a fixed distance to the limit line.  
The margin must be within the valid value range and is not displayed in the diagram or preview area.
  8. Optionally, if the y-axis uses relative scaling, define an absolute "Threshold" as an additional criteria for a violation.
  9. Save the new configuration by selecting the "Save" button.  
The new limit line is displayed in the overview and can be activated.

#### **How to move the limit line vertically or horizontally**

A configured limit line can easily be moved vertically or horizontally. Thus, a new limit line can be easily generated based upon an existing limit line which has been shifted horizontally.

1. In the "Line Config" dialog box, select the limit line.
2. To shift the complete limit line parallel in the horizontal direction, select the "X-Offset" button and enter an offset value.  
To shift the complete limit line parallel in the vertical direction, select the "Y-Offset" button and enter an offset value.
3. To shift the individual data points of a limit line by a fixed value (all at once):
  - a) Select the "Edit" button.
  - b) In the "Edit Limit Line" dialog box, select the "Shift x" or "Shift y" button and define the shift width.
  - c) Save the shifted data points by selecting the "Save" button.

If activated, the limit line is shifted in the diagram.

#### **How to export a limit line**

Limit line configurations can be stored to an ASCII file for evaluation in other programs or to be imported later for other measurements.

1. In the "Line Config" dialog box, select the limit line.
2. Select the "New" or "Edit" button.

3. Define the limit line as described in ["How to configure a new limit line"](#) on page 244.
4. Select "Export" to save the configuration to a file.  
You are asked whether you would like to save the configuration internally on the R&S ESW first.
5. Select a file name and location for the limit line.
6. Select the decimal separator to be used in the file.
7. Select "Save" .  
The limit line is stored to a file with the specified name and the extension .CSV.  
For details on the file format see [Chapter 9.5.2.4, "Reference: Limit Line File Format"](#), on page 246.

#### How to import a limit line

Limit line configurations that are stored in an ASCII file and contain a minimum of required data can be imported to the R&S ESW.

For details on the required file format see [Chapter 9.5.2.4, "Reference: Limit Line File Format"](#), on page 246.

1. In the "Line Config" dialog box, select the limit line.
2. Select the "New" or "Edit" button.
3. Select "Import" to load a limit line from a file.  
You are asked whether you would like to save the current configuration on the R&S ESW first.
4. Select the file name of the limit line.
5. Select the decimal separator that was used in the file.
6. Select "Select" .  
The limit line is loaded from the specified file and displayed in the "Edit Limit Line" dialog box.
7. Activate the limit line as described in ["How to activate and deactivate a limit check"](#) on page 243.

#### 9.5.2.4 Reference: Limit Line File Format

Limit line data can be exported to a file in ASCII (CSV) format for further evaluation in other applications. Limit lines stored in the specified ASCII (CSV) format can also be imported to the R&S ESW for other measurements (see ["How to import a limit line"](#) on page 246). This reference describes in detail the format of the export/import files for limit lines. Note that the **bold** data is **mandatory**, all other data is optional.

Different language versions of evaluation programs may require a different handling of the decimal point. Thus, you can define the decimal separator to be used (see "[Decimal Separator](#)" on page 204).

**Table 9-4: ASCII file format for limit line files**

File contents	Description
<b>Header data</b>	
sep=;	Separator for individual values (required by Microsoft Excel, for example)
Type;RS_LimitLineDefinition;	Type of data
FileFormatVersion;1.00;	File format version
Date;01.Oct 2006;	Date of data set storage
OptionID;SpectrumAnalyzer	Application the limit line was created for
Name;RELFREQ1	Limit line name
Comment;Defines the upper limit line	Description of limit line
XAxisScaling;LINEAR	Scaling of x-axis linear (LIN) or logarithmic (LOG)
XAxisUnit;FREQ_HZ	Unit of x values
XAxisScaleMode;ABSOLUTE	Scaling of x-axis (absolute or relative)
YAxisUnit;LEVEL_DB	Unit of y values
YAxisScaleMode;ABSOLUTE	Scaling of y-axis (absolute or relative)
Mode;UPPER	Type of limit line (upper, lower)
ThresholdUnit;LEVEL_DBM	Unit of threshold value
ThresholdValue;-200	Threshold value
MarginValue;0	Margin value
NoOfPoints;5	Number of points the line is defined by
<b>Data section for individual data points</b>	
-4500000000;-50	<b>x- and y-values of each data point defining the line</b>
-2000000000;-30	
-1000000000;0	
0;-30	
2500000000;-50	

## 10 Data Management

The R&S ESW allows you to store and load instrument settings, as well as import and export measurement data for analysis later. Finally, you can store or print the measurement results displayed on the screen.

General storage and import/export functions are available via the toolbar. Some special storage functions are (also) available via softkeys or dialog boxes in the corresponding menus, for example trace data export.

- [Restoring the Default Instrument Configuration \(Preset\)](#)..... 248
- [Protecting Data Using the Secure User Mode](#)..... 249
- [Storing and Recalling Instrument Settings and Measurement Data](#)..... 251
- [Import/Export Functions](#)..... 261
- [I/Q Data Import and Export](#)..... 262
- [Creating Screenshots of Current Measurement Results and Settings](#)..... 270
- [Working with Test Reports](#)..... 282

### 10.1 Restoring the Default Instrument Configuration (Preset)

When delivered, the R&S ESW has a default configuration. You can restore this defined initial state at any time as a known starting point for measurements. This is often recommendable as a first step in troubleshooting when unusual measurement results arise.



#### Factory default configuration

The factory default configuration is selected such that the RF input is always protected against overload, provided that the applied signal levels are in the allowed range for the instrument.

Alternatively to the factory default settings, you can define user-specific recall settings to be restored after a preset or reboot, see "[To recall settings automatically after preset or reboot](#)" on page 261.

#### To restore the default instrument configuration for all channels at once

- ▶ Press the [PRESET] key.



After you use the [PRESET] function, the history of previous actions is deleted, i.e. any actions performed previously cannot be undone or redone using the [UNDO/REDO] keys.

#### Remote command:

\*RST or SYSTem:PRESet

### To restore the default configuration for a single channel

The default measurement settings can also be reset for an individual channel only, rather than resetting the entire instrument.

- ▶ In the "Overview" , select the "Preset Channel" button.

The factory default settings are restored to the current channel. Note that a user-defined recall settings file is **NOT** restored.

#### Remote command:

`SYSTem:PRESet:CHANnel [:EXEC]` on page 582

## 10.2 Protecting Data Using the Secure User Mode

During normal operation, the R&S ESW uses a solid-state drive to store its operating system, instrument firmware, instrument self-alignment data, and any user data created during operation. If necessary, the solid-state drive can be removed from the R&S ESW and locked in a secure place to protect any classified data it may contain.

### Redirecting storage to volatile memory

Alternatively, to avoid storing any sensitive data on the R&S ESW permanently, the *secure user mode* was introduced (option R&S ESW-K33). In secure user mode the instrument's solid-state drive is write-protected so that no information can be written to memory permanently. Data that the R&S ESW normally stores on the solid-state drive is redirected to volatile memory instead, which remains available only until the instrument is switched off. This data includes:

- Windows operating system files
- Firmware shutdown files containing information on last instrument state
- Self-alignment data
- General instrument settings such as the IP address
- Measurement settings
- User data created during operation (see also [Table 10-1](#))
- Any data created by other applications installed on the R&S ESW, for example text editors (Notepad), the Clipboard, drawing tools, etc.

Users can access data that is stored in volatile memory just as in normal operation. However, when the instrument's power is switched off, all data in this memory is cleared. Thus, in secure user mode, the instrument always starts in a defined, fixed state when switched on.

To store data such as measurement results permanently, it must be stored to an external storage device, such as a memory stick.





### Limited storage space

The volatile memory used to store data in secure user mode is restricted to 256 MB. Thus, a "Memory full" error can occur although the hard disk indicates that storage space is still available.

### Storing required data permanently

Any data that is to be available for subsequent sessions with the R&S ESW must be stored on the instrument permanently, *before activating the secure user mode*. This includes predefined instrument settings, transducer factors and self-alignment data.



### Self-alignment data

Note that self-alignment data becomes invalid with time and due to temperature changes. Therefore, to achieve optimal accuracy, it may be preferable to perform a new self-alignment at the start of each new session on the R&S ESW.

### Restricted operation

Since permanent storage is not possible, the following functions are not available in secure user mode:

- Firmware update
- Activating a new option key

Furthermore, since the "SecureUser" used in secure user mode does not have administrator rights, **administrative tasks** such as LAN configuration and some general instrument settings are not available. Refer to the description of the basic instrument setup ([SETUP] menu) to find out which functions are affected.

### Activating and deactivating secure user mode

Only a user with administrator rights can activate the secure user mode. Once activated, a restart is required. The special user "SecureUser" is then logged on to the R&S ESW automatically using the automatic login function. While the secure user mode is active, a message is displayed in the status bar at the bottom of the screen.



### Secure Passwords

By default, the initial password for both the administrator account ("Instrument") and the "SecureUser" account is "894129". When the secure user mode is activated the first time after installation, you are prompted to change the passwords for all user accounts to improve system security. Although it is possible to continue without changing the passwords, it is strongly recommended that you do so.

You can change the password in Microsoft Windows for any user at any time via "Start > Control Panel > User Accounts".

To deactivate the secure user mode, the "SecureUser" must log off and the "Instrument" user (administrator) must log on.



### Switching users when using the automatic login function

In the "Start" menu, select the arrow next to the "Shut down" button and then "Log off". The "Login" dialog box is displayed, in which you can enter the different user account name and password.

The secure user mode setting and automatic login is automatically deactivated when the "Instrument" user logs on. The "SecureUser" is no longer available.

For administrators ("Instrument" user), the secure user mode setting is available in the general system configuration settings (see "[SecureUser Mode](#)" on page 328).

### Remote control

Initially after installation of the R&S ESW-K33 option, secure user mode must be enabled manually once before remote control is possible.

(See `SYSTEM:SECURITY[:STATe].`)

This is necessary to prompt for a change of passwords.

## 10.3 Storing and Recalling Instrument Settings and Measurement Data



**Access:** "Save" / "Open" icon in the toolbar



Possibly you would like to restore or repeat a measurement you performed under specific conditions on the instrument. Or you want to evaluate imported data in another application on the R&S ESW and would like to restore the measurement settings applied during measurement. In these cases, you can store and recall instrument and measurement settings, and possibly other related measurement data.

Two different methods are available for managing instrument settings:

- Quick Save/Quick Recall - a defined set of instrument settings or channels are stored or recalled quickly in just one step
- Configurable Save/Recall - a user-defined set of instrument settings or channels are stored to a definable storage location



### Restrictions when recalling measurement settings

When recalling a saved configuration file, the following restrictions apply:

- The R&S ESW must support the frequency range defined in the configuration file.
- Configuration files created on a R&S ESW with certain options in use do not work on an R&S ESW without these options.
- Files created with newer firmware versions may not work with a previous version.
- Files created on an instrument other than the R&S ESW do not work on the R&S ESW.



**Saving instrument settings in secure user mode**

Be sure to store instrument settings that you require beyond the current session before **SecureUser Mode** is enabled; see [Chapter 2.7, "Protecting Data Using the Secure User Mode"](#), on page 37.

Settings that are saved via QuickSave in secure user mode are only available during the current session. As soon as the power is switched off on the R&S ESW, the data is cleared.



**Saving and recalling transducer and limit line settings**

If a transducer factors or limit lines file was in use when the save set was stored (with the save item "Current Settings" only) the R&S ESW assumes that these transducer factors or limit lines values should remain valid after every recall of that save set. Thus, even if the transducer factors or limit lines file is changed and the original save set file is recalled later, the *originally stored* transducer factors or limit lines values are recalled and applied to the measurement. In the "Edit" transducer factors or limit lines dialog box, however, the *changed* transducer factors or limit lines file values are displayed, as no updated transducer factors or limit lines file was loaded.

The same applies to limit line settings.

The same applies to integrated measurements' weighting filter.

If you want to apply the changed transducer values after recalling the save set, you must force the application to reload the transducer file. To do so, simply open the "Edit Transducer" dialog box (see [Chapter 11.3.2, "Working with Transducers"](#), on page 307) and toggle the "X-Axis" option from "Lin" to "log" and back. Due to that change, the transducer file is automatically reloaded, and the changed transducer values are applied to the current measurement. Now you can create a new save set with the updated transducer values.

Similarly, if you want to apply the changed limit values after recalling the save set, you must force the application to reload the limit file. To do so, simply open the "Edit Limit Line" dialog box (see [Chapter 9.5.2.2, "Limit Line Settings and Functions"](#), on page 237) and toggle the "Y-Axis" unit. Due to that change, the limit line file is automatically reloaded, and the changed limit values are applied to the current measurement. Now a new save set with the updated limit values can be created.

- [Quick Save/Quick Recall](#).....252
- [Configurable Storage and Recall](#)..... 254
- [How to Save and Load Instrument Settings](#).....259

**10.3.1 Quick Save/Quick Recall**

The Quick Save and Quick Recall functions allow you to store instrument settings or channels very easily and quickly in one step. Up to ten different sets of settings can be stored to or recalled from "save sets". Each save set is identified by its storage date and type (instrument or specific "Channel" ) in the display. The save sets are stored in the C:\R\_S\Instr\User\QuickSave directory, in files named QuickSave1.dfl to QuickSave10.dfl. The storage filenames and locations cannot be changed. Only

the current measurement settings are stored, not any additional data such as traces, limit line or transducer files (see [Chapter 10.3.2.1, "Stored Data Types"](#), on page 254).



**Saving instrument settings in secure user mode**

Settings that are saved via Quick Save in secure user mode are stored to the SDRAM, and are only available during the current session. As soon as the power is switched off on the R&S ESW, the data is cleared (see [Chapter 2.7, "Protecting Data Using the Secure User Mode"](#), on page 37).

During recall, save sets of type "Instrument" replace the settings of the entire instrument. All other save sets start a new channel with the stored settings.



If a channel with the same name as the "Channel" to be restored is already active, the name for the new channel is extended by a consecutive number:



**10.3.1.1 Quick Save / Quick Recall Settings**



**Access:** "Save" / "Open" icon in the toolbar > "Quick Save" / "Quick Recall"



Both dialog boxes are very similar and closely related.

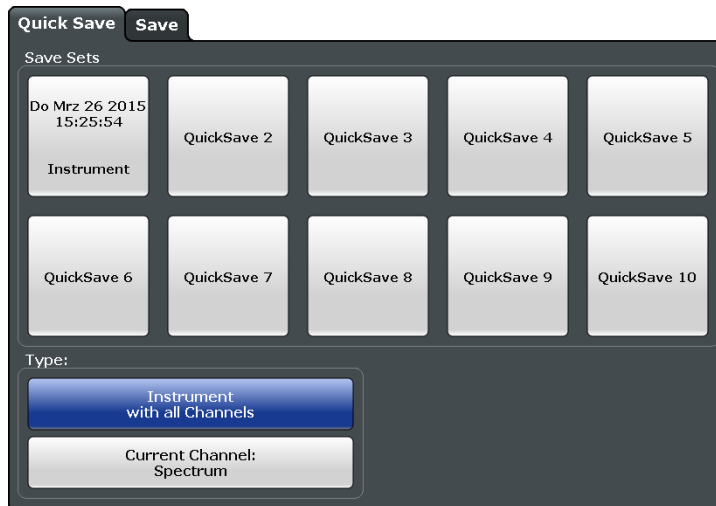

[QuickSave 1 / ... / QuickSave 10](#) ..... 253  
[Storage Type \(Save only\)](#) ..... 254  
[Recall](#) ..... 254

**QuickSave 1 / ... / QuickSave 10**

Selects one of the save sets to store the current settings in or to be recalled. At the time of storage, the "QuickSave 1 / ... / QuickSave 10" placeholder is replaced by a label indicating the storage date and time and the storage type.

During recall, save sets of type "Instrument" replace the settings of the entire instrument. All other save sets start a new channel with the stored settings.

**Note:** Saving instrument settings in secure user mode.

Settings that are saved via Quick Save in secure user mode are only available during the current session. As soon as the power is switched off on the R&S ESW, the data is cleared (see [Chapter 2.7, "Protecting Data Using the Secure User Mode"](#), on page 37).

### Storage Type (Save only)

Defines which type of settings are stored in the save set.

"Instrument with all Channels" The instrument settings for all currently active "Channel" s are stored.

"Current Channel" Only the instrument settings for the currently selected measurement "Channel" s are stored.

### Recall

Restores the instrument settings as saved in the selected settings file. If the settings file contains settings for a specific "Channel" only, a new channel with the stored settings is activated, otherwise all "Channel" s and instrument settings are overwritten with the stored settings.

**Note:** After you use the "Recall" function, the history of previous actions is deleted, i.e. any actions performed previously cannot be undone or redone using the [UNDO/REDO] keys.

**Note:** If a channel with the same name as the "Channel" to be restored (in a new "Channel" ) is already active, the name for the new channel is extended by a consecutive number:



In remote commands, you must append this number to the channel name, as well.

Remote command:

[MMEMory:LOAD:STATe](#) on page 579

## 10.3.2 Configurable Storage and Recall

The more sophisticated storage and recall functions allow you to define which settings are stored, and where the settings file is stored to. Any settings file can be selected for recall.

- [Stored Data Types](#)..... 254
- [Storage Location and Filename](#)..... 255
- [Save and Recall Dialog Boxes](#).....255
- [Startup Recall Settings](#).....258

### 10.3.2.1 Stored Data Types

The following types of data can be stored to and loaded from files via the "Save" dialog box on the R&S ESW:

**Table 10-1: Items that can be stored to files**

Item	Description
Current Settings	Current instrument and measurement settings.
All Transducers	All transducer factor <i>files</i> . (Note: Restoring a saveset overwrites transducer factor files on the hard disk that have the same name as those in the saveset. For more information, see <a href="#">"Saving and recalling transducer and limit line settings"</a> on page 252.)
All Traces	All active traces.
All Limit Lines	All limit line <i>files</i> .
Spectrograms	Spectrogram trace data (only available if spectrogram display is currently active).
Peak List	Information of the peak list.

### 10.3.2.2 Storage Location and Filename

The data is stored on the internal flash disk or, if selected, on a memory stick or network drive. The operating system, firmware and stored instrument settings are located on drive C.



#### Saving instrument settings in secure user mode

In secure user mode all data is stored to the SDRAM, and is only available during the current session. As soon as the power is switched off on the R&S ESW, the data is cleared (see [Chapter 2.7, "Protecting Data Using the Secure User Mode"](#), on page 37). Other storage locations cannot be selected in this mode.

The storage location and filename are selected in a file selection dialog box which is displayed when you perform a storage function.

By default, the name of a settings file consists of a base name followed by an underscore and three numbers, e.g. `limit_lines_005`. In the example, the base name is `limit_lines`. The base name can contain characters, numbers and underscores. The file extension `df1` is added automatically. The default folder for settings files is `C:\R_S\Instr\User`.



#### File name restrictions

File names must be compatible with the Windows conventions for file names. In particular, they must not contain special characters such as `:", "*", "?"`.

### 10.3.2.3 Save and Recall Dialog Boxes



**Access:** "Save" / "Open" icon in the toolbar > "Save" / "Recall"



Both dialog boxes are very similar and closely related.

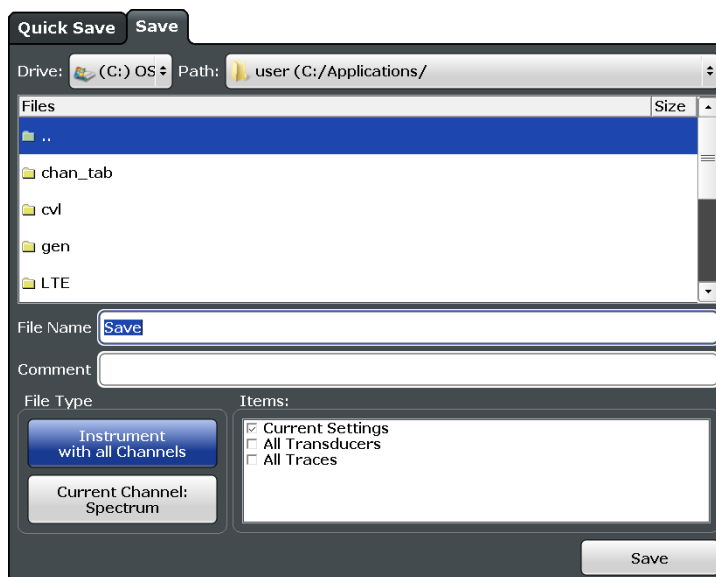

Selecting Storage Location - Drive/ Path/ Files.....256

File Name .....256

Comment .....256

File Type .....257

Items: .....257

Save File .....257

Recall in New Channel / Recall in Current Channel .....257

**Selecting Storage Location - Drive/ Path/ Files**

Select the storage location of the file on the <instrument> or an external drive.

**Note:** Saving instrument settings in secure user mode.

In secure user mode, settings that are stored on the instrument are stored to volatile memory, which is restricted to 256 MB. Thus, a "memory limit reached" error can occur although the hard disk indicates that storage space is still available.

To store data permanently, select an external storage location such as a USB memory device.

For details, see [Chapter 2.7, "Protecting Data Using the Secure User Mode"](#), on page 37.

Remote command:

[MMEMory:CATalog?](#) on page 569

**File Name**

Contains the name of the data file without the path or extension.

File names must be compatible with the Windows conventions for file names. In particular, they must not contain special characters such as ":", "\*", "?".

For details on the filename and location, see [Chapter 10.3.2.2, "Storage Location and Filename"](#), on page 255.

**Comment**

An optional description for the data file. A maximum of 60 characters can be displayed.

Remote command:

[MMEMory:COMMeNt](#) on page 571

### File Type

Determines whether the global instrument settings with all "Channel" s are stored or recalled, or the current "Channel" settings only.

### Items:

Defines which data and settings are stored or are recalled. Depending on the "File Type" , either channels only, or global settings are available. Which items are available also depends on the installed options (see also [Chapter 10.3.2.1, "Stored Data Types"](#), on page 254).

Depending on the application, items may or may not be available. For example, saving spectrogram data is only possible in applications that feature a spectrogram.

Remote command:

[MMEMory:SELEct\[:ITEM\]:ALL](#) on page 576

[MMEMory:SELEct\[:ITEM\]:DEFault](#) on page 576

[MMEMory:SELEct\[:ITEM\]:NONE](#) on page 577

[MMEMory:SELEct\[:ITEM\]:HWSettings](#) on page 576

[MMEMory:SELEct\[:ITEM\]:LINES:ALL](#) on page 577

[MMEMory:SELEct\[:ITEM\]:SGRam](#) on page 577

[MMEMory:SELEct\[:ITEM\]:TRACe\[:ACTive\]](#) on page 578

[MMEMory:SELEct\[:ITEM\]:TRANsducer:ALL](#) on page 578

### Save File

Saves the settings file with the defined filename.

**Note:** Secure user mode. In secure user mode, settings that are stored on the instrument are stored to volatile memory, which is restricted to 256 MB. Thus, a "memory limit reached" error can occur although the hard disk indicates that storage space is still available.

For details, see [Chapter 2.7, "Protecting Data Using the Secure User Mode"](#), on page 37.

Remote command:

[MMEMory:STORe<n>:STATe](#) on page 580

[MMEMory:STORe<n>:STATe:NEXT](#) on page 581

### Recall in New Channel / Recall in Current Channel

Restores the instrument settings as saved in the selected settings file. If the settings file contains settings for a specific "Channel" only, select "Recall in New Channel" to activate a new channel with the stored settings. Select "Recall in Current Channel" to replace the current "Channel" settings.

**Note:** After you use the "Recall" function, the history of previous actions is deleted, i.e. any actions performed previously cannot be undone or redone using the [UNDO/REDO] keys.

**Note:** If a channel with the same name as the "Channel" to be restored (in a new "Channel" ) is already active, the name for the new channel is extended by a consecutive number:





In remote commands, you must append this number to the channel name, as well.

Remote command:

`MMEMory:LOAD:STATe` on page 579

### 10.3.2.4 Startup Recall Settings



**Access:** "Open" icon in the toolbar > "Startup Recall"

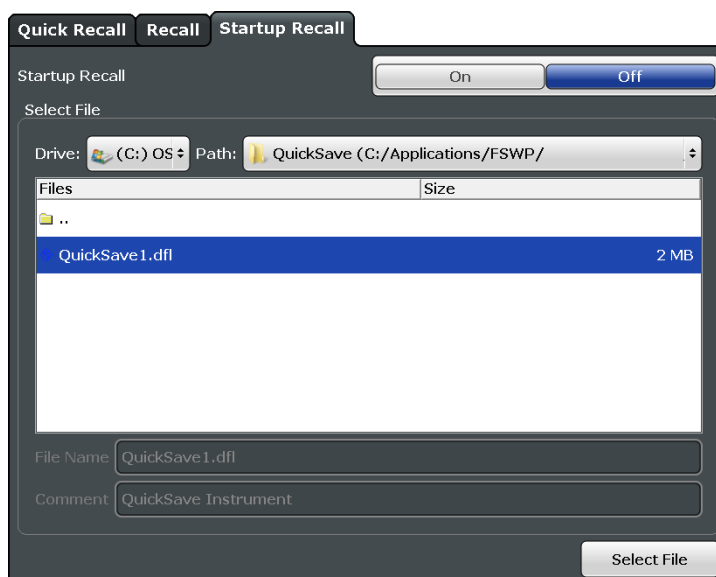

Startup Recall .....	258
Selecting Storage Location - Drive/ Path/ Files.....	258
File Name .....	259
Comment .....	259

#### Startup Recall

Activates or deactivates the startup recall function. If activated, the settings stored in the selected file are loaded each time the instrument is started or preset. If deactivated, the default settings are loaded.

Note that only *instrument* settings files can be selected for the startup recall function, not "Channel" files.

Remote command:

`MMEMory:LOAD:AUTO` on page 579

#### Selecting Storage Location - Drive/ Path/ Files

Select the storage location of the file on the <instrument> or an external drive.

**Note:** Saving instrument settings in secure user mode.

In secure user mode, settings that are stored on the instrument are stored to volatile memory, which is restricted to 256 MB. Thus, a "memory limit reached" error can occur although the hard disk indicates that storage space is still available.

To store data permanently, select an external storage location such as a USB memory device.

For details, see [Chapter 2.7, "Protecting Data Using the Secure User Mode"](#), on page 37.

Remote command:

`MMEMemory:CATalog?` on page 569

#### File Name

Contains the name of the data file without the path or extension.

File names must be compatible with the Windows conventions for file names. In particular, they must not contain special characters such as ":", "\*", "?".

For details on the filename and location, see [Chapter 10.3.2.2, "Storage Location and Filename"](#), on page 255.

#### Comment

An optional description for the data file. A maximum of 60 characters can be displayed.

Remote command:

`MMEMemory:COMMent` on page 571

### 10.3.3 How to Save and Load Instrument Settings

Instrument settings can be saved to a file and loaded again later, so that you can repeat the measurement with the same settings. Optionally, user-defined measurement settings can automatically be restored each time you start or preset the instrument.

#### To save and recall instrument settings using the Quick Save function



1. Select the "Save" icon from the toolbar.
2. Select whether the instrument settings for **all** "Channel" s are stored, or only those for the **current** "Channel" .
3. Select one of the save sets in which the settings are stored ( "QuickSaveX" ).

The selected settings are stored to the file

`C:\R_S\Instr\UserQuickSave\QuickSaveX.dfl.`

**Note:** If you make any changes to the settings *after* storing the configuration file, remember to save the settings again. Otherwise those settings cannot be restored and will be overwritten by the stored values when the configuration file is recalled.



4. To restore the settings, select the "Open" icon from the toolbar.
5. Select the save set in which the settings were stored ( "QuickSaveX" ).  
The selected settings are restored to the instrument or channel.

### To save configurable instrument settings



1. Select the "Save" icon from the toolbar.
2. In the "Save" dialog box, switch to the "Save" tab.
3. In the file selection dialog box, select a filename and storage location for the settings file.
4. Optionally, define a comment to describe the stored settings.
5. Select whether the instrument settings for **all** "Channel" s are stored, or only those for the **current** "Channel" .
6. Select the items to be saved with the settings. Either the settings for the currently selected "Channel" only, or the settings for all "Channel" s can be stored. Various other items, such as lines or traces etc., can be stored as well (see [Chapter 10.3.2.1, "Stored Data Types"](#), on page 254).
7. Select "Save" .

A file with the defined name and path and the extension `.dfl` is created.



If you make any changes to the settings *after* storing the configuration file, remember to save the settings again. Otherwise those settings cannot be restored and will be overwritten by the stored values when the configuration file is recalled.

### To recall configurable instrument settings



1. Select the "Open" icon from the toolbar.
2. In the "Recall" dialog box, switch to the "Recall" tab.
3. In the file selection dialog box, select the filename and storage location of the settings file.  
**Note:** The "File Type" indicates whether the file contains instrument settings for **all** "Channel" s, or only those for the current "Channel" .
4. If several items were saved, select which items are restored.
5. If a "Channel" was saved, select whether the settings will replace the settings in the current "Channel" , or whether a new channel with the saved settings will be opened.
6. Select "Recall" .

The settings and selected items from the saved measurement are restored and you can repeat the measurement with the same settings.

Note that any changes made to the settings *after* storing the configuration file will be overwritten by the stored values when the configuration file is recalled.

**To recall settings automatically after preset or reboot**

You can define the settings that are restored when you preset or reboot the instrument.

1. Configure the settings as required and save them as described in "[To save configurable instrument settings](#)" on page 260.
2. In the "Save/Recall" menu, select "Startup Recall" .
3. From the file selection dialog box, select the recall settings to restore.
4. Select "Select File" .
5. Set "Startup Recall" to "On" .

Now when you press the [PRESET] key or reboot the instrument, the defined settings will be restored.

6. To restore the factory preset settings, set "Startup Recall" to "Off" .

## 10.4 Import/Export Functions



**Access:** "Save" / "Open" icon in the toolbar > "Import" / "Export"



The R&S ESW provides various evaluation methods for the results of the performed measurements. However, you may want to evaluate the data with further, external applications. In this case, you can export the measurement data to a standard format file (ASCII or XML). Some of the data stored in these formats can also be re-imported to the R&S ESW for further evaluation later, for example in other applications.

The following data types can be exported (depending on the application):

- Trace data
- Table results, such as result summaries, marker peak lists etc.
- I/Q data



I/Q data can only be imported and exported in applications that process I/Q data, such as the I/Q Analyzer or optional applications.

See the corresponding user manuals for those applications for details.



These functions are only available if no measurement is running.

In particular, if a continuous measurement is running, the import/export functions are not available.

Export .....	261
L Trace Export Configuration .....	262
L I/Q Export .....	262

**Export**

**Access:** "Save/Recall" > Export

 Opens a submenu to configure data export.

#### **Trace Export Configuration ← Export**

Opens the "Traces" dialog box to configure the trace and data export settings.

[Chapter 9.3.3, "Trace Export"](#), on page 203

#### **I/Q Export ← Export**

Opens a file selection dialog box to define an export file name to which the I/Q data is stored. This function is only available in single sweep mode.

It is only available in applications that process I/Q data, such as the I/Q Analyzer or other optional applications.

For details, see the description in the R&S ESW I/Q Analyzer User Manual ("Importing and Exporting I/Q Data").

**Note:** Storing large amounts of I/Q data (several Gigabytes) can exceed the available (internal) storage space on the R&S ESW. In this case, it can be necessary to use an external storage medium.

**Note:** Secure user mode.

In secure user mode, settings that are stored on the instrument are stored to volatile memory, which is restricted to 256 MB. Thus, a "memory limit reached" error can occur although the hard disk indicates that storage space is still available.

To store data permanently, select an external storage location such as a USB memory device.

For details, see [Chapter 2.7, "Protecting Data Using the Secure User Mode"](#), on page 37.

## 10.5 I/Q Data Import and Export

Baseband signals mostly occur as so-called complex baseband signals, i.e. a signal representation that consists of two channels; the in phase (I) and the quadrature (Q) channel. Such signals are referred to as I/Q signals. I/Q signals are useful because the specific RF or IF frequencies are not needed. The complete modulation information and even distortion that originates from the RF, IF or baseband domains can be analyzed in the I/Q baseband.

Importing and exporting I/Q signals is useful for various applications:

- Generating and saving I/Q signals in an RF or baseband signal generator or in external software tools to analyze them with the R&S ESW later
- Capturing and saving I/Q signals with an RF or baseband signal analyzer to analyze them with the R&S ESW or an external software tool later

As opposed to storing trace data, which may be averaged or restricted to peak values, I/Q data is stored as it was captured, without further processing. The data is stored as complex values in 32-bit floating-point format. Multi-channel data is not supported. The I/Q data is stored in a format with the file extension `.iq.tar`. For a detailed description see [Chapter 10.5.2, "I/Q Data File Format \(iq-tar\)"](#), on page 264.



An application note on converting Rohde & Schwarz I/Q data files is available from the Rohde & Schwarz website:

[1EF85: Converting R&S I/Q data files](#)

The import and export functions are available in the "Save/Recall" menu which is displayed when you select the "Save" or "Open" icon in the toolbar.

- [Import/Export Functions](#)..... 263
- [I/Q Data File Format \(iq-tar\)](#)..... 264

### 10.5.1 Import/Export Functions



**Access:** "Save" / "Open" icon in the toolbar > "Import" / "Export"



The R&S ESW provides various evaluation methods for the results of the performed measurements. However, you may want to evaluate the data with further, external applications. In this case, you can export the measurement data to a standard format file (ASCII or XML). Some of the data stored in these formats can also be re-imported to the R&S ESW for further evaluation later, for example in other applications.

The following data types can be exported (depending on the application):

- Trace data
- Table results, such as result summaries, marker peak lists etc.
- I/Q data (in applications that process I/Q data)

The following data types can be imported (depending on the application):

- I/Q data (in applications that process I/Q data)



I/Q data can only be imported and exported in applications that process I/Q data, such as the I/Q analyzer or other optional applications.

See the corresponding user manuals for those applications for details.



These functions are only available if no measurement is running.

In particular, if a [continuous measurement](#) is active, the import/export functions are not available.

<a href="#">Import</a> .....	263
<a href="#">Export</a> .....	264
L <a href="#">Trace Export Configuration</a> .....	264
L <a href="#">I/Q Export</a> .....	264



#### Import

**Access:** "Save/Recall" > Import



Provides functions to import data.

**Export**

**Access:** "Save/Recall" > Export



Opens a submenu to configure data export.

**Trace Export Configuration ← Export**

Opens the "Traces" dialog box to configure the trace and data export settings.

[Chapter 9.3.3, "Trace Export"](#), on page 203

**I/Q Export ← Export**

Opens a file selection dialog box to define an export file name to which the I/Q data is stored. This function is only available in single sweep mode.

It is only available in applications that process I/Q data, such as the I/Q Analyzer or other optional applications.

For details, see the description in the R&S ESW I/Q Analyzer User Manual ("Importing and Exporting I/Q Data").

**Note:** Storing large amounts of I/Q data (several Gigabytes) can exceed the available (internal) storage space on the R&S ESW. In this case, it can be necessary to use an external storage medium.

**Note:** Secure user mode.

In secure user mode, settings that are stored on the instrument are stored to volatile memory, which is restricted to 256 MB. Thus, a "memory limit reached" error can occur although the hard disk indicates that storage space is still available.

To store data permanently, select an external storage location such as a USB memory device.

For details, see [Chapter 2.7, "Protecting Data Using the Secure User Mode"](#), on page 37.

## 10.5.2 I/Q Data File Format (iq-tar)

I/Q data is packed in a file with the extension `.iq.tar`. An iq-tar file contains I/Q data in binary format together with meta information that describes the nature and the source of data, e.g. the sample rate. The objective of the iq-tar file format is to separate I/Q data from the meta information while still having both inside one file. In addition, the file format allows you to preview the I/Q data in a web browser, and allows you to include user-specific data.

The iq-tar container packs several files into a single `.tar` archive file. Files in `.tar` format can be unpacked using standard archive tools (see [http://en.wikipedia.org/wiki/Comparison\\_of\\_file\\_archivers](http://en.wikipedia.org/wiki/Comparison_of_file_archivers)) available for most operating systems. The advantage of `.tar` files is that the archived files inside the `.tar` file are not changed (not compressed) and thus it is possible to read the I/Q data directly within the archive without the need to unpack (untar) the `.tar` file first.



An application note on converting Rohde & Schwarz I/Q data files is available from the Rohde & Schwarz website:

[1EF85: Converting R&S I/Q data files](#)

### Contained files

An iq-tar file must contain the following files:

- **I/Q parameter XML file**, e.g. `xyz.xml`  
Contains meta information about the I/Q data (e.g. sample rate). The filename can be defined freely, but there must be only one single I/Q parameter XML file inside an iq-tar file.
- **I/Q data binary file**, e.g. `xyz.complex.float32`  
Contains the binary I/Q data of all channels. There must be only one single I/Q data binary file inside an iq-tar file.

Optionally, an iq-tar file can contain the following file:

- **I/Q preview XSLT file**, e.g. `open_IqTar_xml_file_in_web_browser.xslt`  
Contains a stylesheet to display the I/Q parameter XML file and a preview of the I/Q data in a web browser.  
A sample stylesheet is available at [http://www.rohde-schwarz.com/file/open\\_IqTar\\_xml\\_file\\_in\\_web\\_browser.xslt](http://www.rohde-schwarz.com/file/open_IqTar_xml_file_in_web_browser.xslt).

#### 10.5.2.1 I/Q Parameter XML File Specification



The content of the I/Q parameter XML file must comply with the XML schema `RsIqTar.xsd` available at: <http://www.rohde-schwarz.com/file/RsIqTar.xsd>.

In particular, the order of the XML elements must be respected, i.e. iq-tar uses an "ordered XML schema". For your own implementation of the iq-tar file format make sure to validate your XML file against the given schema.

The following example shows an I/Q parameter XML file. The XML elements and attributes are explained in the following sections.

#### Sample I/Q parameter XML file: `xyz.xml`

```
<?xml version="1.0" encoding="UTF-8"?>
<?xml-stylesheet type="text/xsl"
href="open_IqTar_xml_file_in_web_browser.xslt"?>
<RS_IQ_TAR_FileFormat fileFormatVersion="1"
xsi:noNamespaceSchemaLocation="RsIqTar.xsd"
xmlns:xsi="http://www.w3.org/2001/XMLSchema-instance">
  <Name>R&S ESW</Name>
  <Comment>Here is a comment</Comment>
  <DateTime>2011-01-24T14:02:49</DateTime>
  <Samples>68751</Samples>
  <Clock unit="Hz">6.5e+006</Clock>
  <Format>complex</Format>
  <DataType>float32</DataType>
  <ScalingFactor unit="V">1</ScalingFactor>
  <NumberOfChannels>1</NumberOfChannels>
  <DataFilename>xyz.complex.float32</DataFilename>
  <UserData>
```



```

    <UserDefinedElement>Example</UserDefinedElement>
</UserData>
    <PreviewData>...</PreviewData>
</RS_IQ_TAR_FileFormat>

```

Element	Description
RS_IQ_TAR_File-Format	The root element of the XML file. It must contain the attribute <code>fileFormatVersion</code> that contains the number of the file format definition. Currently, <code>fileFormatVersion "2"</code> is used.
Name	Optional: describes the device or application that created the file.
Comment	Optional: contains text that further describes the contents of the file.
DateTime	Contains the date and time of the creation of the file. Its type is <code>xs:dateTime</code> (see <code>RsIqTar.xsd</code> ).
Samples	Contains the number of samples of the I/Q data. For multi-channel signals all channels have the same number of samples. One sample can be: <ul style="list-style-type: none"> <li>• A complex number represented as a pair of I and Q values</li> <li>• A complex number represented as a pair of magnitude and phase values</li> <li>• A real number represented as a single real value</li> </ul> See also <code>Format</code> element.
Clock	Contains the clock frequency in Hz, i.e. the sample rate of the I/Q data. A signal generator typically outputs the I/Q data at a rate that equals the clock frequency. If the I/Q data was captured with a signal analyzer, the signal analyzer used the clock frequency as the sample rate. The attribute <code>unit</code> must be set to "Hz".
Format	Specifies how the binary data is saved in the I/Q data binary file (see <code>DataFilename</code> element). Every sample must be in the same format. The format can be one of the following: <ul style="list-style-type: none"> <li>• <code>complex</code>: Complex number in cartesian format, i.e. I and Q values interleaved. I and Q are unitless</li> <li>• <code>real</code>: Real number (unitless)</li> <li>• <code>polar</code>: Complex number in polar format, i.e. magnitude (unitless) and phase (rad) values interleaved. Requires <code>DataType = float32</code> or <code>float64</code></li> </ul>
DataType	Specifies the binary format used for samples in the I/Q data binary file (see <code>DataFilename</code> element and <a href="#">Chapter 10.5.2.2, "I/Q Data Binary File"</a> , on page 268). The following data types are allowed: <ul style="list-style-type: none"> <li>• <code>int8</code>: 8 bit signed integer data</li> <li>• <code>int16</code>: 16 bit signed integer data</li> <li>• <code>int32</code>: 32 bit signed integer data</li> <li>• <code>float32</code>: 32 bit floating point data (IEEE 754)</li> <li>• <code>float64</code>: 64 bit floating point data (IEEE 754)</li> </ul>
ScalingFactor	Optional: describes how the binary data can be transformed into values in the unit Volt. The binary I/Q data itself has no unit. To get an I/Q sample in the unit Volt the saved samples have to be multiplied by the value of the <code>ScalingFactor</code> . For polar data only the magnitude value has to be multiplied. For multi-channel signals the <code>ScalingFactor</code> must be applied to all channels. <p>The attribute <code>unit</code> must be set to "v".</p> <p>The <code>ScalingFactor</code> must be &gt; 0. If the <code>ScalingFactor</code> element is not defined, a value of 1 V is assumed.</p>

Element	Description
NumberOfChannels	Optional: specifies the number of channels, e.g. of a MIMO signal, contained in the I/Q data binary file. For multi-channels, the I/Q samples of the channels are expected to be interleaved within the I/Q data file (see <a href="#">Chapter 10.5.2.2, "I/Q Data Binary File"</a> , on page 268). If the <code>NumberOfChannels</code> element is not defined, one channel is assumed.
DataFilename	Contains the filename of the I/Q data binary file that is part of the iq-tar file. It is recommended that the filename uses the following convention: <xyz>.<Format>.<Channels>ch.<Type> <ul style="list-style-type: none"> <li>• &lt;xyz&gt; = a valid Windows file name</li> <li>• &lt;Format&gt; = complex, polar or real (see <code>Format</code> element)</li> <li>• &lt;Channels&gt; = Number of channels (see <code>NumberOfChannels</code> element)</li> <li>• &lt;Type&gt; = float32, float64, int8, int16, int32 or int64 (see <code>DataType</code> element)</li> </ul> Examples: <ul style="list-style-type: none"> <li>• xyz.complex.1ch.float32</li> <li>• xyz.polar.1ch.float64</li> <li>• xyz.real.1ch.int16</li> <li>• xyz.complex.16ch.int8</li> </ul>
UserData	Optional: contains user, application or device-specific XML data which is not part of the iq-tar specification. This element can be used to store additional information, e.g. the hardware configuration. User data must be valid XML content.
PreviewData	Optional: contains further XML elements that provide a preview of the I/Q data. The preview data is determined by the routine that saves an iq-tar file (e.g. R&S ESW). For the definition of this element refer to the <code>RsIqTar.xsd</code> schema. Note that the preview can be only displayed by current web browsers that have JavaScript enabled and if the XSLT stylesheet <code>open_IqTar_xml_file_in_web_browser.xslt</code> is available.

### Example: ScalingFactor

Data stored as `int16` and a desired full scale voltage of 1 V

$$\text{ScalingFactor} = 1 \text{ V} / \text{maximum int16 value} = 1 \text{ V} / 2^{15} = 3.0517578125\text{e-}5 \text{ V}$$

Scaling Factor	Numerical value	Numerical value x ScalingFactor
Minimum (negative) int16 value	$-2^{15} = -32768$	-1 V
Maximum (positive) int16 value	$2^{15}-1 = 32767$	0.999969482421875 V

### Example: PreviewData in XML

```
<PreviewData>
  <ArrayOfChannel length="1">
    <Channel>
      <PowerVsTime>
        <Min>
          <ArrayOfFloat length="256">
            <float>-134</float>
            <float>-142</float>
            ...
            <float>-140</float>
          </ArrayOfFloat>
        </Min>
      </PowerVsTime>
    </Channel>
  </ArrayOfChannel>
</PreviewData>
```

```

    <Max>
      <ArrayOfFloat length="256">
        <float>-70</float>
        <float>-71</float>
        ...
        <float>-69</float>
      </ArrayOfFloat>
    </Max>
  </PowerVsTime>
<Spectrum>
  <Min>
    <ArrayOfFloat length="256">
      <float>-133</float>
      <float>-111</float>
      ...
      <float>-111</float>
    </ArrayOfFloat>
  </Min>
  <Max>
    <ArrayOfFloat length="256">
      <float>-67</float>
      <float>-69</float>
      ...
      <float>-70</float>
      <float>-69</float>
    </ArrayOfFloat>
  </Max>
</Spectrum>
<IQ>
  <Histogram width="64" height="64">0123456789...0</Histogram>
</IQ>
</Channel>
</ArrayOfChannel>
</PreviewData>

```

### 10.5.2.2 I/Q Data Binary File

The I/Q data is saved in binary format according to the format and data type specified in the XML file (see `Format` element and `DataType` element). To allow reading and writing of streamed I/Q data, all data is interleaved, i.e. complex values are interleaved pairs of I and Q values and multi-channel signals contain interleaved (complex) samples for channel 0, channel 1, channel 2 etc. If the `NumberOfChannels` element is not defined, one channel is presumed.

#### Example: Element order for real data (1 channel)

```

I[0],           // Real sample 0
I[1],           // Real sample 1
I[2],           // Real sample 2
...

```

**Example: Element order for complex cartesian data (1 channel)**

```
I[0], Q[0],           // Real and imaginary part of complex sample 0
I[1], Q[1],           // Real and imaginary part of complex sample 1
I[2], Q[2],           // Real and imaginary part of complex sample 2
...
```

**Example: Element order for complex polar data (1 channel)**

```
Mag[0], Phi[0],       // Magnitude and phase part of complex sample 0
Mag[1], Phi[1],       // Magnitude and phase part of complex sample 1
Mag[2], Phi[2],       // Magnitude and phase part of complex sample 2
...
```

**Example: Element order for complex cartesian data (3 channels)**

Complex data: I[channel no][time index], Q[channel no][time index]

```
I[0][0], Q[0][0],     // Channel 0, Complex sample 0
I[1][0], Q[1][0],     // Channel 1, Complex sample 0
I[2][0], Q[2][0],     // Channel 2, Complex sample 0

I[0][1], Q[0][1],     // Channel 0, Complex sample 1
I[1][1], Q[1][1],     // Channel 1, Complex sample 1
I[2][1], Q[2][1],     // Channel 2, Complex sample 1

I[0][2], Q[0][2],     // Channel 0, Complex sample 2
I[1][2], Q[1][2],     // Channel 1, Complex sample 2
I[2][2], Q[2][2],     // Channel 2, Complex sample 2
...
```

**Example: Element order for complex cartesian data (1 channel)**

This example demonstrates how to store complex cartesian data in float32 format using MATLAB®.

```
% Save vector of complex cartesian I/Q data, i.e. iqiqli...
N = 100
iq = randn(1,N)+1j*randn(1,N)
fid = fopen('xyz.complex.float32','w');
for k=1:length(iq)
    fwrite(fid, single(real(iq(k))), 'float32');
    fwrite(fid, single(imag(iq(k))), 'float32');
end
fclose(fid)
```

## 10.6 Creating Screenshots of Current Measurement Results and Settings

To document the graphical results and the most important settings for the currently performed measurement, you can create a screenshot of the current display. Screenshots can either be printed or stored to a file.

- [Print and Screenshot Settings](#).....270
- [How to Store or Print Screenshots of the Display](#)..... 278
- [Example for Storing Multiple Measurement Results to a PDF File](#)..... 280

### 10.6.1 Print and Screenshot Settings



**Access:** "Print" icon in the toolbar

For step-by-step instructions, see [Chapter 10.6.2, "How to Store or Print Screenshots of the Display"](#), on page 278.

Remote commands for these settings are described in [Chapter 13.8.4, "Screenshots and Printouts"](#), on page 582.



To print a screenshot of the current display with the current settings immediately, without switching to the "Print" menu, use the "Print immediately" icon in the toolbar.

- [Print Content Settings](#)..... 270
- [Print Preview Functions](#)..... 272
- [Printer Settings](#).....274
- [Page Setup](#)..... 276
- [Print Color Settings](#)..... 277

#### 10.6.1.1 Print Content Settings



**Access:** "Print" > "Print Config" > "Content" tab

The content settings determine which data is included in the printout.

Note that some content settings are independent of the selected printing device, others are printing device-specific.

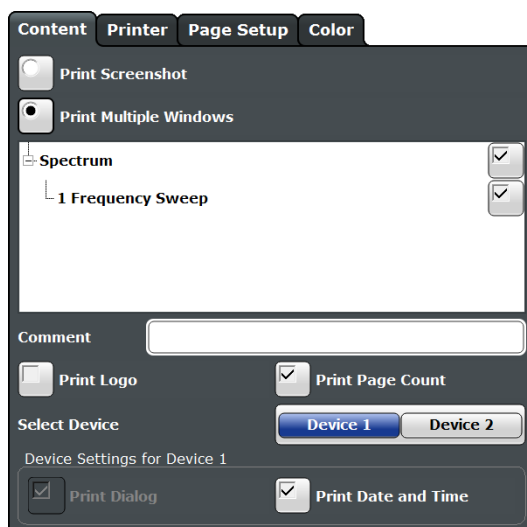

Print Screenshot .....271

Print Multiple Windows .....271

Comment .....272

Print Logo .....272

Print Page Count .....272

Select Device 1/2 .....272

Print Dialog .....272

Print Date and Time .....272

**Print Screenshot**

Selects all measurement results displayed on the screen for the current channel (or "MultiView" ): diagrams, traces, markers, marker lists, limit lines, etc., including the channel bar and status bar, for printout on a single page. Displayed items belonging to the software user interface (e.g. softkeys) are not included. The position and size of the elements in the printout is identical to the display.

This setting is independent of the printing device.

Remote command:  
 HCOP:CONT HCOP

**Print Multiple Windows**

Includes only the selected windows in the printout. All currently active windows for the current channel (or "MultiView" ) are available for selection. How many windows are printed on a single page of the printout is user-definable (see " Windows Per Page " on page 276).

This option is only available when printing on a printer or to a PDF file (see " Destination " on page 275). If the Destination is currently set to an image file or the clipboard for the selected printing device, it is automatically changed to be a PDF file.

Remote command:  
 HCOP:CONT WIND  
 HCOPy:PAGE:WINDow<device>:STATe on page 592  
 HCOPy:PAGE:WINDow<device>:CHANnel:STATe on page 590

**Comment**

Defines an optional comment to be included in the printout of the display. Maximum 120 characters are allowed. Up to 60 characters fit in one line. In the first line, a manual line-feed can be forced at any point by entering "@".

The comment is printed in the top left corner of each printout page. If a comment should not be printed, it must be deleted.

This setting is independent of the printing device.

**Tip:** The current date and time can be inserted automatically, see "[Print Date and Time](#)" on page 272.

Remote command:

`HCOPY:ITEM:WINDOW:TEXT` on page 588

**Print Logo**

Activates/deactivates the printout of the Rohde & Schwarz company logo in the upper right corner.

This setting is independent of the printing device.

Remote command:

`DISPLAY:LOGO` on page 583

**Print Page Count**

Includes the page number for printouts consisting of multiple windows ("[Print Multiple Windows](#)" on page 271).

This setting is independent of the printing device.

Remote command:

`HCOPY:PAGE:COUNT:STATE` on page 588

**Select Device 1/2**

Selects the printing device to be configured.

Two different printout devices can be configured, for example one for printing and one for storage to a file. When you execute the "Print immediately" function, the selected printing device and its settings determine the behavior of the R&S ESW.

**Print Dialog**

Includes any currently displayed dialog in the screenshot printout.

This setting is (printing) device-specific and only available if [Print Screenshot](#) is selected.

**Print Date and Time**

Includes or removes the current date and time at the bottom of the printout.

This setting is (printing) device-specific.

Remote command:

`HCOPY:TDSTAMP:STATE<device>` on page 593

**10.6.1.2 Print Preview Functions**



**Access: "Print"**

The "Print Preview" of the printout according to the current configuration is available in all "Print Settings" dialog tabs.

The preview display (not the functions) is device-specific (see " [Select Device 1/2](#) " on page 272).

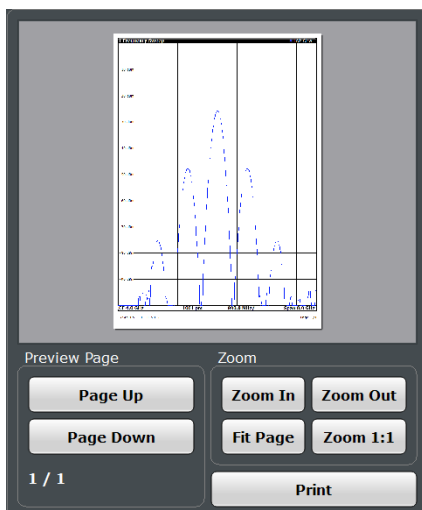

[Zoom In / Zoom Out](#) .....273

[Fit Page](#) .....273

[Zoom 1:1](#) .....273

[Page Up / Page Down](#) .....273

[Print](#) .....273

**Zoom In / Zoom Out**

Zooms into (enlarges) or zooms out of (decreases) the preview display. Note that the zoom functions affect only the preview, not the printout itself.

**Fit Page**

Adapts the preview display zoom factor so that one complete page is visible as large as possible in the available display space. Note that the zoom functions affect only the preview, not the printout itself.

**Zoom 1:1**

Displays the printout in its original size, as it will be printed.

**Page Up / Page Down**

Depending on the selected contents (see [Chapter 10.6.1.1, "Print Content Settings"](#), on page 270), the printout can consist of multiple pages. Use these functions to scroll within the preview to see the individual pages.

**Print**

Starts to print or store the selected screen contents to a file (see [Chapter 10.6.1.1, "Print Content Settings"](#), on page 270).



Whether the output is sent to the printer or stored in a file or the clipboard depends on the selected printing device and the printing device settings (see [Chapter 10.6.1.3, "Printer Settings"](#), on page 274).

If the output is stored to a file, a file selection dialog box is opened to select the file-name and location. The default path is C:\R\_S\Instr\User.

Remote command:

HCOPY[:IMMEDIATE<device>] on page 587

HCOPY[:IMMEDIATE<device>]:NEXT on page 588

### 10.6.1.3 Printer Settings



**Access:** "Print" > "Print Config" > "Printer" tab



Printer settings are (printing) device-specific. That means you can configure two different printing devices (for example, a printer and a file) and switch between configurations easily simply by selecting the appropriate device before printing.

<a href="#">Select Device 1/2</a> .....	274
<a href="#">Destination</a> .....	275
<a href="#">Suppress File Name Dialog</a> .....	275
<a href="#">Printer Name</a> .....	275
<a href="#">Print to file</a> .....	275
<a href="#">Install Printer</a> .....	275

#### Select Device 1/2

Selects the printing device to be configured.

Two different printout devices can be configured, for example one for printing and one for storage to a file. When you execute the "Print immediately" function, the selected printing device and its settings determine the behavior of the R&S ESW.

**Destination**

Defines the medium to which the printout is output.

- "File" Stores the printout to a file in the selected format. The filename is queried at the time of storage, or a default name is used (see [Suppress File Name Dialog](#) ).  
Multiple windows can only be printed to a file in PDF format. If you select an image file format, the content setting is automatically set to [Print Screenshot](#) . Page settings are not available for image files; however, you can configure the colors used for the screenshot (see [Chapter 10.6.1.5, "Print Color Settings"](#), on page 277).
- "Clipboard" Copies the printout to the clipboard. Since only single pages can be copied, only screenshots can be copied to this destination, not multiple windows (see [Chapter 10.6.1.1, "Print Content Settings"](#), on page 270). Page settings are not available; however, you can configure the colors used for the screenshot (see [Chapter 10.6.1.5, "Print Color Settings"](#), on page 277).  
If you select the clipboard as the printing destination, the content setting is automatically set to [Print Screenshot](#) .
- "Printer" Sends the printout to the printer selected from the [Printer Name](#) list.

Remote command:

[HCOPY:DESTination<device>](#) on page 586

[HCOPY:DEVice:LANGUage<device>](#) on page 587

**Suppress File Name Dialog**

If the [Destination](#) is a file, the file selection dialog box is not displayed. Instead, the default storage location and filename are used.

(C:\R\_S\Instr\User\ESW\_ScreenShot\_<date and time>).

**Printer Name**

Defines the printer to print to if a printer is selected as the [Destination](#) .

Any printers detected in the network are listed for selection.

**Tip:** the printout can also be stored in a print file using the selected printer driver, see "[Print to file](#)" on page 275.

Remote command:

[SYSTEM:COMMunicate:PRINter:ENUMerate\[:NEXT\]?](#) on page 593

[SYSTEM:COMMunicate:PRINter:ENUMerate:FIRSt?](#) on page 593

[SYSTEM:COMMunicate:PRINter:SElect<device>](#) on page 594

**Print to file**

If a printer is selected as the [Destination](#) , use this option to store the data in a .prn file using the selected printer driver.

**Install Printer**

This softkey opens the standard Windows dialog box to install a new printer. All printers that are already installed are displayed.

Only user accounts with administrator rights can install a printer.

For further information, refer to the Microsoft Windows documentation.

### 10.6.1.4 Page Setup



**Access:** "Print" > "Print Config" > "Page Setup" tab

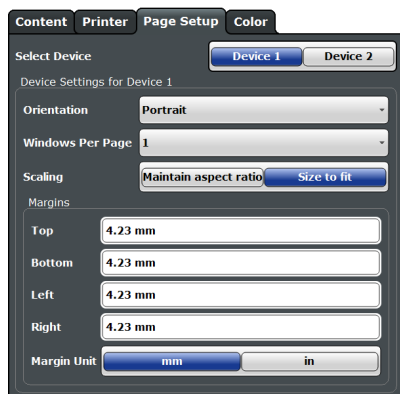

Page settings are (printing) device-specific. That means you can configure two different printing devices (for example, a printer and a file) and switch between configurations easily simply by selecting the appropriate device before printing.

Page settings are only available when printing on a printer or to a PDF file (see "Destination" on page 275).

Select Device 1/2 .....	276
Orientation .....	276
Windows Per Page .....	276
Scaling .....	277
Margins .....	277

#### Select Device 1/2

Selects the printing device to be configured.

Two different printout devices can be configured, for example one for printing and one for storage to a file. When you execute the "Print immediately" function, the selected printing device and its settings determine the behavior of the R&S ESW.

#### Orientation

Selects the page orientation of the printout: portrait or landscape.

Remote command:

HCOPY:PAGE:ORientation<device> on page 590

#### Windows Per Page

Defines how many windows are displayed on a single page of the printout. This setting is only available if [Print Multiple Windows](#) is active (see [Chapter 10.6.1.1, "Print Content Settings"](#), on page 270).

If more than one window is printed on one page, each window is printed in equal size.

Remote command:

`HCOPY:PAGE:WINDow<device>:COUNT` on page 591

### Scaling

Determines the scaling of the windows in the printout if [Print Multiple Windows](#) is active (see [Chapter 10.6.1.1, "Print Content Settings"](#), on page 270).

If more than one window is printed on one page (see [Windows Per Page](#) ), each window is printed in equal size.

"Maintain aspect ratio" Each window is printed as large as possible while maintaining the aspect ratio of the original display.

"Size to fit" Each window is scaled to fit the page size optimally, not regarding the aspect ratio of the original display.

Remote command:

`HCOPY:PAGE:WINDow<device>:SCALE` on page 591

### Margins

Defines margins for the printout page on which no elements are printed. The margins are defined according to the selected unit.

Remote command:

`HCOPY:PAGE:MARGIN<device>:BOTTOM` on page 588

`HCOPY:PAGE:MARGIN<device>:LEFT` on page 589

`HCOPY:PAGE:MARGIN<device>:RIGHT` on page 589

`HCOPY:PAGE:MARGIN<device>:TOP` on page 589

`HCOPY:PAGE:MARGIN<device>:UNIT` on page 590

## 10.6.1.5 Print Color Settings



**Access:** "Print" > "Print Config" > "Color" tab

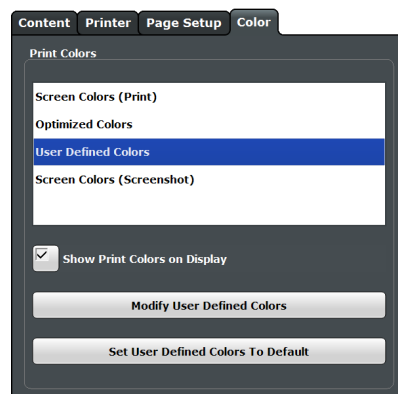

The settings provided here are identical to those in the "Print Colors" section of the "Display" > "Theme + Color" dialog box.

See "[Print Colors](#)" on page 301.

## 10.6.2 How to Store or Print Screenshots of the Display

The measurement results displayed on the screen can be printed or stored to a file very easily.

Two different scenarios can be configured in parallel, assigned to different printing devices. You can then perform one or the other simply by selecting the corresponding printing device and the "Print" function.

### To start printing or storing results to a file



- ▶ If the R&S ESW has already been set up according to your current requirements, simply press the "Print immediate" icon at the far right end of the toolbar.



The current measurement display is printed or stored to a file, as configured.

### To print a screenshot

This configuration assumes a printer has already been installed. To install a new printer, use the [Install Printer](#) function (common Microsoft Windows procedure).



1. Select the "Printer" tool in the toolbar.  
The "Print Settings" dialog box is displayed.
2. Select "Device 1" or "Device 2" to define which printing device you want to configure.  
(Note: Some settings are independent of the printing-device.)
3. In the "Content" tab, define the elements of the screen and additional information to be included in the printout.
  - a) Select "Print Screenshot" to include all elements displayed on the screen in a single-page printout.
  - b) Optionally, add a comment to be printed at the top of the printout.
  - c) Optionally, activate the date and time or the logo so they are added to the printout.
  - d) Optionally, activate "Print Dialog" to include any dialog boxes currently displayed on the screen in the printout. This is useful, for example, to document the used settings for a particular result.
  - e) Check the "Print Preview" to make sure all relevant elements of the display are visible.
4. In the "Printer" tab, select "Printer" as the "Destination" .
5. Select the "Printer Name" to print to from the list of installed printers.
6. In the "Page Setup" tab, configure the layout of the printout page.
  - a) Select the page orientation.
  - b) Define the page margins.
  - c) Check the "Print Preview" to make sure all relevant elements of the display are visible.
7. In the "Color" tab, define the colors to be used for the printout.

- a) By default, "Optimized Colors" are used to improve the visibility of the colors. The background is always printed in white and the grid in black. For a printout that reflects exactly what you see on the screen, select "Screen Colors (Screenshot)" .
  - b) Check the "Print Preview" to find out if the setting is appropriate.
8. Select "Print" to execute the print function.  
The screenshot is printed on the printer as configured.
-  9. To print another screenshot using the same configuration any other time, simply press the "Print immediate" icon at the far right end of the toolbar. If you use different printing scenarios alternately, perform the following steps to print another screenshot:
- a) Select the  "Printer" tool in the toolbar.
  - b) Select "Device 1" or "Device 2" to select the configured printing device.
  - c) Select "Print" to execute the print function.

#### To store a printout containing multiple windows



1. Select the "Printer" tool in the toolbar.  
The "Print Settings" dialog box is displayed.
2. Select "Device 1" or "Device 2" to define which printing device you want to configure.
3. In the "Content" tab, define the elements of the screen and additional information to be included in the printout.
  - a) Select "Print Selected Windows" to include the selected windows in the printout, possibly on multiple pages.
  - b) Select the result displays in the currently selected channel to be included in the printout.  
**Tip:** Select the "MultiView" before configuring the printout to include result displays from any active channel.
  - c) Optionally, add a comment to be printed at the top of each page of the printout.
  - d) Optionally, activate the date and time or the logo so they are added to the printout pages.
4. Check the "Print Preview" to make sure all required result displays are included.
  - a) Scroll through the individual pages of the printout using "Page Up" and "Page Down" .
  - b) Use the zoom functions to make sure all relevant parts of the result display are visible.
5. In the "Printer" tab, select "File" as the "Destination" .
6. Select the file format from the selection list.
7. By default, you define the filename individually for each print operation. To avoid having the "File Selection" dialog box being displayed for each print operation,

select "Suppress File Name Dialog" . In this case, the previously used or default storage location and filename are used.

(C:\R\_S\Instr\User\ESW\_ScreenShot\_<date and time>).

8. In the "Page Setup" tab, configure the layout of the printout page.
  - a) Select the page orientation.
  - b) Define the page margins.
  - c) Check the "Print Preview" to make sure all relevant elements of the display are visible.
9. In the "Color" tab, define the colors to be used for the printout.
  - a) By default, "Optimized Colors" are used to improve the visibility of the colors. The background is always printed in white and the grid in black. For a printout that reflects the colors you see on the screen, but with a white background, select "Screen Colors (Print)" .
  - b) Check the "Print Preview" to find out if the setting is appropriate.
10. Select "Print" to execute the print function.
11. If you did not select the option to suppress the dialog, enter a filename in the file selection dialog box.

The selected data elements are stored to the file as configured.



12. To store another file using the same configuration any other time, simply press the "Print immediate" icon at the far right end of the toolbar. If you use different printing scenarios alternately, perform the following steps to store another file:
  - a) Select the  "Printer" tool in the toolbar.
  - b) Select "Device 1" or "Device 2" to select the configured printing device.
  - c) Select "Print" to execute the print function.

### 10.6.3 Example for Storing Multiple Measurement Results to a PDF File

The following example describes the procedure to store results from measurements in the Spectrum application and the I/Q Analyzer to a single PDF file.

1. Configure and perform the measurements in the Spectrum application and I/Q Analyzer as required. Configure at least the following result displays:
  - Frequency Sweep, Spectrogram (Spectrum)
  - Magnitude, Spectrum (I/Q Analyzer)
2. Switch to the "MultiView" tab to display an overview of the result displays in all active channels.

## Creating Screenshots of Current Measurement Results and Settings

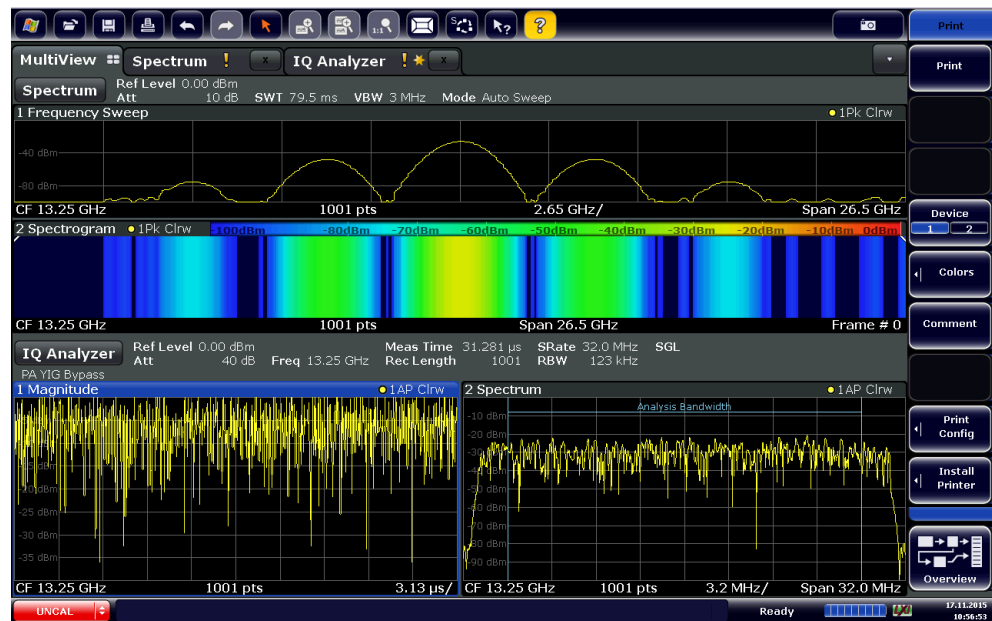

3. Select the "Printer" tool in the toolbar.  
The "Print Settings" dialog box is displayed.
4. Select "Device 1" to configure the settings for this printing device.
5. In the "Content" tab, select "Print Selected Windows" .
6. Select the result displays listed in [step 1](#).
7. Enter the comment *Measurement Test Report* to be inserted at the top of each page.
8. Select "Print Page Count" and "Print Date and Time" .
9. In the "Content" tab, select "Print Selected Windows" .
10. In the "Printer" tab, select "File" as the "Destination" .
11. Select "PDF" from the file format selection list.
12. Select "Suppress File Name Dialog" .
13. In the "Page Setup" tab, select "Landscape" as the "Orientation" .
14. Select "Windows Per Page" : 1 to print a single result display on each page.
15. Select the "Scaling" option "Size to fit" to maximize the result display on each page.
16. In the "Color" tab, select "Screen Colors (Print)" for a printout that reflects the colors you see on the screen, but with a white background.
17. Check the "Print Preview" to make sure all required result displays are included and all relevant data elements are visible.
  - a) Scroll through the individual pages of the printout using "Page Up" and "Page Down" .



- b) Use the zoom functions to make sure all relevant parts of the result display are visible.
18. Select "Print" to execute the print function.
- The selected data elements are stored to the file as configured.

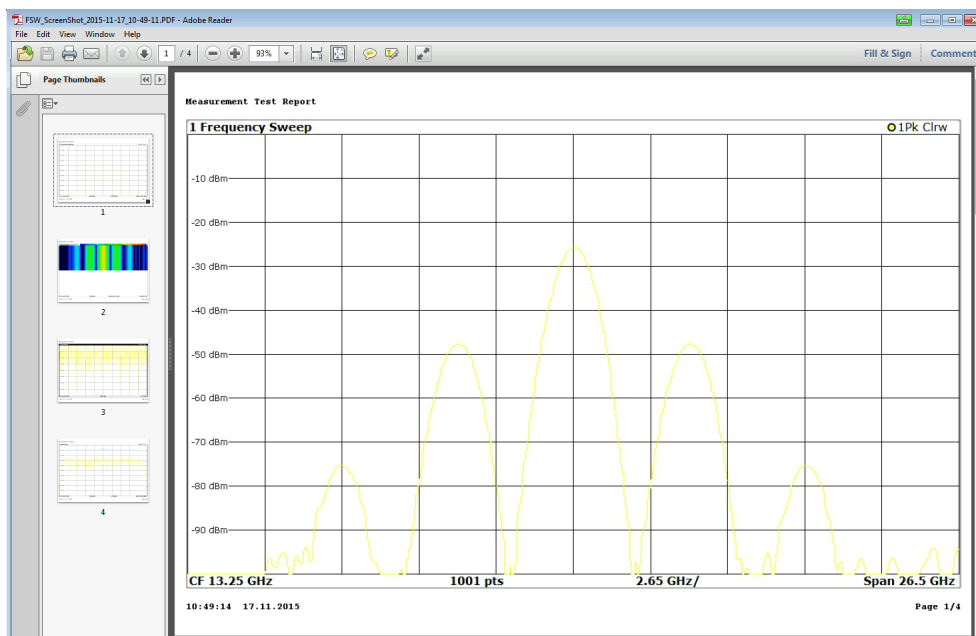

## 10.7 Working with Test Reports

The R&S ESW features a test report generator. A test report is a document that summarizes the results and configuration of measurements.

A test report is made up out of one or more datasets. Each dataset contains the results and configuration of one measurement.

- [Designing a Test Report Template](#)..... 282
- [Creating a Test Report](#)..... 287

### 10.7.1 Designing a Test Report Template

**Access:** > "Templates"

The R&S ESW allows you to create test report templates, for example if you handle different measurement tasks that require different information or a different layout in the test report. The following topics show you ways to customize your test reports and save those settings in a template.

Selecting the Test Report Contents.....283  
 Defining general properties of the test report document..... 283  
 Adding custom information about the measurement.....284  
 Defining the contents of the title page.....285  
 Managing Templates.....286

**Selecting the Test Report Contents**

The properties available in the "Templates" tab define the information that each dataset in the test report should contain. You can add or remove the items as required.

The contents of the dialog box depend on the application (Receiver, Spectrum etc.).

In all applications, you can add different graphical results ("Diagrams" category), numerical results or information about the measurement setup or configuration ("Tables" category). Information that is to be included in the test report is represented by a blue button. Information not included is represented by a gray button.

Refer the individual dialog boxes for a comprehensive list of information that you can add to a test report.

For more information about the "General" tab of the dialog box, see "Adding custom information about the measurement" on page 284 and "Defining the contents of the title page" on page 285.



Remote command:

[HCOPY:TREPort:ITEM:SElect](#) on page 599

[HCOPY:TREPort:ITEM:DEFault](#) on page 596

**Defining general properties of the test report document**

**Access:** > "Templates" > "General" > "v" > "General"

The "General" category defines general properties of the report document.

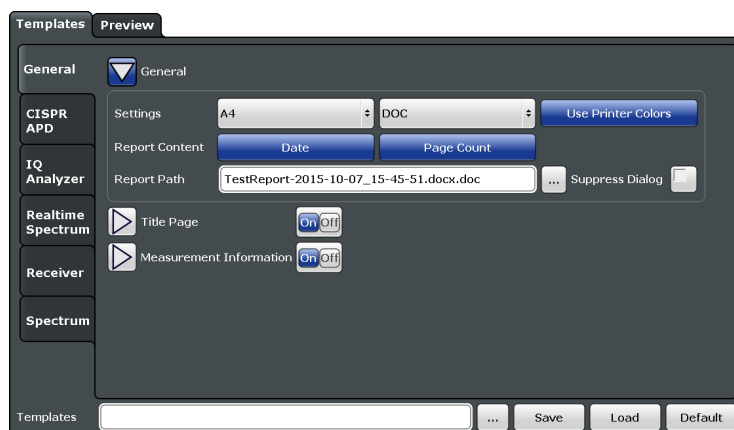

The following document properties are supported.

- **Format**  
Selects the format of the document (A4 or Letter format).
- **File type**  
Selects the file type (.pdf or .doc)
- **Use Screen Colors**  
Turns the use of printer friendly color schemes on and off.
- **Date**  
Adds the current date to the report.
- **Page Count**  
Adds page numbers to the report.
- **Report Path**  
Defines the name of the report and the location where the report file is to be saved. You can specify the directory with the "..." button or by entering a path and filename into the input field.  
When you omit the path, the report is saved in the default directory (C:\R\_S\Instr\user).  
**Note:** This is the location of the actual test report. [Templates](#) are stored in a different location.
- **Suppress Dialog**  
Turns a confirmation dialog box that is shown when you save the report on and off. When the confirmation dialog is suppressed, reports are saved to the default directory with a generic name.

Remote command:

Format: `HCOPY:TREPort:PAGEsize` on page 603

File type: `HCOPY:DEvice:LANGuage<device>` on page 587

Page numbers: `HCOPY:TREPort:PAGEcount:STATe` on page 603

Color: `HCOPY:TREPort:PCOLors[:STATe]` on page 604

Date and time: `HCOPY:TREPort:TDSTamp[:STATe]` on page 604

### Adding custom information about the measurement

**Access:** > "Templates" > "General" > "v" > "Measurement Information"

When you turn it on, the "Measurement Information" category allows you to add custom information about the measurement to the report. You can also define how often that information is added to the report.

You can add up to **six lines** to the report, plus **one picture** (for example a company logo). Each of the six lines consists of a **title** and a **value** (which is displayed next to the title). In addition, you can select how each line in the header is treated (the **visibility**).

The title and value are arbitrary strings. The application, however, comes with several predefined titles (except for the "Heading" title, you can change all others).

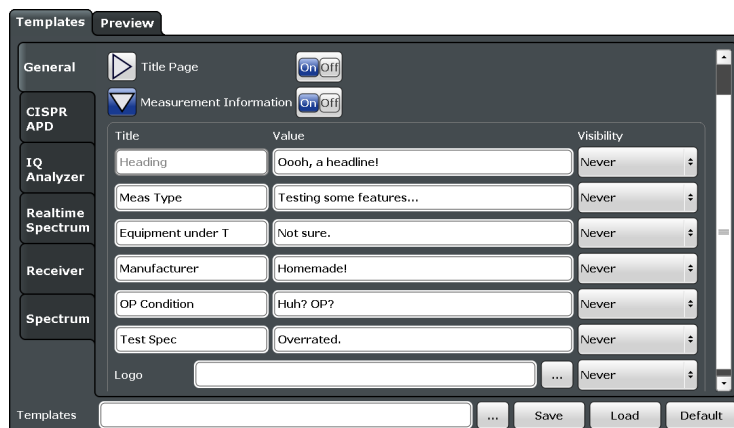

- **Title**  
Defines a name for a variable that has different values depending on the measurement (for example the name of the EUT). The firmware comes with some predefined titles, but you can change and customize each title.
- **Value**  
Defines the value of the variable defined by the title.
- **Visibility**  
Selects if a line is displayed on every page in the header of the report ("Global"), below a main chapter title ("Subreport") or not at all ("Never").  
By default, the information is not displayed at all.

### Adding a logo

The page header can also contain a picture or logo. You can upload a picture with the "..." symbol. The "..." symbol opens a dialog box to select a file.

Reports support pictures in .bmp, .jpg, .png, .gif, .emf or .wmf format.

Similar to the alphanumeric lines in the header, you can select the visibility for the logo as well. By default, the logo is not displayed in the report.

Remote command:

State: `HCOPY:TREPort:ITEM:HEADer:STATe` on page 598

Title: `HCOPY:TREPort:ITEM:HEADer:LINE<line>:TITLe` on page 597

Value: `HCOPY:TREPort:ITEM:HEADer:LINE<line>:TEXT` on page 596

Visibility: `HCOPY:TREPort:ITEM:HEADer:LINE<line>:CONTrol` on page 596

Selection of logo: `HCOPY:TREPort:ITEM:LOGO` on page 598

Visibility of logo: `HCOPY:TREPort:ITEM:LOGO:CONTrol` on page 599

### Defining the contents of the title page

Access: `[Icon] > "Templates" > "General" > "v" > "Title Page"`

When you turn it on, the "Title" category defines the contents of the first page of the test report (title page).

You can define a title for the test report, which is printed in big and bold letters on the first page, and a short description of the contents of the test report (or the name of the author or something similar). This description is also part of the first test report page, but is printed in normal letters.

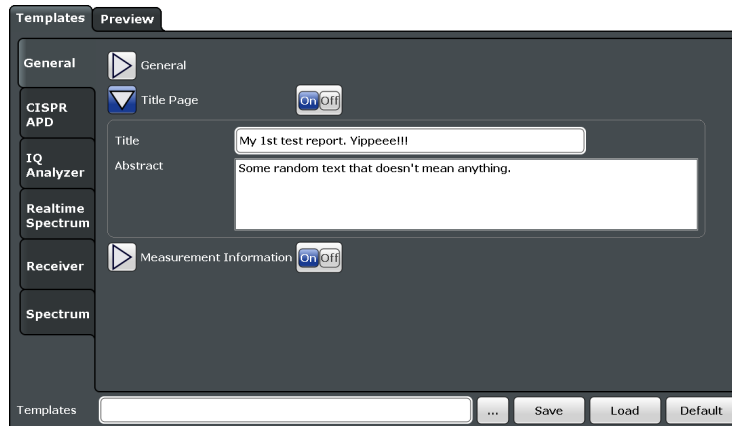

Remote command:

State: [HCOPY:TREPort:TITLe:STATe](#) on page 606

Title: [HCOPY:TREPort:TITLe](#) on page 605

Description: [HCOPY:TREPort:DEScRiption](#) on page 595

### Managing Templates

The "Templates" category contains functions to manage test report templates.

Test report management functions are always visible (at the bottom).

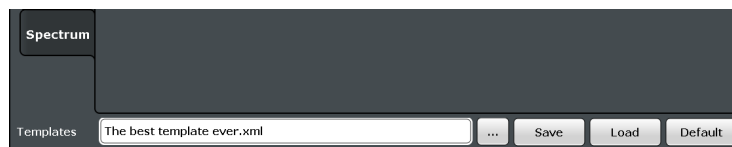

- Load  
Restores the selected test report configuration.
- Save  
Saves the current test report configuration. Before you save the configuration as a template, enter a name for the template in the corresponding field.  
You can specify the directory with the "..." button or by entering a path and filename into the input field.  
When you omit the path, the report is saved in the default directory.
- Default  
Restores the default template configuration.

Remote command:

Query available templates: [HCOPY:TREPort:ITEM:TEMPLate:CATalog?](#)  
on page 602

Save template: [HCOPY:TREPort:ITEM:TEMPLate:SAVE](#) on page 603



Load template: [HCOPY:TREPort:ITEM:TEMPLate:LOAD](#) on page 602

Default template: [HCOPY:TREPort:ITEM:DEFault](#) on page 596

### 10.7.2 Creating a Test Report

Access:  > "Preview"

#### Generating report data

- Create a new dataset of the selected measurement channel from scratch:  (Existing datasets will be deleted.)
- Append a new dataset of the selected measurement channel to an existing dataset: 



#### Test report limitations

The size of the test report is limited to 50.000 measurement points per trace.

If the number of measurement points is greater than that value, only the first 50.000 values are written to the report. The rest is dismissed.

Try to do an ASCII file export when you have more measurement points.

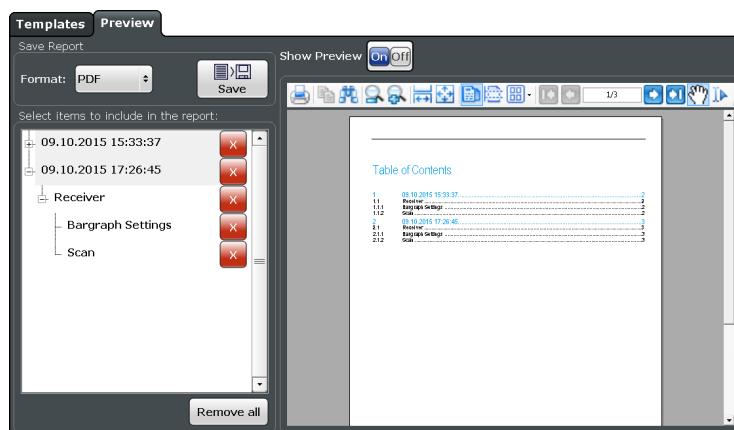

[Configuring and Printing the Test Report](#)..... 287

[Adding and Removing Datasets](#).....287

#### Configuring and Printing the Test Report

You can save the test report either as a **pdf** document or an **doc** document in the corresponding dropdown menu in the "Report Content" dialog box.

The "Preview" feature, if it is turned on, opens a preview version of the test report in the corresponding pane of the dialog box. Note that it can take a short time until the preview has been created.

The "Save" button saves the test report. When you [suppress the file dialog](#), the report is saved to the directory you have specified in the [Report Path](#) input field.

Remote command:

Print mode: [HCOPY:MODE](#) on page 595



Print report: [HCOPY\[:IMMEDIATE<device>\]](#) on page 587

Report name and directory: [MMEMORY:NAME](#) on page 573

#### Adding and Removing Datasets

Before you can print a test report, you have to fill it with data.

Test report data is organized in datasets. Each dataset contains the results of one measurement or the settings of one measurement (which can result in several sub-sets):

You can generate datasets with the  (generate new dataset) or  (append data to the existing dataset).

After you have created a dataset, you can view the details in the "Select Items to Include in the Report" pane of the "Report Content" dialog box.

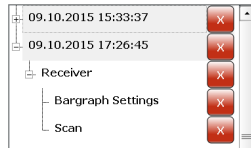

All datasets in the list are exported to the report. To delete a dataset, use the cross next to the dataset label.

The "Remove All" feature deletes all datasets.

Remote command:

New report: [HCOpy:TREPort:NEW](#) on page 603

Add dataset: [HCOpy:TREPort:APPend](#) on page 595

Remove dataset: [HCOpy:TREPort:TEST:REMOve](#) on page 604

Remove all datasets: [HCOpy:TREPort:TEST:REMOve:ALL](#) on page 605

# 11 General Instrument Setup

**Access:** [SETUP]

Some basic instrument settings can be configured independently of the selected operating mode or application. Usually, you will configure most of these settings initially when you set up the instrument according to your personal preferences or requirements and then only adapt individual settings to special circumstances when necessary. Some special functions are provided for service and basic system configuration.



## Network and Remote Settings, Display Settings

Settings for network and remote operation are described in [Chapter 12, "Network and Remote Operation"](#), on page 344.

Display settings are described in [Chapter 11.2.1, "Display Settings"](#), on page 294.

- [Alignment](#)..... 289
- [Display Settings](#)..... 294
- [Transducers](#)..... 305
- [Reference Frequency Settings](#)..... 320
- [System Configuration Settings](#)..... 323
- [Service Functions](#)..... 329
- [Synchronizing Measurement Channel Configuration](#)..... 335

## 11.1 Alignment

### 11.1.1 Basics on Alignment

When you put the instrument into operation for the first time or when strong temperature changes occur, align the data to a reference source (see ["Temperature check"](#) on page 290).

The correction data and characteristics required for the alignment are determined by the firmware. It compares the results at different settings with the known characteristics of the high-precision calibration signal source at 64 MHz.



Depending on the installation settings, an automatic self-alignment is performed directly after installation, and a dialog is displayed indicating how much warm-up time is still required before self-alignment can be performed.



During instrument start, the firmware checks whether the installed hardware is supported. If not, an error message is displayed ( "Wrong Firmware Version" ) and you are asked to update the firmware. Until the firmware version is updated, self-alignment fails.





If you start a self-alignment remotely and then select the "Local" softkey while the alignment is still running, the instrument only returns to the manual operation state after the alignment is completed.

### Alignment results

The alignment results are displayed and contain the following information:

- Date and time of last correction data record
- Overall results of correction data record
- List of found correction values according to function/module

The results are classified as follows:

<b>PASSED</b>	Calibration successful without any restrictions
<b>CHECK</b>	Deviation of correction value larger than expected, correction could however be performed
<b>FAILED</b>	Deviations of correction value too large, no correction was possible. The found correction data is not applicable.

The results are available until the next self-alignment process is started or the instrument is switched off.

### Temperature check

During self-alignment, the instrument's (frontend) temperature is also measured (as soon as the instrument has warmed up completely). This temperature is used as a reference for a continuous temperature check during operation. If the current temperature deviates from the stored self-alignment temperature by a certain degree, a warning is displayed in the status bar. The warning indicates the resulting deviation in the measured power levels. A status bit in the `STATUS:QUESTIONABLE:TEMPERATURE` register indicates a possible deviation. The current temperature of the RF frontend can be queried using a remote command (see `SOURCE:TEMPERATURE:FRONTEND?` on page 617).

### Touchscreen alignment

When the device is delivered, the touchscreen is initially calibrated. However, to ensure that the touchscreen responds to the finger contact correctly, a touchscreen alignment is required.

Alignment of the touchscreen is useful:

- At first use
- After an image update or after exchanging a hard disk
- If you notice that touching a specific point on the screen does not achieve the correct response
- If the position of the instrument has been changed and you cannot look straight on the screen
- If another person operates the instrument

## 11.1.2 Alignment Settings

**Access:** [Setup] > "Alignment"

Both the instrument and the touchscreen can be aligned when necessary (see [Chapter 11.1.1, "Basics on Alignment"](#), on page 289).



### Automatic self-alignment

During installation of the R&S ESW firmware, you can configure an automatic self-alignment to be performed directly after installation. In addition, you can activate a preceding warmup time before self-alignment, which is strongly recommended. If you do not activate this option, make sure the instrument has reached its operating temperature before installing the firmware. Furthermore, you can force the instrument to shut down after self-alignment. Note, however, that you cannot switch the instrument back on remotely afterwards.

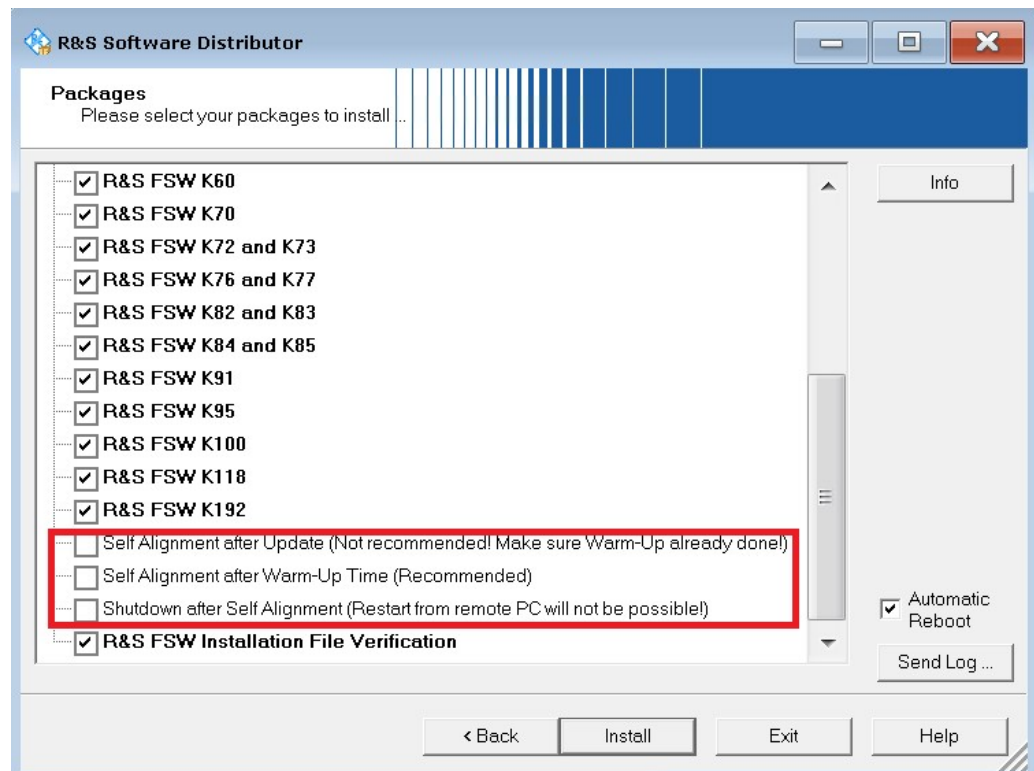

The additional settings for self-alignment can also be activated or deactivated during operation in the "Alignment" settings dialog (see [Await Warm-Up Operation before Self Alignment](#) and [Shut down Device after Self Alignment](#).)

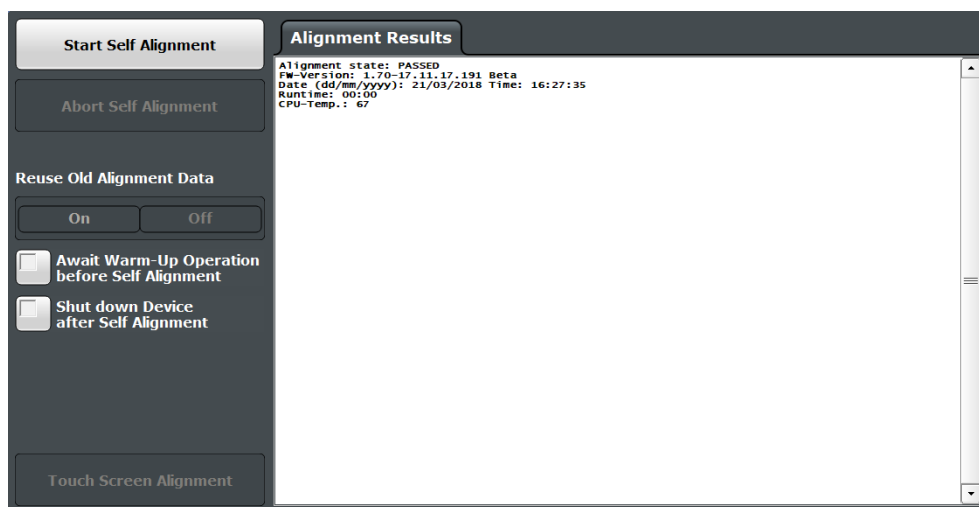

**Self-alignment results in secure user mode**

Be sure to store self-alignment results before [SecureUser Mode](#) is enabled; see [Chapter 2.7, "Protecting Data Using the Secure User Mode"](#), on page 37.

In secure user mode, the results are not stored permanently. Thus, if the currently stored self-alignment results are not suitable, you must perform a self-alignment each time you switch on the R&S ESW.

[Start Self Alignment](#) ..... 292

[Abort Self Alignment](#) ..... 292

[Await Warm-Up Operation before Self Alignment](#)..... 293

[Shut down Device after Self Alignment](#)..... 293

[Starting Touch Screen Alignment](#) ..... 293

[Alignment Results:](#) ..... 293

**Start Self Alignment**

Starts recording correction data for the instrument. If the correction data acquisition fails or if the correction values are deactivated, a corresponding message is displayed in the status field.

For details, see [Chapter 11.1.1, "Basics on Alignment"](#), on page 289.

**Note:**

A running Sequencer operation is aborted when you start a self-alignment.

Remote command:

\*CAL? on page 418, see also [CALibration\[:ALL\]?](#) on page 614

**Abort Self Alignment**

As long as the self-alignment data is being collected, the procedure can be canceled using the "Abort Self Alignment" button.

**Note:** If you start a self-alignment remotely, then select the "Local" softkey while the alignment is still running, the instrument only returns to the manual operation state after the alignment is completed. In this case, you cannot abort a self-alignment manually.

**Await Warm-Up Operation before Self Alignment**

Displays a message indicating the remaining warmup time required before self-alignment is performed. After the warmup operation has completed, self-alignment is started automatically.

**Shut down Device after Self Alignment**

If activated, the R&S ESW is automatically shut down after self-alignment is completed. Note that the instrument cannot be restarted via remote control.

**Starting Touch Screen Alignment**

Starts the touchscreen alignment.

Tap the 4 markers on the screen as you are asked to do. The touchscreen is aligned according to the executed pointing operations.

**Alignment Results:**

Information on whether the alignment was performed successfully and on the applied correction data is displayed. The results are available until the next self-alignment process is started or the instrument is switched off.

Remote command:

`CALibration:RESult?` on page 615

### 11.1.3 How to Perform a Self-Test

You do not have to repeat the self-test every time you switch on the instrument. It is only necessary when instrument malfunction is suspected.

**Operating temperature**

Before performing this functional test, make sure that the instrument has reached its operating temperature (for details, refer to the data sheet).

---

1. Press the [SETUP] key.
2. Press the "Service" softkey.
3. Press the "Selftest" softkey.

Once the instrument modules have been checked successfully, a message is displayed.

### 11.1.4 How to Align the Instrument

**Operating temperature**

Before performing this functional test, make sure that the instrument has reached its operating temperature (for details, refer to the data sheet).

---

**To perform a self-alignment**

1. Press the [SETUP] key.
2. Select the "Alignment" softkey.
3. Select the "Start Self Alignment" button.
4. To abort the self-alignment process, select the "Abort Self Alignment" button.

Once the system correction values have been calculated successfully, a message is displayed.



**To display the alignment results again later**

- Press the [SETUP] key.
- Press the "Alignment" softkey.

### 11.1.5 How to Align the Touchscreen

**To align the touchscreen**

1. Press the [Setup] key.
2. Select the "Alignment" softkey.
3. Select "Touch Screen Alignment" .  
A blinking cross appears in the lower left corner of the screen.
4. Touch and hold the blinking cross until it stops blinking.  
Repeat this action for the crosses in the other corners.

## 11.2 Display Settings

### 11.2.1 Display Settings

**Access:** [Setup] > "Display"

Some general display settings are available regardless of the current application or operating mode. For information on optimizing your display for measurement results, see [Chapter 9.1, "Result Display Configuration"](#), on page 182.

- [General Display Settings](#).....295
- [Displayed Items](#).....296
- [Display Theme and Colors](#).....299

### 11.2.1.1 General Display Settings

**Access:** [Setup] > "Display" > "General"

This section includes general screen display behavior and date and time display.

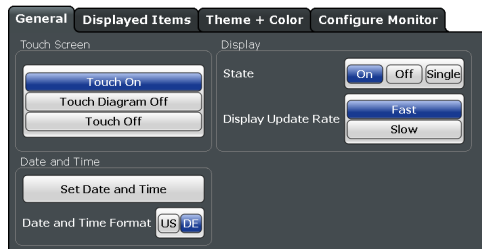

Deactivating and Activating the Touchscreen .....	295
Display Update Rate .....	295
Set Date and Time .....	295
Date and Time Format .....	295

#### Deactivating and Activating the Touchscreen

The touchscreen function can be deactivated, e.g. when the instrument is being used for demonstration purposes and tapping the screen must not provoke an action.

To reactivate the touchscreen, simply press the [Setup] key on the front panel. The "Display" dialog box is opened automatically and the "Touch Screen" option is set to "On" .

- "Touch On"            Touchscreen function is active for the entire screen.
- " Touch Off"        Touchscreen is deactivated for the entire screen.
- " Touch Diagram Off"
  - Touchscreen is deactivated for the diagram area of the screen, but active for the surrounding softkeys, toolbars and menus.

Remote command:

`DISPlay:TOUChscreen[:STATe]` on page 631

#### Display Update Rate

By default, a fast update rate ensures the most recent measurement results on the display. However, when performance is poor due to slow data transfer (for example during remote control), it can be helpful to decrease the frequency with which the screen display is updated.

#### Set Date and Time

The current date and time on the instrument is set using the standard Windows "Date and Time Properties" dialog box. Select the "Set Date and Time" button in the "Display" dialog box, or select the date and time display in the status bar to open the Windows dialog box.

#### Date and Time Format

Switches the time and date display on the screen between US and German (DE) format.

Remote command:

`DISPlay[:WINDow]:TIME:FORMat` on page 632

### 11.2.1.2 Displayed Items

**Access:** [Setup] > "Display" > "Displayed Items"

Several elements on the screen display can be hidden or shown as required, for example to enlarge the display area for the measurement results.

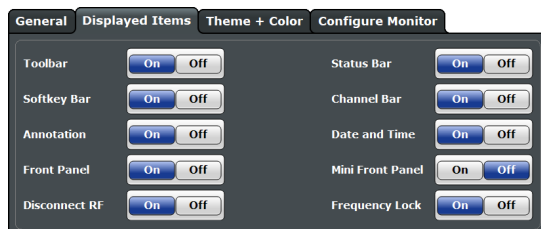

Toolbar .....	296
Status Bar .....	296
Softkey Bar .....	296
Channel Bar .....	297
Diagram Footer (Annotation) .....	297
Date and Time .....	297
Front Panel .....	297
Mini Front Panel .....	298
Lock Frequency.....	299
Disconnect RF .....	299

#### Toolbar

The toolbar provides access to frequently used functions via icons at the top of the screen. Some functions, such as zooming, finding help, printing screenshots or storing and loading files are not accessible at all without the toolbar.

Remote command:

`DISPlay:TBAR[:STATe]` on page 631

#### Status Bar

The status bar beneath the diagram indicates the global instrument settings, the instrument status and any irregularities during measurement or display.

Some of the information displayed in the status bar can be queried from the status registry via remote commands.

Remote command:

`DISPlay:SBAR[:STATe]` on page 631

#### Softkey Bar

Softkeys are virtual keys provided by the software. Thus, more functions can be provided than can be accessed directly via the function keys on the device.

The functions provided by the softkeys are often also available via dialog boxes. However, some functions are not accessible at all without the softkey bar.

**Note:** The softkey bar is hidden while the SmartGrid is displayed and restored automatically when the SmartGrid is closed.

Remote command:

`DISPlay:SKEYs[:STATe]` on page 631

### Channel Bar

The channel bar provides information on firmware and measurement settings for a specific channel.

Remote command:

`DISPlay:ANNotation:CBAR` on page 630

### Diagram Footer (Annotation)

The diagram footer beneath the diagram contains information on the x-axis of the diagram display, such as:

- The current center frequency and span settings
- The displayed span per division
- The number of sweep points

Remote command:

`DISPlay:ANNotation:FREQuency` on page 630

### Date and Time

The date and time display can be switched off independently of the status bar.

You can set the current date and time and configure the display format in the "General" tab of the "Display" dialog box.

Remote command:

`DISPlay[:WINDow]:TIME` on page 632

### Front Panel

The "Front Panel" display simulates the entire front panel of the device (except for the external connectors) on the screen. Thus, you can interact with the R&S ESW without the keypad and keys on the front panel of the device. That is useful, for example, when working with an external monitor or operating via remote control from a computer.





To activate or deactivate the front panel temporarily, press the [F6] key on the external keyboard (if available) or the remote computer.

For more information, see [Chapter 11.2.4, "How to Work with the Soft Front Panels"](#), on page 304.

Remote command:

`SYSTEM:DISPLAY:FPANEL[:STATE]` on page 633

### Mini Front Panel

If you require a front panel display but do not want to lose too much space for results in the display area, a mini front panel is available. The mini version displays only the main function keys in a separate window in the display area.

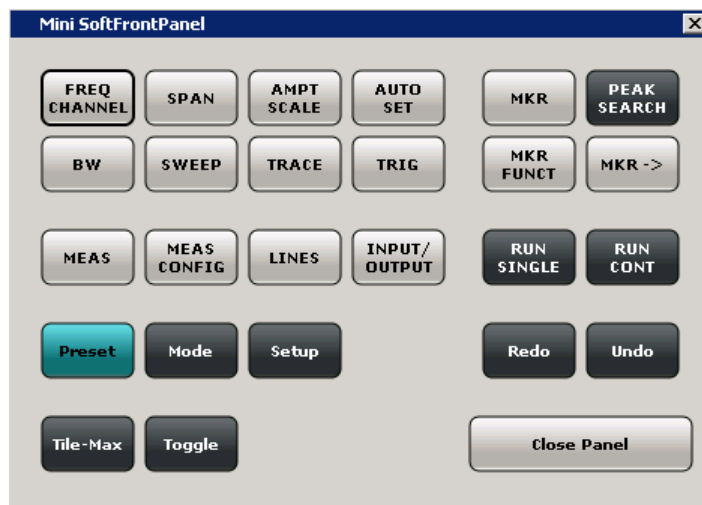
**Note:**

You can also activate the mini front panel using the key combination [ALT + m] (be aware of the keyboard language defined in the operating system!). That is useful when you are working from a remote PC and the front panel function is not active.

Remote command:

[SYSTem:DISPlay:FPANel\[:STATe\]](#) on page 633

**Lock Frequency**

Turns the display of the "Lock Frequency" icon in the toolbar on and off.

When the icon is part of the toolbar, you can turn the frequency lock on and off. When the lock is on, the frequency does not change when you turn the rotary knob.

Only applies to the frequency. You can still change other parameters with the rotary knob.

Remote command:

not supported

**Disconnect RF**

Turns the display of the "Disconnect RF" icon in the toolbar on and off.

When the icon is part of the toolbar, you can cut off the (external) signal fed into the RF input quickly and easily.

The disconnection applies to the currently selected RF input.

Remote command:

[DISPlay:ITERm\[:STATe\]](#) on page 630

[INPut:TERMinator](#) on page 632

**11.2.1.3 Display Theme and Colors**

**Access:** [Setup] > "Display" > "Theme + Color"

You can configure the used colors and styles of display elements on the screen.

For step-by-step instructions see [Chapter 11.2.3, "How to Configure the Colors for Display and Printing"](#), on page 303.

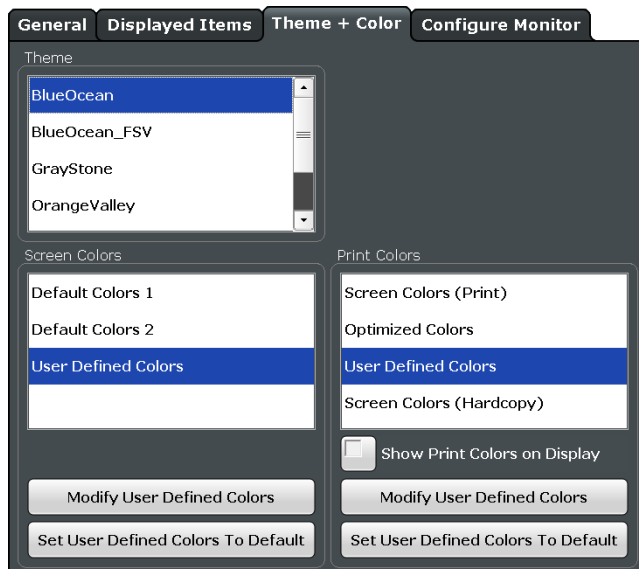

[Theme](#) ..... 300

[Screen Colors](#) ..... 300

[Print Colors](#) ..... 301

[Showing Print Colors on Display](#)..... 301

[Modifying User-Defined Color Assignments](#)..... 301

    L [Selecting the Object](#)..... 301

    L [Predefined Colors](#) ..... 302

    L [Preview](#) ..... 302

[Defining User-specific Colors](#)..... 302

[Restoring the User Settings to Default Colors](#)..... 302

**Theme**

The theme defines the colors and style used to display softkeys and other screen objects.

The default theme is "BlueOcean" .

Remote command:

`DISPlay:THEME:SElect` on page 635

**Screen Colors**

Two different color sets are provided by the <instrument>, a third user-defined set can be configured.

The default color schemes provide optimum visibility of all screen objects when regarding the screen from above or below. Default setting is "Default Colors 1" .

If "User Defined Colors" is selected, a user-defined color set can be defined (see ["Defining User-specific Colors"](#) on page 302).

Remote command:

`DISPlay:CMAP<item>:DEFault<colors>` on page 633

### Print Colors

Defines the color settings used for printout.

In addition to the predefined settings, a user-defined color set can be configured (see ["Defining User-specific Colors"](#) on page 302).

If "Show Print Colors on Display" is activated, the currently selected print colors are displayed as a preview for your selection.

Gui setting	Description	Remote command
"Optimized Colors"	Selects an optimized color setting for the printout to improve the visibility of the colors (default setting). Trace 1 is blue, trace 2 black, trace 3 green, and the markers are turquoise. The background is always printed in white and the grid in black.	HCOP:CMAP:DEF2
"Screen Colors (Print)"	Selects the current screen colors for the printout. The background is always printed in white and the grid in black.	HCOP:CMAP:DEF1
"Screen Colors (Screenshot)"	Selects the current screen colors without any changes for a screenshot.	HCOP:CMAP:DEF4
"User Defined Colors"	Selects the user-defined color setting.	HCOP:CMAP:DEF3

Remote command:

[HCOPY:CMAP<item>:DEFault<color>](#) on page 583

### Showing Print Colors on Display

Temporarily shows the currently selected print colors on the screen display. This function can be used as a preview for printing.

### Modifying User-Defined Color Assignments

You can configure the colors used to display and print individual screen objects according to your specific requirements.

The colors are configured in the (identical) "Screen Color Setup" / "Printer Color Setup" dialog boxes.

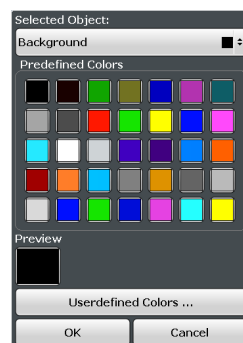

### Selecting the Object ← Modifying User-Defined Color Assignments

Selects the object for which the color is to be defined. Colors can be defined for the following objects:

- Background

- Grid
- Individual traces
- Display lines
- Limit lines and check results
- Markers and marker information

Remote command:

Each object is assigned to a specific suffix of the CMAP commands, see [Chapter 13.9.5.3, "CMAP Suffix Assignment"](#), on page 635.

### Predefined Colors ← Modifying User-Defined Color Assignments

Displays the available colors from the predefined color set that can be used for the selected object.

Remote command:

`HCOPY:CMAP<item>:PDEFined` on page 585

### Preview ← Modifying User-Defined Color Assignments

Indicates the currently selected color that will be used for the selected object.

### Defining User-specific Colors

In addition to the colors in the predefined color set you can configure a user-specific color to be used for the selected object.

When you select "Userdefined Colors..." , the set of predefined colors is replaced by a color palette and color configuration settings.



The color palette allows you to select the color directly. The color settings allow you to define values for tint, saturation and brightness.

Remote command:

`HCOPY:CMAP<item>:HSL` on page 584

### Restoring the User Settings to Default Colors

In addition to the predefined color settings, a user-defined setting can be configured. By default, the same settings as defined in "Default Colors 1" are used. They can then be modified according to user-specific requirements (see ["Modifying User-Defined Color Assignments"](#) on page 301).

The "Set to Default" function restores the original default settings for the user-defined color set. You can select which of the three default settings are restored.

Remote command:

DISPlay:CMAP<item>:PDEFined on page 634

### 11.2.2 External Monitor Settings

**Access:** [Setup] > "Display" > "Configure Monitor"

You can connect an external monitor (or projector) to the DVI or display port connector on the instrument's rear panel (see the R&S ESW getting started manual).



#### Screen resolution and format

The touchscreen of the R&S ESW is calibrated for a 16:10 format. If you connect a monitor or projector using a different format (e.g. 4:3), the calibration will not be correct and the screen will not react to your touch actions properly.

The touchscreen has a screen resolution of 1280x800 pixels. Most external monitors have a higher screen resolution. If the screen resolution of the monitor is set higher than the instrument's resolution, the application window uses an area of 1280x800 pixels on the monitor display. For full screen display, adjust the monitor's screen resolution.

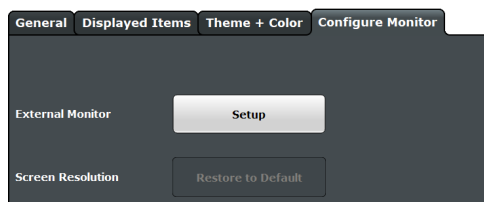

<a href="#">Setup</a> .....	303
<a href="#">Screen Resolution: Restore to Default</a> .....	303

#### Setup

Opens the standard Windows configuration dialog box to configure the used display devices.

#### Screen Resolution: Restore to Default

The default screen resolution (1280 x 800) is restored in the Windows configuration settings. This is useful, for instance, if the instrument was connected to a display device and was adapted to different requirements.

### 11.2.3 How to Configure the Colors for Display and Printing

You can configure the style and colors with which various screen objects are displayed or printed.

#### To select a color set

1. Press the [Setup] key and select the "Display" softkey.

2. Select the "Theme + Color" tab.
3. In the "Screen Colors" area, do one of the following:
  - Select a predefined set of colors for screen display.
  - Select "User Defined Colors" to configure the color set yourself.
4. In the "Print Colors" area, do one of the following:
  - Select a predefined set of colors for printing screenshots.
  - Select "User Defined Colors" to configure the color set yourself.
5. Activate the "Show Print Colors on Display" option to see a preview of the print colors.

#### To configure a user-defined color set



1. In the "Theme + Color" tab of the "Display" dialog box, select "User Defined Colors" either for the screen or the print colors.
2. Select "Modify User Defined Colors" .  
The "Screen Color Setup" dialog box is opened.
3. From the "Selected Object:" list, select the object to which you want to assign a color.
4. Do one of the following:
  - Select a color from the "Predefined Colors" .
  - Select the "Userdefined Colors ..." button to define a different color.  
The "Preview" area indicates the currently selected color.
5. To assign a user-specific color to the selected object, do one of the following:
  - Select the color from the palette.
  - Enter values for the "Tint:" , "Saturation:" , and "Brightness:" .  
**Note:** In the continuous color spectrum ( "Tint:" ), 0 % represents red and 100 % represents blue.
  - Enter an "ARGB:" value in hexadecimal format.
6. Select the next object to which you want to assign a color from the "Selected Object:" list.
7. Repeat these steps until you have assigned a color to all objects you want to configure.
8. Select "OK" to close the dialog box.  
The colors are applied to the assigned objects.

### 11.2.4 How to Work with the Soft Front Panels

Basic operation with the soft front panels is identical to normal operation, except for the following aspects:

To activate a key, select the key on the touchscreen.

To simulate the use of the rotary knob, use the additional keys displayed between the keypad and the arrow keys:

Icon	Function
	Turn left
	Enter
	Turn right

### Mini front panel

The mini front panel provides only the keys on the touchscreen, to operate the R&S ESW via an external monitor or remote desktop.

By default, the "Auto close" option is activated and the mini front panel window closes automatically after you select a key. This is useful if you only require the mini front panel display occasionally to press a single function key.

If you want the window to remain open, deactivate the "Auto close" option. You can close the window manually by selecting "Close panel" or the key combination [ALT + M] (be aware of the keyboard language defined in the operating system!).

### To display the soft front panel or mini front panel

1. Press the [Setup] key and select the "Display" softkey.
2. Select the "Displayed Items" tab.
3. Select "Front Panel" : "On" or "Mini Front Panel" : "On" .



To activate or deactivate the front panel temporarily, press the [F6] key on the external keyboard (if available) or on the remote computer.

## 11.3 Transducers

### 11.3.1 Transducer

Many EMC test setups contain a transducer (for example antennas, cables, probes or current probes). The transducer converts the interference variables like field strength, current or RFI voltage into a voltage across 50  $\Omega$ . Because most transducers have a characteristic frequency response, it is necessary to correct the measurement results by the frequency characteristics of the transducer. These characteristics are defined in a transducer factor or transducer sets.

The visible effect of a transducer is therefore a vertical shift of the results by the amount defined in the transducer factor for each frequency point.



### Transducer factors

A transducer factor takes the frequency response of a single transfer element into account. It consists of a series of reference values. Each reference value in turn consists of a frequency and the corresponding level (correction) value. The transducer factor can consist of up to 1001 reference values. Measurement points between the reference values are interpolated either linearly or logarithmically.

Note that the unit of the transducer overrides the unit you have selected for the measurement, because the R&S ESW is seen as the same device as the transducer itself. Measurement results are automatically converted into the unit of the transducer factor. Inputs are only possible in the unit of the transducer. If you want to have access to other units as well, the correction values must be defined in dB. When you turn off the transducer, the R&S ESW again uses the unit that was selected before.

Transducer factors are always applied to all active measurement windows.

### Transducer sets

A transducer set consists of several transducer factors and thus takes the frequency response of several transducers into account. Using transducer sets is recommended if you are using different transducers in the measurement range or if cable attenuation or an amplifier have to be considered.

If you are using a transducer set, you can divide the complete frequency range defined for the transducer set into 10 smaller frequency ranges. Make sure, however, that the ranges have no gaps in between each other. The stop frequency of one range must always be the start frequency of the next one.

You can assign up to eight transducer factors to each subrange. Make sure that the frequency range of a particular (sub)range is covered completely by the frequency range defined for the transducer factor. In addition, the unit of all transducer factors that are part of a set has to be the same (or, alternatively, "dB"). Transducer factors that do not meet this condition will not be available for selection.

If necessary, you can configure the R&S ESW to interrupt the scan when it reaches a range boundary. This interruption is called transducer break. While the scan is interrupted, exchange the transducer and continue the scan with the transducer factor assigned to the new range or turn off transducer use and continue the measurement without a transducer factor.

If the scan reaches a frequency not covered by the currently active transducer factor, the R&S ESW shows a message in status bar ("No valid transducer for current receiver frequency").

### Transducer management

The R&S ESW provides functionality to store and use the transducer factors during a measurement.

### Transducers in the receiver application

The transducer is calculated for a set scan. The transducer is uniquely calculated for each frequency point and added to the result of the level measurement as the measurement results are stored internally and can be zoomed later.

### Transducers in the spectrum application

The R&S ESW calculates the correction values defined in the transducer factor for every displayed measurement point before you start the measurement. During the measurement, it adds the correction values to the measurement results. If you change the frequency range of the measurement, the R&S ESW calculates the correction values again.

If several measured values are combined, only one value is considered.

## 11.3.2 Working with Transducers

The R&S ESW allows you to create or edit transducer factors and transducer sets. The corresponding functions are combined in a dialog box.

For more information about transducer factors in general, see [Chapter 11.3.1, "Transducer"](#), on page 305.



### Transducer settings in secure user mode

Be sure to store transducer files before [Secure User Mode](#) is enabled; see [Chapter 2.7, "Protecting Data Using the Secure User Mode"](#), on page 37.

- [Using Transducers](#)..... 307
- [Using an RF Switch](#)..... 311

### 11.3.2.1 Using Transducers

Access: [SETUP] > "Transducer"

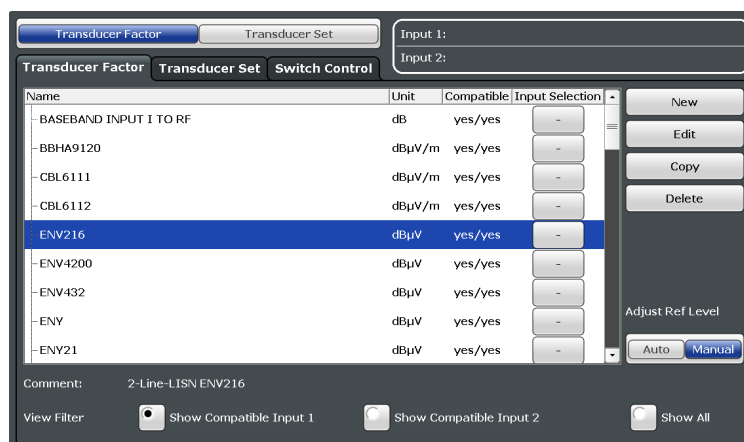

The dialog box contains several tabs, including one to configure transducer factors and one to configure transducer sets.

Basically, both tabs contain the following elements.

- A list of available transducer factors or transducer sets.  
The list shows the name of the transducer factor or set, its unit, if it is compatible with the current measurement configuration and its state.
- A button to filter the transducer factors that are displayed in the list (all factors or just the compatible ones).  
The filter is available for transducer factor selection.
- A line that shows the comment of a transducer factor or set.  
A comment is displayed only if one has been defined.
- Functions to create, edit and manage transducer factors and sets.

For more information about "Switch Control" , see [Chapter 11.3.2.2, "Using an RF Switch"](#), on page 311.



### Displaying transducer characteristics

In the Receiver application, you can use the "Transducer" [trace mode](#). Selecting this trace mode draws a trace that shows the correction values of all active transducers in the displayed frequency range.

<a href="#">Applying a transducer factor</a> .....	308
<a href="#">Designing and managing transducer factors</a> .....	309
<a href="#">Designing and managing transducer sets</a> .....	310

### Applying a transducer factor

The R&S ESW allows you to use either a transducer factor or a transducer set in a measurement. A combination of transducer factors and transducer sets is not possible.

A transducer factor or set becomes active when you assign it to one or both RF inputs. When you select one of the buttons in the "Input Selection" column of the transducer list, the R&S ESW opens a dialog box that allows you to select the input(s) that you want to apply the transducer to.

The R&S ESW shows if a transducer factor or set is active in a field at the top of the dialog box.

When the transducer factor is active, all amplitude settings and outputs take on the unit of the transducer factor. It is no longer possible to select another unit. An exception is in case the transducer has the unit dB.

The name of the active transducer is displayed in the channel bar and in the "Transducer" dialog box. To indicate the progress of the measurement, the diagram area also contains a green vertical line with the label "TF" .

Note that you can use up to eight transducer factors at the same time. If you want to use more transducer factors in the same measurement, you have to combine them in a transducer set.

### Dynamic range with active transducers

The shift of the trace caused by the transducer factor by a certain amount deteriorates the dynamic range of the measurement results.

To restore the original dynamic range, you have to compensate for the transducer factor. You can do this by adjusting the reference level accordingly. If you turn on the automatic adjustment of the reference level (→ "Adjust Ref Level" ), the R&S ESW restores the original dynamic range as best as possible by changing the reference level by the maximum level shift defined in the active transducer factor.

Remote command:

See [Chapter 13.9.4, "Transducers"](#), on page 618.

### Designing and managing transducer factors

Before you define the characteristics of a transducer factor, make sure that you have actually selected the tab to configure transducer factors.

You can configure a transducer factor in several ways:

- Edit a transducer factor that already exists (→ "Edit" ).
- Create a new transducer factor (→ "New" ).
- Create a new transducer factor based on an existing one (→ "Copy" ).

If necessary, you can delete the selected transducer factor at any time (→ "Delete" )

Each of the options opens the dialog box that contains the functionality to characterize a transducer factor.

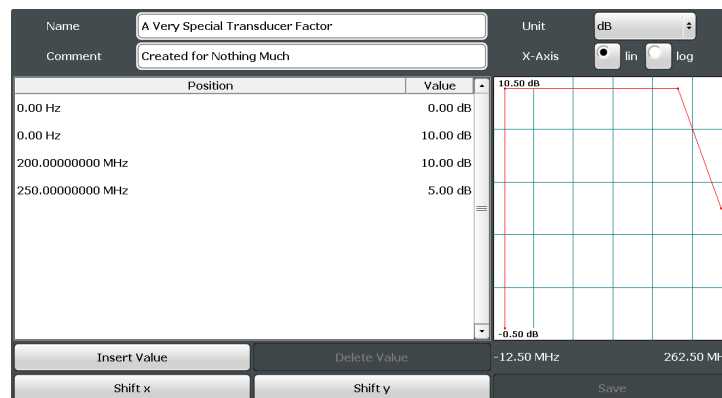

- "Name" / "Comment"  
Defines a name and / or comment of the transducer factor.
- "Unit"  
Selects the unit of the transducer factor.
- "X-Axis"  
Selects linear or logarithmic scaling of the x-axis.
- "Position" and "Value"  
Define the data points of the transducer factor (including a graphical preview).
- "Insert Value"  
Insert a transducer factor data point. Alternatively, you can click in the table itself to add a new data point.
- "Delete Value"  
Deletes the currently selected data point. The currently selected data point is highlighted blue.
- "Shift x" / "Shift y"  
Shifts all data points of the transducer factor horizontally or vertically by a certain amount.
- "Import" / "Export"

- Imports or exports the information for a transducer factor to or from a csv file.
- "Save"
  - Saves and stores the transducer factor on the internal hard disk of the R&S ESW.

A transducer factor can consist of up to 1001 data points. Each data point is a pair of values: the first value describes the frequency, the second value describes the level for that frequency.

You have to enter frequencies in ascending order. They must not overlap.

When you save the transducer factor, the R&S ESW uses the name of the transducer factor as the file name. The file type is \*.tdf. If a transducer factor of the same name already exists, the R&S ESW asks before it overwrites the existing file.

The transducer factors and sets are stored in separate but fix directories on the internal memory of the R&S ESW. You can create subdirectories for a more concise file structure and display their contents with the "Show Directories" softkey (you have to select the directory first, though).

In secure user mode, settings that are stored on the instrument are stored to volatile memory, which is restricted to 256 MB. Thus, a "memory limit reached" error can occur although the hard disk indicates that storage space is still available.

To store data permanently, select an external storage location such as a USB memory device.

For details, see [Chapter 2.7, "Protecting Data Using the Secure User Mode"](#), on page 37.

Remote command:

See [Chapter 13.9.4, "Transducers"](#), on page 618.

### Designing and managing transducer sets

Before you define the characteristics of a transducer set, make sure that you have actually selected the tab to configure transducer sets.

You can configure transducer sets in several ways:

- Edit a transducer set that already exists (→ "Edit" ).
- Create a new transducer set (→ "New" ).
- Create a new transducer set based on an existing one (→ "Copy" ).

If necessary, you can delete the selected transducer set at any time (→ "Delete" )

Each of the options opens the dialog box that contains the functionality to define a transducer set.

Range	Frequency	Factors
1	1.000 MHz	A Very Special Transducer Factor
	30.000 MHz	A Simple Factor
2	30.000 MHz	Another One
	1.000 GHz	

- "Name" / "Comment"  
Defines a name and / or comment of the transducer set.
- "Unit"  
Selects the unit of the transducer set.
- "Break"  
Turns the transducer break on and off.
- "Insert Range"  
Adds a new range to the transducer set. Each transducer set can consist of up to 10 ranges.  
To select a range, select the corresponding range in the table, or select it with the buttons on the bottom of the dialog box.
- "Delete Range"  
Deletes the currently selected transducer set range. The currently selected range is highlighted orange.
- "Start Frequency" / "Stop Frequency"  
Defines the start and stop frequencies for the selected transducer set range.
- "Add Factor"  
Opens a list of transducer factors that you can apply to the transducer set range. You can assign up to eight transducer factors to each range, but only those whose characteristics (frequency range, unit) are compatible to the characteristics of the selected range.
- "Change Factor"  
Replaces the selected transducer factor with another one. The selected transducer factor is highlighted.
- "Remove Factor"  
Removes the selected transducer factor from the transducer set range.
- "Save Sets"  
Saves and stores the transducer set on the internal hard disk of the R&S ESW.

In secure user mode, settings that are stored on the instrument are stored to volatile memory, which is restricted to 256 MB. Thus, a "memory limit reached" error can occur although the hard disk indicates that storage space is still available.

To store data permanently, select an external storage location such as a USB memory device.

For details, see [Chapter 2.7, "Protecting Data Using the Secure User Mode"](#), on page 37.

Remote command:

See [Chapter 13.9.4, "Transducers"](#), on page 618.

### 11.3.2.2 Using an RF Switch

An RF switch allows you to automatically route and condition RF signals as required from a single device in the test setup.

In the context of EMC measurements, using an RF switch can be useful for measurement scenarios in which you apply a transducer set (different transducers for different frequency ranges).

Without an RF switch, you would have to change the test setup and resume the measurement deliberately every time a new transducer has to be applied. With an RF

switch, however, you can prepare the complete setup in advance and program the RF switch matrix to switch automatically to a different signal path when a transducer break occurs (and the transducer properties change). Manual changes of the test setup during a measurement are no longer necessary.

- [Managing Datasets](#)..... 312
- [Programming a Switch Matrix](#)..... 313

**Managing Datasets**

**Access:** [SETUP] > "Transducer" > "Switch Control"

Information required to control an RF switch is stored in a dataset in the .xml file format.

This dataset is basically a program that remotely controls the RF switch to configure it for each transducer range. The dialog box to manage datasets is made up out of a table that shows all datasets available in the default directory of the R&S ESW or datasets that you have loaded from different file locations.

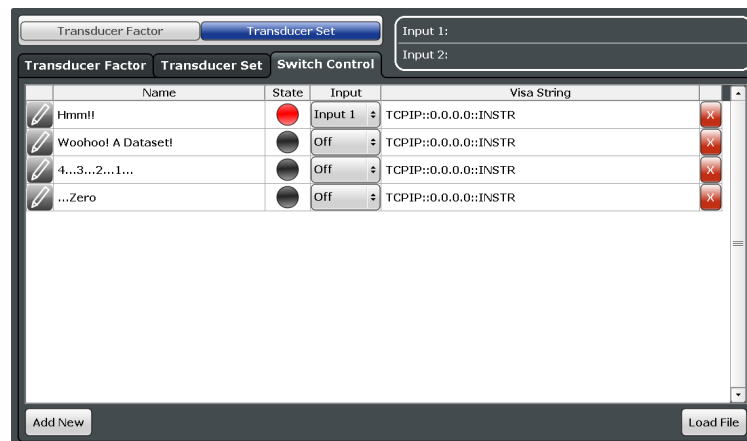

**Creating a dataset**

The "Add New" feature creates an empty dataset.

For more information about the corresponding dialog box, see "[Programming a Switch Matrix](#)" on page 313.

**Restoring a previously saved dataset**

The "Load File" feature restores a dataset that you have previously created (the dataset can also be on an external memory device).

After you have restored the dataset, it is added to the table.

**Working with the dataset table**

The table showing all available datasets contains the most relevant information about a dataset.

- Edit a dataset

The pencil icon in the first row opens a dialog box that allows you to change contents of a dataset.

For more information, see ["Programming a Switch Matrix"](#) on page 313.

- Edit the name of a dataset  
Changes [the name](#) of the dataset.
- Check the connection state  
The "State" column shows if an RF switch could be found on the selected RF input and on the network address defined in the corresponding dataset.  
When the RF input = OFF, the LED is always red.
- Select the RF input  
Selects the RF input the measurement is performed on.
- Define a network address  
Selects the [network address](#) of the RF switch.
- Delete a dataset  
The X icon in the last column deletes the corresponding dataset.

Remote commands:

Create a dataset: [\[SENSe:\]CORRection:SWITCh:SElect](#) on page 623

Select a dataset: [\[SENSe:\]CORRection:SWITCh:SElect](#) on page 623

Restore a dataset: [\[SENSe:\]CORRection:SWITCh:LOAD](#) on page 621

Delete a dataset: [\[SENSe:\]CORRection:SWITCh:DElete](#) on page 621

### Programming a Switch Matrix

**Access:** [SETUP] > "Transducer" > "Switch Control" > "Add New"

**Access:** [SETUP] > "Transducer" > "Switch Control" > "Edit" (pencil icon)

The RF switch is controlled by the R&S ESW with a set of remote commands that are saved in a dataset.

<a href="#">Defining dataset name and file name</a> .....	313
<a href="#">Connecting the R&amp;S ESW to the RF switch</a> .....	314
<a href="#">Selecting the RF input</a> .....	314
<a href="#">Controlling the RF switch</a> .....	314
L <a href="#">Synchronizing the command sequence</a> .....	315
L <a href="#">Defining a delay time</a> .....	315

### Defining dataset name and file name

The "Name" of the dataset is the name that is displayed in the dataset table.

When you save the dataset with the "Save to File" feature, you can select the location where the file is saved and a file name (which can be different to the dataset name).

When you close the dialog box with "Close" , the dataset is still saved, but is available only on the R&S ESW you have created it on (no file is created).

In addition, you can include a short "Comment" that contains additional information about the dataset.



Remote command:

Name: [\[SENSe:\]CORRection:SWITCh:NAME](#) on page 622

Select a dataset: [\[SENSe:\]CORRection:SWITCh:SELEct](#) on page 623

Save to file: [\[SENSe:\]CORRection:SWITCh:STORe](#) on page 623

Comment: [\[SENSe:\]CORRection:SWITCh:COMMeNt](#) on page 620

### Connecting the R&S ESW to the RF switch

Using an RF switch in the measurement requires you to establish a connection between the R&S ESW (as the controlling device) and the RF switch.

You can define the address of the RF switch in the "VISA string" input field. Depending on the type of connection / protocol (VXI-11, HiSlip and GPIB), make sure that the VISA string contains the correct prefix.

Example for VXI-11: `TCPIP::192.0.2.0::INSTR`

Example for HiSlip: `TCPIP::192.0.2.0::HISLIP`

Example for GPIB: `GPIB::20::INSTR`

Remote command:

[\[SENSe:\]CORRection:SWITCh:ADDReSS](#) on page 620

### Selecting the RF input

Selects the RF input of the R&S ESW used for the RF switch measurement.

When you run a measurement based on a certain dataset, the application assumes that the RF switch is connected to the selected input of the R&S ESW.

Remote command:

[\[SENSe:\]CORRection:SWITCh:INPut](#) on page 621

### Controlling the RF switch

The RF switch is controlled with a sequence of remote commands that you can define for each transducer range you have in the setup (represented by the 10 input fields in the dialog box).

You program the RF switch any way you want, with one or more commands per transducer range, as long as the command you are using is supported by the RF switch you are using. For a comprehensive description of supported commands, refer to the documentation of the RF switch.

If you are using more than one command, add all commands in one line, separated by a semicolon.

Each sequence of commands is sent to the RF switch when a transducer break occurs. This is the case when the measurement is done for a certain transducer range.

If necessary, you can send each command sequence deliberately with the "Send" buttons.

In addition to the commands for each transducer range, you can send an initial command ("Default") that is sent under the following circumstances:

- When you establish a connection to the RF switch.
- When you load a dataset.
- When you change the contents of the dataset.

You can use this default command, for example, to preset the RF switch.

**Command sets**

Most devices that you can control support commands that comply to the SCPI standard.

If you are using a device that does not support commands conform to the SCPI standard, turn off the "SCPI" property.

Remote command:

Default command: `[SENSe:]CORRection:SWITCh:DEFault[:COMManD]`

on page 620

Send default command: `[SENSe:]CORRection:SWITCh:DEFault:EXECute`

on page 621

Command set: `[SENSe:]CORRection:SWITCh:SCPI` on page 623

**Synchronizing the command sequence ← Controlling the RF switch**

Command synchronization makes sure that all commands in the sequence are finished before the next commands are sent.

When you turn on the "\*OPC?" property, the R&S ESW automatically synchronizes the command sequence for each transducer range.

Remote command:

`[SENSe:]CORRection:SWITCh:OPC` on page 622

**Defining a delay time ← Controlling the RF switch**

The "Delay" is a time period that the R&S ESW waits after each command sequence has been sent.

The delay is a useful tool to make sure that the operation that the last command does is done.

Remote command:

`[SENSe:]CORRection:SWITCh:WAIT` on page 624

**11.3.3 Reference: Transducer Factor File Format**

Transducer factor data can be exported to a file in ASCII (CSV) format for further evaluation in other applications. Transducer factors stored in the specified ASCII (CSV) format can also be imported to the R&S ESW for other measurements.

For more information about transducer factors, see "[Designing and managing transducer factors](#)" on page 309.

This reference describes in detail the format of the export/import files for transducer factors. Note that the **bold** data is **mandatory**, all other data is optional.

Different language versions of evaluation programs may require a different handling of the decimal point. Thus, you can define the decimal separator to be used (see "[Decimal Separator](#)" on page 204).

Table 11-1: ASCII file format for transducer factor files

File contents	Description
<b>Header data</b>	
sep=;	Separator for individual values (required by Microsoft Excel, for example)
Type;RS_TransducerFactor;	Type of data
FileFormatVersion;1.00;	File format version
Date;01.Oct 2006;	Date of data set storage
OptionID;SpectrumAnalyzer	Application the transducer factor was created for
Name;TestTDF1	Transducer factor name
Comment;Transducer for device A	Description of transducer factor
XAxisScaling;LINEAR	Scaling of x-axis linear (LIN) or logarithmic (LOG)
YAxisUnit;LEVEL_DB	Unit of y values
YAxisScaleMode;ABSOLUTE	Scaling of y-axis (absolute or relative)
NoOfPoints;5	Number of points the line is defined by
<b>Data section for individual data points</b>	
1000000000;-50.000000	<b>x- and y-values of each data point defining the line</b>
5000000000;-30.000000	
10000000000;0.000000	
15000000000;-30.000000	
25000000000;-50.000000	

### 11.3.4 How to Configure the Transducer

Configuring the transducer is very similar to configuring transducer factors.

The transducer settings are defined in the "Transducer" dialog box which is displayed when you press the [Setup] key and then select "Transducer" .



#### Stored transducer settings

When storing and recalling transducer settings, consider the information provided in "[Saving and recalling transducer and limit line settings](#)" on page 252.

The following tasks are described:

- "[How to find compatible transducer lines](#)" on page 317
- "[How to activate and deactivate a transducer](#)" on page 317
- "[How to edit existing transducer lines](#)" on page 317
- "[How to copy an existing transducer line](#)" on page 317
- "[How to delete an existing transducer line](#)" on page 318

- ["How to configure a new transducer line"](#) on page 318
- ["How to move the transducer line vertically or horizontally"](#) on page 318

#### How to find compatible transducer lines

- ▶ In the "Transducer" dialog box, select the "View Filter" option: "Show Compatible" . All transducer lines stored on the instrument that are compatible to the current measurement settings are displayed in the overview.

#### How to activate and deactivate a transducer

1. To activate a transducer select a transducer line in the overview and select the "Active" setting for it.  
The trace is automatically recalculated for the next sweep after a transducer line is activated.
2. To deactivate a transducer line, deactivate the "Active" setting for it.  
After the next sweep, the originally measured values are displayed.

#### How to edit existing transducer lines

Existing transducer line configurations can be edited.

1. In the "Transducer" dialog box, select the transducer line.
2. Select the "Edit" button.
3. Edit the line configuration as described in ["How to configure a new transducer line"](#) on page 318.
4. Save the new configuration by selecting the "Save" button.  
The trace is automatically recalculated for the next sweep if the transducer line is active.



In order to store the changes to the transducer lines in a settings file, select the  "Save" icon in the toolbar.

#### How to copy an existing transducer line

1. In the "Transducer" dialog box, select the transducer line.
2. Select the "Copy" button.  
The "Edit Transducer" dialog box is opened with the configuration of the selected transducer.
3. Define a new name to create a new transducer with the same configuration as the source line.
4. Edit the line configuration as described in ["How to configure a new transducer line"](#) on page 318.

5. Save the new configuration by selecting the "Save" button.

The new transducer line is displayed in the overview and can be activated.

#### How to delete an existing transducer line

1. In the "Transducer" dialog box, select the transducer line.
2. Select the "Delete" button.
3. Confirm the message.

The transducer line is deleted. After the next sweep, the originally measured values are displayed.

#### How to configure a new transducer line

1. In the "Transducer" dialog box, select the "New" button.

The "Edit Transducer" dialog box is displayed. The current line configuration is displayed in the preview area of the dialog box. The preview is updated after each change to the configuration.

2. Define a "Name" and, optionally, a "Comment" for the new transducer line.
3. Define the scaling for the x-axis.
4. Define the data points: minimum 2, maximum 1000:

- a) Select "Insert Value" .
- b) Define the x-value ( "Position" ) and y-value ( "Value" ) of the first data point.
- c) Select "Insert Value" again and define the second data point.
- d) Repeat this to insert all other data points.

To insert a data point before an existing one, select the data point and then "Insert Value" .

To insert a new data point at the end of the list, move the focus to the line after the last entry and then select "Insert Value" .

To delete a data point, select the entry and then "Delete Value" .

5. Check the current line configuration in the preview area of the dialog box. If necessary, correct individual data points or add or delete some.  
If necessary, shift the entire line vertically or horizontally by selecting the "Shift x" or "Shift y" button and defining the shift width.
6. Save the new configuration by selecting the "Save" button.

The new transducer line is displayed in the overview and can be activated.

#### How to move the transducer line vertically or horizontally

A configured transducer line can easily be moved vertically or horizontally. Thus, a new transducer line can be easily generated based upon an existing transducer line which has been shifted.

1. In the "Line Config" dialog box, select the transducer line.
2. Select the "Edit" button.

3. In the "Edit Transducer Line" dialog box, select the "Shift x" or "Shift y" button and define the shift width.
4. Save the shifted data points by selecting the "Save" button.  
If activated, the trace is recalculated after the next sweep.

#### How to export a transducer factor

Transducer factor configurations can be stored to an ASCII file for evaluation in other programs or to be imported later for other measurements.

1. In the "Edit Transducer" dialog box, select the transducer factor.
2. Select the "New" or "Edit" button.
3. Define the transducer factor as described in ["How to configure a new transducer line"](#) on page 318.
4. Select "Export" to save the configuration to a file.  
You are asked whether you would like to save the configuration internally on the R&S ESW first.
5. Select a file name and location for the transducer factor.
6. Select the decimal separator to be used in the file.
7. Select "Save" .

The transducer factor is stored to a file with the specified name and the extension .CSV.

For details on the file format see [Chapter 11.3.3, "Reference: Transducer Factor File Format"](#), on page 315.

#### How to import a transducer factor

Transducer factor configurations that are stored in an ASCII file and contain a minimum of required data can be imported to the R&S ESW.

For details on the required file format see [Chapter 11.3.3, "Reference: Transducer Factor File Format"](#), on page 315.

1. In the "Edit Transducer" dialog box, select the transducer factor.
2. Select the "New" or "Edit" button.
3. Select "Import" to load a transducer factor from a file.  
You are asked whether you would like to save the current configuration on the R&S ESW first.
4. Select the file name of the transducer factor.
5. Select the decimal separator that was used in the file.
6. Select "Select" .

The transducer factor is loaded from the specified file and displayed in the "Edit Transducer" dialog box.

7. Activate the transducer factor as described in "How to activate and deactivate a transducer" on page 317.

## 11.4 Reference Frequency Settings

Access: [Setup] > "Reference"

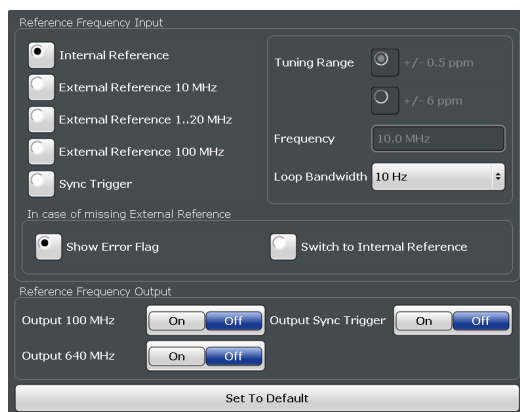

- Reference Frequency Input.....320
  - L Behavior in case of missing external reference..... 321
  - L Tuning Range..... 321
  - L Frequency..... 322
  - L Loop Bandwidth..... 322
- Reference Frequency Output..... 322
- Resetting the Default Values..... 322

### Reference Frequency Input

The R&S ESW can use the internal reference source or an external reference source as the frequency standard for all internal oscillators. A 10 MHz crystal oscillator is used as the internal reference source. In the external reference setting, all internal oscillators of the R&S ESW are synchronized to the external reference frequency.

External references are connected to one of the REF INPUT or the SYNC TRIGGER connectors on the rear panel. For details see the "Getting Started" manual.

**Note:** The optional, and more precise OCXO signal can replace the internal reference source.

The default setting is the internal reference. When an external reference is used, EXT REF is displayed in the status bar.

The following reference inputs are available:

**Table 11-2: Available Reference Frequency Input**

Source	Frequency	Tuning Range	Loop Bandwidth	Description
Internal	10 MHz	-	1-100 Hz	Internal reference signal or optional OCXO
External Reference 10 MHz	10 MHz	+/- 6 ppm	1-100 Hz	External reference from REF INPUT 1..20 MHz connector; Fixed external 10 MHz reference frequency. Good phase noise performance
External Reference 1..20 MHz	1..20 MHz in 1 Hz steps	+/- 0.5 ppm	0.1 Hz (fixed)	Variable external reference frequency in 1 Hz steps from REF INPUT 1..20 MHz connector; Good external phase noise suppression. Small tuning range.
		+/- 6 ppm	1-30 Hz	Variable external reference frequency in 1 Hz steps from REF INPUT 1..20 MHz connector; Wide tuning range.
External Reference 100 MHz	100 MHz	+/- 6 ppm	1-300 Hz	External reference from REF INPUT 100 MHz connector Good phase noise performance
Sync Trigger	100 MHz	+/- 6 ppm	1-300 Hz	External reference from SYNC TRIGGER INPUT connector

Remote command:

[\[SENSe:\]ROSCillator:SOURce](#) on page 612

[SOURce:EXternal:ROSCillator:EXternal:FREQuency](#) on page 612

#### **Behavior in case of missing external reference ← Reference Frequency Input**

If an external reference is selected but none is available, there are different ways the instrument can react.

"Show Error Flag"      The error message "External reference missing" is displayed if no valid external reference signal is available. Additionally, the flag "NO REF" is displayed to indicate that no synchronization was performed *for the last measurement*.

"Switch to internal reference"      The instrument automatically switches back to the internal reference if no external reference is available. Note that you must re-activate the external reference if it becomes available again at a later time.

Remote command:

[\[SENSe:\]ROSCillator:SOURce](#) on page 612

[\[SENSe:\]ROSCillator:SOURce:EAUTO?](#) on page 613

#### **Tuning Range ← Reference Frequency Input**

The tuning range is only available for the variable external reference frequency. It determines how far the frequency may deviate from the defined level in parts per million ( $10^{-6}$ ).



- " $\pm 0.5$  ppm" With this smaller deviation a very narrow fixed loop bandwidth of 0.1 Hz is realized. With this setting the instrument can synchronize to an external reference signal with a very precise frequency. Due to the very narrow loop bandwidth, unwanted noise or spurious components on the external reference input signal are strongly attenuated. Furthermore, the loop requires about 30 seconds to reach a locked state. During this locking process, "NO REF" is displayed in the status bar.
- " $\pm 6$  ppm" The larger deviation allows the instrument to synchronize to less precise external reference input signals.

Remote command:

[\[SENSe:\]ROSCillator:TRANge](#) on page 614

### Frequency ← Reference Frequency Input

Defines the external reference frequency to be used (for variable connectors only).

### Loop Bandwidth ← Reference Frequency Input

Defines the speed of internal synchronization with the reference frequency. The setting requires a compromise between performance and increasing phase noise.

For a variable external reference frequency with a narrow tuning range ( $\pm 0.5$  ppm), the loop bandwidth is fixed to 0.1 Hz and cannot be changed.

Remote command:

[\[SENSe:\]ROSCillator:LBWidth](#) on page 611

### Reference Frequency Output

A reference frequency can be provided by the R&S ESW to other devices that are connected to this instrument. If activated, the reference signal is output to the corresponding connector.

"Output 100 MHz"

Provides a 100 MHz reference signal to the REF INPUT 100 MHz connector.

"Output 640 MHz"

Provides a 640 MHz reference signal to the REF OUTPUT 640 MHz connector.

"Output Sync Trigger"

Provides a 100 MHz reference signal to the SYNC TRIGGER OUTPUT connector.

Remote command:

[\[SENSe:\]ROSCillator:O100](#) on page 611

[\[SENSe:\]ROSCillator:O640](#) on page 612

[\[SENSe:\]ROSCillator:OSYNc](#) on page 612

### Resetting the Default Values

The values for the "Tuning Range", "Frequency" and "Loop Bandwidth" are stored for each source of "Reference Frequency Input".

When you switch the input source, the previously defined settings are restored. You can restore the default values for all input sources using the "Preset Channel" function.

## 11.5 System Configuration Settings

**Access:** [Setup] > "System Configuration"

- [Hardware Information](#).....323
- [Information on Versions and Options](#).....323
- [System Messages](#).....325
- [Firmware Updates](#).....325
- [General Configuration Settings](#).....327

### 11.5.1 Hardware Information

**Access:** [Setup] > "System Configuration" > "Hardware Info"

An overview of the installed hardware in your R&S ESW is provided.

Every listed component is described by its serial number, order number, model information, hardware code, and hardware revision.

This information can be useful when problems occur with the instrument and you require support from Rohde & Schwarz.

COMPONENT	SERIAL #	ORDER #	MODEL	HWC	REV
FRONTEND BOARD					
DIGITAL MOTHERBOARD					
DETECTOR BOARD					
MICROWAVE CONVERTER BASE BOARD					
MICROWAVE CONVERTER FRONTEND UNIT					
RF ATTENUATOR					
RF PREAMPLIFIER BOARD					
SYNTHESIZER BOARD					
REFERENCE BOARD					
OXCX					
FRONTPANEL BOARD					
DETECTOR EXTENSION BOARD, REV. 2					
PRESELECTOR 1					
PRESELECTOR 2					
EXTERNAL GENERATOR CONTROL BOARD					
CPU BOARD - SIM					
DEFAULT IDENTITY					
...					

**Remote command:**

[DIAGnostic:SERVICE:HWInfo?](#) on page 657

### 11.5.2 Information on Versions and Options

**Access:** [Setup] > "System Configuration" > "Versions + Options"

Information on the firmware version and options installed on your instrument is provided. The unique Rohde & Schwarz device ID is also indicated here, as it is required for license and option administration.

You can also install new firmware options in this dialog box.

The table also contains:

- The open source acknowledgements (PDF file) for the firmware and other software packages used by the R&S ESW



**Installing options in secure user mode**

Be sure to install any new options before [SecureUser Mode](#) is enabled; see [Chapter 2.7, "Protecting Data Using the Secure User Mode"](#), on page 37.

For restricted users in secure user mode, this function is not available!



**Expired option licenses**

If an option is about to expire, a message box is displayed to inform you. You can then use the "Install Option" function to enter a new license key.

If an option has already expired, a message box appears for you to confirm. In this case, all instrument functions are unavailable (including remote control) until the R&S ESW is rebooted. You must then use the "Install Option" function to enter the new license key.

Item	Option	Version	License
R&S Device ID			
Instrument Firmware			
BIOS		47.11- SIM	
Image		0.0.0	
Device Installation		0.0.0	
PCIE-FPGA		8.03	
SA-FPGA		10.05	
RTSA-FPGA-B160RA		13.13	
RTSA-FPGA-NRT		16.04	
MB-FPGA		0.0.0.0	
SYNTH-FPGA		0.0.0.0	
REF-FPGA		0.0.0.0	
MWC-FPGA		0.0.0.0	
Data Sheet		01.00	
Time Control Management			active
Smart Card Service			installed

Install Option
Install Option by XML

For details on options refer to the "Getting Started" manual, "Checking the Supplied Items".

**Remote commands:**

[SYSTem:FORMat:IDENT](#) on page 660

[DIAGnostic:SERvice:BIOSinfo?](#) on page 657

[DIAGnostic:SERvice:VERSinfo?](#) on page 658

**Open Source Acknowledgment: Open**

Displays a PDF file containing information on open source code used by the R&S ESW firmware.

**Install Option**

Opens an edit dialog box to enter the license key for the option that you want to install.

Only user accounts with administrator rights are able to install options.

**Install Option by XML**

Opens a file selection dialog box to install an additional option to the R&S ESW using an XML file. Enter or browse for the name of an XML file that contains the option key and select "Select".

Only user accounts with administrator rights are able to install options.

**11.5.3 System Messages**

**Access:** [Setup] > "System Configuration" > "System Messages"

The system messages generated by the R&S ESW are displayed.

The messages are displayed in the order of their occurrence; the most recent messages are placed at the top of the list. Messages that have occurred since you last visited the system messages tab are marked with an asterisk '\*'.

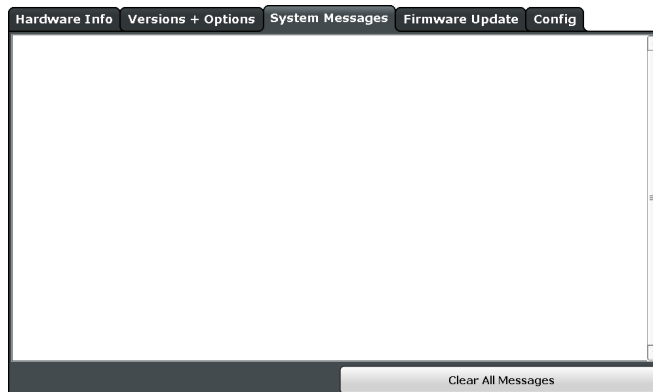

If the number of error messages exceeds the capacity of the error buffer, "Message Buffer Overflow" is displayed. To clear the message buffer use the "Clear All Messages" button.

The following information is available:

No	device-specific error code
Message	brief description of the message
Component	hardware messages: name of the affected module
	software messages: name of the affected software
Date/Time	date and time of the occurrence of the message

**Remote command:**

`SYSTem:ERRor:LIST?` on page 659

**11.5.4 Firmware Updates**

**Access:** [Setup] > "System Configuration" > "Firmware Update"

During instrument start, the installed hardware is checked against the current firmware version to ensure the hardware is supported. If not, an error message is displayed ( "Wrong Firmware Version" ) and you are asked to update the firmware. Until the firmware version is updated, self-alignment fails. To see which components are not supported, see the [System Messages](#).

The firmware on your R&S ESW may also need to be updated in order to enable additional new features or if reasons for improvement come up. Ask your sales representative or check the Rohde&Schwarz website for availability of firmware updates. A firmware update package includes at least a setup file and release notes.



Before updating the firmware on your instrument, read the release notes delivered with the firmware version.



### Installing options in secure user mode

Be sure to perform any firmware updates before [SecureUser Mode](#) is enabled; see [Chapter 2.7, "Protecting Data Using the Secure User Mode"](#), on page 37.

For restricted users in secure user mode, this function is not available!

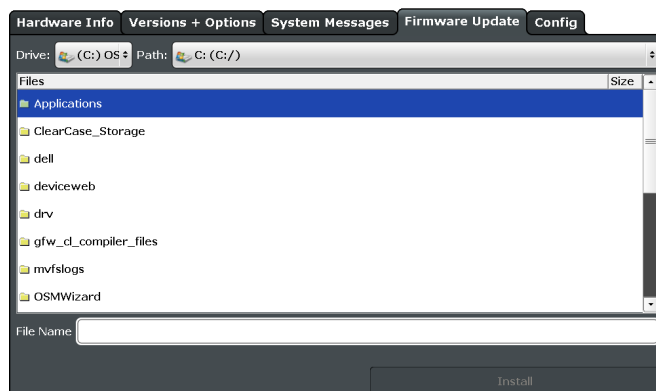

Enter the name or browse for the firmware installation file and press the "Install" button.

### Remote command:

`SYSTEM:FIRMWARE:UPDATE` on page 660

### How to Update the Instrument Firmware

1. Download the update package from the Rohde&Schwarz website and store it on a memory stick, on the instrument, or on a server network drive that can be accessed by the instrument.
2. **NOTICE!** Stop measurement. The firmware update must not be performed during a running measurement.  
If a measurement is running, stop it by pressing the highlighted [Run Cont] or [Run Single] key.

3. Select the [Setup] key.
4. Select the "System Config" softkey.
5. Select the "Firmware Update" tab.
6. In the file selection dialog box select the ESWSetup\*.exe file.
7. Select "Install" to start the update.
8. After the firmware update, the R&S ESW reboots automatically.
9. Depending on the previous firmware version, a reconfiguration of the hardware might be required during the first startup of the firmware. The reconfiguration starts automatically, and a message box informs you about the process. When the reconfiguration has finished, the instrument again reboots automatically.

**Note:** Do not switch off the instrument during the reconfiguration process!

Now the firmware update is complete.

It is recommended that you perform a self-alignment after the update (see [Chapter 11.1.4, "How to Align the Instrument"](#), on page 293).

### 11.5.5 General Configuration Settings

**Access:** [Setup] > "System Configuration" > "Config"

General system settings, for example concerning the initial behaviour of the R&S ESW after booting, can also be configured.

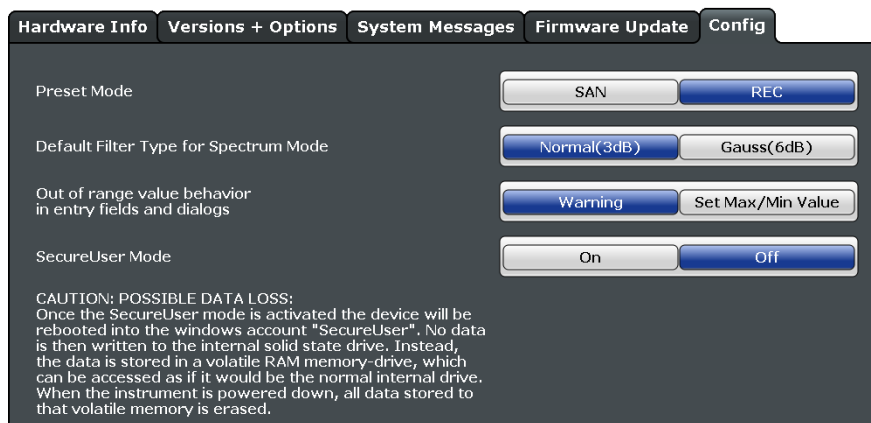

<a href="#">Preset Mode</a> .....	327
<a href="#">Default Filter Type for Spectrum Mode</a> .....	328
<a href="#">Out-of-range value behavior</a> .....	328
<a href="#">SecureUser Mode</a> .....	328
L <a href="#">Changing the password</a> .....	328

#### Preset Mode

The preset mode selects the application that is started after an instrument preset.

The presettings can be defined in the "Config" tab of the "System Configuration" dialog box.

For details on operating modes see [Chapter 6, "Applications"](#), on page 81.

"SAN" Signal and Spectrum Analyzer mode

"REC" Receiver application

Remote command:

`SYSTem:PRESet:COMPAtible` on page 661

#### Default Filter Type for Spectrum Mode

Selects the type of resolution filter that is selected after a preset in the spectrum application.

"Normal (3 dB)" Selects 3 dB filter.

"Gauss (6 dB)" Selects 6 dB filter.  
Note that in the receiver application, the default filter is always the 6 dB filter.

Remote command:

`SYSTem:PRESet:FILTer` on page 661

#### Out-of-range value behavior

By default, if you enter a value that is outside the valid range in an input field for a setting, a warning is displayed and the value is not accepted. Alternatively, entries below the minimum value can automatically be set to the minimum possible entry, and entries above the maximum value set to the maximum possible entry. This behavior avoids errors and facilitates setting correct values.

#### SecureUser Mode

If activated, the R&S ESW requires a reboot and then automatically logs in using the "SecureUser" account.

Data that the R&S ESW normally stores on the solid-state drive is redirected to volatile memory instead. Data that is stored in volatile memory can be accessed by the user during the current instrument session; however, when the instrument's power is removed, all data in volatile memory is erased.

The Secure User Mode can only be activated or deactivated by a user with administrator rights.

**Note:** Storing instrument settings permanently. Before you activate secure user mode, store any instrument settings that are required beyond the current session, such as predefined instrument settings, transducer files, or self-alignment data.

For details on the secure user mode see [Chapter 2.7, "Protecting Data Using the Secure User Mode"](#), on page 37.

Remote command:

`SYSTem:SECurity[:STATe]` on page 661

**Note:** Initially after installation of the R&S ESW-K33 option, secure user mode must be enabled manually once before remote control is possible.

#### Changing the password ← SecureUser Mode

When the secure user mode is activated the first time after installation, you are prompted to change the passwords for all user accounts in order to improve system security.



To save the new password, select "Save" . The password dialog for the next user is displayed, until you have been prompted to change the password all user accounts.

If you cancel the dialog without changing the password, the password dialog for the next user is displayed, until you have been prompted to change the password all user accounts. Although it is possible to continue in secure user mode without changing the passwords (and you will not be prompted to do so again), it is strongly recommended that you do define a more secure password for all users.

By default, the password characters are not displayed to ensure confidentiality during input. To display the characters, select "Show password" .

To display the onscreen keyboard, select "Keyboard" .

## 11.6 Service Functions

**Access:** [Setup] > "Service"

When unexpected problems arise with the R&S ESW some service functions may help you solve them.

- [R&S Support Information](#)..... 329
- [Self-test Settings and Results](#)..... 330
- [Calibration Signal Display](#)..... 331
- [Service Functions](#)..... 332
- [Hardware Diagnostics](#)..... 334

### 11.6.1 R&S Support Information

**Access:** [Setup] > "Service" > "R&S Support"

In case of errors you can store useful information for troubleshooting and send it to your Rohde & Schwarz support center.



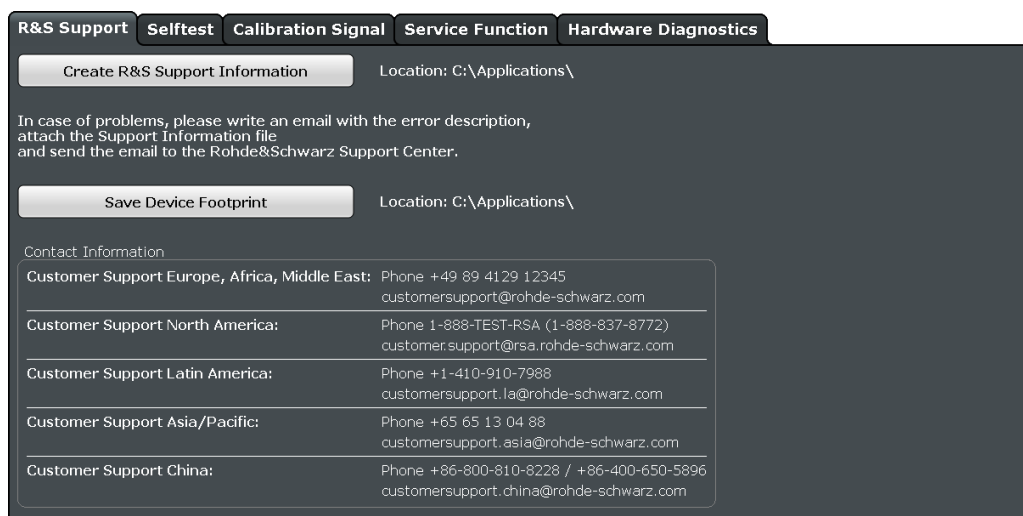

Create R&S Support Information ..... 330  
 Save Device Footprint ..... 330

**Create R&S Support Information**

Creates a \*.zip file with important support information. The \*.zip file contains the system configuration information ( "Device Footprint" ), the current eeprom data and a screenshot of the screen display.

This data is stored to the C:\R\_S\Instr\User directory on the instrument.

The file name consists of the unique device ID and the current date and time of the file creation.

If you contact the Rohde&Schwarz support to get help for a certain problem, send these files to the support in order to identify and solve the problem faster.

Remote command:

[DIAGnostic:SERvice:SINFo?](#) on page 663

**Save Device Footprint**

Creates an \*.xml file with information on installed hardware, software, image and FPGA versions. The \*.xml file is stored under

C:\Program Files (x86)\Rohde-Schwarz\ESW\<version>\devicedata\xml\ on the instrument. It is also included in the service.zip file.

**11.6.2 Self-test Settings and Results**

**Access:** [Setup] > "Service" > "Selftest"

If the R&S ESW fails you can perform a self-test of the instrument to identify any defective modules.

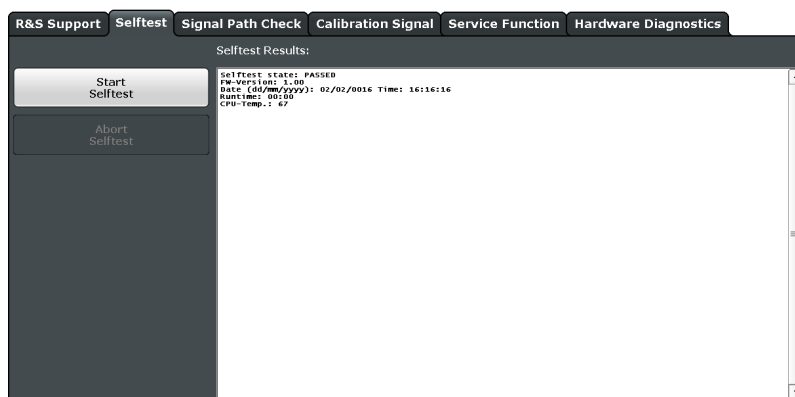

Once the self-test is started, all modules are checked consecutively and the test result is displayed. You can abort a running test.

In case of failure a short description of the failed test, the defective module, the associated value range and the corresponding test results are indicated.



A running Sequencer process is aborted when you start a self-test. If you start a self-test remotely, then select the "Local" softkey while the test is still running, the instrument only returns to the manual operation state after the test is completed. In this case, the self-test cannot be aborted.

**Remote command:**

\*TST? on page 421

DIAGnostic:SERVICE:STEST:RESult? on page 617

### 11.6.3 Calibration Signal Display

**Access:** [Setup] > "Service" > "Calibration Signal"

Alternatively to the RF input signal from the front panel connector you can use the instrument's calibration signal as the input signal, for example to perform service functions on.

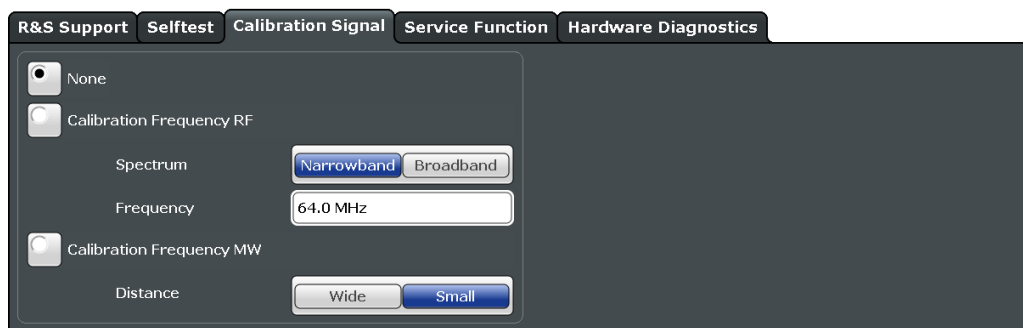

NONE .....	332
Calibration Frequency RF .....	332
L Spectrum .....	332
L Frequency .....	332
Calibration Frequency MW .....	332

**NONE**

Uses the current RF signal at the input, i.e. no calibration signal (default).

Remote command:

`DIAGnostic:SERVice:INPut[:SElect]` on page 616

**Calibration Frequency RF**

Uses the internal calibration signal as the RF input signal.

Remote command:

`DIAGnostic:SERVice:INPut[:SElect]` on page 616

`DIAGnostic:SERVice:INPut:PULSed:CFrequency` on page 615

**Spectrum ← Calibration Frequency RF**

Defines whether a broadband or narrowband calibration signal is sent to the RF input.

"Narrowband" Used to calibrate the absolute level of the frontend at 64 MHz.

"Broadband" Used to calibrate the IF filter.

Remote command:

`DIAGnostic:SERVice:INPut:RF[:SPECTrum]` on page 616

**Frequency ← Calibration Frequency RF**

Defines the frequency of the internal broadband calibration signal to be used for IF filter calibration (max. 64 MHz).

For narrowband signals, 64 MHz is sent.

**Calibration Frequency MW**

Uses the microwave calibration signal as the RF input (for frequencies greater than 8 GHz). This function is used to calibrate the YIG-filter on the microwave converter. The microwave calibration signal is pulsed. You can define whether the distance between input pulses is small or wide.

Remote command:

`DIAGnostic:SERVice:INPut[:SElect]` on page 616

**11.6.4 Service Functions**

**Access:** [Setup] > "Service" > "Service Function"

**NOTICE**

**Using service functions**

The service functions are not necessary for normal measurement operation. Incorrect use can affect correct operation and/or data integrity of the R&S ESW.

Therefore, only user accounts with administrator rights can use service functions and many of the functions can only be used after entering a password. These functions are described in the instrument service manual.

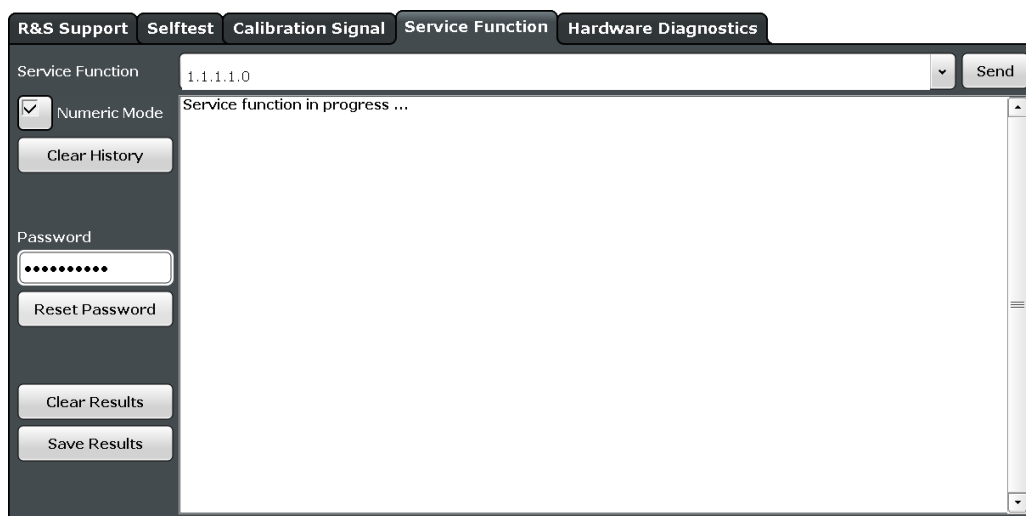

Service Function ..... 333  
 Send ..... 333  
 Numeric Mode ..... 334  
 Clear History ..... 334  
 Password ..... 334  
 Clear Results ..... 334  
 Save Results ..... 334  
 Result List ..... 334

**Service Function**

Selects the service function by its numeric code or textual name.

The selection list includes all functions previously selected (since the last "Clear History" action).

Remote command:

[DIAGnostic:SERvice:SFUNction](#) on page 662

**Send**

Starts the selected service function.

Remote command:

[DIAGnostic:SERvice:SFUNction](#) on page 662

**Numeric Mode**

If activated, the service function is selected by its numeric code. Otherwise, the function is selected by its textual name.

**Clear History**

Deletes the list of previously selected service functions.

**Password**

Most service functions require a special password as they may disrupt normal operation of the R&S ESW. There are different levels of service functions, depending on how restrictive their use is handled. Each service level has a different password.

"Reset Password" clears any previously entered password and returns to the most restrictive service level.

Remote command:

[SYSTem:PASSword\[:CENable\]](#) on page 664

[SYSTem:PASSword:RESet](#) on page 664

**Clear Results**

Clears the result display for all previously performed service functions.

Remote command:

[DIAGnostic:SERVice:SFUNction:RESults:DELeTe](#) on page 663

**Save Results**

Opens a file selection dialog box to save the results of all previously performed service functions to a file.

Remote command:

[DIAGnostic:SERVice:SFUNction:RESults:SAVE](#) on page 663

**Result List**

The Results List indicates the status and results of the executed service functions.

## 11.6.5 Hardware Diagnostics

In case problems occur with the instrument hardware, some diagnostic tools provide information that may support troubleshooting.

The hardware diagnostics tools are available in the "Hardware Diagnostics" tab of the "Service" dialog box.

Relays Cycle Counter	
Type	Counter
Preselector 1 PRESEL	7
Preselector 2 EXT_RELAIS	7
Preselector 1 RFAB	3
Preselector 1 PREAMP30MHZ	2
Preselector 1 ATTINPUT2	2
Preselector 1 INPUT2	1
Mechanical Attenuation 5 dB	0
Mechanical Attenuation 10 dB	0
Mechanical Attenuation 20 dB	0
Mechanical Attenuation 40 dB	0
Calibration Source	0
AC/DC-Coupling	0
Preamplifier	0

Relays Cycle Counter ..... 335

**Relays Cycle Counter**

The hardware relays built into the R&S ESW may fail after a large number of switching cycles (see data sheet). The counter indicates how many switching cycles the individual relays have performed since they were installed.

Remote command:

[DIAGnostic:INFO:CCOut?](#) on page 657

## 11.7 Synchronizing Measurement Channel Configuration

**Access:** [SETUP] > "Parameter Coupling"

Each of the applications of the R&S ESW is usually treated as an independent entity regarding their configuration: changing a setting in one measurement channel does not automatically change the corresponding setting in another channel.

For example, changing the frequency in the receiver application does not, by default, change the frequency in the spectrum application.

However, sharing settings can be convenient for certain measurement tasks. The R&S ESW provides a tool to couple (or synchronize) selected parameters across applications - the coupling manager.

- [General Parameter Coupling](#)..... 335
- [Using the Custom Coupling Manager](#)..... 338
- [Example for a User-Defined Parameter Coupling](#).....341

### 11.7.1 General Parameter Coupling

**Access:** [SETUP] > "Parameter Coupling" > "General"

The "General" tab of the coupling manager contains several parameters that you can couple across all (active) measurement channels - if the channel supports the corresponding parameter.

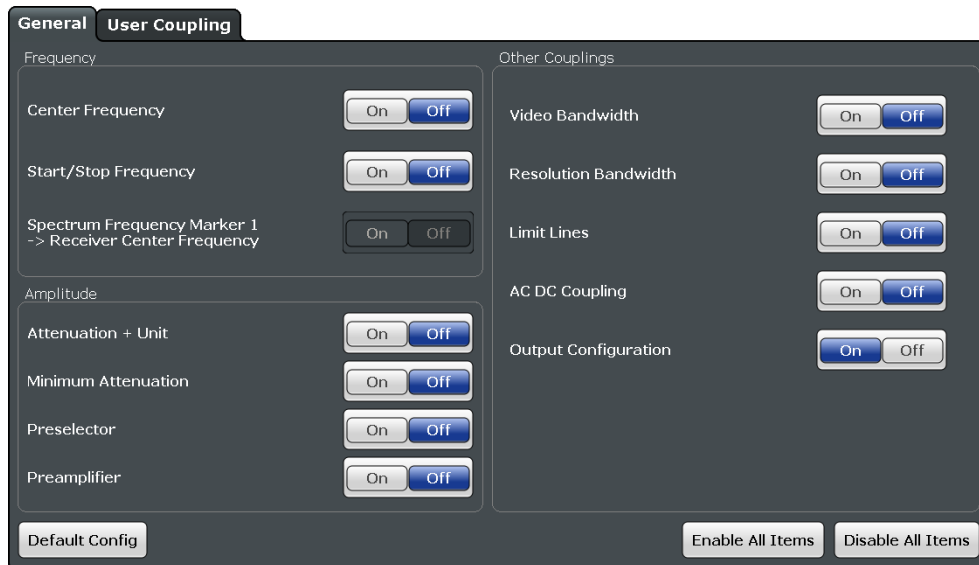

When you couple a parameter across all active measurement channels, a change in the currently selected application is passed on to all other active measurement channels.

**Example:**

You have opened one instance of the spectrum application, two instances of the receiver application and one instance of the analog demodulation application. The currently selected channel is the first receiver channel (as shown in the picture).



When you turn the coupling of the frequency on, changing the frequency in the "Receiver" channel also changes the frequency in the "Spectrum", "Receiver 2" and "Analog Demod" channels.

[Synchronizing parameters across all measurement channels](#)..... 336

[Selecting all or no coupling mechanisms](#)..... 338

[Restoring the default configuration](#)..... 338

**Synchronizing parameters across all measurement channels**

To synchronize a specific parameter, turn on the corresponding function.

## Synchronizing Measurement Channel Configuration

Coupling	Effect when turned on
"Center Frequency"	Synchronizes the (center / receiver) frequency Remote command: <code>INSTRument:COUPle:CENTer</code> on page 638
"Start / Stop Frequency"	Synchronizes the start and stop frequencies for measurements in the frequency domain. <b>Note:</b> The start and stop frequencies can automatically change when you change another frequency parameter (like center frequency or span). Remote command: <code>INSTRument:COUPle:SPAN</code> on page 641
"Marker → Frequency"	Synchronizes the receiver frequency in the receiver application with the frequency of marker 1 in the spectrum application. <b>Note:</b> Simultaneous synchronization of center frequency, start and stop frequency and synchronization of marker and center frequency is not possible. Remote command: <code>INSTRument:COUPle:MARKer</code> on page 640
"Attenuation + Unit"	Synchronizes the attenuation and the unit of the level axis. Remote command: <code>INSTRument:COUPle:ATTen</code> on page 638
"Minimum Attenuation"	Synchronizes the <b>10 dB Minimum Attenuation</b> feature. Remote command: <code>INSTRument:COUPle:PROT</code> on page 640
"Preamplifier"	Synchronizes the gain of the optional preamplifier. <b>Note:</b> If you have selected automatic selection of the ideal gain in a receiver application, only the calculated gain value is synchronized. Remote command: <code>INSTRument:COUPle:GAIN</code> on page 639
"Resolution Bandwidth"	Synchronizes the measurement bandwidth. <b>Note:</b> Simultaneous synchronization of the video bandwidth and the resolution bandwidth is not possible. Remote command: <code>INSTRument:COUPle:BANDwidth</code> on page 638
"Video Bandwidth"	Synchronizes the video bandwidth. <b>Note:</b> Simultaneous synchronization of the video bandwidth and the resolution bandwidth is not possible. Remote command: <code>INSTRument:COUPle:VBW</code> on page 641
"Limit Lines"	Activates the limit line over all channels. <b>Note:</b> Limit lines are only synchronized over channels if the limit line is compatible to the channel configuration (especially units of the x- and y-axis). Remote command: <code>INSTRument:COUPle:LIMit</code> on page 639
"AC DC Coupling"	Synchronizes the <b>input coupling</b> . Remote command: <code>INSTRument:COUPle:ACDC</code> on page 637
"Output Configuration"	Synchronizes the <b>settings for signal output</b> . <b>Note:</b> Changing the state of the output coupling here adjusts the state of the <b>Output Coupling</b> button in the "Output" dialog box. Remote command:
"Preselector"	Synchronizes the <b>preselector configuration</b> (state, mode and filter characteristics). Remote command: <code>INSTRument:COUPle:PRESel</code> on page 640



Note that you cannot synchronize all parameters at the same time, because some parameters are interdependent. For example, you cannot synchronize the resolution and video bandwidth simultaneously, because the video bandwidth depends on the resolution bandwidth and vice versa.

### Selecting all or no coupling mechanisms

Select all items available in the general coupling manager using the "Enable All Items" button.

Note that you cannot actually select all items, because some of them are mutually exclusive.

Deselect all items available in the coupling manager using the "Disable All Items" button.

Remote command:  
not supported

### Restoring the default configuration

You can restore the default parameter coupling configuration any time with the "Default Config" button.

Remote command:  
not supported

## 11.7.2 Using the Custom Coupling Manager

**Access:** [SETUP] > "Parameter Coupling" > "User Coupling"

The "User Coupling" tab of the coupling manager contains several features that allow you to create new and highly customized synchronization mechanisms.

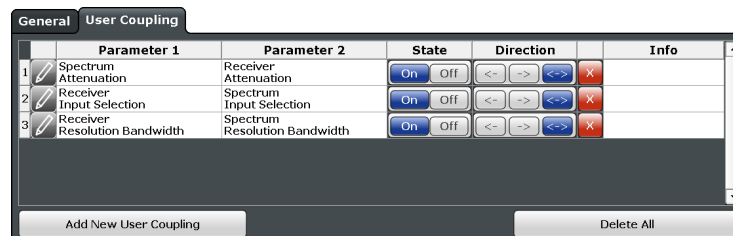

The dialog contains a table that shows the custom couplings that you have already created (if you have not yet created a custom coupling, the table is empty). In addition, it provides access to another dialog box that allows you to define a custom coupling.

<Number>                      Index number of the corresponding coupling mechanism.  
Remote command: `INSTrument:COUPle:USER<j>:NUMBers:LIST?`  
on page 646



Opens a dialog box to edit the selected coupling.  
Remote command: `INSTrument:COUPle:USER<j>` on page 642

Parameter 1 / 2                      Shows the parameters that are coupled.  
Remote command: `INSTrument:COUPle:USER<j>:NEW?` on page 644

Synchronizing Measurement Channel Configuration

State	Turns the coupling on and off. Remote command: <code>INSTRument:COUPle:USER&lt;j&gt;:STATe</code> on page 648
Direction	Selects the direction(s) in which the coupling is applied. Remote command: <code>INSTRument:COUPle:USER&lt;j&gt;:RELation</code> on page 647
	Deletes the selected coupling. Remote command: <code>INSTRument:COUPle:USER&lt;j&gt;:REMOve</code> on page 647
Info	Shows information (for example restrictions) for the selected coupling. Note that in most cases, no information is displayed. Remote command: <code>INSTRument:COUPle:USER&lt;j&gt;:INFO?</code> on page 644

**Creating and editing synchronization mechanisms**

**Access:** [SETUP] > "Parameter Coupling" > "User Coupling" > "Add New User Coupling"

User couplings are a way to utilize coupling mechanisms other than those available in the "General" tab of the coupling manager. Using those allows you to create highly customized couplings between measurement channels.

Compared to the predefined couplings, user couplings do not necessarily have to synchronize all active measurement channels. Instead you can define specific channels that are synchronized with each other (in any combination you wish for), while other channels remain independent.

**Example:**

You currently run two instances of the spectrum application, two instances of the receiver application and one instance of the analog demodulator.

In this scenario, you could, for example, synchronize only the first instance of the spectrum application with the first instance of the receiver application, while the other three channels remain independent.

Alternatively, you could, for example, synchronize all instances of the receiver application, while the spectrum and analog demodulation applications remain independent.

[Selecting the channels to synchronize](#)..... 339

[Selecting the measurement windows to synchronize](#)..... 340

[Selecting the parameter to synchronize](#)..... 340

[Applying the coupling mechanism](#)..... 341

**Selecting the channels to synchronize**

You can select the channels you would like to synchronize from the "Channel 1" and "Channel 2" dropdown menu.

The contents of the dropdown menu depends on the number and type of measurement channels that are currently active. In addition, the availability of the "Channel 2" dropdown menu depends on the item you have selected from the "Channel 1" dropdown menu.

- **<channel name>**  
Synchronizes **two specific channels** of the same type or of different type.

The <channel name> of the currently active channels is displayed in the channel bar. Because channel names are arbitrary, the labels of the items in the dropdown menu are variable.

When you select a specific channel, the "Channel 2" dropdown menu is available to select the second channel.

**Note:** If you want to synchronize another channel, you have to define an additional user coupling.

- **All <application type>**

Synchronizes all active **channels of the same application** (receiver, spectrum, I/Q analyzer or analog demodulation).

In that case, the "Channel 2" dropdown menu is not available.

- **All channels**

Synchronizes **all active channels**, regardless of their type and name.

This is basically the same as the coupling available in the "General" tab of the coupling manager.

The "Channel 2" dropdown menu is not available for synchronization across all channels.

Remote command:

Query channel: `INSTrument:COUPlE:USER<j>:CHANnel:LIST?` on page 642

Select channel: `INSTrument:COUPlE:USER<j>:NEW?` on page 644

Select channel: `INSTrument:COUPlE:USER<j>` on page 642

### Selecting the measurement windows to synchronize

Available for synchronization of instances of the analog demodulation application.

When you are synchronizing an instance of the analog demodulation application, you can also select the measurement window that should be synchronized. This feature is available, because, in the analog demodulation application, the measurement windows can have configurations that are independent from each other.

You can select the windows you would like to synchronize from the "Specifics for Window" dropdown menus.

Remote command:

Query windows: `INSTrument:COUPlE:USER<j>:WINDow:LIST?` on page 648

Select a window with `INSTrument:COUPlE:USER<j>:NEW?` on page 644

Select a window with `INSTrument:COUPlE:USER<j>` on page 642

### Selecting the parameter to synchronize

You can synchronize various parameters and settings from different categories across measurement channels.

To synchronize a parameter, select one from the "Coupling Elements" list. The list contains only parameters that are available in the application you have selected from the "Channel <x>" dropdown menu. So, for example, synchronizing the reference level is not possible if one of the channels you would like to synchronize is an instance of the receiver application.

Note that the "Coupling Elements 2" list is available only when you have selected synchronization across two specific channels (and not all channels of the same kind or all channels). In addition, the second list shows only parameters that are compatible to the first channel. If there is no compatible parameter, the list remains empty.

**Tip:** The "Category" dropdown menu filters the available parameters by a certain category.

Remote command:

Query parameters: `INSTrument:COUPle:USER<j>:ELEMeNt:LIST?` on page 643

Select parameter: `INSTrument:COUPle:USER<j>:NEW?` on page 644

Select parameter: `INSTrument:COUPle:USER<j>` on page 642

### Applying the coupling mechanism

When you are done configuring a new synchronization mechanism, save your settings with the "Couple Selected Parameters" button.

The new coupling mechanism is now displayed in the custom coupling table and you can apply it whenever you like.

Remote command:

`INSTrument:COUPle:USER<j>:NEW?` on page 644

`INSTrument:COUPle:USER<j>` on page 642

(Both commands also couple the parameters.)

## 11.7.3 Example for a User-Defined Parameter Coupling

Currently two Spectrum application channels are active, one VSA channel, and two Analog Demodulation channels.

### Synchronizing all Spectrum channels

The following example demonstrates how to synchronize the center frequency in all Spectrum application channels, while the VSA and Analog Demodulation applications remain independent.

1. Select the [SETUP] key.
2. Select "Parameter Coupling".
3. Select the "User Coupling" tab.
4. Select "Add New User Coupling".
5. From the "Channel 1" list, select "All Spectrum".
6. From the "Coupling Element 1" list, select "Center Frequency".
7. Select "Couple Selected Parameters".
8. Close the "Parameter Coupling" dialog box.
9. In the first Spectrum channel, change the "Center Frequency" to 1 GHz.
10. Switch to the second Spectrum channel.

The center frequency in the second Spectrum channel is also set to 1 GHz.

### Synchronizing specific channels

The following example demonstrates how to synchronize the attenuation only for the first Spectrum channel and the first Analog Demodulation channel, while the other three channels remain independent.

1. Select "Add New User Coupling".
2. From the "Channel 1" list, select "Spectrum 1".
3. From the "Coupling Element 1" list, select "Attenuation".
4. From the "Channel 2" list, select "AnaDemod 1".
5. From the "Coupling Element 2" list, select "Attenuation".
6. Select "Couple Selected Parameters".
7. Close the "Parameter Coupling" dialog box.
8. In the first Spectrum channel, change the "Attenuation" to 15 dB.
9. Switch to the first Analog Demodulation channel.

The attenuation in the second Analog Demodulation channel is also set to 15 dB.

### Synchronizing markers in Analog Demodulation windows

Now you have two Analog Demodulation channels. AnaDemod1 has an FM Spectrum and an FM Time Domain window. AnaDemod2 has an RF Spectrum and an RF Time Domain window. Only when the frequency marker in the FM Spectrum window is moved, the marker in the RF Spectrum window is to move to the same position.

1. Select "Add New User Coupling".
2. From the "Channel 1" list, select "AnaDemod 1".
3. From the "Coupling Element 1" list, select "Frequency Marker 1".
4. From the "Specifics for Window" list, select window "1" (which is the FM Spectrum window).
5. From the "Channel 2" list, select "AnaDemod 2".
6. From the "Coupling Element 2" list, select "Frequency Marker 1".
7. From the "Specifics for Window" list, select window "1" (which is the RF Spectrum window).
8. Select "Couple Selected Parameters".
9. In the "Parameter Coupling" dialog box, for the coupling definition for the frequency markers in the Analog Demodulation channels, select the "Direction": "->".
10. Close the "Parameter Coupling" dialog box.
11. In the first AnaDemod channel, set the frequency marker in the FM Spectrum to 900 MHz.

In the second AnaDemod channel, the frequency marker in the RF Spectrum is also at 900 MHz.

12. In the second AnaDemod channel, set the frequency marker in the RF Spectrum to 1100 MHz.

In the first AnaDemod channel, the frequency marker in the FM Spectrum is still at 900 MHz.

## 12 Network and Remote Operation

In addition to working with the R&S ESW interactively, located directly at the instrument, it is also possible to operate and control it from a remote PC. Various methods for remote control are supported:

- Connecting the instrument to a (LAN) network
- Using the LXI browser interface in a LAN network
- Using the Windows Remote Desktop application in a LAN network
- Connecting a PC via the GPIB interface

How to configure the remote control interfaces is described in [Chapter 12.5, "How to Set Up a Network and Remote Control"](#), on page 397.

• <a href="#">Remote Control Basics</a> .....	344
• <a href="#">GPIB Languages</a> .....	383
• <a href="#">The IECWIN Tool</a> .....	385
• <a href="#">Network and Remote Control Settings</a> .....	386
• <a href="#">How to Set Up a Network and Remote Control</a> .....	397

### 12.1 Remote Control Basics

Basic information on operating an instrument via remote control is provided here. This information applies to all applications and operating modes on the R&S ESW.



For additional information on remote control of spectrum analyzers see the following application notes available from the Rohde & Schwarz website:

[1EF62: Hints and Tricks for Remote Control of Spectrum and Network Analyzers](#)

[1MA171: How to use Rohde & Schwarz Instruments in MATLAB](#)

[1MA208: Fast Remote Instrument Control with HiSLIP](#)

• <a href="#">Remote Control Interfaces and Protocols</a> .....	344
• <a href="#">SCPI (Standard Commands for Programmable Instruments)</a> .....	353
• <a href="#">VISA Libraries</a> .....	353
• <a href="#">Messages</a> .....	354
• <a href="#">SCPI Command Structure</a> .....	355
• <a href="#">Command Sequence and Synchronization</a> .....	363
• <a href="#">Status Reporting System</a> .....	365
• <a href="#">General Programming Recommendations</a> .....	382

#### 12.1.1 Remote Control Interfaces and Protocols

The <instrument> supports different interfaces and protocols for remote control. The following table gives an overview.

Table 12-1: Remote control interfaces and protocols

Interface	Protocols, VISA <sup>*)</sup> address string	Remarks
Local Area Network (LAN)	<ul style="list-style-type: none"> <li>• <b>HISLIP</b> High-Speed LAN Instrument Protocol (IVI-6.1) TCPIP::host address::hislip0[::INSTR]</li> <li>• <b>VXI-11</b> TCPIP::host address::inst0[::INSTR] Library: VISA</li> <li>• <b>socket communication</b> (Raw Ethernet, simple Telnet) TCPIP::host address[::LAN device name]::&lt;port&gt;:: SOCKET Library: VISA or socket controller</li> </ul>	<p>A LAN connector is located on the rear panel of the instrument.</p> <p>The interface is based on TCP/IP and supports various protocols.</p> <p>For a description of the protocols refer to:</p> <p><a href="#">VXI-11 Protocol</a></p> <p><a href="#">HiSLIP Protocol</a></p> <p><a href="#">Socket Communication</a></p>
GPIB (IEC/IEEE Bus Interface)	VISA <sup>*)</sup> address string: GPIB::primary address[::INSTR] (no secondary address)	<p>A GPIB bus interface according to the IEC 625.1/IEEE 488.1 standard is located on the rear panel of the instrument.</p> <p>For a description of the interface refer to <a href="#">12.1.1.2 GPIB Interface (IEC 625/IEEE 418 Bus Interface)</a>.</p>
USB	VISA <sup>*)</sup> address string: USB::<vendor ID>::<product_ID>::<serial_number>[::INSTR]	<p>USB connectors are located on the front and rear panel of the instrument.</p> <p>For a description of the interface refer to <a href="#">12.1.1.3 USB Interface</a>.</p>
<p><sup>*)</sup> VISA is a standardized software interface library providing input and output functions to communicate with instruments. A VISA installation on the controller is a prerequisite for remote control using the indicated interfaces.            (See also <a href="#">Chapter 12.1.3, "VISA Libraries"</a>, on page 353).</p>		



Within this interface description, the term GPIB is used as a synonym for the IEC/IEEE bus interface.

### 12.1.1.1 LAN Interface

To be integrated in a LAN, the instrument is equipped with a LAN interface, consisting of a connector, a network interface card and protocols. The network card can be operated with the following interfaces:

- 10 Mbit/s Ethernet IEEE 802.3
- 100 Mbit/s Ethernet IEEE 802.3u
- 1Gbit/s Ethernet IEEE 802.3ab

For remote control via a network, the PC and the instrument must be connected via the LAN interface to a common network with TCP/IP network protocol. They are connected using a commercial RJ45 cable (shielded or unshielded twisted pair category 5). The TCP/IP network protocol and the associated network services are preconfigured on the instrument. Software for instrument control and the VISA program library must be installed on the controller.



### VISA library

Instrument access is usually achieved from high level programming platforms using VISA as an intermediate abstraction layer. VISA encapsulates the low level VXI, GPIB, LAN or USB function calls and thus makes the transport interface transparent for the user. See [Chapter 12.1.3, "VISA Libraries"](#), on page 353 for details.

The R&S ESW supports various LAN protocols such as LXI, RSIB, raw socket or the newer HiSLIP protocol.

### IP address

Only the IP address or a valid DNS host name is required to set up the connection. The host address is part of the "VISA resource string" used by the programs to identify and control the instrument.

The VISA resource string has the form:

```
TCPIP::host address[::LAN device name][::INSTR]
```

or

```
TCPIP::host address::port::SOCKET
```

where:

- **TCPIP** designates the network protocol used
- **host address** is the IP address or host name of the device
- **LAN device name** defines the protocol and the instance number of a sub-instrument;
  - `inst0` selects the VXI-11 protocol (default)
  - `hislip0` selects the newer HiSLIP protocol
- **INSTR** indicates the instrument resource class (optional)
- **port** determines the used port number
- **SOCKET** indicates the raw network socket resource class

### Example:

- Instrument has the IP address *192.1.2.3*; the valid resource string using VXI-11 protocol is:  

```
TCPIP::192.1.2.3::INSTR
```
- The DNS host name is *ESW-123456*; the valid resource string using HiSLIP is:  

```
TCPIP::ESW-123456::hislip0
```
- A raw socket connection can be established using:  

```
TCPIP::192.1.2.3::5025::SOCKET
```



### Identifying instruments in a network

If several instruments are connected to the network, each instrument has its own IP address and associated resource string. The controller identifies these instruments by means of the resource string.

For details on configuring the LAN connection, see [Chapter 12.5.1, "How to Configure a Network"](#), on page 397.

• <a href="#">VXI-11 Protocol</a> .....	347
• <a href="#">HiSLIP Protocol</a> .....	347
• <a href="#">Socket Communication</a> .....	347
• <a href="#">LXI Web Browser Interface</a> .....	348

### VXI-11 Protocol

The VXI-11 standard is based on the ONC RPC (Open Network Computing Remote Procedure Call) protocol which in turn relies on TCP/IP as the network/transport layer. The TCP/IP network protocol and the associated network services are preconfigured. TCP/IP ensures connection-oriented communication, where the order of the exchanged messages is adhered to and interrupted links are identified. With this protocol, messages cannot be lost.

### HiSLIP Protocol

The HiSLIP (**H**igh **S**peed **L**AN **I**nstrument **P**rotocol) is the successor protocol for VXI-11 for TCP-based instruments specified by the IVI foundation. The protocol uses two TCP sockets for a single connection - one for fast data transfer, the other for non-sequential control commands (e.g. `Device Clear` or `SRQ`).

HiSLIP has the following characteristics:

- High performance as with raw socket network connections
- Compatible IEEE 488.2 support for Message Exchange Protocol, Device Clear, Serial Poll, Remote/Local, Trigger, and Service Request
- Uses a single IANA registered port (4880), which simplifies the configuration of fire-walls
- Supports simultaneous access of multiple users by providing versatile locking mechanisms
- Usable for IPv6 or IPv4 networks



Using VXI-11, each operation is blocked until a VXI-11 device handshake returns. However, using HiSLIP, data is sent to the device using the "fire and forget" method with immediate return. Thus, a successful return of a VISA operation such as `viWrite()` does not guarantee that the instrument has finished or started the requested command, but is delivered to the TCP/IP buffers.

For more information see also the application note:

[1MA208: Fast Remote Instrument Control with HiSLIP](#)

### Socket Communication

An alternative way for remote control of the software is to establish a simple network communication using sockets. The socket communication, also referred to as "Raw Ethernet communication", does not necessarily require a VISA installation on the remote controller side. It is available by default on all operating systems.

The simplest way to establish socket communication is to use the built-in telnet program. The telnet program is part of every operating system and supports a communication with the software on a command-by-command basis. For more convenience and to enable automation by means of programs, user-defined sockets can be programmed.

Socket connections are established on a specially defined port. The socket address is a combination of the IP address or the host name of the instrument and the number of the port configured for remote-control. All R&S ESW use port number 5025 for this purpose. The port is configured for communication on a command-to-command basis and for remote control from a program.

### LXI Web Browser Interface

LAN eXtensions for Instrumentation (LXI) is an instrumentation platform for measuring instruments and test systems that is based on standard Ethernet technology. LXI is intended to be the LAN-based successor to GPIB, combining the advantages of Ethernet with the simplicity and familiarity of GPIB. The LXI browser interface allows for easy configuration of the LAN and remote control of the R&S ESW without additional installation requirements.

The instrument's LXI web browser interface works correctly with all W3C compliant browsers.

Via the LXI browser interface to the R&S ESW you can control the instrument remotely from another PC. Manual instrument controls are available via the front panel simulation. File upload and download between the instrument and the remote PC is also available. Using this feature, several users can access *and operate* the R&S ESW simultaneously. This is useful for troubleshooting or training purposes.

For details, see [Chapter 12.5.1.4, "How to Configure the LAN Using the LXI Web Browser Interface"](#), on page 401 and [Chapter 12.5.5, "How to Control the R&S ESW via the Web Browser Interface"](#), on page 406.



If you do not want other users in the LAN to be able to access and operate the R&S ESW you can deactivate this function.

See [Chapter 12.5.6, "How to Deactivate the Web Browser Interface"](#), on page 407.

---



### Restrictions

Only user accounts with administrator rights can use the LXI functionality.

For details, see [Chapter 2.2.3, "Login"](#), on page 26.

---

### To display the LXI web browser interface

- ▶ In the address field of the browser on your PC, type the host name or IP address of the instrument, for example: `http://10.113.10.203`.

The instrument home page (welcome page) opens.

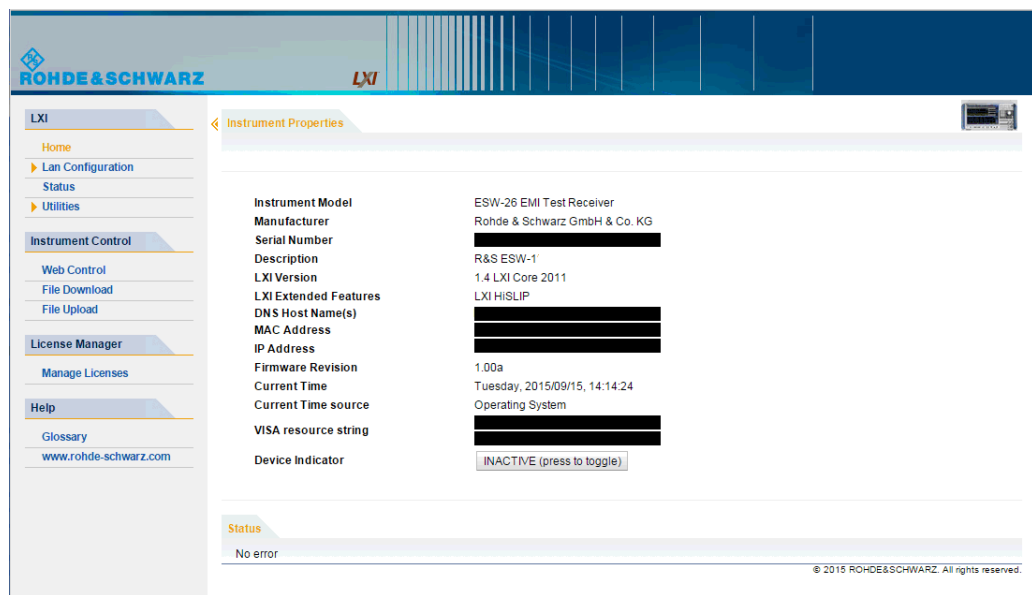

The navigation pane of the browser interface contains the following elements:

- "LXI"
  - "Home" opens the instrument home page.  
The home page displays the device information required by the LXI standard, including the VISA resource string in read-only format.  
The "Device Indicator" button allows you to physically identify the instrument. This is useful if you have several instruments and want to know which instrument the LXI home page belongs to. To identify the instrument, activate the "Device Indicator" . Then check the "LAN Status" indicator of the instruments.
  - "LAN Configuration" allows you to configure LAN parameters and to initiate a ping.  
(See ["Ping Client"](#) on page 403.)  
(See
  - "Status Bar" displays information about the LXI status of the instrument.
  - "Utilities" provides access to the LXI event log functionality required by the LXI standard.
- "Instrument Control"
  - "Web Control" provides remote access to the instrument via VNC (no installation required). Manual instrument controls are available via the front panel simulation.
  - "File Download" downloads files from the instrument.
  - "File Upload" uploads files to the instrument.  
(See [Chapter 12.5.5, "How to Control the R&S ESW via the Web Browser Interface"](#), on page 406.)
- "License Manager"
  - "License Manager" allows you to install or uninstall license keys and to activate, register or unregister licenses.
- "Help"

- "Glossary" explains terms related to the LXI standard.
- "www.rohde-schwarz.com" opens the Rohde & Schwarz home page.

### 12.1.1.2 GPIB Interface (IEC 625/IEEE 418 Bus Interface)

A GPIB interface is integrated on the rear panel of the instrument.

By connecting a PC to the R&S ESW via the GPIB connection you can send remote commands to control and operate the instrument.

To be able to control the instrument via the GPIB bus, the instrument and the controller must be linked by a GPIB bus cable. A GPIB bus card, the card drivers and the program libraries for the programming language used must be provided in the controller. The controller must address the instrument with the GPIB bus address (see [Chapter 12.5.1.5, "How to Change the GPIB Instrument Address"](#), on page 403). You can set the GPIB address and the ID response string. The GPIB language is set as SCPI by default and cannot be changed for the R&S ESW.

#### Notes and Conditions

In connection with the GPIB interface, note the following:

- Up to 15 instruments can be connected
- The total cable length is restricted to a maximum of 15 m or 2 m times the number of devices, whichever is less; the cable length between two instruments should not exceed 2 m.
- A wired "OR"-connection is used if several instruments are connected in parallel.
- Any connected IEC-bus cables should be terminated by an instrument or controller.

#### GPIB Interface Messages

Interface messages are transmitted to the instrument on the data lines, with the attention line (ATN) being active (LOW). They are used for communication between the controller and the instrument and can only be sent by a computer which has the function of a GPIB bus controller. GPIB interface messages can be further subdivided into:

- **Universal commands:** act on all instruments connected to the GPIB bus without previous addressing
- **Addressed commands:** only act on instruments previously addressed as listeners

The following figure provides an overview of the available communication lines used by the GPIB interface.

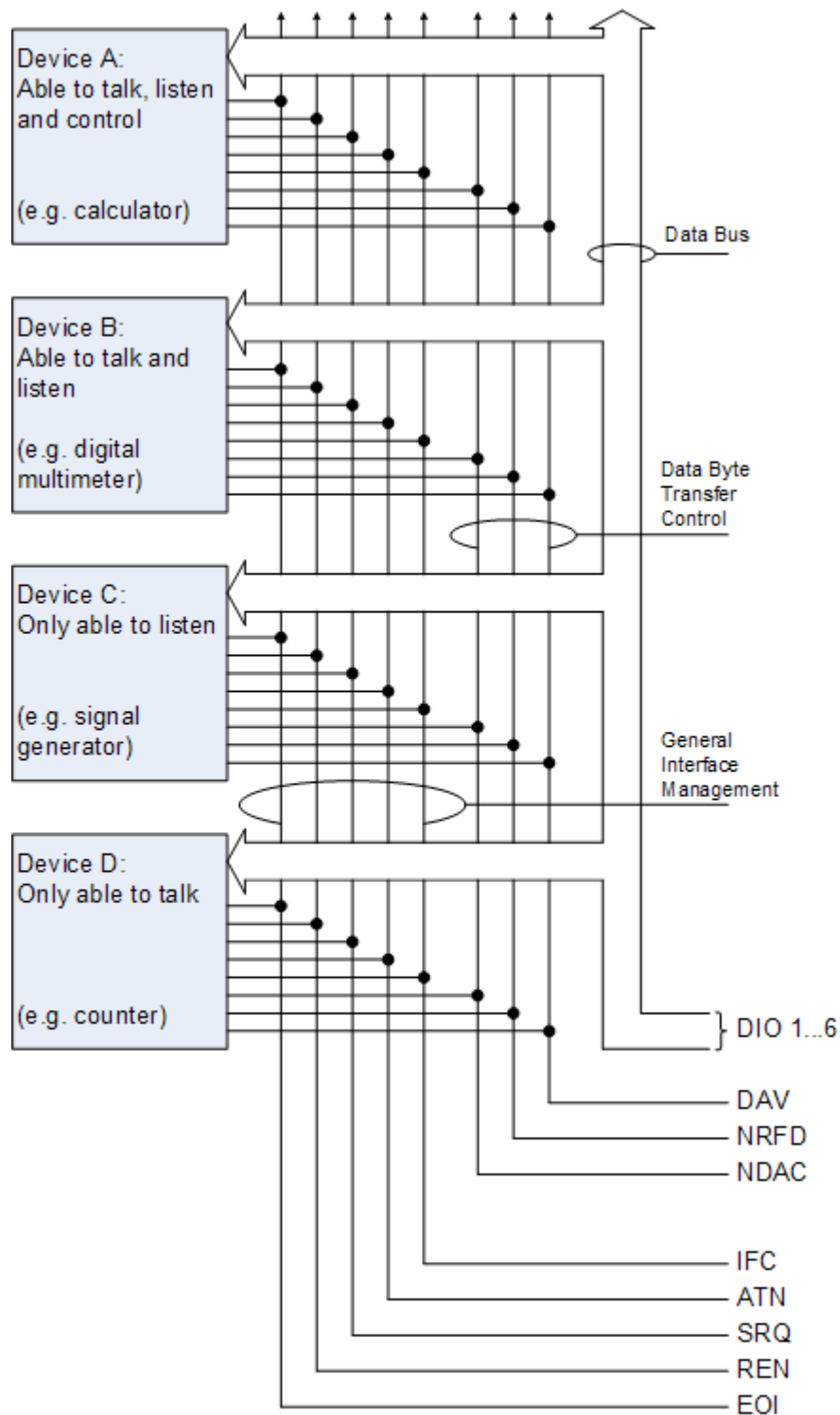

Figure 12-1: Communication lines used by the GPIB interface

### Universal Commands

Universal commands are encoded in the range 10 through 1F hex. They affect all instruments connected to the bus and do not require addressing.

Command	Effect on the instrument
DCL (Device Clear)	Aborts the processing of the commands just received and sets the command processing software to a defined initial state. Does not change the instrument settings.
IFC (Interface Clear) *)	Resets the interfaces to the default setting.
LLO (Local Lockout)	The "Local" softkey is disabled. Manual operation is no longer available until <i>GTL</i> is executed.
SPE (Serial Poll Enable)	Ready for serial poll.
SPD (Serial Poll Disable)	End of serial poll.
PPU (Parallel Poll Unconfigure)	End of the parallel-poll state.
*) IFC is not a real universal command, it is sent via a separate line; however, it also affects all instruments connected to the bus and does not require addressing	

### Addressed Commands

Addressed commands are encoded in the range 00 through 0F hex. They only affect instruments addressed as listeners.

Command	Effect on the instrument
GET (Group Execute Trigger)	Triggers a previously active instrument function (e.g. a sweep). The effect of the command is the same as with that of a pulse at the external trigger signal input.
GTL (Go to Local)	Transition to the "local" state (manual control).
GTR (Go to Remote)	Transition to the "remote" state (remote control).
PPC (Parallel Poll Configure)	Configures the instrument for parallel poll.
SDC (Selected Device Clear)	Aborts the processing of the commands just received and sets the command processing software to a defined initial state. Does not change the instrument setting.

#### 12.1.1.3 USB Interface

For remote control via the USB connection, the PC and the instrument must be connected via the USB type B interface. A USB connection requires the VISA library to be installed. VISA detects and configures the R&S instrument automatically when the USB connection is established. You do not have to enter an address string or install a separate driver.

#### USB address

The used USB address string is:

```
USB::::<product ID>::[::INSTR]
```

where:

- <vendor ID> is the vendor ID for Rohde & Schwarz (0x0AAD)
- <product ID> is the product ID for the Rohde & Schwarz instrument
- <serial number> is the individual serial number on the rear of the instrument

**Table 12-2: Product IDs for R&S ESW**

Instrument model	Product ID
ESW8	16E
ESW26	16F
ESW44	170

**Example:**

```
USB::0x0AAD::0x0016E::100001::INSTR
```

0x0AAD is the vendor ID for Rohde&Schwarz

0x0016E is the product ID for the R&S ESW44

100001 is the serial number of the particular instrument

## 12.1.2 SCPI (Standard Commands for Programmable Instruments)

SCPI commands - messages - are used for remote control. Commands that are not taken from the SCPI standard follow the SCPI syntax rules. The R&S ESW supports the SCPI version 1999. The SCPI standard is based on standard IEEE 488.2 and aims at the standardization of device-specific commands, error handling and the status registers. The tutorial "Automatic Measurement Control - A tutorial on SCPI and IEEE 488.2" from John M. Pieper (R&S order number 0002.3536.00) offers detailed information on concepts and definitions of SCPI.

Tables provide a fast overview of the bit assignment in the status registers. The tables are supplemented by a comprehensive description of the status registers.

## 12.1.3 VISA Libraries

VISA is a standardized software interface library providing input and output functions to communicate with instruments. The I/O channel (LAN or TCP/IP, USB, ...) is selected at initialization time by one of the following:

- The channel-specific address string ("VISA resource string") indicated in [Table 12-1](#)
- An appropriately defined VISA alias (short name).

A VISA installation is a prerequisite for remote control using the following interfaces:

- [Chapter 12.1.1.2, "GPIB Interface \(IEC 625/IEEE 418 Bus Interface\)"](#), on page 350
- [Chapter 12.1.1.1, "LAN Interface"](#), on page 345
- [Chapter 12.1.1.3, "USB Interface"](#), on page 352



For more information about VISA, refer to the user documentation.

### 12.1.4 Messages

The messages transferred on the data lines are divided into the following categories:

- **Interface messages**  
Interface messages are transmitted to the instrument on the data lines, with the attention line being active (LOW). They are used to communicate between the controller and the instrument. Interface messages can only be sent by instruments that have GPIB bus functionality. For details see the sections for the required interface.
- **Instrument messages**  
Instrument messages are employed in the same way for all interfaces, if not indicated otherwise in the description. Structure and syntax of the instrument messages are described in [Chapter 12.1.5, "SCPI Command Structure"](#), on page 355. A detailed description of all messages available for the instrument is provided in the chapter "Remote Control Commands".  
There are different types of instrument messages, depending on the direction they are sent:
  - Commands
  - Instrument responses

#### Commands

Commands (program messages) are messages the controller sends to the instrument. They operate the instrument functions and request information. The commands are subdivided according to two criteria:

- According to the effect they have on the instrument:
  - **Setting commands** cause instrument settings such as a reset of the instrument or setting the frequency.
  - **Queries** cause data to be provided for remote control, e.g. for identification of the instrument or polling a parameter value. Queries are formed by directly appending a question mark to the command header.
- According to their definition in standards:
  - **Common commands**: their function and syntax are precisely defined in standard IEEE 488.2. They are employed identically on all instruments (if implemented). They refer to functions such as management of the standardized status registers, reset and self-test.
  - **Instrument control commands** refer to functions depending on the features of the instrument such as frequency settings. Many of these commands have also been standardized by the SCPI committee. These commands are marked as "SCPI confirmed" in the command reference chapters. Commands without this SCPI label are device-specific; however, their syntax follows SCPI rules as permitted by the standard.

### Instrument responses

Instrument responses (response messages and service requests) are messages the instrument sends to the controller after a query. They can contain measurement results, instrument settings and information on the instrument status.

## 12.1.5 SCPI Command Structure

SCPI commands consist of a header and, in most cases, one or more parameters. The header and the parameters are separated by a "white space" (ASCII code 0 to 9, 11 to 32 decimal, e.g. blank). The headers may consist of several mnemonics (keywords). Queries are formed by appending a question mark directly to the header.

The commands can be either device-specific or device-independent (common commands). Common and device-specific commands differ in their syntax.

### 12.1.5.1 Syntax for Common Commands

Common (= device-independent) commands consist of a header preceded by an asterisk (\*), and possibly one or more parameters.

**Table 12-3: Examples of common commands**

*RST	RESET	Resets the instrument.
*ESE	EVENT STATUS ENABLE	Sets the bits of the event status enable registers.
*ESR?	EVENT STATUS QUERY	Queries the contents of the event status register.
*IDN?	IDENTIFICATION QUERY	Queries the instrument identification string.

### 12.1.5.2 Syntax for Device-Specific Commands



Not all commands used in the following examples are necessarily implemented in the instrument. For demonstration purposes only, assume the existence of the following commands for this section:

- DISPLAY[:WINDow<1...4>]:MAXimize <Boolean>
- FORMat:READings:DATA <type>[,<length>]
- HCOpy:DEvIce:COLor <Boolean>
- HCOpy:DEvIce:CMAP:COLor:RGB <red>,<green>,<blue>
- HCOpy[:IMMediate]
- HCOpy:ITEM:ALL
- HCOpy:ITEM:LABel <string>
- HCOpy:PAGE:DIMensions:QUADrant [<N>]
- HCOpy:PAGE:ORientation LANDscape | PORTrait
- HCOpy:PAGE:SCALE <numeric value>
- MMEMoRY:COpy <file\_source>,<file\_destination>
- SENSE:BANDwidth|BWIDth[:RESolution] <numeric\_value>
- SENSE:FREQuency:STOP <numeric value>
- SENSE:LIST:FREQuency <numeric\_value>{,<numeric\_value>}

- [Long and short form](#)..... 356
- [Numeric Suffixes](#)..... 356
- [Optional Mnemonics](#)..... 357

#### Long and short form

The mnemonics feature a long form and a short form. The short form is marked by upper case letters, the long form corresponds to the complete word. Either the short form or the long form can be entered; other abbreviations are not permitted.

#### Example:

HCOpy:DEvIce:COLor ON is equivalent to HCOP:DEV:COL ON.



#### Case-insensitivity

Upper case and lower case notation only serves to distinguish the two forms in the manual, the instrument itself is case-insensitive.

#### Numeric Suffixes

If a command can be applied to multiple instances of an object, e.g. specific channels or sources, the required instances can be specified by a suffix added to the command. Numeric suffixes are indicated by angular brackets (<1...4>, <n>, <i>) and are replaced by a single value in the command. Entries without a suffix are interpreted as having the suffix 1.

**Example:**

Definition: `HCOPY:PAGE:DIMensions:QUADrant [<N>]`

Command: `HCOP:PAGE:DIM:QUAD2`

This command refers to the quadrant 2.

**Different numbering in remote control**

For remote control, the suffix may differ from the number of the corresponding selection used in manual operation. SCPI prescribes that suffix counting starts with 1. Suffix 1 is the default state and used when no specific suffix is specified.

Some standards define a fixed numbering, starting with 0. If the numbering differs in manual operation and remote control, it is indicated for the corresponding command.

**Optional Mnemonics**

Some command systems permit certain mnemonics to be inserted into the header or omitted. These mnemonics are marked by square brackets in the description. The instrument must recognize the long command to comply with the SCPI standard. Some commands are considerably shortened by these optional mnemonics.

**Example:**

Definition: `HCOPY[:IMMEDIATE]`

Command: `HCOP:IMM` is equivalent to `HCOP`

**Optional mnemonics with numeric suffixes**

Do not omit an optional mnemonic if it includes a numeric suffix that is relevant for the effect of the command.

**Example:**

Definition: `DISPlay[:WINDow<1...4>]:MAXimize <Boolean>`

Command: `DISP:MAX ON` refers to window 1.

In order to refer to a window other than 1, you must include the optional `WINDow` parameter with the suffix for the required window.

`DISP:WIND2:MAX ON` refers to window 2.

**12.1.5.3 SCPI Parameters**

Many commands are supplemented by a parameter or a list of parameters. The parameters must be separated from the header by a "white space" (ASCII code 0 to 9, 11 to 32 decimal, e.g. blank).

The parameters required for each command and the allowed range of values are specified in the command description.

Allowed parameters are:

• <a href="#">Numeric Values</a> .....	358
• <a href="#">Special Numeric Values</a> .....	358
• <a href="#">Boolean Parameters</a> .....	359
• <a href="#">Text Parameters</a> .....	359
• <a href="#">Character Strings</a> .....	359
• <a href="#">Block Data</a> .....	360

### Numeric Values

Numeric values can be entered in any form, i.e. with sign, decimal point and exponent. Values exceeding the resolution of the instrument are rounded up or down. The mantissa may comprise up to 255 characters, the exponent must lie inside the value range -32000 to 32000. The exponent is introduced by an "E" or "e". Entry of the exponent alone is not allowed.

#### Example:

```
SENS:FREQ:STOP 1500000 = SENS:FREQ:STOP 1.5E6
```

### Units

For physical quantities, the unit can be entered. If the unit is missing, the basic unit is used. Allowed unit prefixes are:

- G (giga)
- MA (mega), MOHM, MHZ
- K (kilo)
- M (milli)
- U (micro)
- N (nano)

#### Example:

```
SENSe:FREQ:STOP 1.5GHz = SENSe:FREQ:STOP 1.5E9
```

Some settings allow relative values to be stated in percent. According to SCPI, this unit is represented by the `PCT` string.

#### Example:

```
HCOP:PAGE:SCAL 90PCT
```

### Special Numeric Values

The following mnemonics are special numeric values. In the response to a query, the numeric value is provided.

- **MIN and MAX:** denote the minimum and maximum value.
- **DEF:** denotes a preset value which has been stored in the EPROM. This value conforms to the default setting, as it is called by the `*RST` command.
- **UP and DOWN:** increases or reduces the numeric value by one step. The step width can be specified via an allocated step command for each parameter which can be set via `UP` and `DOWN`.

- **INF and NINF:** INFinity and negative INFinity (NINF) represent the numeric values 9.9E37 or -9.9E37, respectively. INF and NINF are only sent as instrument responses.
- **NAN:** Not A Number (NAN) represents the value 9.91E37. NAN is only sent as a instrument response. This value is not defined. Possible causes are the division of zero by zero, the subtraction of infinite from infinite and the representation of missing values.

**Example:**

Setting command: `SENSe:LIST:FREQ MAXimum`

Query: `SENS:LIST:FREQ?`

Response: `3.5E9`

**Queries for special numeric values**

The numeric values associated to `MAXimum`/`MINimum`/`DEFault` can be queried by adding the corresponding mnemonic after the quotation mark.

Example: `SENSe:LIST:FREQ? MAXimum`

Returns the maximum numeric value as a result.

**Boolean Parameters**

Boolean parameters represent two states. The "ON" state (logically true) is represented by "ON" or a numeric value 1. The "OFF" state (logically untrue) is represented by "OFF" or the numeric value 0. The numeric values are provided as the response for a query.

**Example:**

Setting command: `HCOPY:DEV:COL ON`

Query: `HCOPY:DEV:COL?`

Response: `1`

**Text Parameters**

Text parameters observe the syntactic rules for mnemonics, i.e. they can be entered using a short or long form. Like any parameter, they have to be separated from the header by a white space. In the response to a query, the short form of the text is provided.

**Example:**

Setting command: `HCOPY:PAGE:ORIENTATION LANDscape`

Query: `HCOP:PAGE:ORI?`

Response: `LAND`

**Character Strings**

Strings must always be entered in quotation marks (' or ").

**Example:**

```
HCOP:ITEM:LABel "Test1"
```

```
HCOP:ITEM:LABel 'Test1'
```

**Block Data**

Block data is a format which is suitable for the transmission of large amounts of data. For example, a command using a block data parameter has the following structure:

```
FORMat:READings:DATA #45168xxxxxxxx
```

The ASCII character # introduces the data block. The next number indicates how many of the following digits describe the length of the data block. In the example the 4 following digits indicate the length to be 5168 bytes. The data bytes follow. During the transmission of these data bytes all end or other control signs are ignored until all bytes are transmitted.

#0 specifies a data block of indefinite length. The use of the indefinite format requires a NL^END message to terminate the data block. This format is useful when the length of the transmission is not known or if speed or other considerations prevent segmentation of the data into blocks of definite length.

**12.1.5.4 Overview of Syntax Elements**

The following tables provide an overview of the syntax elements and special characters.

**Table 12-4: Syntax elements**

:	The colon separates the mnemonics of a command.
;	The semicolon separates two commands of a command line. It does not alter the path.
,	The comma separates several parameters of a command.
?	The question mark forms a query.
*	The asterisk marks a common command.
' '	Quotation marks introduce a string and terminate it (both single and double quotation marks are possible).
#	The hash symbol introduces binary, octal, hexadecimal and block data. <ul style="list-style-type: none"> <li>• Binary: #B10110</li> <li>• Octal: #O7612</li> <li>• Hexa: #HF3A7</li> <li>• Block: #21312</li> </ul>
	A "white space" (ASCII-Code 0 to 9, 11 to 32 decimal, e.g. blank) separates the header from the parameters.

Table 12-5: Special characters

	<p><b>Parameters</b></p> <p>A vertical stroke in parameter definitions indicates alternative possibilities in the sense of "or". The effect of the command differs, depending on which parameter is used.</p> <p>Example:</p> <p>Definition:HCOPY:PAGE:ORIENTATION LANDscape   PORTRait</p> <p>Command HCOP:PAGE:ORI LAND specifies landscape orientation</p> <p>Command HCOP:PAGE:ORI PORT specifies portrait orientation</p> <p><b>Mnemonics</b></p> <p>A selection of mnemonics with an identical effect exists for several commands. These mnemonics are indicated in the same line; they are separated by a vertical stroke. Only one of these mnemonics needs to be included in the header of the command. The effect of the command is independent of which of the mnemonics is used.</p> <p>Example:</p> <p>DefinitionSENSE:BANDwidth BWIDTH[:RESolution] &lt;numeric_value&gt;</p> <p>The two following commands with identical meaning can be created:</p> <p>SENS:BAND:RES 1</p> <p>SENS:BWID:RES 1</p>
[]	<p>Mnemonics in square brackets are optional and may be inserted into the header or omitted.</p> <p>Example: HCOpy[:IMMEDIATE]</p> <p>HCOP: IMM is equivalent to HCOP</p>
{ }	<p>Parameters in curly brackets are optional and can be inserted once or several times, or omitted.</p> <p>Example: SENSE:LIST:FREQuency &lt;numeric_value&gt;{,&lt;numeric_value&gt;}</p> <p>The following are valid commands:</p> <p>SENS:LIST:FREQ 10</p> <p>SENS:LIST:FREQ 10,20</p> <p>SENS:LIST:FREQ 10,20,30,40</p>

### 12.1.5.5 Structure of a Command Line

A command line may consist of one or several commands. It is terminated by one of the following:

- <New Line>
- <New Line> with EOI
- EOI together with the last data byte

Several commands in a command line must be separated by a semicolon ";".

**Example:**

```
MMEM:COPY "Test1","MeasurementXY";HCOP:ITEM ALL
```

This command line contains two commands. The first command belongs to the MMEM system, the second command belongs to the HCOP system. If the next command belongs to a different command system, the semicolon is followed by a colon.



**Example:**

```
HCOP:ITEM ALL;:HCOP:IMM
```

This command line contains two commands. Both commands are part of the HCOP command system, i.e. they have one level in common.

If the successive commands belong to the same system, having one or several levels in common, the command line can be abbreviated. When abbreviating the command line, the second command begins with the level below HCOP. The colon after the semi-colon is omitted. The abbreviated form of the command line reads as follows:

```
HCOP:ITEM ALL;IMM
```

**Example:**

```
HCOP:ITEM ALL
```

```
HCOP:IMM
```

A new command line always begins with the complete path.

**12.1.5.6 Responses to Queries**

A query is defined for each setting command unless explicitly specified otherwise. It is formed by adding a question mark to the associated setting command. According to SCPI, the responses to queries are partly subject to stricter rules than in standard IEEE 488.2.

- The requested parameter is transmitted without a header.  
**Example:** HCOP:PAGE:ORI?, **Response:** LAND
- Maximum values, minimum values and all other quantities that are requested via a special text parameter are returned as numeric values.  
**Example:** SENSE:FREQUENCY:STOP? MAX, **Response:** 3.5E9
- Numeric values are output without a unit. Physical quantities are referred to the basic units or to the units set using the Unit command. The response 3.5E9 in the previous example stands for 3.5 GHz.
- Truth values (Boolean values) are returned as 0 (for OFF) and 1 (for ON).  
**Example:**  
Setting command: HCOPI:DEV:COL ON  
Query: HCOPI:DEV:COL?  
Response: 1
- Text (character data) is returned in a short form.  
**Example:**  
Setting command: HCOPI:PAGE:ORIENTATION LANDscape  
Query: HCOPI:PAGE:ORI?  
Response: LAND
- Invalid numerical results  
In some cases, particularly when a result consists of multiple numeric values, invalid values are returned as 9.91E37 (not a number).

## 12.1.6 Command Sequence and Synchronization

IEEE 488.2 defines a distinction between overlapped and sequential commands:

- A sequential command is one which finishes executing before the next command starts executing. Commands that are processed quickly are usually implemented as sequential commands.
- An overlapping command is one which does not automatically finish executing before the next command starts executing. Usually, overlapping commands take longer to process and allow the program to do other tasks while being executed. If overlapping commands do have to be executed in a defined order, e.g. in order to avoid wrong measurement results, they must be serviced sequentially. This is called synchronization between the controller and the instrument.

Setting commands within one command line, even though they may be implemented as sequential commands, are not necessarily serviced in the order in which they have been received. In order to make sure that commands are actually carried out in a certain order, each command must be sent in a separate command line.

### Example: Commands and queries in one message

The response to a query combined in a program message with commands that affect the queried value is not predictable.

The following commands always return the specified result:

```
:FREQ:STAR 1GHZ;SPAN 100;:FREQ:STAR?
```

Result:

```
1000000000 (1 GHz)
```

Whereas the result for the following commands is not specified by SCPI:

```
:FREQ:STAR 1GHz;STAR?;SPAN 1000000
```

The result could be the value of `START` before the command was sent since the instrument might defer executing the individual commands until a program message terminator is received. The result could also be 1 GHz if the instrument executes commands as they are received.



As a general rule, send commands and queries in different program messages.

---

**Example: Overlapping command with \*OPC**

The instrument implements `INITiate[:IMMEDIATE]` as an overlapped command. Assuming that `INITiate[:IMMEDIATE]` takes longer to execute than `*OPC`, sending the following command sequence results in initiating a sweep and, after some time, setting the `OPC` bit in the `ESR`:

```
INIT; *OPC.
```

Sending the following commands still initiates a sweep:

```
INIT; *OPC; *CLS
```

However, since the operation is still pending when the instrument executes `*CLS`, forcing it into the "Operation Complete Command Idle" State (OCIS), `*OPC` is effectively skipped. The `OPC` bit is not set until the instrument executes another `*OPC` command.

**12.1.6.1 Preventing Overlapping Execution**

To prevent an overlapping execution of commands, one of the commands `*OPC`, `*OPC?` or `*WAI` can be used. All three commands cause a certain action only to be carried out after the hardware has been set. The controller can be forced to wait for the corresponding action to occur.

**Table 12-6: Synchronization using \*OPC, \*OPC? and \*WAI**

Command	Action	Programming the controller
*OPC	Sets the Operation Complete bit in the ESR after all previous commands have been executed.	<ul style="list-style-type: none"> <li>Setting bit 0 in the ESE</li> <li>Setting bit 5 in the SRE</li> <li>Waiting for service request (SRQ)</li> </ul>
*OPC?	Stops command processing until 1 is returned. This occurs when all pending operations are completed.	Send *OPC? directly after the command whose processing must be terminated before other commands can be executed.
*WAI	Stops further command processing until all commands sent before *WAI have been executed.	Send *WAI directly after the command whose processing must be terminated before other commands are executed.

Command synchronization using `*WAI` or `*OPC?` is a good choice if the overlapped command takes only little time to process. The two synchronization commands simply block overlapped execution of the command. Append the synchronization command to the overlapping command, for example:

```
SINGLE; *OPC?
```

For time consuming overlapped commands, you can allow the controller or the instrument to do other useful work while waiting for command execution. Use one of the following methods:

**\*OPC with a service request**

1. Set the OPC mask bit (bit no. 0) in the ESE: `*ESE 1`
2. Set bit no. 5 in the SRE: `*SRE 32` to enable ESB service request.
3. Send the overlapped command with `*OPC` .

4. Wait for a service request.

The service request indicates that the overlapped command has finished.

#### **\*OPC? with a service request**

1. Set bit no. 4 in the SRE: \*SRE 16 to enable MAV service request.
2. Send the overlapped command with \*OPC?.
3. Wait for a service request.

The service request indicates that the overlapped command has finished.

#### **Event status register (ESE)**

1. Set the OPC mask bit (bit no. 0) in the ESE: \*ESE 1
2. Send the overlapped command without \*OPC, \*OPC? or \*WAI.
3. Poll the operation complete state periodically (with a timer) using the sequence:  
\*OPC; \*ESR?

A return value (LSB) of 1 indicates that the overlapped command has finished.

## **12.1.7 Status Reporting System**

The status reporting system stores all information on the current operating state of the instrument, and on errors which have occurred. This information is stored in the status registers and in the error queue. Both can be queried via GPIB bus or LAN interface (STATus... commands).

(See [Chapter 13.10, "Using the Status Register"](#), on page 664).

- [Hierarchy of Status Registers](#)..... 365
- [Structure of a SCPI Status Register](#).....367
- [Contents of the Status Registers](#)..... 368
- [Application of the Status Reporting System](#).....379
- [Reset Values of the Status Reporting System](#)..... 381

### **12.1.7.1 Hierarchy of Status Registers**

As shown in the following figure, the status information is of hierarchical structure.

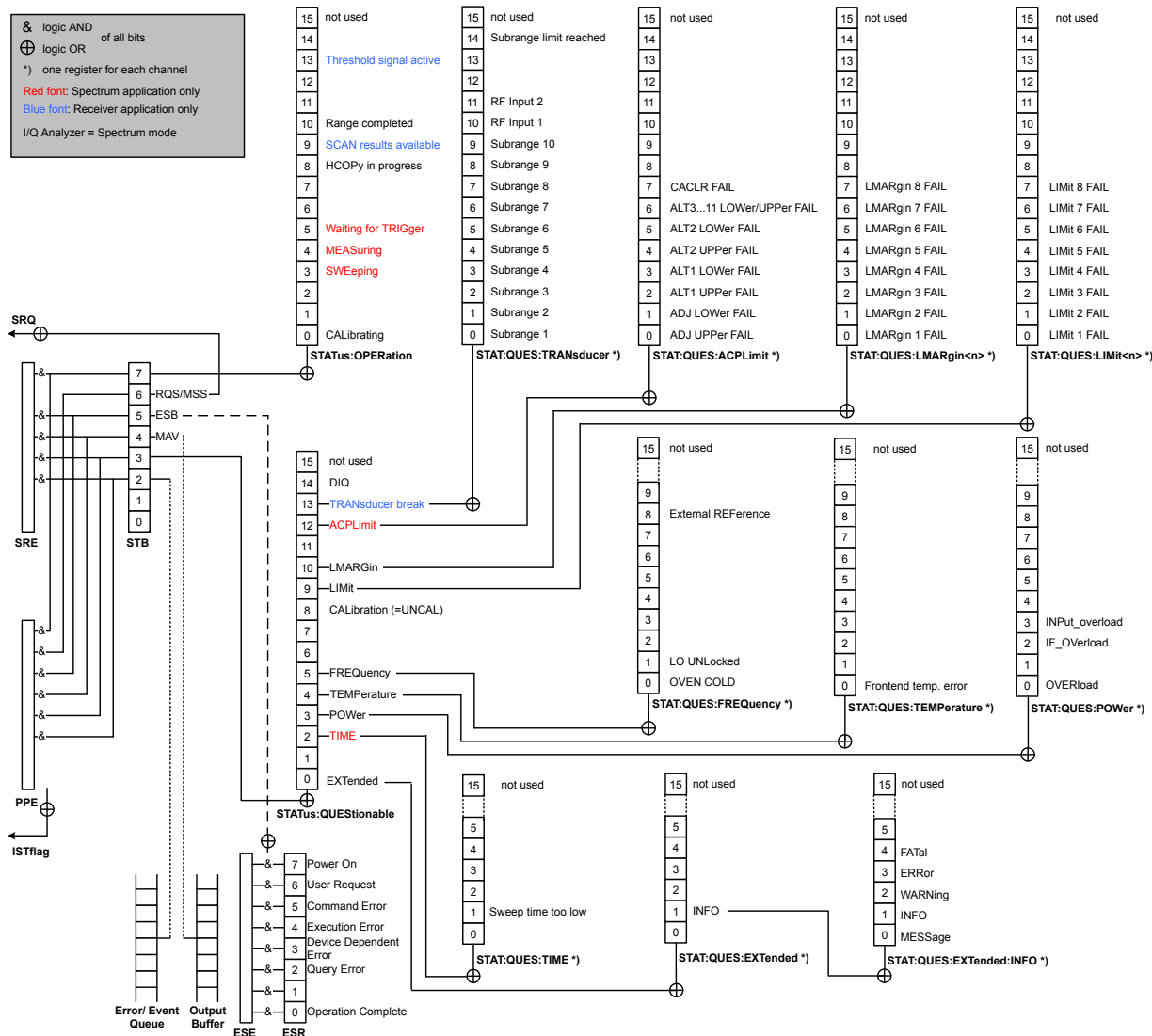

Figure 12-2: Graphical overview of the R&S ESW status registers hierarchy

- **STB, SRE**  
The Status Byte (STB) register and its associated mask register Service Request Enable (SRE) form the highest level of the status reporting system. The STB provides a rough overview of the instrument status, collecting the information of the lower-level registers.
- **ESR, SCPI registers**  
The STB receives its information from the following registers:
  - The Event Status Register (ESR) with the associated mask register standard Event Status Enable (ESE).
  - The STATUS:OPERation and STATUS:QUESTIONable registers which are defined by SCPI and contain detailed information on the instrument.
- **IST, PPE**

The **IST** flag ("Individual Status"), like the **SRQ**, combines the entire instrument status in a single bit. The **PPE** fulfills the same function for the **IST** flag as the **SRE** for the service request.

- **Output buffer**

The output buffer contains the messages the instrument returns to the controller. It is not part of the status reporting system but determines the value of the **MAV** bit in the **STB** and thus is represented in the overview.

All status registers have the same internal structure.



### SRE, ESE

The service request enable register **SRE** can be used as **ENABLE** part of the **STB** if the **STB** is structured according to **SCPI**. By analogy, the **ESE** can be used as the **ENABLE** part of the **ESR**.

#### 12.1.7.2 Structure of a SCPI Status Register

Each standard **SCPI** register consists of 5 parts. Each part has a width of 16 bits and has different functions. The individual bits are independent of each other, i.e. each hardware status is assigned a bit number which is valid for all five parts. Bit 15 (the most significant bit) is set to zero for all parts. Thus the contents of the register parts can be processed by the controller as positive integers.

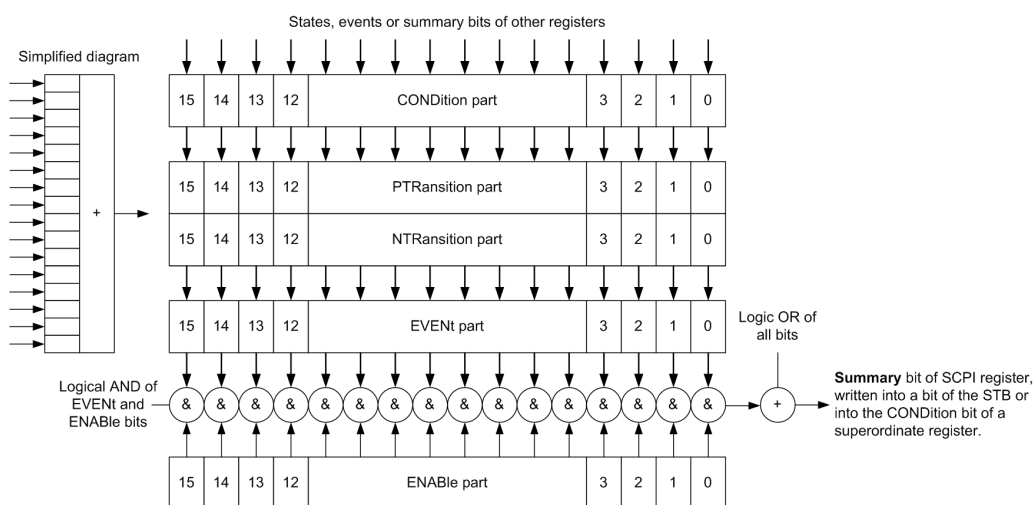

Figure 12-3: The status-register model

#### Description of the five status register parts

The five parts of a **SCPI** register have different properties and functions:

- **CONDition**

The **CONDition** part is written into directly by the hardware or the sum bit of the next lower register. Its contents reflect the current instrument status. This register part can only be read, but not written into or cleared. Its contents are not affected by reading.

- **PTRransition / NTRransition**

The two transition register parts define which state transition of the `CONDition` part (none, 0 to 1, 1 to 0 or both) is stored in the `EVENT` part.

The **Positive-TRransition** part acts as a transition filter. When a bit of the `CONDition` part is changed from 0 to 1, the associated `PTR` bit decides whether the `EVENT` bit is set to 1.

- `PTR` bit =1: the `EVENT` bit is set.
- `PTR` bit =0: the `EVENT` bit is not set.

This part can be written into and read as required. Its contents are not affected by reading.

The **Negative-TRransition** part also acts as a transition filter. When a bit of the `CONDition` part is changed from 1 to 0, the associated `NTR` bit decides whether the `EVENT` bit is set to 1.

- `NTR` bit =1: the `EVENT` bit is set.
- `NTR` bit =0: the `EVENT` bit is not set.

This part can be written into and read as required. Its contents are not affected by reading.

- **EVENT**

The `EVENT` part indicates whether an event has occurred since the last reading, it is the "memory" of the condition part. It only indicates events passed on by the transition filters. It is permanently updated by the instrument. This part can only be read by the user. Reading the register clears it. This part is often equated with the entire register.

- **ENABLE**

The `ENABLE` part determines whether the associated `EVENT` bit contributes to the sum bit (see below). Each bit of the `EVENT` part is "ANDed" with the associated `ENABLE` bit (symbol '&'). The results of all logical operations of this part are passed on to the sum bit via an "OR" function (symbol '+').

`ENABLE` bit = 0: the associated `EVENT` bit does not contribute to the sum bit

`ENABLE` bit = 1: if the associated `EVENT` bit is "1", the sum bit is set to "1" as well.

This part can be written into and read by the user as required. Its contents are not affected by reading.

### Sum bit

The sum bit is obtained from the `EVENT` and `ENABLE` part for each register. The result is then entered into a bit of the `CONDition` part of the higher-order register.

The instrument automatically generates the sum bit for each register. Thus an event can lead to a service request throughout all levels of the hierarchy.

### 12.1.7.3 Contents of the Status Registers

In the following sections, the contents of the status registers are described in more detail.

• Status Byte (STB) and Service Request Enable Register (SRE).....	369
• IST Flag and Parallel Poll Enable Register (PPE).....	370
• Event Status Register (ESR) and Event Status Enable Register (ESE).....	370
• STATus:OPERation Register.....	371
• STATus:QUEStionable Register.....	372
• STATus:QUEStionable:ACPLimit Register.....	373
• STATus:QUEStionable:EXTended Register.....	374
• STATus:QUEStionable:EXTended:INFO Register.....	374
• STATus:QUEStionable:FREQuency Register.....	375
• STATus:QUEStionable:LIMit Register.....	376
• STATus:QUEStionable:LMARgin Register.....	376
• STATus:QUEStionable:POWer Register.....	377
• STATus:QUEStionable:TIME Register.....	378
• STATus:QUEStionable:TRANsducer Register.....	378

### Status Byte (STB) and Service Request Enable Register (SRE)

The `STatus Byte` (STB) is already defined in IEEE 488.2. It provides a rough overview of the instrument status by collecting the pieces of information of the lower registers. A special feature is that bit 6 acts as the sum bit of the remaining bits of the status byte.

The STB can thus be compared with the `CONDition` part of an SCPI register and assumes the highest level within the SCPI hierarchy.

The STB is read using the command `*STB?` or a serial poll.

The `STatus Byte` (STB) is linked to the `Service Request Enable` (SRE) register. Each bit of the STB is assigned a bit in the SRE. Bit 6 of the SRE is ignored. If a bit is set in the SRE and the associated bit in the STB changes from 0 to 1, a service request (SRQ) is generated. The SRE can be set using the command `*SRE` and read using the command `*SRE?`.

**Table 12-7: Meaning of the bits used in the status byte**

Bit No.	Meaning
0...1	Not used
2	Error Queue not empty The bit is set when an entry is made in the error queue. If this bit is enabled by the SRE, each entry of the error queue generates a service request. Thus an error can be recognized and specified in greater detail by polling the error queue. The poll provides an informative error message. This procedure is to be recommended since it considerably reduces the problems involved with remote control.
3	QUESTIONable status register summary bit The bit is set if an <code>EVENT</code> bit is set in the <code>QUESTIONable</code> status register and the associated <code>ENABLE</code> bit is set to 1. A set bit indicates a questionable instrument status, which can be specified in greater detail by querying the <code>STATus:QUEStionable</code> status register.
4	MAV bit (message available) The bit is set if a message is available in the output queue which can be read. This bit can be used to enable data to be automatically read from the instrument to the controller.



Bit No.	Meaning
5	ESB bit Sum bit of the event status register. It is set if one of the bits in the event status register is set and enabled in the event status enable register. Setting of this bit indicates a serious error which can be specified in greater detail by polling the event status register.
6	MSS bit (master status summary bit) The bit is set if the instrument triggers a service request. This is the case if one of the other bits of this registers is set together with its mask bit in the service request enable register SRE.
7	STATUS:OPERation status register summary bit The bit is set if an EVENT bit is set in the OPERATION status register and the associated ENABLE bit is set to 1. A set bit indicates that the instrument is just performing an action. The type of action can be determined by querying the STATUS:OPERation status register.

### IST Flag and Parallel Poll Enable Register (PPE)

As with the SRQ, the IST flag combines the entire status information in a single bit. It can be read by means of a parallel poll (see "Parallel Poll" on page 380) or using the command `*IST?`.

The parallel poll enable register (PPE) determines which bits of the STB contribute to the IST flag. The bits of the STB are "ANDed" with the corresponding bits of the PPE, with bit 6 being used as well in contrast to the SRE. The IST flag results from the "ORing" of all results. The PPE can be set using commands `*PRE` and read using command `*PRE?`.

### Event Status Register (ESR) and Event Status Enable Register (ESE)

The ESR is defined in IEEE 488.2. It can be compared with the EVENT part of a SCPI register. The event status register can be read out using command `*ESR?`.

The ESE corresponds to the ENABLE part of a SCPI register. If a bit is set in the ESE and the associated bit in the ESR changes from 0 to 1, the ESB bit in the STB is set. The ESE register can be set using the command `*ESE` and read using the command `*ESE?`.

**Table 12-8: Meaning of the bits used in the event status register**

Bit No.	Meaning
0	Operation Complete This bit is set on receipt of the command <code>*OPC</code> exactly when all previous commands have been executed.
1	Not used
2	Query Error This bit is set if either the controller wants to read data from the instrument without having sent a query, or if it does not fetch requested data and sends new instructions to the instrument instead. The cause is often a query which is faulty and hence cannot be executed.
3	Device-dependent Error This bit is set if a device-dependent error occurs. An error message with a number between -300 and -399 or a positive error number, which denotes the error in greater detail, is entered into the error queue.

Bit No.	Meaning
4	<p>Execution Error</p> <p>This bit is set if a received command is syntactically correct but cannot be performed for other reasons. An error message with a number between -200 and -300, which denotes the error in greater detail, is entered into the error queue.</p>
5	<p>Command Error</p> <p>This bit is set if a command is received, which is undefined or syntactically incorrect. An error message with a number between -100 and -200, which denotes the error in greater detail, is entered into the error queue.</p>
6	<p>User Request</p> <p>This bit is set when the instrument is switched over to manual control.</p>
7	<p>Power On (supply voltage on)</p> <p>This bit is set on switching on the instrument.</p>

### STATus:OPERation Register

The `STATus:OPERation` register contains information on current activities of the R&S ESW. It also contains information on activities that have been executed since the last read out.

**Table 12-9: Meaning of the bits used in the `STATus:OPERation` register**

Bit No.	Meaning
0	<p>CALibrating</p> <p>This bit is set as long as the instrument is performing a calibration.</p>
1-2	Not used
3	<p>SWEeping</p> <p>Sweep is being performed in base unit (applications are not considered); identical to bit 4 Available in the Spectrum application.</p>
4	<p>MEASuring</p> <p>Measurement is being performed in base unit (applications are not considered); identical to bit 3 Available in the Spectrum application.</p>
5	<p>Waiting for TRigger</p> <p>Instrument is ready to trigger and waiting for trigger signal. Available in the Spectrum application.</p>
6-7	Not used
8	<p>HardCOpy in progress</p> <p>This bit is set while the instrument is printing a hardcopy.</p>
9	<p>SCAN results available</p> <p>This bit is set when a block of scan results is available. Must be enabled by <code>TRAC:FEED:CONTALWays</code>. Available in the Receiver application.</p>

Bit No.	Meaning
10	Range completed In the Spectrum application, this bit is set when a range in the sweep list has been completed if "Stop after Range" has been activated. In the Receiver application, this bit is set when the end of a scan range has been reached. To resume the scan, use <code>INITiate:CONMeas</code> .
11-12	Not used
13	Threshold signal active Available for the Receiver application.
14	Not used
15	This bit is always 0.

### STATus:QUEStionable Register

The STATus:QUEStionable register contains information on instrument states that do not meet the specifications.

You can read out the register with `STAT:QUES:COND` or `STAT:QUES:EVEN`.



The STATus:QUEStionable register "sums up" the information from all subregisters (e.g. bit 2 sums up the information for all STATus:QUEStionable:TIME registers). For some subregisters, there may be separate registers for each active channel. Thus, if a status bit in the STATus:QUEStionable register indicates an error, the error may have occurred in any of the channel-specific subregisters. In this case, you must check the subregister of each channel to determine which channel caused the error. By default, querying the status of a subregister always returns the result for the currently selected channel.

**Table 12-10: Meaning of the bits used in the STATus:QUEStionable register**

Bit No.	Meaning
0 - 1	Unused
2	TIME This bit is set if a time error occurs in any of the active channels. The <a href="#">STATus:QUEStionable:TIME Register</a> provides more information on the error type. Available in the Spectrum application.
3	POWER This bit is set if the measured power level in any of the active channels is questionable. The <a href="#">STATus:QUEStionable:POWER Register</a> provides more information on the error type.
4	TEMPERature This bit is set if the temperature is questionable.
5	FREQUency This bit is set if there is anything wrong with the frequency of the local oscillator or the reference frequency in any of the active channels. The <a href="#">STATus:QUEStionable:FREQUency Register</a> provides more information on the error type.

Bit No.	Meaning
6 - 7	Unused
8	CALibration This bit is set if the R&S ESW is unaligned ("UNCAL" display)
9	LIMit This bit is set if a limit value is violated in any of the active channels in any window. The <a href="#">STATus:QUEStionable:LIMit Register</a> provides more information on the error type.
10	LMARgin This bit is set if a margin is violated in any of the active channels in any window. The <a href="#">STATus:QUEStionable:LMARgin Register</a> provides more information on the error type.
11	SYNC (device-specific) This bit is set if the R&S ESW is not synchronized to the signal that is applied. The R&S ESW is not synchronized if the results deviate too much from the expected value during premeasurements
12	ACPLimit This bit is set if a limit during ACLR measurements is violated in any of the active channels. The <a href="#">STATus:QUEStionable:ACPLimit Register</a> provides more information on the error type. Available in the Spectrum application.
13	TRANsducer break This bit is set if a transducer break occurs and indicates the next range. The " <a href="#">STATus:QUEStionable:TRANsducer Register</a> " on page 378 provides more information on the error type.
14	Unused
15	This bit is always 0.

### STATus:QUEStionable:ACPLimit Register

Available for the Spectrum application.

The STATus:QUEStionable:ACPLimit register contains information about the results of a limit check during ACLR measurements. A separate ACPLimit register exists for each active channel.

You can read out the register with [STATus:QUEStionable:ACPLimit:CONDition?](#) or [STATus:QUEStionable:ACPLimit\[:EVENT\]?](#)

**Table 12-11: Meaning of the bits used in the STATus:QUEStionable:ACPLimit register**

Bit No.	Meaning
0	ADJ UPPer FAIL This bit is set if the limit is exceeded in the <b>upper adjacent</b> channel
1	ADJ LOWer FAIL This bit is set if the limit is exceeded in the <b>lower adjacent</b> channel.
2	ALT1 UPPer FAIL This bit is set if the limit is exceeded in the <b>upper 1st alternate</b> channel.

Bit No.	Meaning
3	ALT1 LOWEr FAIL This bit is set if the limit is exceeded in the <b>lower 1st alternate</b> channel.
4	ALT2 UPPer FAIL This bit is set if the limit is exceeded in the <b>upper 2nd alternate</b> channel.
5	ALT2 LOWEr FAIL This bit is set if the limit is exceeded in the <b>lower 2nd alternate</b> channel.
6	ALT3 ... 11 LOWEr/UPPer FAIL This bit is set if the limit is exceeded in one of the lower or upper alternate channels 3 ... 11.
7	CACLR FAIL This bit is set if the CACLR limit is exceeded in one of the gap channels.
8	GAP ACLR FAIL This bit is set if the ACLR limit is exceeded in one of the gap channels.
9 to 14	Unused
15	This bit is always 0.

### STATUS:QUESTIONable:EXTended Register

The `STATUS:QUESTIONable:EXTended` register contains further status information not covered by the other status registers of the R&S ESW. A separate `EXTended` register exists for each active channel.

You can read out the register with `STATUS:QUESTIONable:EXTended:CONDition?` or `STATUS:QUESTIONable:EXTended[:EVENT]?`

**Table 12-12: Meaning of the bits used in the STATUS:QUESTIONable:EXTended register**

Bit No.	Meaning
0	not used
1	INFO This bit is set if a status message is available for the application. Which type of message occurred is indicated in the <code>STATUS:QUESTIONable:EXTended:INFO Register</code> .
2 to 14	Unused
15	This bit is always 0.

### STATUS:QUESTIONable:EXTended:INFO Register

The `STATUS:QUESTIONable:EXTended:INFO` register contains information on the type of messages that occur during operation of the R&S ESW. A separate `INFO` register exists for each active channel.

You can read out the register with `STATUS:QUESTIONable:EXTended:INFO:CONDition?` or `STATUS:QUESTIONable:EXTended:INFO[:EVENT]?`. You can query all messages that occur for a specific channel using the command `SYSTEM:ERROR:EXTended?` on page 659.

**Table 12-13: Meaning of the bits used in the STATUS:QUESTIONable:EXTended:INFO register**

Bit No.	Meaning
0	MESSage This bit is set if event or state has occurred that may lead to an error during further operation.
1	INFO This bit is set if an informational status message is available for the application.
2	WARNing This bit is set if an irregular situation occurs during measurement, e.g. the settings no longer match the displayed results, or the connection to an external device was interrupted temporarily.
3	ERRor This bit is set if an error occurs during a measurement, e.g. due to missing data or wrong settings, so that the measurement cannot be completed correctly.
4	FATal This bit is set if a serious error occurs in the application and regular operation is no longer possible.
5 to 14	Unused
15	This bit is always 0.

**STATUS:QUESTIONable:FREQUENCY Register**

The STATUS:QUESTIONable:FREQUENCY register contains information about the condition of the local oscillator and the reference frequency. A separate frequency register exists for each active channel.

You can read out the register with `STATUS:QUESTIONable:FREQUENCY:CONDition?` or `STATUS:QUESTIONable:FREQUENCY[:EVENT]?`.

**Table 12-14: Meaning of the bits used in the STATUS:QUESTIONable:FREQUENCY register**

Bit No.	Meaning
0	OVEN COLD This bit is set if the reference oscillator has not yet attained its operating temperature. "OCXO" is displayed.
1	LO UNLocked This bit is set if the local oscillator no longer locks. "LOUNL" is displayed.
2 to 7	Not used
8	EXTernalREFerence This bit is set if you have selected an external reference oscillator but did not connect a useable external reference source. In that case the synthesizer can not lock. The frequency in all probability is not accurate.
9 to 14	Not used
15	This bit is always 0.

**STATus:QUESTionable:LIMit Register**

The STATus:QUESTionable:LIMit register contains information about the results of a limit check when you are working with limit lines.

A separate LIMit register exists for each active channel and for each window.

*Table 12-15: Meaning of the bits used in the STATus:QUESTionable:LIMit register*

Bit No.	Meaning
0	LIMit 1 FAIL This bit is set if limit line 1 is violated.
1	LIMit 2 FAIL This bit is set if limit line 2 is violated.
2	LIMit 3 FAIL This bit is set if limit line 3 is violated.
3	LIMit 4 FAIL This bit is set if limit line 4 is violated.
4	LIMit 5 FAIL This bit is set if limit line 5 is violated.
5	LIMit 6 FAIL This bit is set if limit line 6 is violated.
6	LIMit 7 FAIL This bit is set if limit line 7 is violated.
7	LIMit 8 FAIL This bit is set if limit line 8 is violated.
8 to 14	Unused
15	This bit is always 0.

**STATus:QUESTionable:LMARgin Register**

This register contains information about the observance of limit margins.

A separate LMARgin register exists for each active channel and for each window.

It can be read using the commands

STATus:QUESTionable:LMARgin:CONDition? and

STATus:QUESTionable:LMARgin[:EVENT]?

*Table 12-16: Meaning of the bits used in the STATus:QUESTionable:LMARgin register*

Bit No.	Meaning
0	LMARgin 1 FAIL This bit is set if limit margin 1 is violated.
1	LMARgin 2 FAIL This bit is set if limit margin 2 is violated.

Bit No.	Meaning
2	LMARgin 3 FAIL This bit is set if limit margin 3 is violated.
3	LMARgin 4 FAIL This bit is set if limit margin 4 is violated.
4	LMARgin 5 FAIL This bit is set if limit margin 5 is violated.
5	LMARgin 6 FAIL This bit is set if limit margin 6 is violated.
6	LMARgin 7 FAIL This bit is set if limit margin 7 is violated.
7	LMARgin 8 FAIL This bit is set if limit margin 8 is violated.
8 to 14	Not used
15	This bit is always 0.

### STATUS:QUESTIONABLE:POWER Register

The `STATUS:QUESTIONABLE:POWER` register contains information about possible overload situations that may occur during operation of the R&S ESW. A separate power register exists for each active channel.

You can read out the register with `STATUS:QUESTIONABLE:POWER:CONDITION?` or `STATUS:QUESTIONABLE:POWER[:EVENT]?`

**Table 12-17: Meaning of the bits used in the STATUS:QUESTIONABLE:POWER register**

Bit No.	Meaning
0	OVERload This bit is set if an overload occurs at the RF input, causing signal distortion but not yet causing damage to the device. The R&S ESW displays the keyword "RF OVLD".
1	Unused
2	IF_Overload This bit is set if an overload occurs in the IF path. The R&S ESW displays the keyword "IF OVLD".
3	Input Overload This bit is set if the signal level at the RF input connector exceeds the maximum. The RF input is disconnected from the input mixer to protect the device. In order to re-enable measurement, decrease the level at the RF input connector and reconnect the RF input to the mixer input. The R&S ESW displays the keyword "INPUT OVLD". (Available in the Spectrum application.)



Bit No.	Meaning
4 to 14	Unused
15	This bit is always 0.

### STATUS:QUESTIONABLE:TIME Register

Available for the Spectrum application.

The STATUS:QUESTIONABLE:TIME register contains information about possible time errors that may occur during operation of the R&S ESW. A separate time register exists for each active channel.

*Table 12-18: Meaning of the bits used in the STATUS:QUESTIONABLE:TIME register*

Bit No.	Meaning
0	not used
1	Sweep time too low This bit is set if the sweep time is too low.
2 to 14	Unused
15	This bit is always 0.

### STATUS:QUESTIONABLE:TRANSDUCER Register

Available for the Receiver application.

The STATUS:QUESTIONABLE:TRANSDUCER register contains information about the state and condition of measurements with transducer sets. A separate TRANSDUCER register exists for each active channel.

It indicates that a transducer break has been reached. It also indicates the next range that is to be swept. You can continue the sweep with `INITiate<n>:CONMeas` on page 427.

You can read out the register with `STATUS:QUESTIONABLE:TRANSDUCER:CONDITION?` or `STATUS:QUESTIONABLE:TRANSDUCER[:EVENT]?` on page 666.

*Table 12-19: Meaning of the bits used in the STATUS:QUESTIONABLE:ACPLimit register*

Bit No.	Meaning
0	Range 1 This bit is set if subrange 1 has been reached.
1	Range 2 This bit is set if subrange 2 has been reached.
2	Range 3 This bit is set if subrange 3 has been reached.
3	Range 4 This bit is set if subrange 4 has been reached.
4	Range 5 This bit is set if subrange 5 has been reached.

Bit No.	Meaning
5	Range 6 This bit is set if subrange 6 has been reached.
6	Range 7 This bit is set if subrange 7 has been reached.
7	Range 8 This bit is set if subrange 8 has been reached.
8	Range 9 This bit is set if subrange 9 has been reached.
9	Range 10 This bit is set if subrange 10 has been reached.
10	RF Input 1 This bit is set if the transducer has been assigned to RF input 1.
11	RF Input 2 This bit is set if the transducer has been assigned to RF input 2.
12 to 13	Unused
14	Subrange limit This bit is set when the transducer is at the point of changeover from one subrange to another.
15	This bit is always 0.

#### 12.1.7.4 Application of the Status Reporting System

The purpose of the status reporting system is to monitor the status of one or several devices in a measuring system. To do this and react appropriately, the controller must receive and evaluate the information of all devices. The following standard methods are used:

- **Service request** (SRQ) initiated by the instrument
- **Serial poll** of all devices in the bus system, initiated by the controller in order to find out who sent a SRQ and why
- **Parallel poll** of all devices
- Query of a **specific instrument status** by means of commands
- Query of the **error queue**

##### Service Request

Under certain circumstances, the instrument can send a service request (SRQ) to the controller. A service request is a request from an instrument for information, advice or treatment by the controller. Usually this service request initiates an interrupt at the controller, to which the control program can react appropriately. As evident from [Figure 12-2](#), an SRQ is always initiated if one or several of bits 2, 3, 4, 5 or 7 of the status byte are set and enabled in the SRE. Each of these bits combines the information of a further register, the error queue or the output buffer. The `ENABLE` parts of the status registers can be set such that arbitrary bits in an arbitrary status register initiate an

SRQ. In order to make use of the possibilities of the service request effectively, all bits should be set to "1" in enable registers SRE and ESE.

The service request is the only possibility for the instrument to become active on its own. Each controller program should cause the instrument to initiate a service request if errors occur. The program should react appropriately to the service request.

#### Use of the command \*OPC to generate an SRQ at the end of a sweep

1. `CALL InstrWrite(analyzer, "*ESE 1")` 'Set bit 0 in the ESE (Operation Complete)
2. `CALL InstrWrite(analyzer, "*SRE 32")` 'Set bit 5 in the SRE (ESB)
3. `CALL InstrWrite(analyzer, "*INIT;*OPC")` 'Generate an SRQ after operation complete

After its settings have been completed, the instrument generates an SRQ.

#### Serial Poll

In a serial poll, just as with command \*STB, the status byte of an instrument is queried. However, the query is realized via interface messages and is thus clearly faster.

The serial poll method is defined in IEEE 488.1 and used to be the only standard possibility for different instruments to poll the status byte. The method also works for instruments which do not adhere to SCPI or IEEE 488.2.

The serial poll is mainly used to obtain a fast overview of the state of several instruments connected to the controller.

#### Parallel Poll

In a parallel poll, up to eight instruments are simultaneously requested by the controller using a single command to transmit 1 bit of information each on the data lines, i.e., to set the data line allocated to each instrument to a logical "0" or "1".

In addition to the SRE register, which determines the conditions under which an SRQ is generated, there is a Parallel Poll Enable register (PPE) which is ANDed with the STB bit by bit, considering bit 6 as well. This register is ANDed with the STB bit by bit, considering bit 6 as well. The results are ORed, the result is possibly inverted and then sent as a response to the parallel poll of the controller. The result can also be queried without parallel poll using the command \*IST?.

The instrument first has to be set for the parallel poll using the command PPC. This command allocates a data line to the instrument and determines whether the response is to be inverted. The parallel poll itself is executed using PPE.

The parallel poll method is mainly used to find out quickly which one of the instruments connected to the controller has sent a service request. To this effect, SRE and PPE must be set to the same value.

#### Query of an instrument status

Each part of any status register can be read using queries. There are two types of commands:

- The common commands `*ESR?`, `*IDN?`, `*IST?`, `*STB?` query the higher-level registers.
- The commands of the `STATus` system query the SCPI registers (`STATus:QUEStionable...`)

The returned value is always a decimal number that represents the bit pattern of the queried register. This number is evaluated by the controller program.

Queries are usually used after an SRQ in order to obtain more detailed information on the cause of the SRQ.

### Decimal representation of a bit pattern

The STB and ESR registers contain 8 bits, the SCPI registers 16 bits. The contents of a status register are specified and transferred as a single decimal number. To make this possible, each bit is assigned a weighted value. The decimal number is calculated as the sum of the weighted values of all bits in the register that are set to 1.

Bits	0	1	2	3	4	5	6	7	...
Weight	1	2	4	8	16	32	64	128	...

#### Example:

The decimal value  $40 = 32 + 8$  indicates that bits no. 3 and 5 in the status register (e.g. the `QUEStionable` status summary bit and the `ESB` bit in the `STatus Byte`) are set.

### Error Queue

Each error state in the instrument leads to an entry in the error queue. The entries of the error queue are detailed plain text error messages that can be looked up in the Error Log or queried via remote control using `SYSTem:ERRor[:NEXT]?`. Each call of `SYSTem:ERRor[:NEXT]?` provides one entry from the error queue. If no error messages are stored there any more, the instrument responds with 0, "No error".

The error queue should be queried after every SRQ in the controller program as the entries describe the cause of an error more precisely than the status registers. Especially in the test phase of a controller program the error queue should be queried regularly since faulty commands from the controller to the instrument are recorded there as well.

#### 12.1.7.5 Reset Values of the Status Reporting System

The following table contains the different commands and events causing the status reporting system to be reset. None of the commands, except `*RST` and `SYSTem:PRESet`, influence the functional instrument settings. In particular, `DCL` does not change the instrument settings.

Table 12-20: Resetting the status reporting system

Event	Switching on supply voltage		DCL, SDC (Device Clear, Selected Device Clear)	*RST or SYS-Tem:PRE Set	STA-Tus:PRE-Set	*CLS
	Power-On-Status-Clear					
Effect	0	1				
Clear STB, ESR	-	yes	-	-	-	yes
Clear SRE, ESE	-	yes	-	-	-	-
Clear PPE	-	yes	-	-	-	-
Clear EVENT parts of the registers	-	yes	-	-	-	yes
Clear ENABLE parts of all OPERation and QUEStionable registers; Fill ENABLE parts of all other registers with "1".	-	yes	-	-	yes	-
Fill PTRansition parts with "1"; Clear NTRansition parts	-	yes	-	-	yes	-
Clear error queue	yes	yes	-	-	-	yes
Clear output buffer	yes	yes	yes	1)	1)	1)
Clear command processing and input buffer	yes	yes	yes	-	-	-

1) The first command in a command line that immediately follows a <PROGRAM MESSAGE TERMINATOR> clears the output buffer.

## 12.1.8 General Programming Recommendations

### Initial instrument status before changing settings

Manual operation is designed for maximum possible operating convenience. In contrast, the priority of remote control is the "predictability" of the instrument status. Thus, when a command attempts to define incompatible settings, the command is ignored and the instrument status remains unchanged, i.e. other settings are not automatically adapted. Therefore, control programs should always define an initial instrument status (e.g. using the \*RST command) and then implement the required settings.

### Command sequence

As a general rule, send commands and queries in different program messages. Otherwise, the result of the query may vary depending on which operation is performed first (see also [Chapter 12.1.6.1, "Preventing Overlapping Execution"](#), on page 364).

### Reacting to malfunctions

The service request is the only possibility for the instrument to become active on its own. Each controller program should instruct the instrument to initiate a service request in case of malfunction. The program should react appropriately to the service request.

### Error queues

The error queue should be queried after every service request in the controller program as the entries describe the cause of an error more precisely than the status registers. Especially in the test phase of a controller program the error queue should be queried regularly since faulty commands from the controller to the instrument are recorded there as well.

## 12.2 GPIB Languages

The R&S ESW analyzer family supports a subset of the GPIB commands used by other devices. Thus it can emulate other devices in order to use existing remote control programs.

The device model to be emulated is selected manually using "SETUP > Network + Remote > GPIB tab > Language". Via the GPIB interface using the [SYSTem: LANGuage](#) on page 653 command.

In order to emulate device models that are not part of the selection list of the GPIB "Language" setting, you can modify the identification string received in response to the ID command ("Identification String" setting). Thus, any device model whose command set is compatible with one of the supported device models can be emulated.

### Supported languages

Language	Comment
SCPI	
71100C	Compatible to 8566A/B
71200C	Compatible to 8566A/B
71209A	Compatible to 8566A/B
8560E	
8561E	
8562E	
8563E	
8564E	
8565E	
8566A	Command sets A and B are available. Command sets A and B differ in the rules regarding the command structure.

Language	Comment
8566B	
8568A	Command sets A and B are available. Command sets A and B differ in the rules regarding the command structure.
8568A_DC	Uses DC input coupling by default if supported by the instrument
8568B	Command sets A and B are available. Command sets A and B differ in the rules regarding the command structure.
8568B_DC	Uses DC input coupling by default if supported by the instrument
8591E	Compatible to 8594E
8594E	Command sets A and B are available. Command sets A and B differ in the rules regarding the command structure.
PSA89600	
PSA	

**Notes:**

- If you select a language other than "SCPI", the GPIB address is set to 18 if it was 20 before.
- The Start/stop frequency, reference level and number of sweep points are adapted to the selected instrument model.
- When you switch between remote control languages, the following settings or changes are made:  
**SCPI:**  
The instrument performs a PRESET.  
**8566A/B, 8568A/B, 8594E; FSEA, FSEB, FSEM; FSEK:**
  - The instrument performs a PRESET.
  - The following instrument settings are changed:

**Table 12-21: Instrument settings for emulation of 8566A/B, 8568A/B, 8594E; FSEA, FSEB, FSEM; FSEK instruments**

Model	# of Trace Points	Start Freq.	Stop Freq.	Ref Level	Input Coupling
8566A/B	1001	2 GHz	22 GHz	0 dBm	AC
8568A/B	1001	0 Hz	1.5 GHz	0 dBm	AC
8560E	601	0 Hz	2.9 GHz	0 dBm	AC
8561E	601	0 Hz	6.5 GHz	0 dBm	AC
8562E	601	0 Hz	13.2 GHz	0 dBm	AC
8563E	601	0 Hz	26.5 GHz	0 dBm	AC
8564E	601	0 Hz	40 GHz	0 dBm	AC
8565E	601	0 Hz	50 GHz	0 dBm	AC
8594E	401	0 Hz	3 GHz	0 dBm	AC

**Note:** The stop frequency indicated in the table may be limited to the corresponding frequency of the R&S ESW, if required.

## 12.3 The IECWIN Tool

The R&S ESW is delivered with *IECWIN* installed, an auxiliary tool provided free of charge by R&S. IECWIN is a program to send SCPI commands to a measuring instrument either interactively or from a command script.



The R&S IECWIN32 tool is provided free of charge. The functionality may change in a future version without notice.

---

IECWIN offers the following features:

- Connection to instrument via several interfaces/protocols (GPIB, VISA, named pipe (if IECWIN is run on the instrument itself), RSIB)
- Interactive command entry
- Browsing available commands on the instrument
- Error checking following every command
- Execution of command scripts
- Storing binary data to a file
- Reading binary data from a file
- Generation of a log file

For command scripts, IECWIN offers the following features:

- Synchronization with the instrument on every command
- Checking expected result for query commands (as string or numeric value)
- Checking for expected errors codes
- Optional pause on error
- Nested command scripts
- Single step mode
- Conditional execution, based on the \*IDN and \*OPT strings



You can use the IECWIN to try out the programming examples provided in the R&S ESW User Manuals.

---

### Starting IECWIN

IECWIN is available from the Windows "Start" menu on the R&S ESW, or by executing the following file:

```
C:\Program Files (x86)\Rohde-Schwarz\ESW\<<version>\iecwin32.exe
```



You can also copy the program to any Windows PC or laptop. Simply copy the `iecwin32.exe`, `iecwin.chm` and `rsib32.dll` files from the location above to the same folder on the target computer.

When the tool is started, a "Connection settings" dialog box is displayed. Define the connection from the computer the IECWIN tool is installed on to the R&S ESW you want to control. If you are using the tool directly on the R&S ESW, you can use an NT Pipe (COM Parser) connection, which requires no further configuration. For help on setting up other connection types, check the tool's online help (by clicking the "Help" button in the dialog box).



The IECWIN offers an online help with extensive information on how to work with the tool.

## 12.4 Network and Remote Control Settings

**Access:** [SETUP] > "Network + Remote"



### Network settings in secure user mode

Be sure to store all network settings before [SecureUser Mode](#) is enabled; see [Chapter 2.7, "Protecting Data Using the Secure User Mode"](#), on page 37.

If the currently stored network settings are not suitable, you must correct them each time you switch on the R&S ESW in secure user mode, as the settings are not stored permanently in this case.

The remote commands required to define these settings are described in [Chapter 13.9.7, "Network and Remote Control Configuration"](#), on page 649.

Step-by-step instructions are provided in [Chapter 12.5, "How to Set Up a Network and Remote Control"](#), on page 397.

- [General Network Settings](#)..... 386
- [GPIB Settings](#)..... 388
- [Compatibility Settings](#)..... 390
- [LXI Settings](#)..... 393
- [Remote Errors](#)..... 395
- [Returning to Manual Mode \("Local"\)](#)..... 396

### 12.4.1 General Network Settings

**Access:** [SETUP] > "Network + Remote" > "Network" tab

The R&S ESW can be operated in a local area network (LAN), for example to control the instrument from a remote PC or use a network printer.

**NOTICE**

**Risk of network problems**

All parameters can be edited here; however, beware that changing the computer name has major effects in a network.

For details, see [Chapter 12.5, "How to Set Up a Network and Remote Control"](#), on page 397.



**Network settings in secure user mode**

Be sure to store all network settings before [SecureUser Mode](#) is enabled; see [Chapter 2.7, "Protecting Data Using the Secure User Mode"](#), on page 37.

If the currently stored network settings are not suitable, you must correct them each time you switch on the R&S ESW in secure user mode, as the settings are not stored permanently in this case.

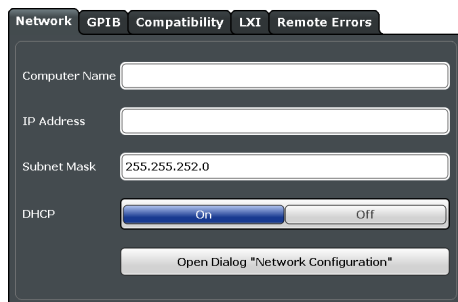

[Computer Name](#).....387

[IP Address](#).....388

[Subnet Mask](#).....388

[DHCP](#).....388

[Network Configuration](#).....388

**Computer Name**

Each instrument is delivered with an assigned computer name, but this name can be changed. The naming conventions of Windows apply. If too many characters and/or numbers are entered, an error message is displayed in the status line.

The default instrument name is a non-case-sensitive string with the following syntax:

<Type><variant>-<serial\_number>

For example ESW26-123456

The serial number can be found on the rear panel of the instrument. It is the third part of the device ID printed on the bar code sticker:



**IP Address**

Defines the IP address. The TCP/IP protocol is preinstalled with the IP address 10.0.0.10. If the DHCP server is available ("DHCP On"), the setting is read-only.

The IP address consists of four number blocks separated by dots. Each block contains 3 numbers in maximum (e.g. 100.100.100.100), but also one or two numbers are allowed in a block (as an example see the preinstalled address).

**Subnet Mask**

Defines the subnet mask. The TCP/IP protocol is preinstalled with the subnet mask 255.255.255.0. If the DHCP server is available ("DHCP On"), this setting is read-only.

The subnet mask consists of four number blocks separated by dots. Each block contains 3 numbers in maximum (e.g. 100.100.100.100), but also one or two numbers are allowed in a block (as an example see the preinstalled address).

**DHCP**

Switches between DHCP server available (On) or not available (Off). If a DHCP server is available in the network, the IP address and subnet mask of the instrument are obtained automatically from the DHCP server.

**Network Configuration**

Opens the standard Windows "Network Configuration" dialog box for further configuration.

**12.4.2 GPIB Settings**

**Access:** [SETUP] > "Network + Remote" > "GPIB" tab

Alternatively to connecting the R&S ESW to a LAN, the GPIB interface can be used to connect a remote PC. For details see [Chapter 12.1.1.2, "GPIB Interface \(IEC 625/IEEE 418 Bus Interface\)"](#), on page 350).

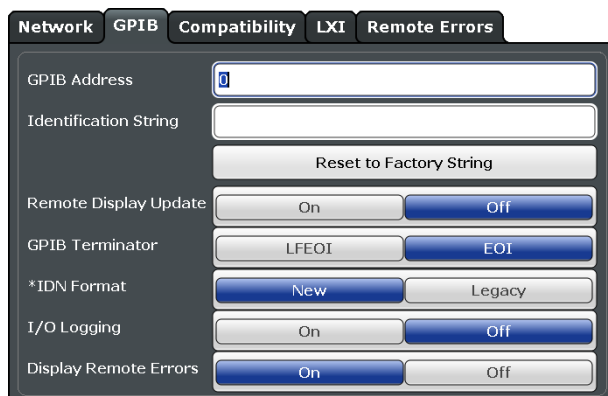

GPIB Address..... 389

Identification String.....389

Reset to Factory String..... 389

Remote Display Update..... 389

GPIB Terminator.....389

*IDN Format.....	390
I/O Logging.....	390
Display Remote Errors.....	390

### GPIB Address

Defines the GPIB address. Values from 0 to 30 are allowed. The default address is 20.

Remote command:

`SYSTem:COMMunicate:GPIB[:SELF]:ADDRess` on page 650

### Identification String

Defines the identification string for the R&S ESW which is provided as a response to the \*IDN? query. Maximum 36 characters are allowed.

Remote command:

`SYSTem:IDENtify[:STRing]` on page 653

### Reset to Factory String

Restores the default identification string. Each R&S ESW has a unique ID according to the following syntax:

Rohde&Schwarz,ESW,<Unique number>

Remote command:

`SYSTem:IDENtify:FACTory` on page 652

### Remote Display Update

Defines whether the display of the R&S ESW is updated when changing from manual operation to remote control.

Turning off the display update function improves performance during remote control.

**Note:** Usually, this function remains available on the display during remote operation. However, it can be disabled remotely. In this case, the display is not updated during remote operation, and cannot be turned on again locally until local operation is resumed.

Remote command:

`SYSTem:DISPlay:UPDate` on page 651

### GPIB Terminator

Changes the GPIB receive terminator.

"LFEOI" According to the standard, the terminator in ASCII is <LF> and/or <EOI>.

"EOI" For binary data transfers (e.g. trace data) from the control computer to the instrument, the binary code used for <LF> might be included in the binary data block, and therefore should not be interpreted as a terminator in this particular case. This can be avoided by using only the receive terminator `EOI`.

Remote command:

`SYSTem:COMMunicate:GPIB[:SELF]:RTERminator` on page 650

**\*IDN Format**

Defines the response format to the remote command `*IDN?` (see `*IDN?` on page 419). This function is intended for re-use of existing control programs together with the R&S ESW.

"Leg" Legacy format, as in the R&S FSP/FSU/FSQ family.

"New" R&S ESW format.

Remote command:

`SYSTem:FORMat:IDENT` on page 660

**I/O Logging**

Activates or deactivates the SCPI error log function. All remote control commands received by the R&S ESW are recorded in a log file. The files are named according to the following syntax:

`C:\R_S\INSTR\ScpiLogging\ScpiLog.<no.>`

where `<no.>` is a sequential number

A new log file is started each time logging was stopped and is restarted.

Logging the commands may be extremely useful for debug purposes, e.g. in order to find misspelled keywords in control programs.

Remote command:

`SYSTem:CLOGging` on page 610

**Display Remote Errors**

Activates and deactivates the display of errors that occur during remote operation of the R&S ESW. If activated, the R&S ESW displays a message box at the bottom of the screen that contains the type of error and the command that caused the error.



The error message remains in place when you switch to "Local" mode. To close the message box, select the  "Close" icon.

Only the most recent error is displayed in remote mode. However, in local mode, all errors that occurred during remote operation are listed in a separate tab of the "Network + Remote" dialog box (see [Chapter 12.4.5, "Remote Errors"](#), on page 395).

Remote command:

`SYSTem:ERRor:DISPlay` on page 651

`SYSTem:ERRor:CLEar:REMote` on page 651

**12.4.3 Compatibility Settings**

The R&S ESW can emulate the GPIB interface of other signal and spectrum analyzers, e.g. in order to use existing control applications.



**Compatibility with former R&S signal and spectrum analyzers**

As a rule, the R&S ESW supports most commands from previous R&S signal and spectrum analyzers such as the FSQ, FSP, FSU, or FSV. However, the default values, in particular the number of sweep points or particular bandwidths, may vary. Therefore, the R&S ESW can emulate these other devices, including their default values, in order to repeat previous measurements or support existing control applications as in legacy systems.

The required settings are configured in the "Compatibility" tab of the "Network +Remote" dialog box.

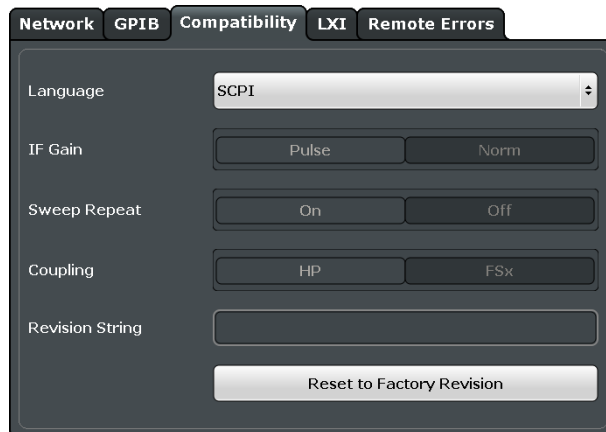

Language..... 391  
 IF Gain..... 392  
 Sweep Repeat.....392  
 Coupling..... 392  
 Wideband..... 392  
 Revision String..... 393  
 Resetting the Factory Revision..... 393

**Language**

Defines the system language used to control the instrument.

For details on the available GPIB languages, see [Chapter 13.12, "Reference: GPIB Commands of Emulated HP Models"](#), on page 676.

**Note:** Emulating previous R&S signal and spectrum analyzers. This function is also used to emulate previous R&S signal and spectrum analyzers.

As a rule, the R&S ESW supports most commands from previous R&S signal and spectrum analyzers such as the FSQ, FSP, FSU, or FSV. However, the default values, in particular the number of sweep points or particular bandwidths, may vary. Therefore, the R&S ESW can emulate these other devices, including their default values, in order to repeat previous measurements or support existing control applications as in legacy systems.

**Note:** For PSA89600 emulation, the option is indicated as "B7J" for the \*OPT? query ("B7J, 140" or "B7J, 122" if [Wideband](#) is activated, see [SYSTEM:PSA:WIDeband](#) on page 654).

Remote command:

[SYSTem:LANGuage](#) on page 653

### IF Gain

Configures the internal IF gain settings in HP emulation mode due to the application needs. This setting is only taken into account for resolution bandwidth < 300 kHz.

NORM	Optimized for high dynamic range, overload limit is close to reference level.
PULS	Optimized for pulsed signals, overload limit up to 10 dB above reference level.

This setting is only available if an HP language is selected (see ["Language"](#) on page 391).

Remote command:

[SYSTem:IFGain:MODE](#) on page 652

### Sweep Repeat

Controls a repeated sweep of the E1 and MKPK HI HP model commands (for details on the commands refer to [Chapter 13.12, "Reference: GPIB Commands of Emulated HP Models"](#), on page 676). If the repeated sweep is OFF, the marker is set without sweeping before.

**Note:** In single sweep mode, switch off this setting before you set the marker via the E1 and MKPK HI commands in order to avoid sweeping again.

This setting is only available if a HP language is selected (see ["Language"](#) on page 391).

Remote command:

[SYSTem:RSweep](#) on page 656

### Coupling

Controls the default coupling ratios in the HP emulation mode for:

- span and resolution bandwidth (Span/RBW)
- resolution bandwidth and video bandwidth (RBW/VBW)

For FSx, the standard parameter coupling of the instrument is used. As a result, in most cases a shorter sweep time is used than in case of HP.

This setting is only available if a HP language is selected (see ["Language"](#) on page 391).

Remote command:

[SYSTem:HPCoupling](#) on page 652

### Wideband

This setting defines which option is returned when the \*OPT? query is executed, depending on the state of the wideband option.

It is only available for PSA89600 emulation.

"Off"	No wideband is used. The option is indicated as "B7J".
"40 MHz"	The 40 MHz wideband is used. The option is indicated as "B7J, 140".

"80 MHz"            The 80 MHz wideband is used.  
                         The option is indicated as "B7J, 122".

Remote command:

[SYSTem:PSA:WIDeband](#) on page 654

### Revision String

Defines the response to the `REV?` query for the revision number (HP emulation only, see ["GPIB Address"](#) on page 389). Max. 36 characters are allowed.

Remote command:

[SYSTem:REVision\[:STRing\]](#) on page 655

### Resetting the Factory Revision

Resets the response to the `REV?` query for the revision number to the factory default (HP emulation only, see ["Language"](#) on page 391).

Remote command:

[SYSTem:REVision:FACTory](#) on page 655

## 12.4.4 LXI Settings

**Access:** [SETUP] > "Network + Remote" > "LXI" tab

On the R&S ESW the LXI Class C functionality is already installed and enabled; thus, the instrument can be accessed via any web browser (e.g. the Microsoft Internet Explorer) to perform the following tasks:

- modifying network configurations
- modifying device configurations
- monitoring connections from the device to other devices

The "LXI" tab of the "Network + Remote" dialog box provides basic LXI functions and information for the R&S ESW.

Alternatively, you can change the LAN settings using the LXI Web browser interface.

For details see [Chapter 12.5.1.4, "How to Configure the LAN Using the LXI Web Browser Interface"](#), on page 401.

Only user accounts with administrator rights are able to use LXI functionality.



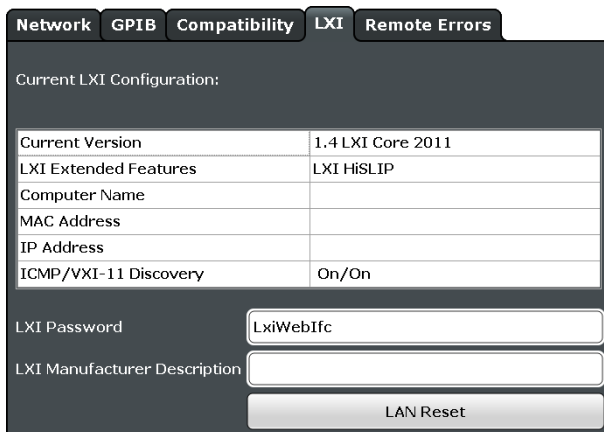

[Current LXI Configuration](#)..... 394

[LXI Password](#)..... 394

[LXI Manufacturer Description](#)..... 394

[LAN Reset](#)..... 395

**Current LXI Configuration**

Displays the current LXI information from the R&S ESW (read-only).

- "Current version"      Current LXI version
- "LXI Extended Features"      Detected LXI features, such as HiSlip (see "[HiSLIP Protocol](#)" on page 347)
- "Computer name"      Name of the R&S ESW as defined in the operating system (see also "[Computer Name](#)" on page 387)
- "MAC address"      Media Access Control address (MAC address), a unique identifier for the network card in the R&S ESW
- "IP address"      IP address of the R&S ESW as defined in the operating system (see also "[IP Address](#)" on page 388).
- "ICMP"      Indicates whether the ping responder is active or not
- "VXI-11 Discovery"      If enabled, connected devices are detected automatically using the VXI-11 protocol (see "[VXI-11 Protocol](#)" on page 347)

Remote command:  
[SYSTem:LXI:INFO?](#) on page 653

**LXI Password**

Password for LAN configuration. The default password is *LxiWebIfc*.

Remote command:  
[SYSTem:LXI:PASSword](#) on page 654

**LXI Manufacturer Description**

Instrument description of the R&S ESW

Remote command:  
[SYSTem:LXI:MDEscription](#) on page 654

### LAN Reset

Resets the LAN configuration to its default settings (LCI function).

According to the LXI standard, an LCI must set the following parameters to a default state.

Parameter	Value
TCP/IP Mode	DHCP + Auto IP Address
Dynamic DNS	Enabled
ICMP Ping	Enabled
Password for LAN configuration	LxiWebIfc

The LAN settings are configured in the "Network" tab of the "Network + Remote" dialog box or using the instrument's LXI Browser interface.

Remote command:

[SYSTem:LXI:LANReset](#) on page 654

## 12.4.5 Remote Errors

**Access:** [SETUP] > "Network + Remote" > "Remote Errors " tab

The error messages generated by the R&S ESW during remote operation are displayed here.

The messages are displayed in the order of their occurrence; the most recent messages are placed at the top of the list.

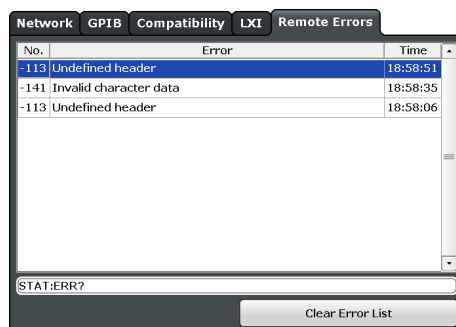

The most recent error message during remote operation can be displayed on the screen, see ["Display Remote Errors"](#) on page 390.

If the number of error messages exceeds the capacity of the error buffer, the oldest error message is removed before the newest one is inserted. To clear the message buffer use the "Clear Error List" button. It is automatically cleared when the R&S ESW is shut down.

The following information is available:

No	Device-specific error code
Error	Brief description of the error
Date/Time	Time the message occurred

**Remote command:**

`SYSTem:ERRor:LIST?` on page 659

**Clear Error List**

Deletes the error message buffer for remote operation.

**Note:** The remote error list is automatically cleared when the R&S ESW is shut down.

Remote command:

`SYSTem:ERRor:CLEar:REMote` on page 651

## 12.4.6 Returning to Manual Mode ("Local")

When switched on, the instrument is always in the manual measurement mode and can be operated via the front panel. As soon as the instrument receives a remote command, it is switched to the remote control mode.

In remote control mode, all keys of the instrument except the [PRESET] key are disabled. The "LOCAL" softkey and the [Remote Display Update](#) softkey are displayed.

**Local**

The instrument switches from remote to manual operation, but only if the local lockout function has not been activated in the remote control mode (see "[GPIB Interface Messages](#)" on page 350).

Furthermore, when you return to manual operation, the following happens:

- All front panel keys are enabled.
- The main softkey menu of the current mode is displayed.
- The measurement diagrams, traces and display fields are displayed again.
- If, at the time of pressing the "LOCAL" softkey, the synchronization mechanism via \*OPC, \*OPC? or \*WAI is active, the currently running measurement procedure is aborted and synchronization is achieved by setting the corresponding bits in the registers of the status reporting system.
- Bit 6 (User Request) of the Event Status Register is set.  
If the status reporting system is configured accordingly, this bit immediately causes the generation of a service request (SRQ) to inform the control software that the user wishes to return to front panel control. For example, this can be used to interrupt the control program and to correct instrument settings manually. This bit is set each time the "LOCAL" softkey is pressed.

**Note:** Before you switch back to manual operation, all remote command processing must be completed. Otherwise, the instrument will switch back to remote control immediately.

If you select the "Local" softkey while a self-alignment or a self-test is still running (which was started remotely), the instrument only returns to the manual operation state when the alignment or test is completed.

Remote command:

[SYSTem:KLOCK](#) on page 653

## 12.5 How to Set Up a Network and Remote Control

### NOTICE

#### Risk of network failure

Consult your network administrator before performing the following tasks:

- Connecting the instrument to the network
- Configuring the network
- Changing IP addresses
- Exchanging hardware

Errors can affect the entire network.

#### Remote operation

You can operate the instrument remotely from a connected computer using SCPI commands (see [Chapter 12.1.2, "SCPI \(Standard Commands for Programmable Instruments\)"](#), on page 353). Before you send remote commands you must configure the instrument in a LAN network or connect it to a PC via the GPIB interface as described in [Chapter 12.5.1, "How to Configure a Network"](#), on page 397.

#### Remote Desktop

In production test and measurement, a common requirement is central monitoring of the T&M instruments for remote maintenance and remote diagnostics. Equipped with the Remote Desktop software of Windows, the R&S ESW ideally meets requirements for use in production. The computer that is used for remote operation is called "controller" here.

The following tasks can be performed using Remote Desktop:

- Access to the control functions via a virtual front panel (soft front panel)
- Printout of measurement results directly from the controller
- Storage of measured data on the controller's hard disk

This documentation provides basic instructions on setting up the Remote Desktop for the R&S ESW. For details refer to the Microsoft Windows operating system documentation.

### 12.5.1 How to Configure a Network

A precondition for operating or monitoring the instrument remotely is that it is connected to a LAN network or a PC connected to the GPIB interface. This is described here.



### Windows Firewall Settings

A firewall protects an instrument by preventing unauthorized users from gaining access to it through a network. Rohde & Schwarz highly recommends the use of the firewall on your instrument. R&S instruments are shipped with the Windows firewall enabled and preconfigured in such a way that all ports and connections for remote control are enabled. For more details on firewall configuration see the Microsoft Windows help system and the R&S White Paper (available from the Rohde & Schwarz website):

[1DC01: Malware Protection II White Paper Windows 7](#)

#### 12.5.1.1 How to Connect the Instrument to the Network

There are two methods to establish a LAN connection to the instrument:

- A non-dedicated network (Ethernet) connection from the instrument to an existing network made with an ordinary RJ-45 network cable. The instrument is assigned an IP address and can coexist with a computer and with other hosts on the same network.
- A dedicated network connection (Point-to-point connection) between the instrument and a single computer made with a (crossover) RJ-45 network cable. The computer must be equipped with a network adapter and is directly connected to the instrument. The use of hubs, switches, or gateways is not required, however, data transfer is still performed using the TCP/IP protocol. An IP address has to be assigned to the instrument and the computer, see [Chapter 12.5.1.2, "How to Assign the IP Address"](#), on page 398.

**Note:** As the R&S ESW uses a 1 GBit LAN, a crossover cable is not necessary (due to Auto-MDI(X) functionality).

- ▶ To establish a non-dedicated network connection, connect a commercial RJ-45 cable to one of the LAN ports.  
To establish a dedicated connection, connect a (crossover) RJ-45 cable between the instrument and a single PC.

If the instrument is connected to the LAN, Windows automatically detects the network connection and activates the required drivers.

The network card can be operated with a 1 GBit Ethernet IEEE 802.3u interface.

#### 12.5.1.2 How to Assign the IP Address

Depending on the network capacities, the TCP/IP address information for the instrument can be obtained in different ways.

- If the network supports dynamic TCP/IP configuration using the Dynamic Host Configuration Protocol (DHCP), all address information can be assigned automatically.
- If the network does not support DHCP, or if the instrument is set to use alternate TCP/IP configuration, the addresses must be set manually.

By default, the instrument is configured to use dynamic TCP/IP configuration and obtain all address information automatically. This means that it is safe to establish a physical connection to the LAN without any previous instrument configuration.



When a DHCP server is used, a new IP address may be assigned each time the PC is restarted. This address must first be determined on the PC itself. Thus, when using a DHCP server, it is recommended that you use the permanent computer name, which determines the address via the DNS server (see ["Using a DNS server to determine the IP address"](#) on page 400).

### NOTICE

#### Risk of network errors

Connection errors can affect the entire network. If your network does not support DHCP, or if you choose to disable dynamic TCP/IP configuration, you must assign valid address information before connecting the instrument to the LAN. Contact your network administrator to obtain a valid IP address.

#### Assigning the IP address on the instrument

1. Press the [SETUP] key.
2. Press the "Network + Remote" softkey.
3. Select the "Network" tab.
4. In the "Network + Remote" dialog, toggle the "DHCP On/Off" setting to the required mode.  
If DHCP is "Off", you must enter the IP address manually, as described in the following steps.  
**Note:** When DHCP is changed from "On" to "Off", the previously set IP address and subnet mask are retrieved.  
If DHCP is "On", the IP address of the DHCP server is obtained automatically. The configuration is saved, and you are prompted to restart the instrument. You can skip the remaining steps.  
**Note:** When a DHCP server is used, a new IP address may be assigned each time the instrument is restarted. This address must first be determined on the instrument itself. Thus, when using a DHCP server, it is recommended that you use the permanent computer name, which determines the address via the DNS server (See ["Using a DNS server to determine the IP address"](#) on page 35 and [Chapter 2.5.3, "Using Computer Names"](#), on page 36).
5. Enter the "IP Address", for example *192.0.2.0*. The IP address consists of four number blocks separated by dots. Every block contains a maximum of 3 numbers.
6. Enter the "Subnet Mask", for example *255.255.255.0*. The subnet mask consists of four number blocks separated by dots. Every block contains a maximum of 3 numbers.

7. Close the dialog box.  
If you have entered an invalid IP address or subnet mask, the message "out of range" is displayed in the status line. If the settings are correct, the configuration is saved, and you are prompted to restart the instrument.
8. Confirm the displayed message ("Yes" button) to restart the instrument.

### Using a DNS server to determine the IP address

If a DNS server is configured on the R&S ESW, the server can determine the current IP address for the connection using the permanent computer name.

1. Obtain the name of your DNS domain and the IP addresses of the DNS and WINS servers on your network (see [Chapter 12.5.1.3, "How to Change the Instrument Name"](#), on page 401).
2. Press the [Setup] key and then the "Network + Remote" softkey.
3. In the "Network" tab, select the "Open Dialog 'Network Connections'" button.
4. Double-tap the "Local Area Network" entry.
5. In the "Local Area Connection Status" dialog box, select the "Properties" button.  
The items used by the LAN connection are displayed.
6. Tap the entry named "Internet Protocol Version 4 (TCP/IPv4)" to highlight it.

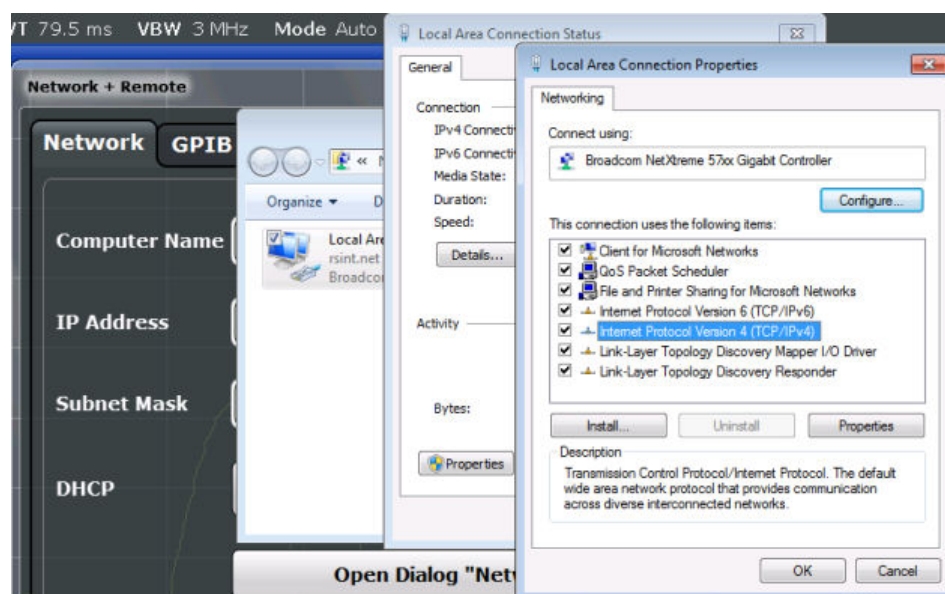

7. Select the "Properties" button.
8. On the "General" tab, select "Use the following DNS server addresses" and enter your own DNS addresses.

For more information refer to the Microsoft Windows operating system Help.

### 12.5.1.3 How to Change the Instrument Name

In a LAN that uses a DNS server (Domain Name System server), each PC or instrument connected in the LAN can be accessed via an unambiguous computer name instead of the IP address. The DNS server translates the host name to the IP address. This is especially useful when a DHCP server is used, as a new IP address may be assigned each time the instrument is restarted.

Each instrument is delivered with an assigned computer name, but this name can be changed.

#### To change the instrument's computer name

1. Press the [Setup] key and then the "Network + Remote" softkey.  
The current "Computer Name" is displayed in the "Network" tab.
2. Enter the new computer name and close the dialog box.  
The configuration is saved, and you are prompted to restart the instrument.
3. Confirm the displayed message ("Yes" button) to restart the instrument.

### 12.5.1.4 How to Configure the LAN Using the LXI Web Browser Interface

The instrument's LXI browser interface works correctly with all W3C compliant browsers.

- In the web browser, open the `http://<instrument-hostname>` or `http://<instrument-ip-address>` page, e.g. `http://10.113.10.203`.

The default password to change LAN configurations is *LxiWebIfc*.

The "Instrument Home Page" (welcome page) opens.

The screenshot displays the LXI Web Browser Interface for an R&S ESW instrument. The interface is divided into a left sidebar and a main content area. The sidebar contains navigation links for Home, Lan Configuration, Status, Utilities, Instrument Control (Web Control, File Download, File Upload), License Manager (Manage Licenses), and Help (Glossary, www.rohde-schwarz.com). The main content area is titled "Instrument Properties" and displays the following information:

Instrument Model	ESW-26 EMI Test Receiver
Manufacturer	Rohde & Schwarz GmbH & Co. KG
Serial Number	[REDACTED]
Description	R&S ESW-1
LXI Version	1.4 LXI Core 2011
LXI Extended Features	LXI HISLIP
DNS Host Name(s)	[REDACTED]
MAC Address	[REDACTED]
IP Address	[REDACTED]
Firmware Revision	1.00a
Current Time	Tuesday, 2015/09/15, 14:14:24
Current Time source	Operating System
VISA resource string	[REDACTED]
Device Indicator	INACTIVE (press to toggle)

At the bottom of the main content area, there is a "Status" section showing "No error". A copyright notice "© 2015 ROHDE&SCHWARZ. All rights reserved." is visible in the bottom right corner.



The instrument home page displays the device information required by the LXI standard including the VISA resource string in read-only format.



- ▶ Press the "Device Indicator" button on the "Instrument Home Page" to activate or deactivate the LXI status icon on the status bar of the R&S ESW. A green LXI status symbol indicates that a LAN connection has been established; a red symbol indicates an error, for example, that no LAN cable is connected. When a device is connecting to the instrument, the LXI logo blinks. The "Device Indicator" setting is not password-protected.

The most important control elements in the navigation pane of the browser interface are the following:

- "LAN Configuration" opens the menu with configuration pages.
- "Status" displays information about the LXI status of the instrument.
- "Help > Glossary" opens a document with a glossary of terms related to the LXI standard.

### LAN Configuration

The LAN configuration consists of three parts:

- "IP configuration" provides all mandatory LAN parameters.
- "Advanced LAN Configuration" provides LAN settings that are not declared mandatory by the LXI standard.
- "Ping Client" provides the ping utility to verify the connection between the instrument and other devices.

### IP Configuration

The "LAN Configuration > IP configuration" web page displays all mandatory LAN parameters and allows their modification.

For the manual configuration mode, the static IP address, subnet mask, and default gateway are used to configure the LAN. The automatic configuration mode uses DHCP server or Dynamic Link Local Addressing (Automatic IP) to obtain the instrument IP address.



Changing the LAN configuration is password-protected. The default password is *Lxi-WebIfc* (notice upper and lower case characters).

You can change the LXI password in the "Network + Remote" dialog box, see [Chapter 12.4.4, "LXI Settings"](#), on page 393

### Advanced LAN Configuration

The "LAN Configuration > Advanced LAN Configuration" parameters are used as follows:

- The "Negotiation" configuration field provides different Ethernet speed and duplex mode settings. In general, the "Auto Detect" mode is sufficient.
- "ICMP Ping" must be enabled to use the ping utility.

- "VXI-11" is the protocol that is used to detect the instrument in the LAN. According to the standard, LXI devices must use VXI-11 to provide a detection mechanism; other additional detection mechanisms are permitted.
- mDNS and DNS-SD are two additional protocols: Multicast DNS and DNS Service Discovery. They are used for device communication in zero configuration networks working without DNS and DHCP

### Ping Client

Ping is a utility that verifies the connection between the LXI-compliant instrument and another device. The ping command uses the `ICMP` echo request and echo reply packets to determine whether the LAN connection is functional. Ping is useful for diagnosing IP network or router failures. The ping utility is not password-protected.

To initiate a ping between the LXI-compliant instrument and a second connected device:

1. Enable "ICMP Ping" on the "Advanced LAN Configuration" page (enabled after an LCI).
2. Enter the IP address of the second device **without the ping command and without any further parameters** into the "Destination Address" field (e.g. `10.113.10.203`).
3. Select "Submit".

#### 12.5.1.5 How to Change the GPIB Instrument Address

In order to operate the instrument via remote control, it must be addressed using the GPIB address. The remote control address is factory-set to 20, but it can be changed if it does not fit in the network environment. For remote control, addresses 0 through 30 are allowed. The GPIB address is maintained after a reset of the instrument settings.

#### Setting the GPIB address

1. On the R&S ESW, press the [SETUP] key.
2. Press the "Network + Remote" softkey.
3. In the "Network + Remote" dialog box, select the "GPIB" tab.
4. In the "GPIB Address" field, enter a value between 0 and 30.

#### Remote command:

```
SYST:COMM:GPIB:ADDR 18
```

### 12.5.2 How to Operate the Instrument Without a Network

To operate the instrument without a network connection either temporarily or permanently, no special measures are necessary. Microsoft Windows automatically detects

the interruption of the network connection and does not set up the connection when the instrument is switched on.

If you are not prompted to enter the user name and password, proceed as described in [Chapter 12.5.3.3, "How to Activate or Deactivate the Automatic Login Mechanism"](#), on page 405.

### 12.5.3 How to Log on to the Network

Microsoft Windows requires that users identify themselves by entering a user name and password in a login window. You can set up two types of user accounts, either an administrator account with unrestricted access to the computer/domain or a standard user account with limited access. The instrument provides an auto-login function for the administrator account, i.e. login with unrestricted access is carried out automatically in the background. By default, the user name for the administrator account is "Instrument", and the user name for the standard user account is "NormalUser". In both cases the initial password is "894129". You can change the password in Microsoft Windows for any user at any time. Some administrative tasks require administrator rights (e.g. firmware updates or the configuration of a LAN network).

Refer to [Chapter 11, "General Instrument Setup"](#), on page 289 to find out which functions are affected.

At the same time you log on to the operating system, you are automatically logged on to the network. As a prerequisite, the user name and the password must be identical on the instrument and on the network.

#### 12.5.3.1 How to Create Users

After the software for the network has been installed, the instrument issues an error message the next time it is switched on because there is no user named "instrument" (= default user ID for Windows automatic login) in the network. Thus, a matching user must be created in the R&S ESW and in the network, the password must be adapted to the network password, and the automatic login mechanism must then be deactivated.

The network administrator is responsible for creating new users in the network. A new user can be created on the instrument using the "User Account" dialog box:

1.  Select the "Windows" icon in the toolbar to access the operating system.
2. In the "Start" menu, select "Control Panel" and then select "User Accounts."
3. Select "Give other users access to this computer" and then "Add".  
The "Add New User" dialog box is displayed.
4. Enter the name of the new user in the text field and select "Next".
5. Define the level of access you want to allow the new user:

- Select "Standard" to create an account with limited rights.
- Select "Administrator" to create an account with administrator rights.

**Note:** Full firmware functionality requires administrator rights.

6. Select the "Finish" button.  
The new user is created.

### 12.5.3.2 How to Change the User Password

After the new user has been created on the instrument, the password must be adapted to the network password. This is also done using the "User Accounts" dialog box.

1. 

Select the "Windows" icon in the toolbar to access the operating system.

2. Press [Ctrl + Alt + Delete], then select "Change a password".
3. Enter the user account name.
4. Enter the old password.
5. Enter the new password in the upper text line and repeat it in the following line.
6. Press [Enter].  
The new password is now active.

### 12.5.3.3 How to Activate or Deactivate the Automatic Login Mechanism

#### Deactivating the automatic login mechanism

When shipped, the instrument is already configured to automatically log on under Microsoft Windows. To deactivate the automatic login mechanism, perform the following steps:

1. In the "Start" menu, select "Run".  
The "Run" dialog box is displayed.
2. Enter the command `C:\R_S\Instr\User\NO_AUTOLOGIN.REG`.
3. Press the [ENTER] key to confirm.  
The automatic login mechanism is deactivated. The next time you switch on the instrument, you are prompted to enter your user name and password before the firmware is started.

#### Reactivating the automatic login mechanism

1. In the "Start" menu, select "Run".  
The "Run" dialog box is displayed.
2. Enter the command `C:\R_S\Instr\User\AUTOLOGIN.REG`.

3. Press the [ENTER] key to confirm.  
The automatic login mechanism is reactivated. It will be applied the next time the instrument is switched on.

#### 12.5.4 How to Share Directories (only with Microsoft Networks)

Sharing directories makes data available for other users. This is only possible in Microsoft networks. Sharing is a property of a file or directory.

1. In the "Start" menu, select "Programs", "Accessories" and then select "Windows Explorer".
2. Select the desired folder with the right mouse button.
3. In the context menu, select "Sharing with > Specific people".  
The dialog box for sharing a directory is displayed.
4. Select a user from the list or add a new name and select the "Add" button.
5. Select the "Share" button.
6. Select "Done" to close the dialog box.  
The drive is shared and can be accessed by the selected users.

#### 12.5.5 How to Control the R&S ESW via the Web Browser Interface

Via the LXI browser interface to the R&S ESW one or more users can control the instrument remotely from another PC without additional installation. Most instrument controls are available via the front panel simulation. File upload and download between the instrument and the remote PC is also available.

##### To access the R&S ESW via the web browser interface

1. Start a web browser that supports html5 (W3C compliant).
2. Enter the IP address of the R&S ESW in the browser's address bar.  
The R&S ESW's Welcome page is displayed.
3. In the navigation pane, select "Instrument Control > Web Control".  
The instrument's display is shown in a new browser window, with a software front panel displayed beside or below it.
4. Use the mouse cursor to access the functionality in the software front panel or in the display as you would directly on the instrument's front panel.

### To exchange files with the R&S ESW

You can download files, for example stored measurement data, from the R&S ESW to the remote PC, or upload files, for example limit line definitions, from the PC to the R&S ESW.

1. In the web browser, select the Welcome page window.
2. In the navigation pane, select "Instrument Control" > "File Upload" or "File Download".

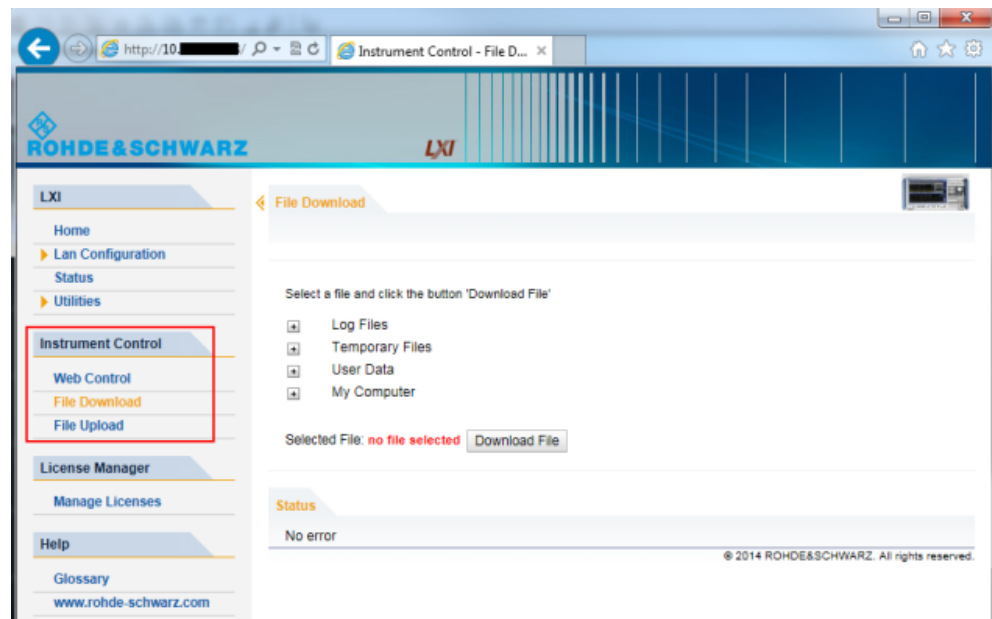

The most commonly used folders on the instrument are displayed, for example those that contain user data, as well as the top-most *My Computer* folder, from which you can access all other folders on the instrument.

3. To download a file from the R&S ESW, select the file from the displayed folders and then select "Download File".
4. To upload a file to the R&S ESW:
  - a) From the displayed folders in the web browser window, select the folder on the R&S ESW to which you want to copy a file.
  - b) Under "File to Upload", select "Browse" to open a file selection dialog box and select the required file on the PC.
  - c) Select "Upload" to copy the file from the PC to the defined folder on the R&S ESW.

### 12.5.6 How to Deactivate the Web Browser Interface

If you want to prevent other users in the LAN from accessing or operating the R&S ESW via its LXI web browser interface, you must deactivate this function. Note

that **after a firmware update** the function is **automatically active** again until you deactivate it manually.

### To deactivate the LXI web browser interface

1. 

Select the "Windows" icon in the toolbar to access the operating system.
2. In the "Start" menu, select "Control Panel".
3. Select "System and Security" > "Administrative Tools".
4. From the list on the right, select "Services".
5. From the list of local services, select "R&S TightVNC Server".

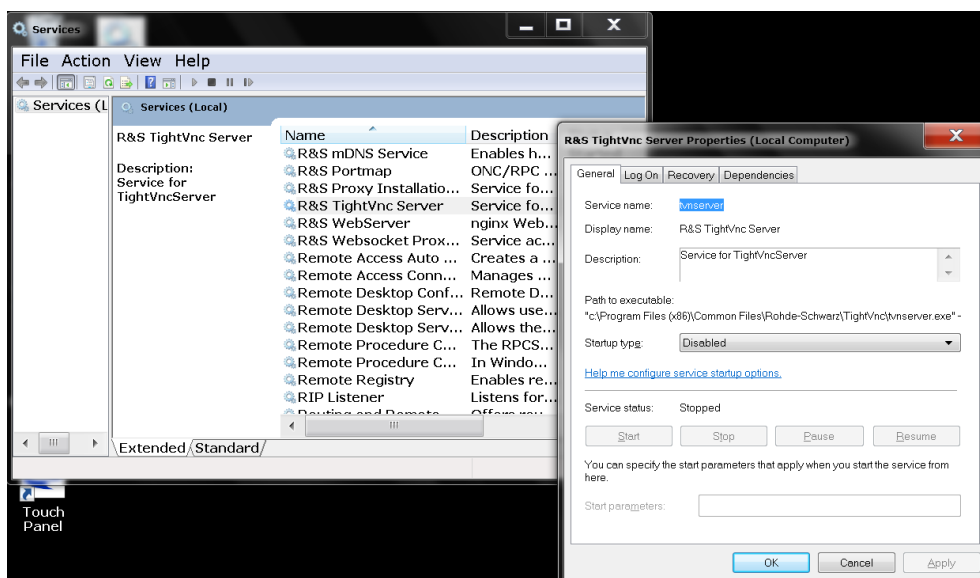

6. Set "Startup type" to "Disabled".
7. Select "Stop".
8. Select "Apply".

The next time a user enters the IP address of the instrument in a web browser, an error message is displayed:

```
Failed to connect to server (code. 1006)
```

## 12.5.7 How to Set Up Remote Desktop

Remote Desktop is a Windows application which can be used to access and control the instrument from a remote computer through a LAN connection. While the instrument is in operation, the instrument screen contents are displayed on the remote computer, and Remote Desktop provides access to all of the applications, files, and network resources of the instrument. Thus, remote operation of the R&S ESW is possible.

With Microsoft Windows, Remote Desktop Client is part of the operating system. For other versions of Windows, Microsoft offers the Remote Desktop Client as an add-on. For details refer to the Microsoft Windows operating system documentation.

### 12.5.7.1 How to Configure the R&S ESW for Remote Operation via Remote Desktop

1. Create a fixed IP address for the TCP/IP protocol as described in [Chapter 12.5.1.2, "How to Assign the IP Address"](#), on page 398.

**Note:** To avoid problems, use a fixed IP address.

When a DHCP server is used, a new IP address is assigned each time the instrument is restarted. This address must first be determined on the instrument itself. Thus, using a DHCP server is not suitable for remote operation of the R&S ESW via Remote Desktop.

2. 

Select the "Windows" icon in the toolbar to access the operating system.

3. In the "Start" menu, select the "Control Panel" and then "System and Security".
4. In the "System" area, select "Allow remote access".

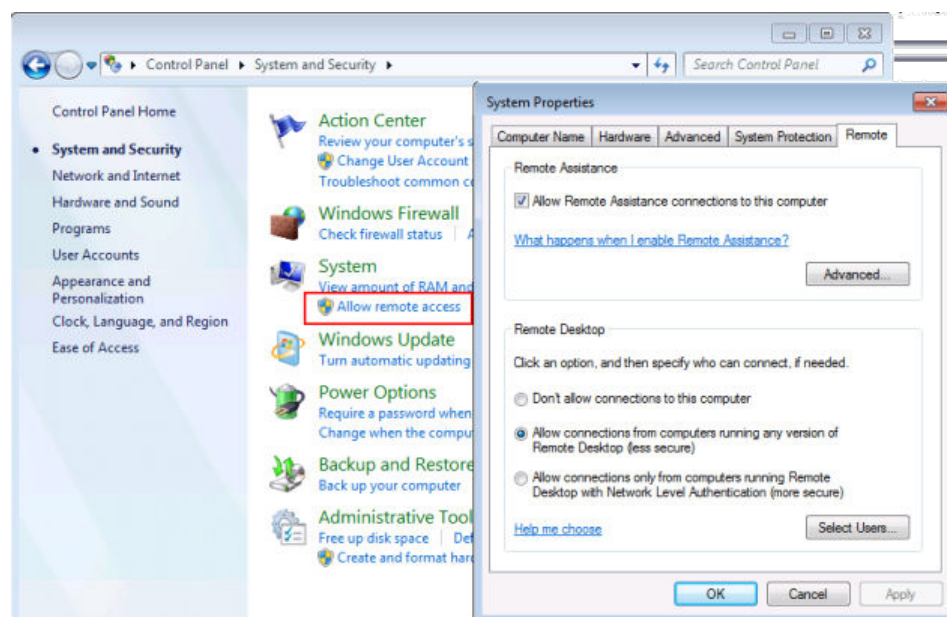

5. Define which users are to be given access to the R&S ESW via Remote Desktop.
 

**Note:** The user account under which configuration is carried out is automatically enabled for Remote Desktop.

  - a) In the "Remote" tab, in the "Remote Desktop" area, select the "Select Users" button.
  - b) Select the users or create new user accounts as described in [Chapter 12.5.3.1, "How to Create Users"](#), on page 404.



- c) Select "OK" to confirm the settings.
6. The R&S ESW is now ready for connection setup with the Remote Desktop program of the controller.

### 12.5.7.2 How to Configure the Controller



#### Remote Desktop Client

With Microsoft Windows, Remote Desktop Client is part of the operating system and can be accessed via "Start > Programs > Accessories > Remote Desktop Connection". For other versions of Windows, Microsoft offers the Remote Desktop Client as an add-on.

1. In the "Start" menu of the controller, select "All Programs > Accessories > Remote Desktop Connection".  
The "Remote Desktop Connection" dialog box is displayed.
2. Select the "Options >>" button.  
The dialog box is expanded to display the configuration data.

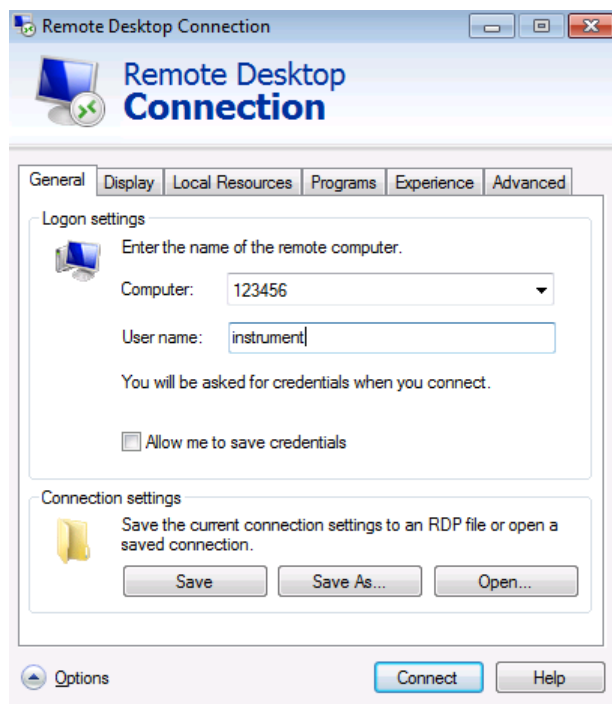

3. Open the "Experience" tab.  
The settings on this tab are used to select and optimize the connection speed.
4. In the list, select the appropriate connection (for example: LAN (10 Mbps or higher)).  
Depending on your selection (and how powerful the connection is), the options are activated or deactivated.

5. To improve the performance, you can deactivate the "Desktop background", "Show window contents while dragging" and "Menu and window animation" options.
6. Open the "Local Resources" tab to enable printers, local drives and serial interfaces.
7. If you will need to access drives of the controller from the R&S ESW (e.g. in order to store settings or to copy files from the controller to the R&S ESW), activate the "Disk drives" option.  
Windows will then map drives of the controller to the corresponding network drives.
8. To use printers connected to the controller while accessing them from the R&S ESW, activate the "Printers" options. Do not change the remaining settings.
9. Open the "Display" tab.  
The options to configure the R&S ESW screen display are displayed.
10. Under "Remote desktop size", you can set the size of the R&S ESW window on the desktop of the controller.
11. Under "Colors", do not change the settings.
12. Set the "Display the connection bar when I use the full screen" option:  
If activated, a bar showing the network address of the R&S ESW will appear at the top edge of the screen. You can use this bar to reduce, minimize or close the window.  
If deactivated, the only way you can return to the controller desktop from the R&S ESW screen in full screen mode is to select "Disconnect" from the "Start" menu.

### 12.5.7.3 How to Start and Close the Remote Desktop

#### To set up a connection to the R&S ESW

1. In the "Remote Desktop Connection" dialog box (see [Chapter 12.5.7.2, "How to Configure the Controller"](#), on page 410), open the "General" tab.
2. In the "Computer" field, enter the IP address of the R&S ESW.  
In the "User name" field, enter *instrument* to log in as an administrator, or *Normal User* to log in as a standard user.  
In the "Password" field, enter *894129*.
3. To save the connection configuration for later use:
  - a) Select the "Save As" button.  
The "Save As" dialog box is displayed.
  - b) Enter the name for the connection information (\* .RDP).
4. To load an existing connection configuration:
  - a) Select the "Open" button.  
The "Open" dialog box is displayed.

- b) Select the \*.RDP file.
5. Select the "Connect" button.  
The connection is set up.
6. If the "Disk drives" option is activated on the "Local Resources" tab, a warning is displayed indicating that the drives are enabled for access from the R&S ESW. Select "OK" to confirm the warning.
7. After a few moments, the R&S ESW screen is displayed.  
If a dark screen appears or a dark square appears in the upper left-hand corner of the screen, you must restart the R&S ESW in order to see the modified screen resolution.

 <p>Analyzer</p>	<ul style="list-style-type: none"><li>• Press the key combination [ALT] + [F4].</li><li>• The R&amp;S ESW firmware is shut down, which may take a few seconds.</li><li>• On the desktop, double-tap the "Analyzer" icon.</li></ul>
---	--

The firmware restarts and then automatically opens the "Soft Front Panel", i.e. the user interface on which all front panel controls and the rotary knob are mapped to buttons.

For more information see [Chapter 11.2.4, "How to Work with the Soft Front Panels"](#), on page 304.

8. To deactivate or activate the "Softfrontpanel", press the [F6] key.  
After the connection is established, the R&S ESW screen is displayed in the "Remote Desktop" application window.



The Windows "Start" menu can be made available by expanding the "Remote Desktop" window to full size.

During the connection with the controller, the login entry is displayed on the R&S ESW screen.

### To terminate Remote Desktop control

The connection can be terminated by the controller or by a user at the R&S ESW:

1. On the controller, close the "Remote Desktop" window at any time.  
The connection to the R&S ESW is terminated.
2. On the R&S ESW, a user logs on.  
The connection to the controller is terminated as a result. A message is displayed on the controller display indicating that another user has assumed control of the instrument.

### Restoring the connection to the R&S ESW

Follow the instructions above for setting up a connection to the R&S ESW. If the connection is terminated and then restored, the R&S ESW remains in the same state.

#### 12.5.7.4 How to Shut Down the R&S ESW via Remote Operation

1. Select the R&S ESW softfrontpanel and close the application with the key combination [ALT] + [F4].

2. Select the desktop and press the key combination [ALT] + [F4].  
A safety query is displayed to warn you that the instrument cannot be reactivated via remote operation and asks you whether you want to continue the shutdown process.
3. Respond to the safety query with "Yes".  
The connection with the controller is terminated and the R&S ESW is shut down.

### 12.5.8 How to Start a Remote Control Session from a PC

When you switch on the R&S ESW, it is always in manual operation state ("local" state) and can be operated via the front panel.

#### To start remote control

1. Send an addressed command (`GTR` - Go to Remote) from a controller to the instrument.  
The instrument is switched to remote control ("remote" state). Operation via the front panel is disabled. Only the "Local" softkey is displayed to return to manual operation. The instrument remains in the remote state until it is reset to the manual state via the instrument or via remote control interfaces. Switching from manual operation to remote control and vice versa does not affect the other instrument settings.
2. During program execution, send the `SYSTem:DISPlay:UPDate ON` command to activate the display of results (see `SYSTem:DISPlay:UPDate` on page 651).  
The changes in the device settings and the recorded measurement values are displayed on the instrument screen.
3. To obtain optimum performance during remote control, send the `SYSTem:DISPlay:UPDate OFF` command to hide the display of results and diagrams again (default setting in remote control).
4. To prevent unintentional return to manual operation, disable the keys of the instrument using the universal command `LLO`.  
Switching to manual mode is only possible via remote control then. This function is only available for the GPIB interface.
5. To enable the keys of the R&S ESW again, switch the instrument to local mode (`GTL` - Go to Local), i.e. deactivate the `REN` line of the remote control interface.



If the instrument is operated exclusively in remote control, it is recommended that you switch off the display. For details see "[Remote Display Update](#)" on page 389.

---

## 12.5.9 How to Return to Manual Operation

Before you switch back to manual operation, all remote command processing must be completed. Otherwise, the instrument will switch back to remote control immediately.

- ▶ Select the "Local" softkey, or use the following GPIB command:

```
status = viGpibControlREN(vi, VI_GPIB_REN_ADDRESS_GTL)
```



If you select the "Local" softkey while a self-alignment or a self-test is still running (which was started remotely), the instrument only returns to the manual operation state when the alignment or test is completed.

---

# 13 Remote Commands in the Receiver Application

• Conventions Used in SCPI Command Descriptions.....	416
• Common Suffixes.....	417
• Common Commands.....	417
• Application Selection.....	422
• Measurements and Result Displays.....	426
• Configuration.....	473
• Analysis.....	504
• Data Management.....	567
• General Instrument Setup.....	610
• Using the Status Register.....	664
• Service Request.....	669
• Reference: GPIB Commands of Emulated HP Models.....	676
• Reference: Command Set of Emulated PSA Models.....	704
• Reference: Command Set of Emulated PXA Models.....	708

## 13.1 Conventions Used in SCPI Command Descriptions

Note the following conventions used in the remote command descriptions:

- **Command usage**  
If not specified otherwise, commands can be used both for setting and for querying parameters.  
If a command can be used for setting or querying only, or if it initiates an event, the usage is stated explicitly.
- **Parameter usage**  
If not specified otherwise, a parameter can be used to set a value and it is the result of a query.  
Parameters required only for setting are indicated as **Setting parameters**.  
Parameters required only to refine a query are indicated as **Query parameters**.  
Parameters that are only returned as the result of a query are indicated as **Return values**.
- **Conformity**  
Commands that are taken from the SCPI standard are indicated as **SCPI confirmed**. All commands used by the R&S ESW follow the SCPI syntax rules.
- **Asynchronous commands**  
A command which does not automatically finish executing before the next command starts executing (overlapping command) is indicated as an **Asynchronous command**.
- **Reset values (\*RST)**  
Default parameter values that are used directly after resetting the instrument (\*RST command) are indicated as **\*RST** values, if available.
- **Default unit**

This is the unit used for numeric values if no other unit is provided with the parameter.

- **Manual operation**

If the result of a remote command can also be achieved in manual operation, a link to the description is inserted.

## 13.2 Common Suffixes

In the Receiver application, the following common suffixes are used in remote commands:

*Table 13-1: Common suffixes used in remote commands in the Receiver application*

Suffix	Value range	Description
<m>	1..16	Marker
<n>	1..16	Window (in the currently selected channel)
<t>	1..6	Trace
<li>	1 to 8	Limit line
<i>	1..3	Selects one of the analog output channels (1, 2 or Phones).
<k>	1..8 (Limit line) 1   2 (Display line)	Selects a limit or display line.
<peak>	1..3000	Selects a peak.



### Selecting windows in multiple channels

Note that the suffix <n> always refers to a window in the currently selected channel.

## 13.3 Common Commands

Common commands are described in the IEEE 488.2 (IEC 625-2) standard. These commands have the same effect and are employed in the same way on different devices. The headers of these commands consist of "\*" followed by three letters. Many common commands are related to the Status Reporting System.

Available common commands:

*CAL?	418
*CLS	418
*ESE	418
*ESR?	418
*IDN?	419
*IST?	419
*OPC	419
*OPT?	419



*PCB.....	419
*PRE.....	420
*PSC.....	420
*RST.....	420
*SRE.....	420
*STB?.....	421
*TRG.....	421
*TST?.....	421
*WAI.....	421

---

### \*CAL?

Calibration query

Initiates a calibration of the instrument and subsequently queries the calibration status. Responses > 0 indicate errors.

**Note:** If you start a self-alignment remotely, then select the "Local" softkey while the alignment is still running, the instrument only returns to the manual operation state after the alignment is completed.

**Usage:** Query only

**Manual operation:** See " [Start Self Alignment](#) " on page 292

---

### \*CLS

Clear status

Sets the status byte (STB), the standard event register (ESR) and the `EVENT` part of the `QUESTIONABLE` and the `OPERATION` registers to zero. The command does not alter the mask and transition parts of the registers. It clears the output buffer.

**Usage:** Setting only

---

### \*ESE <Value>

Event status enable

Sets the event status enable register to the specified value. The query returns the contents of the event status enable register in decimal form.

**Parameters:**

<Value> Range: 0 to 255

---

### \*ESR?

Event status read

Returns the contents of the event status register in decimal form and subsequently sets the register to zero.

**Return values:**

<Contents>                    Range:     0 to 255

**Usage:**                      Query only

---

**\*IDN?**

Identification

Returns the instrument identification.

**Example:**                    Rohde&Schwarz,ESW-26,1328.4100K26/100005,1.00

**Usage:**                      Query only

**Manual operation:**    See "[\\*IDN Format](#)" on page 390

---

**\*IST?**

Individual status query

Returns the contents of the IST flag in decimal form. The IST flag is the status bit which is sent during a parallel poll.

**Return values:**

<ISTflag>                    0 | 1

**Usage:**                      Query only

---

**\*OPC**

Operation complete

Sets bit 0 in the event status register when all preceding commands have been executed. This bit can be used to initiate a service request. The query form writes a "1" into the output buffer as soon as all preceding commands have been executed. This is used for command synchronization.

---

**\*OPT?**

Option identification query

Queries the options included in the instrument. For a list of all available options and their description refer to the data sheet.

**Usage:**                      Query only

---

**\*PCB <Address>**

Pass control back

Indicates the controller address to which remote control is returned after termination of the triggered action.

---

**Setting parameters:**

<Address>            Range:     0 to 30

**Usage:**             Setting only

**\*PRE <Value>**

Parallel poll register enable

Sets parallel poll enable register to the indicated value. The query returns the contents of the parallel poll enable register in decimal form.

**Parameters:**

<Value>              Range:     0 to 255

**\*PSC <Action>**

Power on status clear

Determines whether the contents of the `ENABLE` registers are preserved or reset when the instrument is switched on. Thus a service request can be triggered when the instrument is switched on, if the status registers ESE and SRE are suitably configured. The query reads out the contents of the "power-on-status-clear" flag.

**Parameters:**

<Action>             0 | 1

**0**

The contents of the status registers are preserved.

**1**

Resets the status registers.

**\*RST**

Reset

Sets the instrument to a defined default status. The default settings are indicated in the description of commands.

The command is equivalent to `SYSTEM:PRESet`.

**Usage:**             Setting only

**\*SRE <Contents>**

Service request enable

Sets the service request enable register to the indicated value. This command determines under which conditions a service request is triggered.

**Parameters:**

<Contents> Contents of the service request enable register in decimal form.  
Bit 6 (MSS mask bit) is always 0.  
Range: 0 to 255

---

**\*STB?**

Status byte query

Reads the contents of the status byte in decimal form.

**Usage:** Query only

---

**\*TRG**

Trigger

Triggers all actions waiting for a trigger event. In particular, \*TRG generates a manual trigger signal. This common command complements the commands of the TRIGger subsystem.

\*TRG corresponds to the INITiate:IMMediate command.

**Usage:** Event

---

**\*TST?**

Self-test query

Initiates self-tests of the instrument and returns an error code

**Note:** If you start a self-test remotely, then select the "Local" softkey while the test is still running, the instrument only returns to the manual operation state after the test is completed. In this case, the self-test cannot be aborted.

**Return values:**

<ErrorCode> **integer > 0 (in decimal format)**  
An error occurred.  
(For details see the Service Manual supplied with the instrument).  
**0**  
No errors occurred.

**Usage:** Query only

---

**\*WAI**

Wait to continue

Prevents servicing of the subsequent commands until all preceding commands have been executed and all signals have settled (see also command synchronization and \*OPC).

Usage: Event

## 13.4 Application Selection

CALCulate:STATistics:CAPD[:STATe].....	422
DISPlay:ATAB.....	422
INSTrument:CREate:DUPLicate.....	423
INSTrument:CREate[:NEW].....	423
INSTrument:CREate:REPLace.....	423
INSTrument:DELeTe.....	424
INSTrument:LIST?.....	424
INSTrument:REName.....	425
INSTrument[:SELeCt].....	425

---

### CALCulate:STATistics:CAPD[:STATe] <State>

This command creates a new measurement channel for the CISPR APD measurement.

**Note that this is only possible from within a selected spectrum channel.**

#### Parameters:

<State> ON | OFF  
 OFF returns to the spectrum application.  
 \*RST: OFF

#### Example:

```
INST:CRE SAN, 'Spectrum'
INST 'Spectrum'
Creates and selects the Spectrum channel.
CALC:STAT:CAPD ON
Opens a CISPR APD channel.
```

---

### DISPlay:ATAB <State>

This command switches between the MultiView tab and the most recently displayed channel. If only one channel is active, this command has no effect.

#### Parameters:

<State> ON | OFF | 1 | 0  
**ON | 1**  
 The MultiView tab is displayed.  
**OFF | 0**  
 The most recently displayed channel is displayed.  
 \*RST: 0

**INSTrument:CREate:DUPLicate**

This command duplicates the currently selected channel, i.e creates a new channel of the same type and with the identical measurement settings. The name of the new channel is the same as the copied channel, extended by a consecutive number (e.g. "IQAnalyzer" -> "IQAnalyzer 2").

The channel to be duplicated must be selected first using the `INST:SEL` command.

**Example:** `INST:SEL 'Receiver'`  
`INST:CRE:DUPL`  
 Duplicates the channel named 'Receiver' and creates a new channel named 'Receiver 2'.

**Usage:** Event

**Manual operation:** See "[Duplicate Current Channel](#)" on page 85

**INSTrument:CREate[:NEW] <ChannelType>, <ChannelName>**

This command adds an additional channel.

The number of channels you can configure at the same time depends on available memory.

See also

- [INSTrument\[:SElect\]](#) on page 425
- [INSTrument:CREate:DUPLicate](#) on page 423

**Parameters:**

<ChannelType> Channel type of the new channel.  
 For a list of available channel types see [INSTrument:LIST?](#) on page 424.

<ChannelName> String containing the name of the channel. The channel name is displayed as the tab label for the channel.  
 Note: If the specified name for a new channel already exists, the default name, extended by a sequential number, is used for the new channel (see [INSTrument:LIST?](#) on page 424).  
 Channel names can have a maximum of 31 characters, and must be compatible with the Windows conventions for file names. In particular, they must not contain special characters such as ":", "\*", "?".

**Example:** `INST:CRE REC, 'Receiver 2'`  
 Adds an additional Receiver channel named "Receiver 2".

**Manual operation:** See "[New Channel](#)" on page 85

**INSTrument:CREate:REPLace <ChannelName1>,<ChannelType>,<ChannelName2>**

This command replaces a channel with another one.

**Setting parameters:**

<ChannelName1> String containing the name of the channel you want to replace.

<ChannelType> Channel type of the new channel.  
For a list of available channel types see [INSTrument:LIST?](#) on page 424.

<ChannelName2> String containing the name of the new channel.  
Note: If the specified name for a new channel already exists, the default name, extended by a sequential number, is used for the new channel (see [INSTrument:LIST?](#) on page 424).  
Channel names can have a maximum of 31 characters, and must be compatible with the Windows conventions for file names. In particular, they must not contain special characters such as ":", "\*", "?".

**Example:** `INST:CRE:REPL 'Receiver',REC,'REC2'`  
Replaces the channel named "Receiver" by a new channel of type "Receiver" named "REC2".

**Usage:** Setting only

**Manual operation:** See "[Replace Current Channel](#)" on page 85

**INSTrument:DELeTe** <ChannelName>

This command deletes a channel.

If you delete the last channel, the default "Receiver" channel is activated.

**Parameters:**

<ChannelName> String containing the name of the channel you want to delete.  
A channel must exist in order to be able delete it.

**Example:** `INST:DEL 'Receiver'`  
Deletes the channel with the name 'Receiver'.

**Usage:** Event

**INSTrument:LIST?**

This command queries all active channels. This is useful in order to obtain the names of the existing channels, which are required in order to replace or delete the channels.

**Return values:**

<ChannelType>,  
<ChannelName> For each channel, the command returns the channel type and channel name (see tables below).  
Tip: to change the channel name, use the [INSTrument:REName](#) command.

**Example:** `INST:LIST?`  
Result for 2 channels:  
'REC','Receiver','REC','Receiver2'

**Usage:** Query only

**Table 13-2: Available channel types and default channel names**

Application	<ChannelType> Parameter	Default Channel Name*)
Receiver	RECEIVER	Receiver
CISPR APD	n/a Use <code>CALCulate:STATistics:CAPD[:STATe]</code> Use <code>CALCulate:STATistics:CAPD[:STATe]</code>	CISPR APD
Spectrum	SANALYZER	Spectrum
I/Q Analyzer	IQ	IQ Analyzer
Real-Time Spectrum	RTIM	Real-Time Spectrum

Note: the default channel name is also listed in the table. If the specified name for a new channel already exists, the default name, extended by a sequential number, is used for the new channel.

**INSTrument:REName** <ChannelName1>, <ChannelName2>

This command renames a channel.

**Parameters:**

<ChannelName1> String containing the name of the channel you want to rename.

<ChannelName2> String containing the new channel name.  
Note that you cannot assign an existing channel name to a new channel; this will cause an error.  
Channel names can have a maximum of 31 characters, and must be compatible with the Windows conventions for file names. In particular, they must not contain special characters such as ":", "\*", "?".

**Example:** `INST:REN 'Receiver', 'REC'`  
Renames the channel with the name 'Receiver' to 'REC'.

**Usage:** Setting only

**INSTrument[:SElect]** <ChannelType> | <ChannelName>

This command activates a new channel with the defined channel type, or selects an existing channel with the specified name.

Also see

- [INSTrument:CREate\[:NEW\]](#) on page 423

**Parameters:**

<ChannelType> Channel type of the new channel.  
For a list of available channel types see [INSTrument:LIST?](#) on page 424.

<ChannelName> String containing the name of the channel.



- Example:**           INST IQ  
 Activates a channel for the I/Q Analyzer application (evaluation mode).  
 INST 'MyIQSpectrum'  
 Selects the channel named 'MyIQSpectrum' (for example before executing further commands for that channel).
- Manual operation:** See "Receiver" on page 82  
 See "CISPR APD" on page 83  
 See "Spectrum" on page 83  
 See "I/Q Analyzer" on page 83  
 See "Analog Demodulation" on page 83  
 See "Real-Time Spectrum" on page 83  
 See "New Channel" on page 85

## 13.5 Measurements and Result Displays

- [Measurement Control](#).....426
- [Measurement Sequences](#).....430
- [Result Retrieval](#).....433
- [Bargraph Configuration](#).....438
- [Scan Configuration](#).....440
- [Scan Table Configuration](#).....442
- [Peak Search](#).....450
- [Peak List](#).....455
- [Final Measurement \(and Trace\) Configuration](#).....460
- [Final Results](#).....464
- [LISN Configuration](#).....468
- [CISPR APD Measurement Configuration](#).....470
- [Programming Example: Performing a Sequence of Measurements](#).....471

### 13.5.1 Measurement Control

- [ABORT](#).....426
- [HOLD](#).....427
- [INITiate<n>:CONMeas](#).....427
- [INITiate<n>:CONTinuous](#).....428
- [INITiate<n>:EMITest](#).....429
- [INITiate<n>:FMEasurement](#).....429
- [INITiate<n>:\[IMMediate\]](#).....429

---

#### ABORT

This command aborts the measurement in the current measurement channel and resets the trigger system.

To prevent overlapping execution of the subsequent command before the measurement has been aborted successfully, use the `*OPC` or `*WAI` command after `ABORT` and before the next command.

To abort a sequence of measurements by the Sequencer, use the `INITiate<n>:SEQuencer:ABORT` command.

#### Note on blocked remote control programs:

If a sequential command cannot be completed, for example because a triggered sweep never receives a trigger, the remote control program will never finish. The remote channel to the R&S ESW is blocked for further commands. In this case, you must interrupt processing on the remote channel first to abort the measurement.

To do so, send a "Device Clear" command from the control instrument to the R&S ESW on a parallel channel to clear all currently active remote channels. Depending on the used interface and protocol, send the following commands:

- **Visa:** `viClear()`
- **GPIB:** `ibclr()`
- **RSIB:** `RSDLLibclr()`

Now you can send the `ABORT` command on the remote channel that runs the measurement.

**Example:** `ABOR;INIT:IMM`  
Aborts the measurement and restarts it.

**Usage:** Event

## HOLD

This command interrupts (holds) a scan.

To resume the scan, use `INITiate<n>[:IMMediate]` on page 429.

**Example:** `HOLD`  
Interrupts the scan.

**Usage:** Event

## INITiate<n>:CONMeas

This command resumes a scan that was interrupted by a transducer stop at the current receiver frequency.

If the scan was interrupted by the `HOLD` command, you have to resume it with `INITiate<n>[:IMMediate]`.

**Suffix:**  
<n> 1 | 2  
INITiate1 is irrelevant.  
INITiate2 resumes the scan.

**Example:**            `INIT2:CONT OFF`  
                          `SWE:COUN 20`  
                          Configures a single measurement that is averaged over 20 measurements.  
                          `INIT2;*WAI`  
                          Starts the measurement and waits for the end of the 20 scans.  
                          `INIT2:CONM;*WAI`  
                          Continues the measurement (next 20 sequences) and waits for the end.

**Usage:**             Event

---

### **INITiate<n>:CONTinuous <State>**

This command controls the measurement mode for an individual channel.

Note that in single measurement mode, you can synchronize to the end of the measurement with `*OPC`, `*OPC?` or `*WAI`. In continuous measurement mode, synchronization to the end of the measurement is not possible. Thus, it is not recommended that you use continuous measurement mode in remote control, as results like trace data or markers are only valid after a single measurement end synchronization.

For details on synchronization see [Chapter 12.1.6, "Command Sequence and Synchronization"](#), on page 363.

If the measurement mode is changed for a channel while the Sequencer is active (see [INITiate<n>:SEQuencer:IMMediate](#) on page 431) the mode is only considered the next time the measurement in that channel is activated by the Sequencer.

#### **Suffix:**

<n>                    1 | 2  
                          `INITiate1` selects single or continuous bargraph measurements.  
                          `INITiate2` selects single or continuous scans.

#### **Parameters:**

<State>             `ON | OFF | 0 | 1`  
                          **ON | 1**  
                          Continuous measurement  
                          **OFF | 0**  
                          Single measurement  
                          `*RST:        1`

**Example:**            `INIT:CONT OFF`  
                          Switches the measurement mode to single measurement.  
                          `INIT:CONT ON`  
                          Switches the measurement mode to continuous measurement.

**Manual operation:** See ["Performing continuous measurements"](#) on page 90  
                          See ["Performing single measurements"](#) on page 91

---

**INITiate<n>:EMITest**

This command initiates an automated test sequence.

The sequence consists of a scan, a peak search and a final measurement.

When you are running a continuous measurement, you have to stop the scan deliberately (with [ABORT](#)) before the peak search is performed. For a single measurement, the R&S ESW automatically performs the peak search after number of scans defined by the scan count has been performed.

**Suffix:**

<n> irrelevant

**Example:**

INIT2:EMIT

Starts the test sequence.

**Usage:**

Event

**Manual operation:** See "[Performing single measurements](#)" on page 91

---

**INITiate<n>:FMEasurement**

This command initiates a final measurement based on the peak list.

**Suffix:**

<n> irrelevant

**Example:**

INIT2:FME

Starts the final measurement.

**Usage:**

Event

**Manual operation:** See "[Performing single measurements](#)" on page 91

---

**INITiate<n>:[IMMEDIATE]**

The command initiates a new measurement.

For a single measurement, the R&S ESW stops measuring when it has reached the end frequency. When you start a continuous measurement, it stops only if you abort it deliberately.

If you are using trace modes MAXHold, MINHold and AVERage, previous results are reset when you restart the measurement.

- **Single measurements**

Synchronization to the end of the measurement is possible with \*OPC, \*OPC? or \*WAI.

- **Continuous measurements**

Synchronization to the end of the measurement is not possible.

It is thus recommended to use a single measurement for remote controlled measurements, because results like trace data or markers are only valid after synchronization.

<b>Suffix:</b>	
<n>	1   2 INITiate1 initiates a bargraph measurement. INITiate2 initiates a scan.
<b>Example:</b>	INIT2:CONT OFF SWE:COUN 20 INIT2;*WAI Starts a single scan (with a scan count = 20), and waits until the measurement is done.
<b>Usage:</b>	Event
<b>Manual operation:</b>	See "Performing continuous measurements" on page 90 See "Performing single measurements" on page 91

### 13.5.2 Measurement Sequences

CONFigure:RECeiver:MEASurement[:DEFault].....	430
INITiate<n>:SEQuencer:ABORt.....	430
INITiate<n>:SEQuencer:IMMediate.....	431
INITiate<n>:SEQuencer:MODE.....	431
SYSTem:SEQuencer.....	432

---

#### CONFigure:RECeiver:MEASurement[:DEFault] <Mode>

This command selects the measurement performed in a Receiver channel during measurement sequences.

[More information](#)

#### Parameters:

<Mode>	<b>BARGraph</b> Performs a bargraph measurement.
	<b>NONE</b> Performs no measurement.
	<b>SCAN</b> Performs a scan.
	*RST:       SCAN

**Example:**       CONF:REC:MEAS BARG  
Performs a bargraph measurement in a measurement sequence.

---

#### INITiate<n>:SEQuencer:ABORt

This command stops the currently active sequence of measurements. The Sequencer itself is not deactivated, so you can start a new sequence immediately using [INITiate<n>:SEQuencer:IMMediate](#) on page 431.

To deactivate the Sequencer use [SYSTem:SEQuencer](#) on page 432.

**Suffix:**

&lt;n&gt; irrelevant

**Usage:**

Event

**Manual operation:** See " [Sequencer State](#) " on page 88**INITiate<n>:SEQuencer:IMMEDIATE**

This command starts a new sequence of measurements by the Sequencer.

Before this command can be executed, the Sequencer must be activated (see [SYSTem:SEQuencer](#) on page 432).

**Suffix:**

&lt;n&gt; irrelevant

**Example:**

SYST:SEQ ON

Activates the Sequencer.

INIT:SEQ:MODE SING

Sets single sequence mode so each active measurement will be performed once.

INIT:SEQ:IMM

Starts the sequential measurements.

**Usage:**

Event

**Manual operation:** See " [Sequencer State](#) " on page 88**INITiate<n>:SEQuencer:MODE <Mode>**

This command selects the way the R&S ESW application performs measurements sequentially.

Before this command can be executed, the Sequencer must be activated (see [SYSTem:SEQuencer](#) on page 432).

A detailed programming example is provided in [Chapter 13.5.13, "Programming Example: Performing a Sequence of Measurements"](#), on page 471.

**Note:** In order to synchronize to the end of a sequential measurement using \*OPC, \*OPC? or \*WAI you must use SINGle Sequence mode.

For details on synchronization see [Chapter 12.1.6, "Command Sequence and Synchronization"](#), on page 363

**Suffix:**

&lt;n&gt; irrelevant

**Parameters:**

&lt;Mode&gt;

**SINGle**

Each measurement is performed once (regardless of the channel's sweep mode), considering each channels' sweep count, until all measurements in all active channels have been performed.

**CONTInuous**

The measurements in each active channel are performed one after the other, repeatedly (regardless of the channel's sweep mode), in the same order, until the Sequencer is stopped.

**CDEFined**

First, a single sequence is performed. Then, only those channels in continuous sweep mode (`INIT:CONT ON`) are repeated.

\*RST:       CONTInuous

**Example:**

`SYST:SEQ ON`

Activates the Sequencer.

`INIT:SEQ:MODE SING`

Sets single sequence mode so each active measurement will be performed once.

`INIT:SEQ:IMM`

Starts the sequential measurements.

**Manual operation:** See "[Sequencer Mode](#)" on page 88

**SYSTem:SEQuencer <State>**

This command turns the Sequencer on and off. The Sequencer must be active before any other Sequencer commands (`INIT:SEQ...`) are executed, otherwise an error will occur.

A detailed programming example is provided in [Chapter 13.5.13, "Programming Example: Performing a Sequence of Measurements"](#), on page 471.

**Parameters:**

&lt;State&gt;

ON | OFF | 0 | 1

**ON | 1**

The Sequencer is activated and a sequential measurement is started immediately.

**OFF | 0**

The Sequencer is deactivated. Any running sequential measurements are stopped. Further Sequencer commands (`INIT:SEQ...`) are not available.

\*RST:       0

**Example:**

```

SYST:SEQ ON
Activates the Sequencer.
INIT:SEQ:MODE SING
Sets single Sequencer mode so each active measurement will
be performed once.
INIT:SEQ:IMM
Starts the sequential measurements.
SYST:SEQ OFF

```

**Manual operation:** See " [Sequencer State](#) " on page 88

### 13.5.3 Result Retrieval

- [Trace Data and Result Query](#)..... 433

#### 13.5.3.1 Trace Data and Result Query

This section contains information on the `TRACe:DATA` command and a detailed description of the characteristics of that command. Basically, the command queries the results of the current measurement. The command supports various SCPI parameters in combination with the query. Each SCPI parameter returns a different aspect of the measurement.

The format of the return values is either in ASCII or binary characters and depends on the format you have set with `FORMat[:DATA]` on page 568.

#### Querying trace data

The SCPI parameters `TRACE1 | ... | TRACE6` return the trace data for the corresponding trace.

#### Example:

```
TRAC? TRACE1
```

The number of results depends on the currently selected number of sweep points. For each sweep point, the command returns one level value. The unit depends on the measurement and on the unit you have currently set.

The trace has to be active for the command to work.

When you have selected `trace mode TRD`, only the `TRACE1` parameter is available. It returns the characteristics of the transducer's correction values over the currently selected frequency range.

#### Querying bargraph results

The SCPI parameters `SINGLE` and `PHOLD` return the results of the bargraph measurement.

`SINGLE` returns the current bargraph results for each active bargraph detector.

The order of detectors is as shown in the user interface. Inactive detectors are ignored.



**Example:**

```
TRAC? SINGLE
```

PHOLD returns the bargraph maxhold results for each active bargraph detector.

Each result is made up out of two values:

- Absolute level
- Frequency

The order of detectors is as shown in the user interface. Inactive detectors are ignored.

**Example:**

```
TRAC? PHOLD
```

**Querying scan characteristics**

The SCPI parameter `SCAN` returns the scan characteristics while the scan is running.

The number of returned results depends on the scan settings.

The type of returned data is as follows:

- 4 byte, trace status:
  - bit 0 to 9 represent the number of the scan range
  - bit 10 represents the last block of a scan range
  - bit 11 represents the last block of the last scan range
  - bit 12 represents the last of all blocks (for multiple scans after the last scan)

When number of scan ranges greater than 10:

  - bit 16 to 31 represent a value that has to be added to the bit coded range number (bit 0 to bit 9) to get the number of scan ranges. Example: bit 16 to 31 represent the value "20", bit 0 to 9 represent the value "5"; in that case the complete number of scan ranges is "25".
- 4 byte, number *n* of measurement results contained in one trace
- 4 byte, bit 0 represents the state of trace 1 (0/1)
- 4 byte, bit 0 represents the state of trace 2 (0/1)
- 4 byte, bit 0 represents the state of trace 3 (0/1)
- 4 byte, bit 0 represents the state of trace 4 (0/1)
- **Note:**

If more than 4 traces are active, the state of trace 5 and 6 is indicated by an additional bit (bit 8) in the UINT32 field of trace 1 and 2.
- n\*4 byte, measurement results for trace 1; only if trace 1 is active
- n\*4 byte, measurement results for trace 2; only if trace 2 is active
- n\*4 byte, measurement results for trace 3; only if trace 3 is active
- n\*4 byte, measurement results for trace 4; only if trace 4 is active
- n\*4 byte, measurement results for trace 5; only if trace 5 is active
- n\*4 byte, measurement results for trace 6; only if trace 6 is active
- n\*1 byte, status information for each measurement result

→ bit 2 represents overrange for trace 1 to trace 6

The data is always returned in binary format (`FORM REAL, 32`).

Note that the `SCAN` parameter only works while the scan is actually running.

**Example:**

```
TRAC? SCAN
```

**Querying results for a peak search**

The SCPI parameters `PLIST1 | ... | PLIST6` returns the results of a peak search for a particular trace or detector (1 to 6).

Each result is made up out of three values:

- 4 byte, frequency
- 4 byte, absolute level
- 4 byte, Delta between absolute level and limit line value at corresponding frequency  
If no limit line is active, the delta value is set to 0.0

The trace has to be active for the command to work.

**Example:**

```
TRAC? PLIST3
```

**Querying results for the final measurement**

The SCPI parameters `FINAL1 | ... | FINAL6` return the results of the final measurement for a particular trace or detector (1 to 6).

Each result is made up out of three values:

- 4 byte, frequency
- 4 byte, absolute level
- 4 byte, Delta between absolute level and limit line value at corresponding frequency  
If no limit line is active, the delta value is set to 0.0

The trace has to be active for the command to work.

**Querying the status of the measurement results**

The SCPI parameter `STATUS` returns the status information for each measurement result. Thus, the number of returned values depends on the number of measurement results  $n$ . For each measurement result, the parameter queries 1 byte of status information.

→ bit 2 represents overrange for trace 1 to trace 6

Note that the `SCAN` parameter only works while the scan is actually running.

**Example:**

```
TRAC? STATUS
```

**Querying spectrogram data**

The SCPI parameter `SGRam` returns the contents of the spectrogram.

For every frame (horizontal line) in the spectrogram, the command returns the power levels that have been measured, one for each sweep or measurement point. The number of frames depends on the size of the history depth. The power level depends on the unit you have currently set.

**TRACe<n>[:DATA] <ResultType>**

This command queries current trace data and measurement results.

The data format depends on `FORMat [:DATA]`.

Reading out trace data in IF analysis is possible with `TRACe<n> : IF [:DATA]`.

**Suffix:**

<n> [Window](#)

**Parameters:**

<ResultType>

**TRACE1 | ... | TRACE6**

See ["Querying trace data"](#) on page 433.

**FINAL1 | ... | FINAL6**

See ["Querying results for the final measurement"](#) on page 435.

**PLIST1 | ... | PLIST6**

See ["Querying results for a peak search"](#) on page 435.

**PHOLD**

See ["Querying bargraph results"](#) on page 433.

**SCAN**

See ["Querying scan characteristics"](#) on page 434.

**SGRam | SPECTrogram**

See ["Querying spectrogram data"](#) on page 436.

**SINGLE**

See ["Querying bargraph results"](#) on page 433.

**STATUS**

See ["Querying scan characteristics"](#) on page 434.

**Example:**

```
TRAC? TRACE1
```

Queries the level for each trace point of trace 1.

**TRACe<n>:FEED:CONTrol<t> <Occasion>**

This command turns block data transmission during a scan on and off.

The availability of data is reported in the `STATus:OPERation` register.

The block size depends on scan time and the upper limit defined by `TRACe<n> : POINTs` on page 437.

<b>Suffix:</b>	
<n>	irrelevant
<t>	Selects a trace.
<b>Parameters:</b>	
<Occasion>	<b>ALWays</b> Block data transmission is on.
	<b>NEVer</b> Block data transmission is off.
	*RST: NEVER
<b>Example:</b>	TRAC:FEED:CONT ALW Switches to single sweep mode.
<b>Usage:</b>	SCPI confirmed

**TRACe<n>:IF[:DATA] <ResultType>**

This command queries current trace data and measurement results for IF analysis.

The data format depends on FORMat[:DATA].

<b>Suffix:</b>	
<n>	irrelevant
<b>Parameters:</b>	
<ResultType>	<b>TRACE1   ...   TRACE3</b> Returns the level values displayed on the corresponding trace.
<b>Example:</b>	TRAC? TRACE1 Queries the level for each trace point of trace 1.

**TRACe<n>:POINts LIMit, <Points>**

This command defines the maximum number of measurement points that are transferred in one block after using TRAC? SCAN.

The total number of bytes which is transferred depends on the number of active traces.

<b>Suffix:</b>	
<n>	irrelevant
<b>Parameters:</b>	
LIMit	
<Points>	Range: 1 to 10000 *RST: 1000
<b>Example:</b>	TRAC:POIN LIM, 8000 Transfers a maximum of 8000 measurement values per trace with a single query.
<b>Usage:</b>	SCPI confirmed

### 13.5.4 Bargraph Configuration

DISPlay:BARGraph:LEVel:LOWer?	438
DISPlay:BARGraph:LEVel:UPPer?	438
DISPlay:BARGraph:PHOLd:RESet	438
DISPlay:BARGraph:PHOLd[:STATe]	438
DISPlay:BARGraph:TCOupling[:STATe]	439
[SENSe:]DETEctor<t>:RECEiver[:FUNction]	439
[SENSe:]SWEep:TIME	440

#### DISPlay:BARGraph:LEVel:LOWer?

This command queries the level range of the bargraph.

**Return values:**

<Level>                 Lowest level displayed on the bargraph scale.  
 Default unit: depends on the selected unit

**Example:**

DISP: BARG: LEV: LOW?  
 would return, e.g.  
 10

**Usage:**                 Query only

#### DISPlay:BARGraph:LEVel:UPPer?

This command queries the level range of the bargraph.

**Return values:**

<Level>                 Highest level displayed on the bargraph scale.  
 Default unit: depends on the selected unit

**Example:**

DISP: BARG: LEV: UPP?  
 would return, e.g.  
 110

**Usage:**                 Query only

#### DISPlay:BARGraph:PHOLd:RESet

This command resets the bargraph max hold.

**Example:**

DISP: BARG: PHOL: RES  
 Resets the max hold value.

**Usage:**                 Event

**Manual operation:** See "[Bargraph Max Hold](#)" on page 95

#### DISPlay:BARGraph:PHOLd[:STATe] <State>

This command turns the bargraph max hold function on and off.

**Parameters:**

<State> ON | OFF  
 \*RST: OFF

**Example:**

DISP:BARG:PHOL ON  
 Turns on the bargraph max hold.

**Manual operation:** See ["Bargraph Max Hold"](#) on page 95

**DISPlay:BARGraph:TCoupling[:STATe] <State>**

This command couples or decouples the bargraph detector and trace detector used for the scan.

**Parameters:**

<State> ON | OFF  
 \*RST: OFF

**Example:**

DISP:BARG:TCO ON  
 Couples the type and color of bargraph and scan trace.

**Manual operation:** See ["Couple to Scan Trace"](#) on page 95

**[SENSe:]DETEctor<t>:RECEiver[:FUNction] <Detector>**

This command selects the detector for the bargraph measurement.

**Suffix:**

<t> [Trace](#)

**Parameters:**

<Detector> You can select up to four detectors, one for each active bargraph:

<Detector>, [<Detector>, <Detector>, <Detector>]

**AVERage**

Selects the Average detector.

**CAverage**

Selects the CISPR Average detector.

**CRMS**

Selects the CISPR RMS detector.

**NEGative**

Selects the Min Peak detector.

**POSitive**

Selects the Max Peak detector.

**QPEak**

Selects the Quasipeak detector.

**RMS**

Selects the RMS detector.

\*RST: AVERage

**Example:** //Select bargraph detector  
DET:REC POS, AVER, RMS

**Manual operation:** See ["Detector"](#) on page 127

**[SENSe:]SWEep:TIME <Time>**

This command defines the measurement or acquisition time for bargraph measurements.

For scans not based on a scan table, the command also defines the measurement time for the scan.

**Parameters:**

<Time>                    <numeric value>  
Range:            5  $\mu$ s to 100 s  
\*RST:            0.1  
Default unit: s

**Example:** Define measurement time  
SWE:TIME 10s

**Manual operation:** See ["Measurement Time"](#) on page 95

### 13.5.5 Scan Configuration

Commands to configure scans described elsewhere.

- See [Chapter 13.5.6, "Scan Table Configuration"](#), on page 442.

<a href="#">[SENSe:]FREQuency:MODe</a> .....	440
<a href="#">[SENSe:]SCAN&lt;sr&gt;:TDOMain</a> .....	441
<a href="#">[SENSe:]FREQuency:TDOptim</a> .....	441

**[SENSe:]FREQuency:MODe <Mode>**

This command selects the scan mode.

**Parameters:**

&lt;Mode&gt;

**FIXed | CW**

Selects fixed frequency scans.

Define the frequency with `[SENSe:]FREQuency:CENTer`.**SCAN | SWEEp**

Selects stepped scans in the frequency domain.

Define the frequency range with:

- `[SENSe:]FREQuency:START`
- `[SENSe:]FREQuency:STOP`
- `[SENSe:]SCAN<sr>:START`
- `[SENSe:]SCAN<sr>:STOP`

**TDOMain**

Selects time domain scans in the frequency domain.

Define the frequency range with the commands for stepped scans.

\*RST: TDOMain

**Example:**

```
//Selects stepped scan
FREQ:MODE SCAN
```

**Usage:**

SCPI confirmed

**Manual operation:** See ["Selecting the scan type"](#) on page 108**[SENSe:]SCAN<sr>:TDOMain <Time>**

This command defines the measurement time for fixed frequency scans.

**Suffix:**

&lt;sr&gt; irrelevant

**Parameters:**

&lt;Time&gt;

&lt;numeric value&gt;

Measurement time in seconds.

The range indicated below is the maximum range. The actual range depends on the measurement time defined with `[SENSe:]SWEEp:TIME` on page 440.

Range: 10 ms to 10000 s

\*RST: 10.0

Default unit: s

**Example:**

```
//Define measurement time
SCAN:TDOM 100 s
```

**Manual operation:** See ["Measurement Time"](#) on page 95**[SENSe:]FREQuency:TDOptim <State>**

This command selects the mode for time domain scans.



**Parameters:**

&lt;State&gt;

**AUTO**

Effects depend on selected detectors.

Measurements with CISPR detectors: Automatic mode applies a small analysis bandwidth (FFT size) in favor of a high dynamic range.

Measurements without CISPR detectors: Automatic mode applies a large analysis bandwidth (FFT size) in favor of an increased measurement speed.

**DYNAMIC**

Always applies a small analysis bandwidth (FFT size) in favor of a high dynamic range, regardless of the selected detectors.

\*RST: AUTO

**Example:**//Apply small FFT size  
FREQ:TDOF DYN**Usage:**

SCPI confirmed

**Manual operation:** See "[Selecting the mode for time domain scans](#)" on page 109

### 13.5.6 Scan Table Configuration

[SENSe:]DETECTOR<t>[:FUNCTION].....	442
[SENSe:]FREQUENCY:START.....	443
[SENSe:]FREQUENCY:STOP.....	443
[SENSe:]SCAN<sr>:BANDWIDTH:RESOLUTION.....	444
[SENSe:]SCAN<sr>:BARS.....	444
[SENSe:]SCAN<sr>:INPUT:ATTENUATION:AUTO.....	445
[SENSe:]SCAN<sr>:INPUT:ATTENUATION[:VALUE].....	445
[SENSe:]SCAN<sr>:INPUT:GAIN:AUTO.....	445
[SENSe:]SCAN<sr>:INPUT:GAIN:LNA:AUTO.....	446
[SENSe:]SCAN<sr>:INPUT:GAIN:LNA:STATE.....	446
[SENSe:]SCAN<sr>:INPUT:GAIN[:STATE].....	446
[SENSe:]SCAN<sr>:INPUT:TYPE.....	447
[SENSe:]SCAN<sr>:NAME.....	447
[SENSe:]SCAN<sr>:RANGES[:COUNT].....	447
[SENSe:]SCAN<sr>:START.....	448
[SENSe:]SCAN<sr>:STEP.....	448
[SENSe:]SCAN<sr>:STOP.....	449
[SENSe:]SCAN<sr>:TIME.....	449
[SENSe:]SWEPT:COUNT.....	449
[SENSe:]SWEPT:SPACING.....	450

**[SENSe:]DETECTOR<t>[:FUNCTION] <Detector>**

This command selects the detector for the scan.

In the Spectrum application, it selects the detector in general.

**Suffix:**<t> [Trace](#)**Parameters:**

&lt;Detector&gt;

**AVERage**

Selects the Average detector.

**CAVerage**

Selects the CISPR Average detector.

**CRMS**

Selects the CISPR RMS detector.

**NEGative**

Selects the Min Peak detector.

**POSitive**

Selects the Max Peak detector.

**QPEak**

Selects the Quasipeak detector.

**RMS**

Selects the RMS detector.

\*RST: POSitive

**Example:**

```
//Select scan detector
DET RMS
```

**Usage:**

SCPI confirmed

**Manual operation:**See "[Detector](#)" on page 127**[SENSe:]FREQuency:STARt <Frequency>**

This command defines the start frequency of a scan.

In the spectrum application, the command defines the start frequency of a measurement.

**Parameters:**

&lt;Frequency&gt;

&lt;numeric value&gt;

Range: Refer to the datasheet

\*RST: depends on application

Default unit: Hz

**Example:**

```
//Define start frequency
FREQ:STAR 30 kHz
```

**Manual operation:**

See "[Defining a frequency range for the scan](#)" on page 112  
 See "[Start / Stop Frequency](#)" on page 172

**[SENSe:]FREQuency:STOP <Frequency>**

This command defines the stop frequency of a scan.

In the Spectrum application, the command defines the stop frequency of a measurement.

**Parameters:**

<Frequency>            <numeric value>  
 Range:            Refer to the datasheet  
 \*RST:            depends on application  
 Default unit: Hz

**Example:**

```
//Define stop frequency
FREQ:STOP 100MHz
```

**Manual operation:**

See ["Defining a frequency range for the scan"](#) on page 112  
 See ["Start / Stop Frequency"](#) on page 172

**[SENSe:]SCAN<sr>:BANDwidth:RESolution <Bandwidth>**

This command defines the resolution bandwidth applied in the selected scan range.

**Suffix:**

<sr>                    1..100  
 Selects the scan range.

**Parameters:**

<Bandwidth>           <numeric value>  
 If you enter a resolution bandwidth that is not supported, the R&S ESW uses the next available bandwidth instead.  
 Range:            Refer to datasheet  
 Default unit: Hz

**Example:**

```
//Define a measurement bandwidth for the 4th scan range
SCAN4:BAND:RES 1MHz
```

**Manual operation:**

See ["Measurement Bandwidth"](#) on page 96

**[SENSe:]SCAN<sr>:BARS <State>**

This command turns the display of the bars indicating the size of a scan range on and off.

**Suffix:**

<sr>                    irrelevant

**Parameters:**

<State>                ON | OFF | 1 | 0  
 \*RST:                ON

**Example:**

```
//Turn on range bars
SCAN:BARS ON
```

**Usage:**

SCPI confirmed

**Manual operation:**

See ["Displaying range bars"](#) on page 113

**[SENSe:]SCAN<sr>:INPut:ATTenuation:AUTO <State>**

This command turns auto ranging in a scan range on and off.

**Suffix:**

<range> 1..100  
Selects the scan range.

**Parameters:**

<State> ON | OFF | 1 | 0  
\*RST: OFF

**Example:** //Turn off auto ranging in the 4th scan range  
SCAN4:INP:ATT:AUTO OFF

**Manual operation:** See "[Auto Range](#)" on page 115

**[SENSe:]SCAN<sr>:INPut:ATTenuation[:VALue] <Attenuation>**

This command defines the attenuation level applied in the selected scan range.

**Suffix:**

<sr> 1..100  
Selects the scan range.

**Parameters:**

<Attenuation> <numeric value> (integer only)  
Range: 0 dB to 79 dB  
Increment: 1 dB  
\*RST: 10 dB  
Default unit: dB

**Example:** //Define attenuation for the 4th scan range.  
SCAN4:INP:ATT 30dB

**Manual operation:** See "[Attenuation](#)" on page 116

**[SENSe:]SCAN<sr>:INPut:GAIN:AUTO <State>**

This command includes and excludes the preamplifier from the auto ranging feature.

**Suffix:**

<sr> 1..100  
Selects the scan range.

**Parameters:**

<State> ON | OFF | 1 | 0  
\*RST: OFF

**Example:** //Automatically determine if the preamplifier is used or not  
SCAN1:INP:GAIN:AUTO ON

**Manual operation:** See "[Preamplifier](#)" on page 116

**[SENSe:]SCAN<sr>:INPut:GAIN:LNA:AUTO <State>**

This command includes and excludes the optional low noise amplifier from the auto ranging feature.

This command is available with the optional low noise amplifier.

**Suffix:**

<sr> 1..100  
Selects the scan range.

**Parameters:**

<State> ON | OFF | 1 | 0  
\*RST: OFF

**Example:** //Automatic selection if amplifier is used or not  
SCAN1:INP:GAIN:LNA:AUTO ON

**Usage:** SCPI confirmed

**Manual operation:** See "[Preamplifier](#)" on page 116

**[SENSe:]SCAN<sr>:INPut:GAIN:LNA:STATe <State>**

This command turns the optional low noise amplifier on and off.

Note that it is not possible to use the low noise amplifier and the preamplifier at the same time.

**Suffix:**

<sr> 1..100  
Selects the scan range.

**Parameters:**

<State> ON | OFF | 1 | 0  
\*RST: OFF

**Example:** //Turn on low noise amplifier  
SCAN:INP:GAIN:LNA:STAT ON

**Usage:** SCPI confirmed

**Manual operation:** See "[Preamplifier](#)" on page 116

**[SENSe:]SCAN<sr>:INPut:GAIN[:STATe] <State>**

This command turns the preamplifier in a scan range on and off.

The command is available with the optional preamplifier.

**Suffix:**

<sr> 1..100  
Selects the scan range.

**Parameters:**

<State>           **ON | 1**  
Turns on the preamplifier.

**OFF | 0**  
Turns off the preamplifier.

\*RST:           OFF

**Example:**           //Turn on preamplifier for 4th scan range.  
                      SCAN4:INP:GAIN:STAT ON

**Manual operation:** See "[Preamplifier](#)" on page 116

**[SENSe:]SCAN<sr>:INPut:TYPE <Input>**

This command selects the RF input used for a scan range.

**Suffix:**

<sr>               1..100  
Selects the scan range.

**Parameters:**

<Input>           **INPUT1**  
Selects RF input 1.

**INPUT2**  
Selects RF input 2.

\*RST:           INPUT1

**Example:**           Selects RF input path for the 4th scan range.  
                      SCAN4:INP:TYPE INPUT2

**Manual operation:** See "[Input Selection](#)" on page 117

**[SENSe:]SCAN<sr>:NAME <Name>**

This command changes the name of a scan range.

**Suffix:**

<sr>               1..100  
Selects the scan range.

**Parameters:**

<Name>           String containing the name of the scan range.

**Example:**           //Change name of scan range 4  
                      SCAN4:NAME 'Fourth Range'

**Usage:**           SCPI confirmed

**Manual operation:** See "[Configuring scan ranges](#)" on page 113

**[SENSe:]SCAN<sr>:RANGes[:COUNT] <Range>**

This command defines the number of scan ranges.

**Suffix:**

<sr> irrelevant

**Parameters:**

<Range> <numeric value> (integer only)  
 Number of ranges in the scan table.  
 If you enter the value "0", the R&S ESW ignores the configuration of the scan table. Instead, it performs the measurement based on the current receiver configuration.

Range: 0 to 100  
 \*RST: 2

**Example:**

```
//Define number of scan ranges
SCAN:RANG:COUN 4
```

**Manual operation:** See ["Adding and removing scan ranges"](#) on page 112

**[SENSe:]SCAN<sr>:START <Frequency>**

This command defines the start frequency of a scan range.

**Suffix:**

<sr> 1..100  
 Selects the scan range.

**Parameters:**

<Frequency> <numeric value>  
 Range: Refer to the datasheet  
 \*RST: Depends on the scan range.  
 Default unit: Hz

**Example:**

```
//Define start frequency for 4th scan range
SCAN4:STAR 30MHz
```

**Manual operation:** See ["Range Start and Range Stop"](#) on page 114

**[SENSe:]SCAN<sr>:STEP <Frequency>**

This command defines the frequency stepsize applied in the selected scan range

Available for linear and logarithmic step mode ([\[SENSe:\]SWEep:SPACing](#)).

**Suffix:**

<sr> 1..100  
 Selects the scan range.

**Parameters:**

<Frequency> <numeric value>  
**Linear** step mode: numeric value in %.  
**Logarithmic** step mode: numeric value in Hz.  
 \*RST: Depends on the scan and frequency range.

**Example:** //Define step size for 4th scan range  
 SWE:SPAC LIN  
 SCAN4:STEP 100KHZ

**Manual operation:** See ["Step Size"](#) on page 114

**[SENSe:]SCAN<sr>:STOP <Frequency>**

This command defines the stop frequency of a scan range.

**Suffix:**

<sr> 1..100  
 Selects the scan range.

**Parameters:**

<Frequency> <numeric value>  
 Range: Refer to the datasheet  
 \*RST: Depends on the scan range.  
 Default unit: Hz

**Example:** //Define stop frequency for 4th scan range  
 SCAN4:STOP 500MHZ

**Manual operation:** See ["Range Start and Range Stop"](#) on page 114

**[SENSe:]SCAN<sr>:TIME <Time>**

This command defines the measurement time applied in the selected scan range.

**Suffix:**

<sr> 1..100  
 Selects the scan range.

**Parameters:**

<Time> <numeric value>  
 Range: 100  $\mu$ s to 100 s  
 \*RST: depends on the range  
 Default unit: s

**Example:** //Define measurement time for 4th scan range  
 SCAN4:TIME 1 ms

**Manual operation:** See ["Measurement Time"](#) on page 95

**[SENSe:]SWEep:COUNT <Measurements>**

This command defines the number of measurements that the application uses to average traces.

For continuous measurements, the application calculates the moving average over the average count.



For single measurements, the application stops the measurement and calculates the average after the average count has been reached.

**Parameters:**

<Measurements> <numeric value> (integer only)  
 Number of measurements considered in calculating an average trace.  
 When you set a count of 1, the R&S ESW performs a single measurement over the selected scan range.  
 Range: 0 to 32767  
 \*RST: 0

**Example:**

```
//10 measurements in single measurement mode
SWE:COUN 10
INIT:CONT OFF
//Start sweep and wait for its end
INIT;*WAI
```

**Manual operation:** See "[Scan Count](#)" on page 108

**[SENSe:]SWEep:SPACing <StepMode>**

This command selects the frequency step mode.

Note that the command has no effect on the scale and display of the frequency axis.

**Parameters:**

<StepMode> **LINEar**  
 Linear frequency steps with a fix stepsize.  
**LOGarithmic**  
 Logarithmic frequency steps with the stepsize being a percentage of the current frequency.  
**AUTO**  
 The stepsize is coupled to the resolution bandwidth to get the best measurement results.  
 \*RST: AUTO

**Example:**

```
//Select logarithmic frequency steps
SWE:SPAC LOG
```

**Manual operation:** See "[Selecting the frequency step mode](#)" on page 113

### 13.5.7 Peak Search

Commands to configure the peak search described elsewhere.

- [FORMat:DEXPort:DSEPARATOR](#) on page 569

<a href="#">CALCulate&lt;n&gt;:MARKer&lt;m&gt;:PEXCursion</a> .....	451
<a href="#">CALCulate&lt;n&gt;:PSEarch:ADD</a> .....	451
<a href="#">CALCulate&lt;n&gt;:PEAKsearch:ADD</a> .....	451
<a href="#">CALCulate&lt;n&gt;:PSEarch:AUTO</a> .....	452

CALCulate<n>:PEAKsearch:AUTO.....	452
CALCulate<n>:PSEarch:CLEar[:IMMEDIATE].....	452
CALCulate<n>:PEAKsearch:CLEar[:IMMEDIATE].....	452
CALCulate<n>:PSEarch[:IMMEDIATE].....	452
CALCulate<n>:PEAKsearch[:IMMEDIATE].....	452
CALCulate<n>:PSEarch:MARGIN.....	453
CALCulate<n>:PEAKsearch:MARGIN.....	453
CALCulate<n>:PSEarch:METHod.....	453
CALCulate<n>:PEAKsearch:METHod.....	453
CALCulate<n>:PSEarch:SUBRanges:PCOunt.....	453
CALCulate<n>:PEAKsearch:SUBRanges:PCOunt.....	453
CALCulate<n>:PSEarch:SUBRanges.....	454
CALCulate<n>:PEAKsearch:SUBRanges.....	454
DISPlay[:WINDow<n>]:TRACe<t>:SYMBOL.....	454
MMEMory:STORE:FINal.....	455
MMEMory:STORE:PLISt.....	455

---

#### CALCulate<n>:MARKer<m>:PEXCursion <Excursion>

This command defines the peak excursion (for *all* markers in *all* windows).

The peak excursion sets the requirements for a peak to be detected during a peak search.

The unit depends on the measurement.

##### Suffix:

<n>, <m>                    irrelevant

##### Parameters:

<Excursion>                The excursion is the distance to a trace maximum that must be attained before a new maximum is recognized, or the distance to a trace minimum that must be attained before a new minimum is recognized

\*RST:                    6 dB

##### Example:

CALC:MARK:PEXC 10dB  
 Defines peak excursion as 10 dB.

**Manual operation:**    See "[Defining peak characteristics](#)" on page 120  
                                   See "[Peak Excursion](#)" on page 227

---

#### CALCulate<n>:PSEarch:ADD <Frequency>

#### CALCulate<n>:PEAKsearch:ADD <Frequency>

This command manually adds a particular frequency to the peak list, regardless if the level threshold conditions have been fulfilled for that frequency.

Note that the frequency has to be in the displayed frequency range.

##### Suffix:

<n>                            irrelevant

**Setting parameters:**

<Frequency> Numeric value in Hz. The range depends on the measurement.

**Example:**

`CALC:PEAK:ADD 93MHz`

Adds the frequency 93 MHz to the peak list.

**Usage:**

Setting only

**Manual operation:**

See ["Editing a peak list"](#) on page 122

See ["Adding the current frequency to the peak list"](#) on page 123

**CALCulate<n>:PSEarch:AUTO <State>**

**CALCulate<n>:PEAKsearch:AUTO <State>**

This command turns an automatic peak search on and off.

When you turn on this feature, the R&S ESW performs a scan and a peak search in an automated test sequence, but no final measurement.

**Suffix:**

<n> irrelevant

**Parameters:**

<State> ON | OFF

\*RST: OFF

**Example:**

`CALC:PEAK:AUTO ON`

Turns on the peak search.

**Usage:**

SCPI confirmed

**CALCulate<n>:PSEarch:CLEAR[:IMMEDIATE]**

**CALCulate<n>:PEAKsearch:CLEAR[:IMMEDIATE]**

This command deletes the contents of a peak list.

**Suffix:**

<n> irrelevant

**Example:**

`CALC:PEAK:CLEAR`

Clears the peak list.

**Usage:**

Event

**Manual operation:**

See ["Editing a peak list"](#) on page 122

**CALCulate<n>:PSEarch[:IMMEDIATE]**

**CALCulate<n>:PEAKsearch[:IMMEDIATE]**

This command initiates a peak search.

**Example:**

`CALC:PEAK`

Initiates a peak search.

**Usage:**

Event

---

**CALCulate<n>:PSEarch:MARGin** <Margin>

**CALCulate<n>:PEAKsearch:MARGin** <Margin>

This command defines the limit line margin that is considered during a peak search.

**Suffix:**

<n> irrelevant

**Parameters:**

<Margin> Numeric value in dB.  
 Range: -200 to 200  
 \*RST: 6  
 Default unit: dB

**Example:**

CALC:PEAK:MARG 2  
 Defines a margin of 2 dB.

**Manual operation:** See "[Defining peak characteristics](#)" on page 120

---

**CALCulate<n>:PSEarch:METHod** <Method>

**CALCulate<n>:PEAKsearch:METHod** <Method>

This command selects the way the R&S ESW creates a peak list.

**Suffix:**

<n> irrelevant

**Parameters:**

<Method> **SUBRange**  
 Divides the scan range into smaller subranges and looks for a particular number of peaks in each subrange.  
**PEAK**  
 Looks for a particular number of peaks over the complete scan range.  
 \*RST: PEAK

**Example:**

CALC:PEAK:METH SUBR  
 Divides the scan range into smaller subranges for the peak search.

**Manual operation:** See "[Selecting the peak search method](#)" on page 120

---

**CALCulate<n>:PSEarch:SUBRanges:PCOunt** <Peaks>

**CALCulate<n>:PEAKsearch:SUBRanges:PCOunt** <Peaks>

This command defines the number of peaks to be found in each subrange.

Before you can use this command, you have to select the subrange peak search mode with [CALCulate<n>:PEAKsearch:METHod](#).

**Suffix:**

<n> irrelevant

**Parameters:**

<Peaks> Number of peaks in one subrange.  
 Note that the maximum number of peaks is 500. Thus, the maximum number of peaks per subrange depends on the number of subranges you have defined.

Range: 1 to 10

\*RST: 1

**Example:**

CALC:PEAK:METH SUBR

CALC:PEAK:SUBR 20

CALC:PEAK:SUBR:PCO 5

Looks for 5 peaks in each of 20 subranges.

**Manual operation:** See ["Controlling the size of the peak list"](#) on page 120

**CALCulate<n>:PSEarch:SUBRanges <Peaks> | <Subranges>**

**CALCulate<n>:PEAKsearch:SUBRanges <Peaks> | <Subranges>**

The effects of this command depend on the peak search mode that you have selected.

**Suffix:**

<n> irrelevant

**Parameters:**

<Peaks> If you have selected the "Peaks" search mode, the command defines the number of peaks to look for during the peak search.

Range: 1 to 500

\*RST: 50

<Subranges> If you have selected the Subranges search mode, the command defines the number of subranges that the scan range is split into.

Range: 1 to 50

\*RST: 10

**Example:**

CALC:PEAK:METH SUBR

CALC:PEAK:SUBR 25

Selects a subrange search and defines 25 subranges.

**Manual operation:** See ["Controlling the size of the peak list"](#) on page 120

**DISPlay[:WINDow<n>]:TRACe<t>:SYMBOL <Symbol>**

This command turns the peak labels in the diagram on and off.

**Suffix:**

<n> irrelevant

<t> irrelevant

**Parameters:**

&lt;Symbol&gt;

**CROSSs**

Each peak is labeled by a symbol. The symbol and its color depend on the trace the peak is on.

**OFF**

Peak labels are off.

\*RST: CROSSs

**Example:**

DISP:TRAC:SYMB CROS

**Manual operation:** See "[Displaying peaks as symbols](#)" on page 123

**MMEMory:STORe:FINal** <FileName>

This command exports the contents of the final measurement peak list to a file in ASCII format.

**Setting parameters:**

&lt;FileName&gt;

String containing the file name. The extension of the file is \*.dat.

**Example:**

MMEM:STOR:FIN 'A:\TEST.DAT'

Exports the peak list.

**Usage:**

Setting only

**Manual operation:** See "[Exporting a peak list](#)" on page 123

**MMEMory:STORe:PLISt** <FileName>

This command exports the contents of the final measurement peak list to a file in ASCII format.

**Setting parameters:**

&lt;FileName&gt;

String containing the file name. The extension of the file is \*.dat.

**Example:**

MMEM:STOR:PLIS 'A:\TEST.DAT'

Exports the peak list.

**Usage:**

Setting only

**Manual operation:** See "[Exporting a peak list](#)" on page 123

### 13.5.8 Peak List

<a href="#">CALCulate&lt;n&gt;:PSEarch:PLISt&lt;peak&gt;:ALL?</a> .....	456
<a href="#">CALCulate&lt;n&gt;:PEAKsearch:PLISt&lt;peak&gt;:ALL</a> .....	456
<a href="#">CALCulate&lt;n&gt;:PSEarch:PLISt&lt;peak&gt;:COMMENT</a> .....	456
<a href="#">CALCulate&lt;n&gt;:PEAKsearch:PLISt&lt;peak&gt;:COMMENT</a> .....	456
<a href="#">CALCulate&lt;n&gt;:PSEarch:PLISt&lt;peak&gt;:DELETE</a> .....	457
<a href="#">CALCulate&lt;n&gt;:PEAKsearch:PLISt&lt;peak&gt;:DELETE</a> .....	457

CALCulate<n>:PSEarch:PLISt<peak>:DELTA?	457
CALCulate<n>:PEAKsearch:PLISt<peak>:DELTA?	457
CALCulate<n>:PSEarch:PLISt<peak>:DETECTOR?	457
CALCulate<n>:PEAKsearch:PLISt<peak>:DETECTOR	457
CALCulate<n>:PSEarch:PLISt<peak>:FREQUENCY?	458
CALCulate<n>:PEAKsearch:PLISt<peak>:FREQUENCY?	458
CALCulate<n>:PSEarch:PLISt<peak>:LEVEL?	458
CALCulate<n>:PEAKsearch:PLISt<peak>:LEVEL?	458
CALCulate<n>:PSEarch:PLISt<peak>:SIZE?	459
CALCulate<n>:PEAKsearch:PLISt<peak>:SIZE?	459
CALCulate<n>:PSEarch:PLISt<peak>:TRACE?	459
CALCulate<n>:PEAKsearch:PLISt<peak>:TRACE?	459
CALCulate<n>:PSEarch:PLISt<peak>[:DATA]?	459
CALCulate<n>:PEAKsearch:PLISt<peak>[:DATA]?	459

**CALCulate<n>:PSEarch:PLISt<peak>:ALL?****CALCulate<n>:PEAKsearch:PLISt<peak>:ALL**

This command queries the information for all peaks found in the peak search.

**Suffix:**

<n> irrelevant

<peak> irrelevant

**Return values:**

<Peaks> List of values representing all measured peaks. The size of the list depends on the number of peaks found in the peak search. For each peak, the command returns the following information.  
 <TraceNumber>, <Detector>, <Frequency>, <Level>, <DeltaLimit>, <Comment>, ...  
 <DeltaLimit> is '0' if you use no limit line.  
 <comment> is empty if you have not entered one for the corresponding peak.

**Example:**

```
CALC:PEAK:PLIS?
would return, e.g.
'TRACE1,Quasi-Peak,
4.5e+07,53.99,0,yahoo,TRACE2,Average,
4.5e+07,53.07,0,,TRACE3,RMS,
4.5e+07,50.89,0,,TRACE4,Quasi-Peak,
4.5e+07,53.99,0,,[...]'
```

**Usage:** SCPI confirmed

**CALCulate<n>:PSEarch:PLISt<peak>:COMMENT <Comment>****CALCulate<n>:PEAKsearch:PLISt<peak>:COMMENT <Comment>**

This command assigns a comment to a peak found in the peak search.

**Suffix:**

<n> irrelevant

<peak>	Peak
<b>Parameters:</b>	
<Comment>	String containing the comment.
<b>Example:</b>	<code>CALC:PEAK:PLIS4:COMM 'Woohoo'</code> Defines a comment for the fourth peak.
<b>Usage:</b>	SCPI confirmed

**CALCulate<n>:PSEarch:PLIS<peak>:DELeTe**  
**CALCulate<n>:PEAKsearch:PLIS<peak>:DELeTe**

This command deletes a peak from the peak list.

<b>Suffix:</b>	
<n>	irrelevant
<peak>	Peak
<b>Example:</b>	<code>CALC:PEAK:PLIS4:DEL</code> Deletes the fourth peak from the peak list.
<b>Usage:</b>	Event SCPI confirmed

**CALCulate<n>:PSEarch:PLIS<peak>:DELTA?**  
**CALCulate<n>:PEAKsearch:PLIS<peak>:DELTA?**

This command queries the distance of a peak to the nearest limit line in the peak search.

<b>Suffix:</b>	
<n>	irrelevant
<peak>	Peak
<b>Query parameters:</b>	
<Level>	<numeric value> If you are using no limit line, the return value is '0'.
<b>Example:</b>	<code>CALC:PEAK:PLIS4:DELTA?</code> Queries the distance of the fourth peak to a limit line, and would return, e.g. 3.23
<b>Usage:</b>	Query only SCPI confirmed

**CALCulate<n>:PSEarch:PLIS<peak>:DETector?**  
**CALCulate<n>:PEAKsearch:PLIS<peak>:DETector**

This command queries the detector with which a peak was found in the peak search.



**Suffix:**  
 <n> irrelevant  
 <peak> [Peak](#)

**Return values:**  
 <Detector> String containing the name of the detector.

**Example:** `CALC:PEAK:PLIS4:DET?`  
 Queries the detector that the fourth peak was measured with, and would return, e.g. 'Average'

**Usage:** SCPI confirmed

**CALCulate<n>:PSEarch:PLISt<peak>:FREQUency?**  
**CALCulate<n>:PEAKsearch:PLISt<peak>:FREQUency?**

This command queries the frequency of a peak found in the peak search.

**Suffix:**  
 <n> irrelevant  
 <peak> [Peak](#)

**Return values:**  
 <Frequency> <numeric value>

**Example:** `CALC:PEAK:PLIS4:FREQ?`  
 Queries the frequency of the fourth peak, and would return, e.g. 69420000

**Usage:** Query only  
 SCPI confirmed

**CALCulate<n>:PSEarch:PLISt<peak>:LEVEl?**  
**CALCulate<n>:PEAKsearch:PLISt<peak>:LEVEl?**

This command queries the level of a peak found in the peak search.

**Suffix:**  
 <n> irrelevant  
 <peak> [Peak](#)

**Query parameters:**  
 <Level> <numeric value>

**Example:** //Query level of the fourth peak  
`CALC:PEAK:PLIS4:LEV?`  
 -53.99

**Usage:** Query only  
 SCPI confirmed

**CALCulate<n>:PSEarch:PLISt<peak>:SIZE?****CALCulate<n>:PEAKsearch:PLISt<peak>:SIZE?**

This command queries the number of peaks found in the peak search.

**Suffix:**

<n> irrelevant

<peak> irrelevant

**Return values:**

<Peaks>

**Example:**

CALC:PEAK:PLIS:SIZE

would return, e.g.

100

**Usage:**

Query only

SCPI confirmed

**CALCulate<n>:PSEarch:PLISt<peak>:TRACe?****CALCulate<n>:PEAKsearch:PLISt<peak>:TRACe?**

This command queries the trace that a peak found in the peak search is located on.

**Suffix:**

<n> irrelevant

<peak> [Peak](#)

**Return values:**

<Trace> String containing the number of the trace.

**Example:**

CALC:PEAK:PLIS4:TRAC

Queries the trace that the fourth peak is on, and would return, e.g.

'TRACE1'

**Usage:**

Query only

SCPI confirmed

**CALCulate<n>:PSEarch:PLISt<peak>[:DATA]?****CALCulate<n>:PEAKsearch:PLISt<peak>[:DATA]?**

This command queries the information for a peak found in the peak search.

**Suffix:**

<n> irrelevant

<peak> [Peak](#)

**Return values:**

<PeakResults> List of values for the selected peak.  
 The command returns the following information.  
 <TraceNumber>, <Detector>, <Frequency>, <Level>,  
 <DeltaLimit>, <Comment>, ...  
 <DeltaLimit> is '0' if you use no limit line.  
 <comment> is empty if you have not entered one for the corresponding peak.

**Example:**

```
CALC:PEAK:PLIS4?
Queries the information for the fourth peak, and would return,
e.g.
'TRACE2,Average,4.5e+07,53.07,0,Woohoo'
```

**Usage:**

Query only  
 SCPI confirmed

### 13.5.9 Final Measurement (and Trace) Configuration

CALCulate<n>:FMEasurement[:AUTO].....	460
[SENSe:]CORRection:TRANsducer:VIEW.....	460
[SENSe:]DETEctor<t>:FMEasurement.....	461
[SENSe:]FMEasurement:AUTO.....	462
[SENSe:]FMEasurement:TIME.....	462
DISPlay[:WINDow<n>]:TRACe<t>:MODE.....	462
DISPlay[:WINDow<n>]:TRACe<t>[:STATe].....	463

**CALCulate<n>:FMEasurement[:AUTO] <State>**

This command turns an automatic final measurement on and off.

When you turn on this feature, the R&S ESW performs a full automated test sequence, including a scan, a peak search and a final measurement.

**Suffix:**

<n> irrelevant

**Parameters:**

<State> ON | OFF  
 \*RST: OFF  
 Default unit: OFF

**Example:**

```
CALC:FME ON
Includes the final measurement in the test sequence.
```

**Usage:**

SCPI confirmed

**[SENSe:]CORRection:TRANsducer:VIEW <State>**

This command turns the "Transducer" trace mode on and off.

Also possible with `DISPlay[:WINDow<n>]:TRACe<t>:MODE` on page 462.

**Parameters:**

&lt;State&gt;

**ON | 1**

Turns on the transducer trace.

The transducer trace represents the correction values of all active transducers over the currently selected frequency range. When you turn on the transducer trace, all other traces are temporarily removed.

**OFF | 0**

Turns off the transducer trace, and restores the original scan traces.

**\*RST:** 0**Example:**

CORR:TRAN:VIEW ON

TRAC? TRACE1

Turns on the transducer trace and queries the correction values.

**Manual operation:** See "[Trace Mode](#)" on page 126**[SENSe:]DETEctor<t>:FMEasurement <Detector>**

This command selects the detector for the final measurement.

**Suffix:**

&lt;t&gt;

[Trace](#)**Parameters:**

&lt;Detector&gt;

**AVERage**

Selects the Average detector.

**CAVerage**

Selects the CISPR Average detector.

**CRMS**

Selects the CISPR RMS detector.

**NEGative**

Selects the Min Peak detector.

**NONE**

Ignores the corresponding trace during the final measurement.

**POSitive**

Selects the Max Peak detector.

**QPEak**

Selects the Quasipeak detector.

**RMS**

Selects the RMS detector.

**\*RST:** QPEak**Example:**

//Select final measurement detector

DET:FME POS

**Manual operation:** See "[Detector](#)" on page 127

**[SENSe:]FMEasurement:AUTO <State>**

This command turns automatic final measurements on and off.

When you turn on this feature, the R&S ESW performs a scan, a peak search and a final measurement in an automated test sequence.

**Parameters:**

<State> ON | OFF | 1 | 0  
\*RST: ON

**Example:** //Turn on final measurement  
FME:AUTO ON

**Manual operation:** See "[Interactive](#)" on page 128

**[SENSe:]FMEasurement:TIME <Time>**

This command defines the time each frequency in the peak list is measured during the final measurement.

**Parameters:**

<Time> <numeric value>  
Range: 0.00005 to 100  
\*RST: 1 s  
Default unit: s

**Example:** //Define measurement time  
FME:TIME 1us

**Manual operation:** See "[Measurement Time](#)" on page 95

**DISPlay[:WINDow<n>]:TRACe<t>:MODE <TraceMode>**

This command selects the trace mode.

To turn on the transducer trace mode, use [\[SENSe:\]CORRection:TRANsducer:VIEW](#) on page 460.

**Suffix:**

<n> irrelevant  
<t> 1..6  
[Trace](#)

**Parameters:**

&lt;DisplayMode&gt;

**AVERage**

Draws a trace based on the average over several measurements.

You can define the number of measurements considered in the averaging process with `[SENSe:]SWEep:COUNT`.

Unavailable in Receiver mode.

**BLANk**

Removes the trace from the display.

**MAXHold**

Draws a trace based on the highest values that have been measured over several measurements.

You can define the number of measurements with `[SENSe:]SWEep:COUNT`.

**MINHold**

Draws a trace based on the lowest values that have been measured over several measurements.

You can define the number of measurements with `[SENSe:]SWEep:COUNT`.

**TRD**

Draws a trace that shows the correction values of all active transducer factors in the currently selected frequency range.

See also `[SENSe:]CORRection:TRANsducer:VIEW` on page 460.

**VIEW**

Freezes the trace.

Even if you continue the measurement, the trace remains as it is.

**WRITe**

Overwrites the trace when a new measurement begins.

\*RST: Depends on the trace number.

**Example:**

```
DISP:TRAC2:MODE MAXH
SENS:SWE:COUNT 5
```

Selects the Max Hold trace mode and displays the highest value obtained over 5 measurements.

**Manual operation:** See "Trace Mode" on page 126

**DISPlay[:WINDow<n>]:TRACe<t>[:STATe] <State>**

This command turns a trace on and off.

The measurement continues in the background.

**Suffix:**

&lt;n&gt;

Window

Irrelevant in the Receiver application.

&lt;t&gt;

Trace

**Example:**                   DISP:TRAC3 ON

### 13.5.10 Final Results

CALCulate<n>:FMEasurement:PLISt<peak>:ALL?	464
CALCulate<n>:FMEasurement:PLISt<peak>:COMMeNt	464
CALCulate<n>:FMEasurement:PLISt<peak>:DELTA?	465
CALCulate<n>:FMEasurement:PLISt<peak>:DETEctor	465
CALCulate<n>:FMEasurement:PLISt<peak>:FREQuency?	466
CALCulate<n>:FMEasurement:PLISt<peak>:LEVel?	466
CALCulate<n>:FMEasurement:PLISt<peak>:SIze?	466
CALCulate<n>:FMEasurement:PLISt<peak>:TRACe?	467
CALCulate<n>:FMEasurement:PLISt<peak>[:DATA]?	467

---

#### CALCulate<n>:FMEasurement:PLISt<peak>:ALL?

This command queries the information for all peaks measured in the final measurement.

#### Suffix:

<n>                           irrelevant  
 <peak>                       irrelevant

#### Return values:

<FinalResults>           List of values representing all measured peaks. The size of the list depends on the number of peaks measured in the final measurement.  
 For each peak, the command returns the following information.  
 <TraceNumber>, <Detector>, <Frequency>, <Level>, <DeltaLimit>, <Comment>, ...  
 <DeltaLimit> is '0' if you use no limit line.  
 <comment> is empty if you have not entered one for the corresponding peak.

#### Example:

```
CALC:FME:PLIS?
would return, e.g.
' TRACE1, Quasi-Peak,
4.5e+07, 53.99, 0, yahoo, TRACE2, Average,
4.5e+07, 53.07, 0, , TRACE3, RMS,
4.5e+07, 50.89, 0, , TRACE4, Quasi-Peak,
4.5e+07, 53.99, 0, , [...] '
```

#### Usage:

Query only  
 SCPI confirmed

---

#### CALCulate<n>:FMEasurement:PLISt<peak>:COMMeNt <Comment>

This command assigns a comment to a peak measured in the final measurement.

<b>Suffix:</b>	
<n>	irrelevant
<peak>	Peak
<b>Parameters:</b>	
<Comment>	String containing the comment.
<b>Example:</b>	CALC:FME:PLIS4:COMM 'Woohoo' Defines a comment for the fourth peak.
<b>Usage:</b>	SCPI confirmed

#### CALCulate<n>:FMEasurement:PLIS<peak>:DELTA?

This command queries the distance of a peak to the nearest limit line in the final measurement.

<b>Suffix:</b>	
<n>	irrelevant
<peak>	Peak
<b>Query parameters:</b>	
<Level>	<numeric value> If you are using no limit line, the return value is '0'.
<b>Example:</b>	CALC:FME:PLIS4:DELTA? Queries the distance of the fourth peak to a limit line, and would return, e.g. 3.23
<b>Usage:</b>	Query only SCPI confirmed

#### CALCulate<n>:FMEasurement:PLIS<peak>:DETECTOR

This command queries the detector with which a peak was measured in the final measurement.

<b>Suffix:</b>	
<n>	irrelevant
<peak>	Peak
<b>Return values:</b>	
<Detector>	String containing the name of the detector.
<b>Example:</b>	CALC:FME:PLIS4:DET? Queries the detector that the fourth peak was measured with, and would return, e.g. 'Average'
<b>Usage:</b>	SCPI confirmed



**CALCulate<n>:FMEasurement:PLIS<peak>:FREQuency?**

This command queries the frequency of a peak measured in the final measurement.

**Suffix:**

<n> irrelevant

<peak> [Peak](#)

**Return values:**

<Frequency> <numeric value>

**Example:**

`CALC:FME:PLIS4:FREQ?`

Queries the frequency of the fourth peak, and would return, e.g.  
69420000

**Usage:**

Query only  
SCPI confirmed

**CALCulate<n>:FMEasurement:PLIS<peak>:LEVel?**

This command queries the level of a peak measured in the final measurement.

**Suffix:**

<n> irrelevant

<peak> [Peak](#)

**Query parameters:**

<Level> <numeric value>

**Example:**

//Query level of the fourth peak

`CALC:FME:PLIS4:LEV?`

-53.99

**Usage:**

Query only  
SCPI confirmed

**CALCulate<n>:FMEasurement:PLIS<peak>:SIZE?**

This command queries the number of peaks measured in the final measurement.

**Suffix:**

<n> irrelevant

<peak> irrelevant

**Return values:**

<Peaks>

**Example:**

`CALC:FME:PLIS:SIZE`

would return, e.g.

100

**Usage:**

Query only  
SCPI confirmed

**CALCulate<n>:FMEasurement:PLIS<peak>:TRACe?**

This command queries the trace that a peak measured in the final measurement is located on.

**Suffix:**

<n> irrelevant

<peak> [Peak](#)

**Return values:**

<Trace> String containing the number of the trace.

**Example:**

CALC:FME:PLIS4:TRAC

Queries the trace that the fourth peak is on, and would return, e.g.

'TRACE1'

**Usage:**

Query only  
SCPI confirmed

**CALCulate<n>:FMEasurement:PLIS<peak>[:DATA]?**

This command queries the information for a peak measured in the final measurement.

**Suffix:**

<n> irrelevant

<peak> [Peak](#)

**Return values:**

<PeakResults>

List of values for the selected peak.

The command returns the following information.

<TraceNumber>, <Detector>, <Frequency>, <Level>, <DeltaLimit>, <Comment>, ...

<DeltaLimit> is '0' if you use no limit line.

<comment> is empty if you have not entered one for the corresponding peak.

**Example:**

CALC:FME:PLIS4?

Queries the information for the fourth peak, and would return, e.g.

'TRACE2,Average,4.5e+07,53.07,0,Woohoo'

**Usage:**

Query only  
SCPI confirmed

### 13.5.11 LISN Configuration

[SENSe:]FMEasurement:LISN:PHASe.....	468
[SENSe:]SCAN<sr>:LISN:PHASe.....	468
INPut<ip>:LISN:FILTer:HPASs[:STATe].....	469
INPut<ip>:LISN:PHASe.....	469
INPut<ip>:LISN[:TYPE].....	470

---

#### [SENSe:]FMEasurement:LISN:PHASe <Phase>, [<Phase>]

This command selects the LISN phases to be measured in a final measurement.

##### Parameters:

<Phase>, [<Phase>] You can select several phases for the final measurement:  
 <Phase>,[<Phase>,<Phase>,<Phase>]

**L1**

**L2**

Available for networks with four phases (R&S ESH2Z5, R&S ENV4200 and R&S ENV432)

**L3**

Available for networks with four phases (R&S ESH2Z5, R&S ENV4200 and R&S ENV432)

**N**

\*RST: L1

**Example:** Selects phases for the final measurement

```
FME:LISN:PHAS L1,N
```

**Manual operation:** See "Phase" on page 130

---

#### [SENSe:]SCAN<sr>:LISN:PHASe <Phase>, [<Phase>]

This command selects the LISN phases to be measured in a scan.

##### Suffix:

<sr> irrelevant

##### Parameters:

<Phase>, [<Phase>] You can select several phases for the scan:  
 <Phase>,[<Phase>,<Phase>,<Phase>]

**L1**

**L2**

Available for networks with four phases (R&S ESH2Z5, R&S ENV4200 and R&S ENV432)

**L3**

Available for networks with four phases (R&S ESH2Z5, R&S ENV4200 and R&S ENV432)

**N**

\*RST: L1

**Example:** //Select phases to be measured in the scan  
SCAN:LISN:PHAS L1,N

**Manual operation:** See "Phase" on page 130

**INPut<ip>:LISN:FILTeR:HPASs[:STATe] <State>**

This command turns the 150 kHz highpass filter of the ENV216 network on and off.

Prerequisites for this command

- Select ENV216 network (INPut<ip>:LISN[:TYPE]).

**Suffix:**

<ip> irrelevant

**Parameters:**

<State> ON | OFF | 1 | 0  
\*RST: OFF

**Example:** //Turn on high pass filter  
INP:LISN:TYPE ENV216  
INP:LISN:FILT:HPAS ON

**Manual operation:** See "High-Pass Filter 150 kHz" on page 131

**INPut<ip>:LISN:PHASe <Phase>**

This command selects one LISN phase to be measured.

The command is available in all applications (spectrum, receiver, I/Q analyzer and analog demodulator).

**Suffix:**

<ip> irrelevant

**Parameters:**

<Phase> **L1**  
**L2**  
Available for networks with four phases (R&S ESH2Z5, R&S ENV4200 and R&S ENV432)  
**L3**  
Available for networks with four phases (R&S ESH2Z5, R&S ENV4200 and R&S ENV432)  
**N**  
\*RST: L1

**Example:** //Select phase L1  
INP:LISN:PHAS L1

**Manual operation:** See "Phase" on page 130

**INPut<ip>:LISN[:TYPE] <Type>**

This command turns automatic control of a LISN on and off. It also selects the type of network.

**Suffix:**

<ip>                      irrelevant

**Parameters:**

<Type>

**ENV216**

R&S ENV 216: two phases and highpass are controllable.

**ENV432**

R&S ENV 432: four phases are controllable.

**ENV4200**

R&S ENV 4200: four phases are controllable.

**ESH2Z5**

R&S ESH2-Z5: four phases (incl. protective earth) are controllable.

**ESH3Z5**

R&S ESH3-Z5: two phases (incl. protective earth) are controllable.

**FOURphase**

R&S ESH2-Z5: four phases (incl. protective earth) are controllable.

**OFF**

Turns off control of the LISN.

**TWOPhase**

R&S ESH3-Z5: two phases (incl. protective earth) are controllable.

\*RST:              OFF

**Example:**

```
//Select LISN
INP:LISN:TYPE TWOP
```

**Manual operation:** See "[LISN Type](#)" on page 130

### 13.5.12 CISPR APD Measurement Configuration

The remote commands to configure CISPR APD measurements are similar to those available for the APD measurement in the Spectrum application.

For a comprehensive description, refer to the user manual of the Spectrum application.

[CALCulate<n>:MARKer<m>:Y:PERCent](#)..... 470

**CALCulate<n>:MARKer<m>:Y:PERCent <Probability>**

This command sets a marker to a particular probability value. You can query the corresponding level with [CALCulate<n>:MARKer<m>:X](#).

Using the command turns delta markers into normal markers.

This command is available for CCDF measurements.

**Suffix:**

<n> [Window](#)

<m> [Marker](#)

**Parameters:**

<Probability> Range: 0 % to 100 %

**Example:**

CALC1:MARK:Y:PERC 95PCT

Positions marker 1 to a probability of 95 %.

**Manual operation:** See "[Percent Marker](#)" on page 134

### 13.5.13 Programming Example: Performing a Sequence of Measurements

This example demonstrates how to perform several measurements in a sequence in a remote environment.

```
//2xSpectrumAnalyzer + 2xIQ, start Sequencer at the end, test OPC?
// -----

//-----Preparing the instrument and first channel -----
*RST
//Activate new IQ channel
INSTrument:CREate:NEW IQ,'IQ 1'
//Set sweep count for new IQ channel
SENS:SWEEP:COUNT 6
//Change trace modes for IQ channel
DISP:TRAC1:MODE BLANK
DISP:TRAC2:MODE MAXH
DISP:TRAC3:MODE MINH
//Switch to single sweep mode
INIT:CONT OFF
//switch back to first (default) analyzer channel
INST:SEL 'Spectrum';*WAI
//Switch into SEM
SENSe:SWEEP:MODE ESpectrum
//Load Sem standard file for W-CDMA
SENSe:ESpectrum:PRESet:STANdard 'WCDMA\3GPP\DL\3GPP_DL.xml'
//Set sweep count in Spectrum channel
SENS:SWEEP:COUNT 5

//-----Creating a second measurement channel -----

//Create second IQ channel
INSTrument:CREate:NEW IQ,'IQ 2'
```

```

//Set sweep count
SENS:SWEEP:COUNT 2
//Change trace modes
DISP:TRAC1:MODE MAXH
DISP:TRAC2:MODE MINH
//Create new analyzer channel
INSTrument:CREate:NEW SANalyzer,'Spectrum 2'
//Activate ACLR measurement in channel 'Spectrum 2'
CALCulate:MARKer:FUNCTion:POWer:SElect ACPower
//Load W-CDMA Standard
CALCulate:MARKer:FUNCTion:POWer:PRESet FW3Gppcdma
//Change trace modes
DISP:TRAC2:MODE MAXH
DISP:TRAC1:MODE MINH

//-----Performing a sweep and retrieving results-----

//Change sweep count
SENS:SWEEp:COUNT 7
//Single Sweep mode
INIT:CONT OFF
//Switch back to first IQ channel
INST:SEL 'IQ 1';*WAI
//Perform a measurement
INIT:IMM;*OPC?
//Retrieve results
CALC:MARK:Y?
//Activate Multiview
DISPlay:ATAB ON

//-----Performing a sequence of measurements with the Sequencer-----
//Activate Sequencer
SYSTem:SEQuencer ON
//Start sweep in Sequencer
INITiate:SEQuencer:IMMediate;*OPC?
//Switch into first IQ channel to get results
INST:SEL 'IQ 1';*WAI
CALCulate:MARKer:MAXimum
CALC:MARK:Y?
//Change sweep time in IQ
SENS:SWE:TIME 300us
//Switch to single Sequencer mode
INITiate:SEQuencer:MODE SINGLE
//Sweep all channels once, taking the sweep count in each channel into account
INITiate:SEQuencer:IMMediate;*OPC?
//Set marker to maximum in IQ1 and query result
CALCulate:MARKer:MAXimum
CALC:MARK:Y?
//Switch to second IQ channel and retrieve results
INST:SEL 'IQ 2';*WAI

```

```

CALCulate:MARKer:MIN
CALC:MARK:Y?
//Switch to first Spectrum channel
INST:SEL 'Spectrum';*WAI
//Query one of the SEM results
CALCulate:MARKer:FUNCTion:POWer:RESult? CPOWer
//Switch to second Spectrum channel
INST:SEL 'Spectrum 2';*WAI
//Query channel power result
CALCulate:MARKer:FUNCTion:POWer:RESult? ACPoWer

```

## 13.6 Configuration

• <a href="#">Input Configuration</a> .....	473
• <a href="#">Output Configuration</a> .....	483
• <a href="#">Frequency Configuration</a> .....	491
• <a href="#">Amplitude Configuration</a> .....	493
• <a href="#">Diagram Scale</a> .....	497
• <a href="#">Bandwidth and Filter Configuration</a> .....	497
• <a href="#">Trigger Configuration</a> .....	499

### 13.6.1 Input Configuration

• <a href="#">RF Input Configuration</a> .....	473
• <a href="#">Preselector Configuration</a> .....	475
• <a href="#">External Generator Control (Optional)</a> .....	476
• <a href="#">User Port Configuration (AUX Port)</a> .....	481

#### 13.6.1.1 RF Input Configuration

<a href="#">INPut&lt;ip&gt;:COUPling</a> .....	473
<a href="#">INPut&lt;ip&gt;:IMPedance</a> .....	474
<a href="#">INPut&lt;ip&gt;:TYPE</a> .....	474

---

#### INPut<ip>:COUPling <CouplingType>

This command selects the coupling type of the RF input.

#### Suffix:

<ip>	1   2
	irrelevant



**Parameters:**

<CouplingType> AC | DC  
**AC**  
 AC coupling  
**DC**  
 DC coupling  
 \*RST: AC

**Example:** INP:COUP DC

**Manual operation:** See " [Input Coupling](#) " on page 142

**INPut<ip>:IMPedance <Impedance>**

This command selects the nominal input impedance of the RF input. In some applications, only 50 Ω are supported.

**Suffix:**

<ip> 1 | 2  
 irrelevant

**Parameters:**

<Impedance> 50 | 75  
 \*RST: 50 Ω  
 Default unit: OHM

**Example:** INP:IMP 75

**Manual operation:** See " [Impedance](#) " on page 142

**INPut<ip>:TYPE <Input>**

The command selects the input path.

**Suffix:**

<ip> 1 | 2  
 irrelevant

**Parameters:**

<Input> **INPUT1**  
 Selects RF input 1.  
**INPUT2**  
 Selects RF input 2.  
 \*RST: INPUT1

**Example:** //Select input path  
 INP:TYPE INPUT1

**Manual operation:** See " [Input Selection](#) " on page 117

### 13.6.1.2 Preselector Configuration

INPut<ip>:ATTenuation:LIMiter[:STATe].....	475
INPut<ip>:PRESElection:FILTer:NOTCh<filter>[:STATe].....	475
INPut<ip>:PRESElection:FILTer:SPLit[:STATe].....	476
INPut<ip>:PRESElection[:STATe].....	476

---

#### INPut<ip>:ATTenuation:LIMiter[:STATe] <State>

This command turns the pulse limiter on and off.

The pulse limiter is an additional protection mechanism for the second RF input that attenuates high level pulses.

##### Suffix:

<ip>                    irrelevant

##### Parameters:

<State>                ON | OFF  
 \*RST:                 ON

**Example:**            //Turn on pulse limiter  
 INP:ATT:LIM ON

**Usage:**                SCPI confirmed

**Manual operation:** See "Pulse Limiter" on page 142

---

#### INPut<ip>:PRESElection:FILTer:NOTCh<filter>[:STATe] <State>

This command turns a preselecting notch filter on and off.

##### Suffix:

<ip>                    irrelevant

<filter>                1..2  
 Selects the filter.  
 • <1> Selects the notch filter suppressing signals from 2.4 GHz to 2.5 GHz.  
 • <2> Selects the notch filter suppressing signals from 2.725 GHz to 2.875 GHz.

##### Parameters:

<State>                ON | OFF  
 \*RST:                 OFF

**Example:**            //Turn on notch filter for frequencies from 2.725 GHz to 2.875 GHz.  
 INP:PRE:FILT:NOTC2 ON

**Usage:**                SCPI confirmed

**Manual operation:** See "Preselector Filter Settings" on page 143

**INPut<ip>:PRESelection:FILTer:SPLit[:STATe] <Filter>**

This command turns the two stage preselector filter in the frequency range from 150 kHz to 30 MHz on and off.

**Suffix:**

<ip> irrelevant

**Parameters:**

<Filter>

**ON**

Two consecutive filters are applied in the frequency range from 150 kHz to 30 MHz: one from 150 kHz to 2 MHz, and one from 2 MHz to 30 MHz.

**OFF**

A single filter is applied, covering the frequency range from 150 kHz to 30 MHz.

\*RST: OFF

**Example:**

```
//Apply 2 filter stages
INP:PRE:FILT:SPL ON
```

**Usage:**

SCPI confirmed

**Manual operation:** See "[Preselector Filter Settings](#)" on page 143

**INPut<ip>:PRESelection[:STATe] <State>**

This command turns the preselector on and off.

**Parameters:**

<State>

ON | OFF | 1 | 0

\*RST: Depends on application.

**Manual operation:** See "[Preselector State](#)" on page 143

**13.6.1.3 External Generator Control (Optional)**

SOURce:EXTernal:FREQUency.....	477
SOURce:EXTernal:FREQUency:COUPling[:STATe].....	477
SOURce:EXTernal:FREQUency[:FACTor]:DENominator.....	477
SOURce:EXTernal:FREQUency[:FACTor]:NUMerator.....	478
SOURce:EXTernal:FREQUency:OFFSet.....	478
SOURce:EXTernal:POWer[:LEVel].....	479
SOURce:EXTernal:ROSCillator[:SOURce].....	479
SOURce:EXTernal[:STATe].....	479
SOURce:POWer[:LEVel][:IMMEDIATE]:OFFSet.....	479
SYSTem:COMMunicate:GPIB:RDEvice:GENerator:ADDRes.....	480
SYSTem:COMMunicate:RDEvice:GENerator:INTerface.....	480
SYSTem:COMMunicate:RDEvice:GENerator:LINK.....	480
SYSTem:COMMunicate:RDEvice:GENerator:TYPE.....	481
SYSTem:COMMunicate:TCPIP:RDEvice:GENerator:ADDRes.....	481

**SOURce:EXternal:FREQUENCY** <Frequency>

This command defines a fixed source frequency for the external generator.

**Parameters:**

<Frequency> Source frequency of the external generator.  
\*RST: 1100050000

**Example:**

```
//Define frequency of the generator
SOUR:EXT:FREQ 10MHz
```

**Manual operation:** See "[\(Manual\) Source Frequency](#)" on page 155

**SOURce:EXternal:FREQUENCY:COUPling[:STATe]** <State>

This command couples the frequency of the external generator output to the R&S ESW.

**Parameters:**

<State> ON | OFF | 0 | 1

**ON | 1**

Default setting: a series of frequencies is defined (one for each sweep point), based on the current frequency at the RF input of the R&S ESW; the RF frequency range covers the currently defined span of the R&S ESW (unless limited by the range of the signal generator)

**OFF | 0**

The generator uses a single fixed frequency, defined by [SOURce:EXternal:FREQUENCY](#).

\*RST: 1

**Example:**

```
SOUR:EXT:FREQ:COUP ON
```

**Manual operation:** See "[Source Frequency Coupling](#)" on page 155

**SOURce:EXternal:FREQUENCY[:FACTor]:DENominator** <Value>

This command defines the denominator of the factor with which the analyzer frequency is multiplied in order to obtain the transmit frequency of the selected generator.

Select the multiplication factor such that the frequency range of the generator is not exceeded if the following formula is applied to the start and stop frequency of the analyzer:

$$F_{Generator} = \left| F_{Analyzer} * \frac{Numerator}{Denominator} + F_{Offset} \right|$$

**Parameters:**

<Value> <numeric value>  
\*RST: 1

**Example:** //Define multiplication factor of 4/3; the transmit frequency of the generator is 4/3 times the analyzer frequency  
 SOUR:EXT:FREQ:NUM 4  
 SOUR:EXT:FREQ:DEN 3

**Manual operation:** See "(Automatic) Source Frequency (Numerator/Denominator/Offset)" on page 155

#### **SOURce:EXTernal:FREQUENCY[:FACTor]:NUMerator** <Value>

This command defines the numerator of the factor with which the analyzer frequency is multiplied in order to obtain the transmit frequency of the selected generator.

Select the multiplication factor such that the frequency range of the generator is not exceeded if the following formula is applied to the start and stop frequency of the analyzer:

$$F_{Generator} = \left| F_{Analyzer} * \frac{Numerator}{Denominator} + F_{Offset} \right|$$

#### **Parameters:**

<Value> <numeric value>  
 \*RST: 1

**Example:** //Define multiplication factor of 4/3; the transmit frequency of the generator is 4/3 times the analyzer frequency  
 SOUR:EXT:FREQ:NUM 4  
 SOUR:EXT:FREQ:DEN 3

**Manual operation:** See "(Automatic) Source Frequency (Numerator/Denominator/Offset)" on page 155

#### **SOURce:EXTernal:FREQUENCY:OFFSet** <Offset>

This command defines the frequency offset of the generator with reference to the analyzer frequency.

Select the offset such that the frequency range of the generator is not exceeded if the following formula is applied to the start and stop frequency of the analyzer:

$$F_{Generator} = \left| F_{Analyzer} * \frac{Numerator}{Denominator} + F_{Offset} \right|$$

#### **Parameters:**

<Offset> <numeric value>, specified in Hz, kHz, MHz or GHz, rounded to the nearest Hz  
 \*RST: 0 Hz

**Example:** //Define an offset between generator output frequency and analyzer frequency  
 SOUR:EXT:FREQ:OFFS 10HZ

**Manual operation:** See "(Automatic) Source Frequency (Numerator/Denominator/Offset)" on page 155

#### **SOURce:EXTernal:POWer[:LEVel]** <Level>

This command sets the output power of the selected generator.

**Parameters:**

<Level>                    <numeric value>  
 \*RST:                    -20 dBm

**Example:**                //Define generator output level  
 SOUR:EXT:POW -30dBm

**Manual operation:** See " [Source Power](#) " on page 154

#### **SOURce:EXTernal:ROSCillator[:SOURce]** <Source>

This command controls selection of the reference oscillator for the external generator.

If the external reference oscillator is selected, the reference signal must be connected to the rear panel of the instrument.

**Parameters:**

<Source>                    **INTernal**  
 Uses the internal reference.

**EXTernal**  
 Uses the external reference; if none is available, an error flag is displayed in the status bar.

\*RST:                    INT

**Example:**                //Select an external reference oscillator  
 SOUR:EXT:ROSC EXT

**Manual operation:** See " [Reference](#) " on page 153

#### **SOURce:EXTernal[:STATe]** <State>

This command activates or deactivates the connected external generator.

**Parameters:**

<State>                    ON | OFF | 1 | 0  
 \*RST:                    0

**Manual operation:** See " [Source State](#) " on page 154

#### **SOURce:POWer[:LEVel][:IMMediate]:OFFSet** <Offset>

This command defines a level offset for the external generator level. Thus, for example, attenuators or amplifiers at the output of the external generator can be taken into account for the setting.

**Parameters:**

<Offset>                    Range:        -200 dB to +200 dB  
                                  \*RST:        0dB

**Example:**                    //Define a level offset on the external generator  
                                  SOUR:POW:OFFS -10dB

**Manual operation:**    See " [Source Offset](#) " on page 155

**SYSTem:COMMunicate:GPIB:RDEvice:GENerator:ADDRes <Number>**

Changes the IEC/IEEE-bus address of the external generator.

**Parameters:**

<Number>                    Range:        0 to 30  
                                  \*RST:        28

**Example:**                    SYST:COMM:GPIB:RDEV:GEN:ADDR 15

**Manual operation:**    See " [GPIB Address / TCPIP Address / Computer Name](#) " on page 153

**SYSTem:COMMunicate:RDEvice:GENerator:INTerface <Type>**

Defines the interface used for the connection to the external generator.

This command is only available if external generator control is active (see [SOURCE:EXTernal\[:STATe\]](#) on page 479).

**Parameters:**

<Type>                        GPIB | TCPip  
                                  \*RST:        GPIB

**Example:**                    SYST:COMM:RDEV:GEN:INT TCP

**Manual operation:**    See " [Interface](#) " on page 153

**SYSTem:COMMunicate:RDEvice:GENerator:LINK <Type>**

This command selects the link type of the external generator if the GPIB interface is used.

The difference between the two GPIB operating modes is the execution speed. While, during GPIB operation, each frequency to be set is transmitted to the generator separately, a whole frequency list can be programmed in one go if the TTL interface is also used. Frequency switching can then be performed per TTL handshake which results in considerable speed advantages.

This command is only available if external generator control is active (see [SOURCE:EXTernal\[:STATe\]](#) on page 479).

**Parameters:**

<Type> GPIB | TTL

**GPIB**  
GPIB connection without TTL synchronization (for all generators of other manufacturers and some Rohde & Schwarz devices)

**TTL**  
GPIB connection with TTL synchronization (if available; for most Rohde&Schwarz devices)

\*RST: GPIB

**Example:**

```
SYST:COMM:RDEV:GEN:LINK TTL
```

Selects GPIB + TTL interface for generator operation.

**Manual operation:** See "[TTL Handshake](#)" on page 153

**SYSTem:COMMunicate:RDEvice:GENerator:TYPE <Type>**

This command selects the type of external generator.

For a list of the available generator types see "[Overview of Supported Generators](#)" on page 147.

**Parameters:**

<Name> <Generator name as string value>

\*RST: SMU02

**Example:**

```
//Select an external generator
SYST:COMM:RDEV:GEN:TYPE 'SMW06'
```

**Manual operation:** See "[Generator Type](#)" on page 153

**SYSTem:COMMunicate:TCPip:RDEvice:GENerator:ADDRess <Address>**

Configures the TCP/IP address for the external generator.

**Parameters:**

<Address> TCP/IP address between 0.0.0.0 and 0.255.255.255

\*RST: 0.0.0.0

**Example:**

```
SYST:COMM:TCP:RDEV:GEN:ADDR 130.094.122.195
```

**Manual operation:** See "[GPIB Address / TCPIP Address / Computer Name](#)" on page 153

**13.6.1.4 User Port Configuration (AUX Port)**

INPut<ip>:UPORt:STATe.....	482
INPut<ip>:UPORt[:VALue].....	482
OUTPut:UPORt[:VALue].....	482
OUTPut:UPORt:STATe.....	483



**INPut<ip>:UPORt:STATe <State>**

This command toggles the control lines of the user ports for the **AUX PORT** connector. This 9-pole SUB-D male connector is located on the rear panel of the R&S ESW.

See the R&S ESW Getting Started manual for details.

**Suffix:**

<ip>                    1 | 2  
                          irrelevant

**Parameters:**

<State>                **ON | 1**  
                          User port is switched to INPut  
                          **OFF | 0**  
                          User port is switched to OUTPut  
\*RST:                 1

**INPut<ip>:UPORt[:VALue]**

This command queries the control lines of the user ports.

For details see [OUTPut:UPORt\[:VALue\]](#) on page 482.

**Suffix:**

<ip>                    1 | 2  
                          irrelevant

**Example:**

```
INP:UPOR?
//Result: #B00100100
Pins 5 and 7 are active.
```

**OUTPut:UPORt[:VALue] <Value>**

This command sets the control lines of the user ports.

The assignment of the pin numbers to the bits is as follows:

Bit	7	6	5	4	3	2	1	0
Pin	N/A	N/A	5	3	4	7	6	2

Bits 7 and 6 are not assigned to pins and must always be 0.

The user port is written to with the given binary pattern. If the user port is programmed to input instead of output (see [INPut<ip>:UPORt:STATe](#) on page 482), the output value is temporarily stored.

**Parameters:**

<Value>                bit values in hexadecimal format  
                          TTL type voltage levels (max. 5V)  
Range:                 #B00000000 to #B00111111

**Example:**            `OUTP:UPOR #B00100100`  
                       Sets pins 5 and 7 to 5 V.

---

### **OUTPut:UPORt:STATe <State>**

This command toggles the control lines of the user ports for the **AUX PORT** connector. This 9-pole SUB-D male connector is located on the rear panel of the R&S ESW.

#### **Parameters:**

<State>                **ON | 1**  
                           User port is switched to OUTPut

**OFF | 0**  
                           User port is switched to INPut

\*RST:                 0

## **13.6.2 Output Configuration**

- [IF / Video / Demodulation](#).....483
- [Additional Output](#).....488

### **13.6.2.1 IF / Video / Demodulation**

<a href="#">OUTPut&lt;i&gt;:IF:AUDio</a> .....	483
<a href="#">OUTPut&lt;i&gt;:IF:COUPling</a> .....	484
<a href="#">OUTPut&lt;i&gt;:IF:IFFrequency</a> .....	484
<a href="#">OUTPut&lt;i&gt;:IF:LPASs:FREQuency:MANual</a> .....	484
<a href="#">OUTPut&lt;i&gt;:IF:LPASs[:STATe]</a> .....	485
<a href="#">OUTPut&lt;i&gt;:IF:SCALe</a> .....	485
<a href="#">OUTPut&lt;i&gt;:IF[:SOURce]</a> .....	486
<a href="#">OUTPut&lt;i&gt;:LINK</a> .....	486
<a href="#">[SENSe:]DEMod:SQUelch:LEVel</a> .....	487
<a href="#">[SENSe:]DEMod:SQUelch[:STATe]</a> .....	487
<a href="#">SYSTem:SPEaker:MAXVolume</a> .....	487
<a href="#">SYSTem:SPEaker:MUTE</a> .....	488
<a href="#">SYSTem:SPEaker:VOLume</a> .....	488

---

### **OUTPut<i>:IF:AUDio <State>**

This command turns additional signal output on the headphone jack on and off.

Available for Output 1 and Output 2.

#### **Suffix:**

<i>                      irrelevant

#### **Parameters:**

<State>                ON | OFF

**Example:**            `OUTP:IF:AUD ON`  
                           Turns on the audio output.

**Manual operation:** See ["Phones"](#) on page 159

---

### **OUTPut<i>:IF:COUPling** <Coupling>

This command selects the output coupling type.

Available for the following output types:

- Video
- FM

**Suffix:**

<i> [Output](#)

**Parameters:**

<Coupling>      **AC**  
 AC coupling: rejects the DC component of the signal.

**DC**  
 DC coupling: transfers the complete signal.

**Example:**            `OUTP2:IF:COUP AC`  
 Selects AC coupling for output 2.

**Manual operation:** See ["Coupling"](#) on page 158

---

### **OUTPut<i>:IF:IFFrequency** <Frequency>

This command defines the frequency of the IF signal that is output.

Available for output of the IF signal.

**Suffix:**

<i> [Output](#)

**Parameters:**

<Frequency>      Numeric value in Hz.

**Example:**            `OUTP:IF IF`  
                           `OUTP:IF:IFFR 100MHZ`  
 Outputs the IF signal with a frequency of 100 MHz.

**Manual operation:** See ["IF Output Frequency"](#) on page 158

---

### **OUTPut<i>:IF:LPASs:FREQuency:MANual** <Frequency>

This command defines the cutoff frequency of the low pass filter available for signal output.

Available for the following output types:

- Video
- AM
- FM
- PM

This command is available after you have turned on the low pass filter with `OUTPut<i>:IF:LPASs[:STATe]`.

**Suffix:**

<i> [Output](#)

**Parameters:**

<Frequency> Numeric value in Hz.

**Example:**

```
OUTP:IF:LPAS ON
OUTP:IF:LPAS:FREQ:MAN 100KHZ
```

Turns on the low pass filter with a cutoff frequency of 100 kHz.

**Manual operation:** See "[Low Pass](#)" on page 158

**OUTPut<i>:IF:LPASs[:STATe] <State>**

This command turns a low pass filter to control the output on and off.

Available for the following output types:

- Video
- AM
- FM
- PM

**Suffix:**

<i> [Output](#)

**Parameters:**

<State> ON | OFF

**Example:**

```
OUTP:IF:LPAS ON
OUTP:IF:LPAS:FREQ:MAN 100KHZ
```

Turns on the low pass filter with a cutoff frequency of 100 kHz.

**Manual operation:** See "[Low Pass](#)" on page 158

**OUTPut<i>:IF:SCALE <Scale>**

This command defines the scale of the transferred signal.

Available for the following output types:

- AM
- FM

**Suffix:**

<i> [Output](#)

**Parameters:**

<Scale> Numeric value whose unit depends on the output type:

- % for AM output
- Hz for FM output

**Example:**            `OUTP:IF FM`  
                   `OUTP:IF:SCAL 100KHZ`  
 Selects a scale of 100 kHz for FM output on Output 1.

**Manual operation:** See ["Scale"](#) on page 159

### **OUTPut<i>:IF[:SOURce] <Type>**

This command selects the type of signal data that is output.

**Suffix:**

<i>                    [Output](#)

**Parameters:**

<Type>

**AM**  
Outputs the AM signal.

**FM**  
Outputs the FM signal.

**FOCus**  
Outputs the data of the currently selected measurement window.  
Available for analog demodulation.

**IF**  
Outputs the IF signal.  
Unavailable for audio output.

**OFF**  
Turns off the output.

**VIDeo**  
Outputs the video signal.  
Unavailable for audio output.

**Example:**            `OUTP:IF:SOUR AM`  
 Selects the output of the AM signal data.

**Manual operation:** See ["Selecting the output type"](#) on page 157

### **OUTPut<i>:LINK <Scope>**

This command selects the scope of the output settings.

**Suffix:**

<i>                    irrelevant

**Parameters:**

<Scope>

**ON**  
Output settings apply to the current measurement channel.

**OFF**  
Output settings apply to all measurement channels.

**Example:**            `OUTP:LINK OFF`  
 Output configuration applies to all measurement channels.

**Manual operation:** See ["Output Coupling"](#) on page 157

**[SENSe:]DEMod:SQUelch:LEVel** <Level>

This command defines the squelch level for audio output, below which the output is not demodulated.

If you are using the "Marker Demodulation" marker function in the spectrum application, the command instead selects the level below which the signal at the marker position is not demodulated.

**Parameters:**

<Level>                    <numeric value>  
                               Default unit: PCT

**Example:**                //Configure squelch for audio output  
                               DEM:SQU ON  
                               DEM:SQU:LEV 10

**Usage:**                    SCPI confirmed

**Manual operation:**    See "[Squelch](#)" on page 159

**[SENSe:]DEMod:SQUelch[:STATe]** <State>

This command turns a squelch for the audio output on and off.

The squelch is available for the following outputs.

- AM
- FM

If you are using the "Marker Demodulation" marker function in the spectrum application, the command instead turns selective demodulation at the marker position on and off. For selective demodulation, the R&S ESW turns on a video trigger whose level corresponds to the squelch level. Therefore it turns off other triggers or gates.

In both cases, you can define the squelch level with [\[SENSe:\]DEMod:SQUelch:LEVel](#).

**Parameters:**

<State>                    ON | OFF | 1 | 0  
                               \*RST:            OFF

**Example:**                //Configure squelch for audio output  
                               DEM:SQU ON  
                               DEM:SQU:LEV 10

**Usage:**                    SCPI confirmed

**Manual operation:**    See "[Squelch](#)" on page 159

**SYSTem:SPEaker:MAXVolume** <Volume>

This command defines the maximum volume level for audio output (for example over headphones).

**Parameters:**

<Volume> Numeric value between 0 and 1, with 1 being the loudest.

**Example:**

SYST:SPE:MAXV 0.6

Defines a maximum level of 60 %.

**Manual operation:** See "Controlling the volume" on page 159

**SYSTem:SPEaker:MUTe**

This command turns audio output off.

To turn the volume back on again, use `SYSTem:SPEaker:VOLume`.

**Usage:** Event

**Manual operation:** See "Controlling the volume" on page 159

**SYSTem:SPEaker:VOLume <Volume>**

This command defines the volume with which audio signals are output.

**Parameters:**

<Volume> numeric value  
 Numeric value between 0 and 1, with 1 being the loudest.  
 Note that if you have defined a maximum volume level with `SYSTem:SPEaker:MAXVolume`, the value range is limited by the maximum volume.

**Example:**

SYST:SPE:VOL 0.25

Defines a volume of 25 %.

**Manual operation:** See "Controlling the volume" on page 159

**13.6.2.2 Additional Output**

<code>OUTPut:PROBe&lt;probe&gt;[:POWER]</code> .....	488
<code>OUTPut:TRIGger&lt;port&gt;:DIRection</code> .....	489
<code>OUTPut:TRIGger&lt;port&gt;:LEVel</code> .....	489
<code>OUTPut:TRIGger&lt;port&gt;:OTYPe</code> .....	489
<code>OUTPut:TRIGger&lt;port&gt;:PULSe:IMMediate</code> .....	490
<code>OUTPut:TRIGger&lt;port&gt;:PULSe:LENGth</code> .....	490

**OUTPut:PROBe<probe>[:POWER] <State>**

This command selects the probe connector that is supplied with power.

**Suffix:**

<probe> 1..2  
 Selects the probe power connector.

**Parameters:**

<State> ON | OFF

**Example:**            `OUTP:PROB2 ON`  
 Supplies the 5-pin probe connector with power.

**Manual operation:** See "[Probe Power Supply](#)" on page 160

#### **OUTPut:TRIGger<port>:DIRection <Direction>**

This command selects the trigger direction for trigger ports that serve as an input as well as an output.

**Suffix:**  
 <port>                Selects the used trigger port.  
                           2 = trigger port 2 (front)  
                           3 = trigger port 3 (rear panel)

**Parameters:**  
 <Direction>            **INPut**  
                               Port works as an input.  
                               **OUTPut**  
                               Port works as an output.  
                               \*RST:            INPut

**Manual operation:** See "[Trigger 2/3](#)" on page 161

#### **OUTPut:TRIGger<port>:LEVel <Level>**

This command defines the level of the (TTL compatible) signal generated at the trigger output.

This command works only if you have selected a user defined output with `OUTPut:TRIGger<port>:OTYPe`.

**Suffix:**  
 <port>                Selects the trigger port to which the output is sent.  
                           2 = trigger port 2 (front)  
                           3 = trigger port 3 (rear)

**Parameters:**  
 <Level>                **HIGH**  
                               5 V  
                               **LOW**  
                               0 V  
                               \*RST:            LOW

**Example:**            `OUTP:TRIG2:LEV HIGH`

**Manual operation:** See "[Level](#)" on page 161

#### **OUTPut:TRIGger<port>:OTYPe <OutputType>**

This command selects the type of signal generated at the trigger output.



**Suffix:**

<port>                      Selects the trigger port to which the output is sent.  
 2 = trigger port 2 (front)  
 3 = trigger port 3 (rear)

**Parameters:**

<OutputType>

**DEvice**

Sends a trigger signal when the R&S ESW has triggered internally.

**TARMed**

Sends a trigger signal when the trigger is armed and ready for an external trigger event.

**UDEfined**

Sends a user defined trigger signal. For more information see [OUTPut:TRIGger<port>:LEVel](#).

\*RST:            DEvice

**Manual operation:**    See " [Output Type](#) " on page 161

**OUTPut:TRIGger<port>:PULSe:IMMediate**

This command generates a pulse at the trigger output.

**Suffix:**

<port>                      Selects the trigger port to which the output is sent.  
 2 = trigger port 2 (front)  
 3 = trigger port 3 (rear)

**Usage:**                      Event

**Manual operation:**    See " [Send Trigger](#) " on page 162

**OUTPut:TRIGger<port>:PULSe:LENGth <Length>**

This command defines the length of the pulse generated at the trigger output.

**Suffix:**

<port>                      Selects the trigger port to which the output is sent.  
 2 = trigger port 2 (front)  
 3 = trigger port 3 (rear)

**Parameters:**

<Length>                    Pulse length in seconds.

**Example:**                    OUTP:TRIG2:PULS:LENG 0.02

**Manual operation:**    See " [Pulse Length](#) " on page 162

### 13.6.3 Frequency Configuration

CALCulate<n>:MARKer<m>:FUNction:STRack[:STATe].....	491
CALCulate<n>:MARKer<m>:FUNction:STRack:BANDwidth.....	491
CALCulate<n>:MARKer<m>:FUNction:STRack:THReshold.....	492
CALCulate<n>:MARKer<m>:FUNction:STRack:TRACe.....	492
DISPlay[:WINDow<n>]:TRACe<t>:X:SPACing.....	492
[SENSe:]FREQUency:CENTer.....	493
[SENSe:]FREQUency:CENTer:STEP.....	493
[SENSe:]FREQUency:SPAN.....	493

---

#### CALCulate<n>:MARKer<m>:FUNction:STRack[:STATe] <State>

This command turns signal tracking on and off.

**Suffix:**

<n>, <m>                      irrelevant

**Parameters:**

<State>                      ON | OFF | 1 | 0  
 \*RST:                        0

**Example:**

```
//Activate signal tracking to keep the center frequency on the signal peak
//After each sweep the maximum on trace 1 is searched within a range of 20MHz
//around the center frequency. It must have a minimum power of -90dBm.
CALC:MARK:FUNC:STR ON
CALC:MARK:FUNC:STR:BAND 20MHz
CALC:MARK:FUNC:STR:THR -90dBm
CALC:MARK:FUNC:STR:TRAC 1
```

**Manual operation:** See " [Signal Tracking](#) " on page 170  
 See " [IF Signal Tracking](#) " on page 173

---

#### CALCulate<n>:MARKer<m>:FUNction:STRack:BANDwidth <Bandwidth>

This command defines the bandwidth around the center frequency that is included in the signal tracking process.

Note that you have to turn on signal tracking before you can use the command.

**Suffix:**

<n>, <m>                      irrelevant

**Parameters:**

<Bandwidth>                Range:        10 Hz to Max span  
 \*RST:                        (= span/10 on activating the function)  
 Default unit: Hz

**Manual operation:** See " [Signal Tracking](#) " on page 170  
 See " [IF Signal Tracking](#) " on page 173

**CALCulate<n>:MARKer<m>:FUNCTION:STRack:THReshold <Level>**

This command defines the threshold level for the signal tracking process.

Note that you have to turn on signal tracking before you can use the command.

**Suffix:**

<n>, <m>                    irrelevant

**Parameters:**

<Level>                    The unit depends on `CALCulate<n>:UNIT:POWER`.

Range:            -130 dBm to 30 dBm

\*RST:            -120 dBm

**Manual operation:**    See " [Signal Tracking](#) " on page 170  
                                  See " [IF Signal Tracking](#) " on page 173

**CALCulate<n>:MARKer<m>:FUNCTION:STRack:TRACe <TraceNumber>**

This command selects the trace on which the largest signal is searched for.

**Suffix:**

<n>, <m>                    irrelevant

**Parameters:**

<TraceNumber>            1 to 6

Range:            1 to 6

\*RST:            1

**Manual operation:**    See " [Signal Tracking](#) " on page 170  
                                  See " [IF Signal Tracking](#) " on page 173

**DISPlay[:WINDow<n>]:TRACe<t>:X:SPACing <Scale>**

This command selects the scale of the x-axis.

**Suffix:**

<n>                            irrelevant

<t>                            irrelevant

**Parameters:**

<Scale>                    **LINear**  
                                  Linear scale of the frequency axis.

**LOGarithmic**  
                                  Logarithmic scale of the frequency axis.

\*RST:            LOGarithmic

**Example:**                `DISP:TRAC:X:SPAC LIN`  
                                  Selects a linear scale for the x-axis.

**Manual operation:**    See " [Frequency Axis Scale](#) " on page 172

**[SENSe:]FREQuency:CENTer <Frequency>**

This command defines the measurement frequency for measurements in the frequency or time domain.

**Parameters:**

<Frequency>                    <numeric value>  
                                       Numeric value in Hz.  
                                       Range:        Refer to the datasheet  
                                       \*RST:        fmax / 2  
                                       Default unit: Hz

**Example:**                    //Define receiver frequency  
                                       FREQ:CENT 100MHz

**Manual operation:**    See "[Receiver Frequency](#)" on page 171

**[SENSe:]FREQuency:CENTer:STEP <StepSize>**

This command defines the center frequency step size.

**Parameters:**

<StepSize>                    <numeric value>  
                                       Numeric value in Hz.

**Example:**                    //Define frequency step size  
                                       FREQ:CENT:STEP 4KHZ

**Manual operation:**    See "[Frequency Stepsize](#)" on page 173

**[SENSe:]FREQuency:SPAN <Span>**

This command defines the frequency span.

**Manual operation:**    See "[IF Analysis](#)" on page 172

### 13.6.4 Amplitude Configuration

<a href="#">CALCulate&lt;n&gt;:UNIT:POWER</a> .....	493
<a href="#">INPut&lt;ip&gt;:ATTenuation</a> .....	494
<a href="#">INPut&lt;ip&gt;:ATTenuation:AMODE</a> .....	494
<a href="#">INPut&lt;ip&gt;:ATTenuation:AUTO</a> .....	494
<a href="#">INPut&lt;ip&gt;:ATTenuation:PROTection[:STATe]</a> .....	495
<a href="#">INPut&lt;ip&gt;:GAIN:AUTO</a> .....	495
<a href="#">INPut&lt;ip&gt;:GAIN:LNA:AUTO</a> .....	495
<a href="#">INPut&lt;ip&gt;:GAIN:LNA:STATe</a> .....	496
<a href="#">INPut&lt;ip&gt;:GAIN:STATe</a> .....	496

**CALCulate<n>:UNIT:POWER <Unit>**

This command selects the unit for the y-axis.

**Suffix:**

<n> irrelevant

**Example:**

```
CALC:UNIT:POW DBM
Selects the unit dBm.
```

**Manual operation:**

See "Unit" on page 166  
See "dBx/MHz" on page 167

**INPut<ip>:ATTenuation <Attenuation>**

This command defines the attenuation at the RF input.

To protect the input mixer, attenuation levels of 10 dB or less are possible only if you have turned off the input protection with `INPut<ip>:ATTenuation:PROTection[:STATe]` on page 495.

**Suffix:**

<ip> irrelevant

**Parameters:**

<Attenuation> numeric value  
Range: 0 dB to 79 dB  
\*RST: 10 dB  
Default unit: dB

**Example:**

```
//Define attenuation
INP:ATT 40dB
```

**Manual operation:**

See "Attenuation" on page 116

**INPut<ip>:ATTenuation:AMODE <Mode>**

This command selects the auto ranging mode.

**Suffix:**

<ip> irrelevant

**Parameters:**

<Mode> **LOWNoise**  
Selects the Low Noise mode.  
**NORMal**  
Selects the Normal mode.

**Example:**

```
//Select low noise auto ranging mode
INP:ATT:AMOD LOWN
```

**Manual operation:**

See "Auto Range" on page 115

**INPut<ip>:ATTenuation:AUTO <State>**

This command turns automatic determination of the attenuation level on and off.

When you turn it on, the R&S ESW selects an attenuation that results in a good signal-to-noise ratio without overloading the RF input.

**Suffix:**

<ip> irrelevant

**Parameters:**

<State> ON | OFF

**ON**

Receiver: Turns on the auto ranging feature.

**OFF**

Receiver: Turns off the auto ranging feature.

\*RST: ON

**Example:**

```
//Turn on auto ranging
INP:ATT:AUTO ON
```

**Manual operation:**

See ["Auto Range"](#) on page 115  
See ["Attenuation"](#) on page 116

**INPut<ip>:ATTenuation:PROTection[:STATe] <State>**

This command turns the availability of attenuation levels of 10 dB or less on and off.

**Parameters:**

<State> ON | OFF | 1 | 0

\*RST: 1

**Example:**

```
//Turn on input protection
INP:ATT:PROT ON
```

**Manual operation:**

See ["10 dB Minimum Attenuation"](#) on page 166

**INPut<ip>:GAIN:AUTO <State>**

This command includes and excludes the preamplifier from the auto ranging feature.

**Suffix:**

<ip> irrelevant

**Parameters:**

<State> ON | OFF

\*RST: OFF

**Example:**

```
//Consider preamplifier for auto ranging
INP:GAIN:AUTO ON
```

**Manual operation:**

See ["Preamplifier"](#) on page 116

**INPut<ip>:GAIN:LNA:AUTO <State>**

This command includes and excludes the optional low noise amplifier from the auto ranging feature.

**Suffix:**  
 <ip> irrelevant

**Parameters:**  
 <State> ON | OFF  
 \*RST: OFF

**Example:** //Allow to turn the amplifier on and off manually  
 INP:GAIN:LNA:STAT ON  
 INP:GAIN:LNA:AUTO OFF

**Usage:** SCPI confirmed

**Manual operation:** See "Preamplifier" on page 116

#### INPut<ip>:GAIN:LNA:STATe <State>

This command turns the optional low noise amplifier on and off.

Note that it is not possible to use the low noise amplifier and the preamplifier at the same time.

**Suffix:**  
 <ip> irrelevant

**Parameters:**  
 <State> ON | OFF  
 \*RST: OFF

**Example:** //Turn on low noise preamplifier  
 INP:GAIN:LNA:STAT ON

**Usage:** SCPI confirmed

**Manual operation:** See "Preamplifier" on page 116

#### INPut<ip>:GAIN:STATe <State>

This command turns the preamplifier on and off.

**Suffix:**  
 <ip> irrelevant

**Parameters:**  
 <State> ON | OFF  
 \*RST: OFF

**Example:** //Turn on preamplifier  
 INP:GAIN:STAT ON

**Manual operation:** See "Preamplifier" on page 116

### 13.6.5 Diagram Scale

DISPlay[:WINDow<n>]:TRACe<t>:Y[:SCALe].....	497
DISPlay[:WINDow<n>]:TRACe<t>:Y[:SCALe]:BOTTom.....	497

---

#### DISPlay[:WINDow<n>]:TRACe<t>:Y[:SCALe] <Range>

This command defines the display range of the y-axis (for all traces).

##### Suffix:

<n>	Window
<t>	irrelevant

##### Parameters:

<Range>	Range:	1 dB to 200 dB
	*RST:	100 dB

**Example:**           DISP:TRAC:Y 110dB

**Manual operation:** See "Grid Range / Minimum Level" on page 168

---

#### DISPlay[:WINDow<n>]:TRACe<t>:Y[:SCALe]:BOTTom <Level>

This command defines the minimum level displayed on the vertical diagram axis.

##### Suffix:

<n>	Window
<t>	irrelevant

##### Parameters:

<Level>	Minimum displayed level. The unit and value range depend on the unit you have selected.
	*RST:       0 dB $\mu$ V

**Example:**           DISP:TRAC:Y:BOTM -20  
The minimum grid level is set to -20 dB $\mu$ V (pre-condition: the default unit has not been changed)

**Usage:**               SCPI confirmed

**Manual operation:** See "Grid Range / Minimum Level" on page 168

### 13.6.6 Bandwidth and Filter Configuration

[SENSe:]BWIDth:IF.....	498
[SENSe:]BANDwidth:IF.....	498
[SENSe:]BWIDth[:RESolution].....	498
[SENSe:]BANDwidth[:RESolution][:VALue].....	498
[SENSe:]BWIDth:SCPL.....	498
[SENSe:]BANDwidth:SCPL.....	498
[SENSe:]BWIDth[:RESolution]:AUTO.....	499
[SENSe:]BANDwidth[:RESolution]:AUTO.....	499



[SENSe:]BWIDth[:RESolution]:TYPE.....	499
[SENSe:]BANDwidth[:RESolution]:TYPE.....	499

---

**[SENSe:]BWIDth:IF** <Bandwidth>  
**[SENSe:]BANDwidth:IF** <Bandwidth>

This command defines the resolution bandwidth for IF analysis.

**Parameters:**

<Bandwidth>                      <numeric value>  
 The available bandwidths depend on the span.  
 Default unit: Hz

**Example:**                      //Define resolution bandwidth for IF analysis  
 BAND:IF 10KHZ

**Manual operation:**    See "[IF Analysis](#)" on page 172

---

**[SENSe:]BWIDth[:RESolution]** <Bandwidth>  
**[SENSe:]BANDwidth[:RESolution][:VALue]** <Bandwidth>

This command defines the measurement (or resolution) bandwidth.

The available bandwidths depend on the selected filter type.

A change of the resolution bandwidth automatically turns the coupling to the frequency off.

**Parameters:**

<Bandwidth>                      <numeric value>  
 Refer to the datasheet for available bandwidths.  
 Default unit: Hz

**Example:**                      //Select measurement bandwidth  
 BAND 3MHZ

**Usage:**                      SCPI confirmed

**Manual operation:**    See "[Measurement Bandwidth](#)" on page 96

---

**[SENSe:]BWIDth:SCPL** <State>  
**[SENSe:]BANDwidth:SCPL** <State>

This command couples or decouples the IF span to the measurement bandwidth used for the bargraph.

**Parameters:**

<State>                      ON | OFF | 1 | 0  
 \*RST:                      ON

**Example:**                      //Decouple span from the measurement bandwidth.  
 BAND:SCPL OFF

**Manual operation:**    See "[IF Analysis](#)" on page 172

---

**[SENSe:]BWIDth[:RESolution]:AUTO** <State>

**[SENSe:]BANDwidth[:RESolution]:AUTO** <State>

This command couples or decouples the resolution bandwidth to the selected frequency.

The resolution bandwidth is coupled to the frequency only if you have selected the Quasipeak, CISPR Average or CISPR RMS detector.

**Parameters:**

<State>                    ON | OFF | 1 | 0  
 \*RST:                    ON

**Example:**                //Decouple measurement bandwidth from frequency range  
 BAND:AUTO OFF

**Usage:**                    SCPI confirmed

**Manual operation:**    See "[CISPR RBW Uncoupled](#)" on page 175

---

**[SENSe:]BWIDth[:RESolution]:TYPE** <FilterType>

**[SENSe:]BANDwidth[:RESolution]:TYPE** <FilterType>

This command selects the resolution filter type.

When you change the filter type, the command selects the next larger filter bandwidth if the same bandwidth is unavailable for that filter.

**Parameters:**

<FilterType>              **NORMAL**  
 3 dB Gauss filters

**RRC**  
 RRC filters

**CISPr | PULSe**  
 6 dB CISPR filter  
 Return value for query is always PULS.

**MIL**  
 6 dB MIL standard filter

\*RST:                    Depends on application

**Example:**                BAND:TYPE NORM

**Manual operation:**    See "[Filter Type](#)" on page 96

### 13.6.7 Trigger Configuration

<a href="#">[SENSe:]SWEep:EGATe:HOLDoff</a> .....	500
<a href="#">[SENSe:]SWEep:EGATe:LENGth</a> .....	500
<a href="#">[SENSe:]SWEep:EGATe:POLarity</a> .....	500
<a href="#">[SENSe:]SWEep:EGATe:SOURce</a> .....	500
<a href="#">[SENSe:]SWEep:EGATe[:STATe]</a> .....	501
<a href="#">[SENSe:]SWEep:EGATe:TYPE</a> .....	501

TRIGger<n>[:SEQuence]:HOLDoff[:TIME].....	502
TRIGger<n>[:SEQuence]:LEVel[:EXTernal<port>].....	502
TRIGger<n>[:SEQuence]:SLOPe.....	503
TRIGger<n>[:SEQuence]:SOURce.....	503

---

#### [SENSe:]SWEep:EGATe:HOLDoff <DelayTime>

This command defines the delay time between the gate signal and the continuation of the measurement.

##### Parameters:

<DelayTime>            Range:     0 s to 30 s  
                              \*RST:     0 s

**Example:**            SWE:EGAT:HOLD 100us

**Manual operation:** See " [Gate Delay](#) " on page 180

---

#### [SENSe:]SWEep:EGATe:LENGth <GateLength>

This command defines the gate length.

##### Parameters:

<GateLength>           Range:     125 ns to 30 s  
                              \*RST:     400µs

**Example:**            SWE:EGAT:LENG 10ms

**Manual operation:** See " [Gate Length](#) " on page 181

---

#### [SENSe:]SWEep:EGATe:POLarity <Polarity>

This command selects the polarity of an external gate signal.

The setting applies both to the edge of an edge-triggered signal and the level of a level-triggered signal.

##### Parameters:

<Polarity>            POSitive | NEGative  
                              \*RST:     POSitive

**Example:**            SWE:EGAT:POL POS

---

#### [SENSe:]SWEep:EGATe:SOURce <TriggerSource>

This command selects a trigger source for gated measurements.

If an IF power signal is used, the gate is opened as soon as a signal at > -20 dBm is detected within the IF path bandwidth (10 MHz).

**Parameters:**

<TriggerSource>    **EXTernal | EXT2 | EXT3**  
 Selects one of the external trigger connectors.

**IMMediate**

Free Run mode (= no trigger)

\*RST:            IMMediate

**Example:**

```
//Turn on a gated measurement using the first trigger input
SWE:EGAT ON
SWE:EGAT:SOUR EXT
```

**Usage:**

SCPI confirmed

**Manual operation:** See "[Trigger Source](#)" on page 179

**[SENSe:]SWEep:EGATe:STATe** <State>

This command turns gated measurements on and off.

In case of measurements with an external gate, the measured values are recorded as long as the gate is opened. During a measurement the gate can be opened and closed several times. The synchronization mechanisms with \*OPC, \*OPC? and \*WAI remain completely unaffected.

**Parameters:**

<State>            ON | OFF | 1 | 0  
 \*RST:            0

**Example:**

```
SWE:EGAT ON
Switches on the external gate mode.
SWE:EGAT:TYPE EDGE
Switches on the edge-triggered mode.
SWE:EGAT:HOLD 100US
Sets the gate delay to 100 µs.
SWE:EGAT:LEN 500US
Sets the gate opening time to 500 µs.
INIT;*WAI
Starts a sweep and waits for its end.
```

**Manual operation:** See "[Gated Trigger](#)" on page 180

**[SENSe:]SWEep:EGATe:TYPE** <Type>

This command selects the way gated measurements are triggered.

**Parameters:**

&lt;Type&gt;

**LEVel**

The trigger event for the gate to open is a particular power level. After the gate signal has been detected, the gate remains open until the signal disappears.

**EDGE**

The trigger event for the gate to open is the detection of the signal edge.

After the gate signal has been detected, the gate remains open until the gate length is over.

\*RST: EDGE

**Example:**

SWE:EGAT:TYPE EDGE

**Manual operation:** See " [Gate Mode](#) " on page 180

**TRIGger<n>[:SEQuence]:HOLDoff[:TIME] <Offset>**

Defines the time offset between the trigger event and the start of the measurement (data capturing).

A negative offset is possible for time domain measurements.

For the trigger sources "External" or "IF Power", a common input signal is used for both trigger and gate. Therefore, changes to the gate delay affect the trigger offset as well.

**Suffix:**

&lt;n&gt;

irrelevant

**Parameters:**

&lt;Offset&gt;

For measurements in the frequency domain, the range is 0 s to 30 s.

For measurements in the time domain, the range is the negative sweep time to 30 s.

\*RST: 0 s

**Example:**

TRIG:HOLD 500us

Defines a trigger offset of 500 µs.

**Manual operation:** See "[Trigger Offset](#)" on page 180

**TRIGger<n>[:SEQuence]:LEVel[:EXTernal<port>] <Level>**

This command defines the level the external signal must exceed to cause a trigger event.

Note that the variable [Input/Output] connectors must be set for use as input using the [OUTPut:TRIGger<port>:DIRection](#) command.

**Suffix:**

&lt;n&gt;

irrelevant

<port>                      Selects the trigger port.  
                                  1 = trigger port 1 (TRIGGER INPUT connector on front panel)  
                                  2 = trigger port 2 (TRIGGER INPUT/OUTPUT connector on front panel)

**Parameters:**

<Level>                      Numeric value in V.

**Example:**

```
TRIG:SOUR EXT
TRIG:LEV 2V
```

Defines a trigger level of 2 V for an external trigger source.

**Manual operation:**    See "[Trigger Level](#)" on page 179

**TRIGger<n>[:SEQUence]:SLOPe <Type>**

This command selects the trigger slope.

**Suffix:**

<n>                              irrelevant

**Parameters:**

<Type>                        **POSitive**  
                                  Triggers when the signal rises to the trigger level (rising edge).  
                                  **NEGative**  
                                  Triggers when the signal drops to the trigger level (falling edge).  
                                  \*RST:            POSitive

**Example:**

```
TRIG:SLOP NEG
```

**Manual operation:**    See "[Trigger Slope](#)" on page 180

**TRIGger<n>[:SEQUence]:SOURce <Source>**

This command selects the trigger source.

**Note on external triggers:**

If a measurement is configured to wait for an external trigger signal in a remote control program, remote control is blocked until the trigger is received and the program can continue. Make sure that this situation is avoided in your remote control programs.

For troubleshooting tips, see "[Incompleted sequential commands - blocked remote channels](#)" on page 716.

**Suffix:**

<n>                              irrelevant

**Parameters:**

<Source>                      See table below.  
                                  \*RST:            IMMEDIATE

**Example:**

```
TRIG:SOUR EXT
```

Selects the external trigger input as source of the trigger signal

**Manual operation:** See "Trigger Source" on page 179  
 See "Free Run" on page 179  
 See "Ext. Trigger 1/2" on page 179

Table 13-3: Available trigger sources

SCPI parameter	Trigger source
EXTernal	Trigger signal from the [Trigger Input] connector.
EXT2   EXT3	Trigger signal from the [Trigger Input/Output] connector. Note: Connector must be configured for "Input".
IMMEDIATE	Free Run trigger.

## 13.7 Analysis

- [Result Display Configuration](#).....504
- [Zoomed Displays](#)..... 513
- [Trace Configuration](#).....514
- [Markers](#)..... 524
- [Display and Limit Line Configuration](#).....548

### 13.7.1 Result Display Configuration

- [General Window Commands](#)..... 504
- [Screen Layout](#).....505
- [Examples: Configuring the Result Display](#)..... 511

#### 13.7.1.1 General Window Commands

Note that the suffix <n> always refers to the window in the currently selected measurement channel.

- [DISPlay:FORMat](#)..... 504
- [DISPlay\[:WINDow<n>\]:SIZE](#)..... 505

---

#### DISPlay:FORMat <Format>

This command determines which tab is displayed.

#### Parameters:

<Format>

#### SPLit

Displays the MultiView tab with an overview of all active channels

#### SINGle

Displays the measurement channel that was previously focused.

\*RST: SING

#### Example:

DISP:FORM SPL

**DISPlay[:WINDow<n>]:SIZE <Size>**

This command maximizes the size of the selected result display window *temporarily*. To change the size of several windows on the screen permanently, use the `LAYout:SPLitter` command (see `LAYout:SPLitter` on page 508).

**Suffix:**

<n>                      [Window](#)

**Parameters:**

<Size>

**LARGE**

Maximizes the selected window to full screen.  
Other windows are still active in the background.

**SMALI**

Reduces the size of the selected window to its original size.  
If more than one measurement window was displayed originally, these are visible again.

\*RST:            SMALI

**Example:**

DISP:WIND2:SIZE LARG

**13.7.1.2 Screen Layout**

The following commands are required to change the evaluation type and rearrange the screen layout for a measurement channel as you do using the SmartGrid in manual operation. Since the available evaluation types depend on the selected application, some parameters for the following commands also depend on the selected measurement channel.

Note that the suffix <n> always refers to the window in the currently selected measurement channel.

<a href="#">LAYout:ADD[:WINDow]?</a> .....	505
<a href="#">LAYout:CATalog[:WINDow]?</a> .....	506
<a href="#">LAYout:IDENtify[:WINDow]?</a> .....	507
<a href="#">LAYout:REMove[:WINDow]</a> .....	507
<a href="#">LAYout:REPLace[:WINDow]</a> .....	507
<a href="#">LAYout:SPLitter</a> .....	508
<a href="#">LAYout:WINDow&lt;n&gt;:ADD?</a> .....	509
<a href="#">LAYout:WINDow&lt;n&gt;:IDENtify?</a> .....	510
<a href="#">LAYout:WINDow&lt;n&gt;:REMove</a> .....	510
<a href="#">LAYout:WINDow&lt;n&gt;:REPLace</a> .....	510

**LAYout:ADD[:WINDow]?** <WindowName>,<Direction>,<WindowType>

This command adds a window to the display in the active channel.

This command is always used as a query so that you immediately obtain the name of the new window as a result.

To replace an existing window, use the `LAYout:REPLace[:WINDow]` command.



**Query parameters:**

- <WindowName> String containing the name of the existing window the new window is inserted next to.  
By default, the name of a window is the same as its index. To determine the name and index of all active windows, use the `LAYout:CATalog[:WINDow]? query`.
- <Direction> LEFT | RIGHT | ABOVE | BELOW  
Direction the new window is added relative to the existing window.
- <WindowType> text value  
Type of result display (evaluation method) you want to add. See the table below for available parameter values.

**Return values:**

- <NewWindowName> When adding a new window, the command returns its name (by default the same as its number) as a result.

**Usage:** Query only

*Table 13-4: <WindowType> parameter values for the Receiver application*

Parameter value	Window type
BGRaph	Bargraph
DIAGram	Diagram
FACCess	Fast Access panel
FMEas	Final measurement
IFANalysis	IF analysis diagram
IFSGram	IF analysis spectrogram
MTABle	Marker table
PLISt	Marker peak list
PRESelection	Preselector configuration
SCAN	Scan diagram
SCSGram	Scan spectrogram

**LAYout:CATalog[:WINDow]?**

This command queries the name and index of all active windows in the active channel from top left to bottom right. The result is a comma-separated list of values for each window, with the syntax:

<WindowName\_1>,<WindowIndex\_1>..<WindowName\_n>,<WindowIndex\_n>

**Return values:**

- <WindowName> string  
Name of the window.  
In the default state, the name of the window is its index.

<WindowIndex>      **numeric value**  
Index of the window.

**Example:**            LAY:CAT?  
Result:  
                  '2',2,'1',1  
Two windows are displayed, named '2' (at the top or left), and '1' (at the bottom or right).

**Usage:**              Query only

**LAYout:IDENTify[:WINDow]? <WindowName>**

This command queries the **index** of a particular display window in the active channel.

**Note:** to query the **name** of a particular window, use the [LAYout:WINDow<n>:IDENTify?](#) query.

**Query parameters:**

<WindowName>      String containing the name of a window.

**Return values:**

<WindowIndex>      Index number of the window.

**Example:**            LAY:WIND:IDEN? '2'  
Queries the index of the result display named '2'.  
Response:  
                  2

**Usage:**              Query only

**LAYout:REMOve[:WINDow] <WindowName>**

This command removes a window from the display in the active channel.

**Setting parameters:**

<WindowName>      String containing the name of the window.  
In the default state, the name of the window is its index.

**Example:**            LAY:REM '2'  
Removes the result display in the window named '2'.

**Usage:**              Event

**LAYout:REPLace[:WINDow] <WindowName>,<WindowType>**

This command replaces the window type (for example from "Diagram" to "Result Summary") of an already existing window in the active channel while keeping its position, index and window name.

To add a new window, use the [LAYout:ADD\[:WINDow\]?](#) command.

**Setting parameters:**

<WindowName> String containing the name of the existing window.  
By default, the name of a window is the same as its index. To determine the name and index of all active windows in the active channel, use the `LAYout:CATalog[:WINDow]?` query.

<WindowType> Type of result display you want to use in the existing window.  
See `LAYout:ADD[:WINDow]?` on page 505 for a list of available window types.

**Example:** `LAY:REPL:WIND '1',MTAB`  
Replaces the result display in window 1 with a marker table.

**Usage:** Setting only

**LAYout:SPLitter <Index1>,<Index2>,<Position>**

This command changes the position of a splitter and thus controls the size of the windows on each side of the splitter.

Note that windows must have a certain minimum size. If the position you define conflicts with the minimum size of any of the affected windows, the command will not work, but does not return an error.

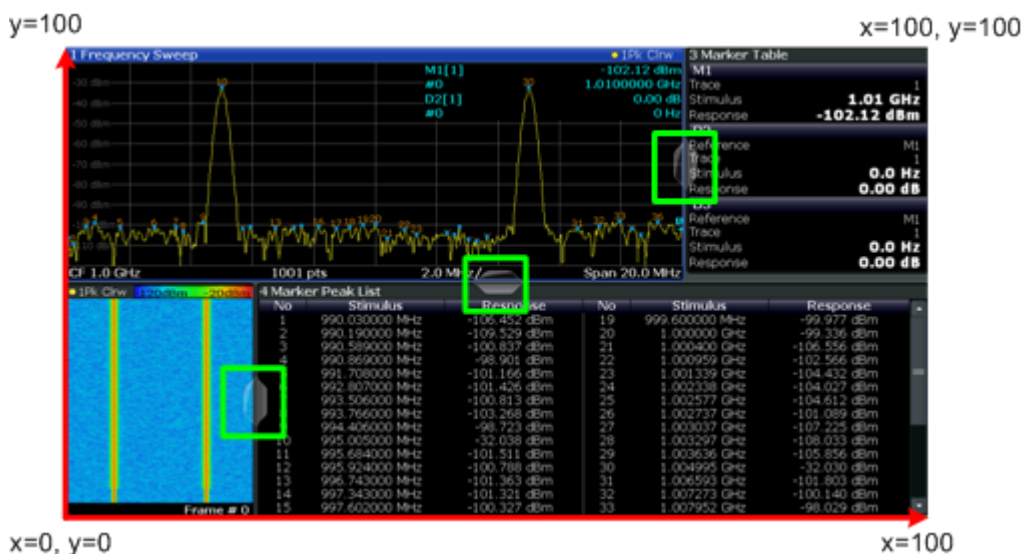

Figure 13-1: SmartGrid coordinates for remote control of the splitters

**Parameters:**

<Index1> The index of one window the splitter controls.

<Index2> The index of a window on the other side of the splitter.

<b>&lt;Position&gt;</b>	<p>New vertical or horizontal position of the splitter as a fraction of the screen area (without channel and status bar and softkey menu).</p> <p>The point of origin (x = 0, y = 0) is in the lower left corner of the screen. The end point (x = 100, y = 100) is in the upper right corner of the screen. (See <a href="#">Figure 13-1</a>.)</p> <p>The direction in which the splitter is moved depends on the screen layout. If the windows are positioned horizontally, the splitter also moves horizontally. If the windows are positioned vertically, the splitter also moves vertically.</p> <p>Range: 0 to 100</p>
<b>Example:</b>	<pre>LAY:SPL 1,3,50</pre> <p>Moves the splitter between window 1 ('Frequency Sweep') and 3 ('Marker Table') to the center (50%) of the screen, i.e. in the figure above, to the left.</p>
<b>Example:</b>	<pre>LAY:SPL 1,4,70</pre> <p>Moves the splitter between window 1 ('Frequency Sweep') and 3 ('Marker Peak List') towards the top (70%) of the screen.</p> <p>The following commands have the exact same effect, as any combination of windows above and below the splitter moves the splitter vertically.</p> <pre>LAY:SPL 3,2,70 LAY:SPL 4,1,70 LAY:SPL 2,1,70</pre>

---

#### **LAYout:WINDow<n>:ADD? <Direction>,<WindowType>**

This command adds a measurement window to the display. Note that with this command, the suffix <n> determines the existing window next to which the new window is added, as opposed to [LAYout:ADD\[:WINDow\]?](#), for which the existing window is defined by a parameter.

To replace an existing window, use the [LAYout:WINDow<n>:REPLace](#) command.

This command is always used as a query so that you immediately obtain the name of the new window as a result.

**Suffix:**

<n> [Window](#)

**Parameters:**

<Direction> LEFT | RIGHT | ABOVE | BELOW

<WindowType> Type of measurement window you want to add.  
See [LAYout:ADD\[:WINDow\]?](#) on page 505 for a list of available window types.

**Return values:**

<NewWindowName> When adding a new window, the command returns its name (by default the same as its number) as a result.

**Example:**           LAY:WIND1:ADD? LEFT,MTAB  
**Result:**  
 '2'  
 Adds a new window named '2' with a marker table to the left of window 1.

**Usage:**            Query only

#### LAYout:WINDow<n>:IDENtify?

This command queries the **name** of a particular display window (indicated by the <n> suffix) in the active channel.

**Note:** to query the **index** of a particular window, use the [LAYout:IDENtify\[:WINDow\]?](#) command.

**Suffix:**  
 <n>                    [Window](#)

**Return values:**  
 <WindowName>       String containing the name of a window.  
 In the default state, the name of the window is its index.

**Example:**           LAY:WIND2:IDEN?  
 Queries the name of the result display in window 2.  
**Response:**  
 '2'

**Usage:**            Query only

#### LAYout:WINDow<n>:REMOve

This command removes the window specified by the suffix <n> from the display in the active channel.

The result of this command is identical to the [LAYout:REMOve\[:WINDow\]](#) command.

**Suffix:**  
 <n>                    [Window](#)

**Example:**           LAY:WIND2:REM  
 Removes the result display in window 2.

**Usage:**            Event

#### LAYout:WINDow<n>:REPLace <WindowType>

This command changes the window type of an existing window (specified by the suffix <n>) in the active channel.

The effect of this command is identical to the [LAYout:REPLace\[:WINDow\]](#) command.

To add a new window, use the [LAYout:WINDow<n>:ADD?](#) command.

**Suffix:**<n> [Window](#)**Setting parameters:**

<WindowType> Type of measurement window you want to replace another one with.  
See [LAYout:ADD\[:WINDow\]?](#) on page 505 for a list of available window types.

**Example:**

LAY:WIND2:REPL MTAB

Replaces the result display in window 2 with a marker table.

**Usage:**

Setting only

**13.7.1.3 Examples: Configuring the Result Display**

The following example demonstrates how to configure result displays in a remote environment.

**Example 1: Adding and Arranging Windows**

Starting from the default initial display in the Spectrum application (Frequency Sweep), we will configure the following result displays:

1 Frequency Sweep	3 Marker Table
2 Spectrogram	4 Marker Peak List

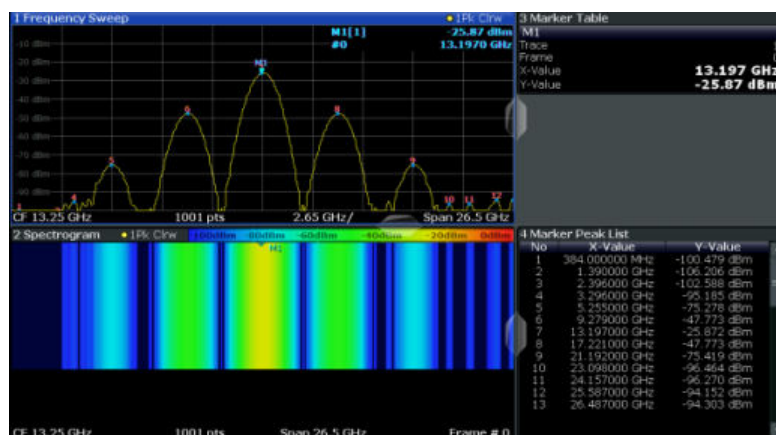

```
//-----Resetting the instrument -----
*RST
//----- Adding new windows -----
//Add a Spectrogram window beneath the Frequency Sweep window
LAY:ADD? '1',BEL,SGR
//Result: window number: '2'
//Add a Marker Table window to the right of the Frequency Sweep window
LAY:ADD? '1',RIGHT,MTAB
//Result: window number: '3'
//Add a Marker Peak List window to the right of the Spectrogram window
```

```

LAY:WIND2:ADD? RIGH,PEAK
//Result: window number: '4'

//----- Changing the size of individual windows -----
//Move the splitter between the Frequency Sweep window and the Marker Table
//window to enlarge the spectrum display to 60% of the entire width.
LAY:SPL 1,3,60
//Move the splitter between the Spectrogram window and the Marker Peak List
//window to enlarge the Spectrogram display to 60% of the entire width.
LAY:SPL 2,4,60

//----- Querying all displayed windows -----
//Query the name and number of all displayed windows
//(from top left to bottom right)
LAY:CAT?
//Result : '1',1,'2',2,'3',3,'4',4

//----- Maximizing a Window -----
//Maximize the window "2 Spectrogram"
DISP:WIND2:SIZE LARG

//-----Restore multiple window display -----
DISP:WIND2:SIZE SMAL

```

### Example 2: Replacing and Removing Windows

Starting from the display configured in [Example 1: Adding and Arranging Windows](#), we will remove and replace result displays to obtain the following configuration:

1 Frequency Sweep
4 Marker Table

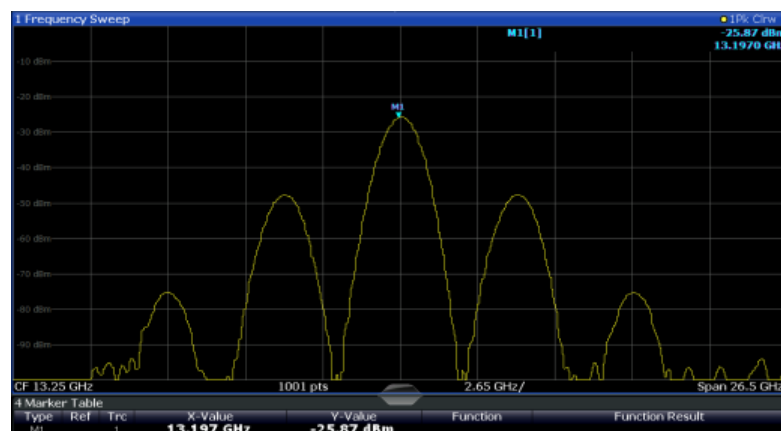

```
//----- Preparing the configuration from example 1 -----
*RST
LAY:ADD? '1',BEL,SGR
LAY:ADD? '1',RIGH,MTAB
LAY:WIND2:ADD? RIGH,PEAK
LAY:CAT?
//Result : '1',1,'2',2,'3',3,'4',4
//Remove Spectrogram
LAY:WIND2:REM //Remove Marker Table window
LAY:REM '3'
//Replace Marker Peak List window by Marker Table
LAY:REPL '4',MTAB

//----- Querying all displayed windows -----
//Query the name and number of all displayed windows (from top left to bottom right)
LAY:CAT?
//Result : '1',1,'4',4

//----- Changing the size of individual windows -----
//Move the splitter between the Frequency Sweep window and the Marker Table window
//to enlarge the spectrum display to 80% of the entire height.
LAY:SPL 1,4,80
```

### 13.7.2 Zoomed Displays

DISPlay[:WINDow<n>]:ZOOM:AREA..... 513  
 DISPlay[:WINDow<n>]:ZOOM[:STATe]..... 514

#### DISPlay[:WINDow<n>]:ZOOM:AREA <x1>,<y1>,<x2>,<y2>

This command defines the zoom area.

To define a zoom area, you first have to turn the zoom on.

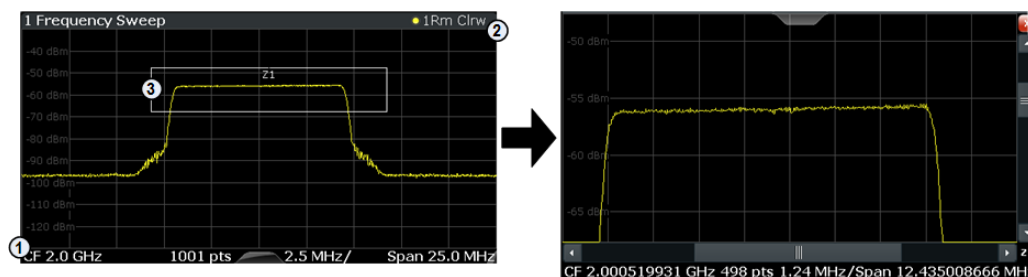

- 1 = origin of coordinate system (x1 = 0, y1 = 0)
- 2 = end point of system (x2 = 100, y2= 100)
- 3 = zoom area (e.g. x1 = 60, y1 = 30, x2 = 80, y2 = 75)

**Suffix:**

<n> Window



**Parameters:**

<x1>,<y1>  
<x2>,<y2>

Diagram coordinates in % of the complete diagram that define the zoom area.

The lower left corner is the origin of coordinate system. The upper right corner is the end point of the system.

Range: 0 to 100

Default unit: PCT

**Manual operation:** See " [Single Zoom](#) " on page 188

**DISPlay[:WINDow<n>]:ZOOM[:STATE] <State>**

This command turns the zoom on and off.

**Suffix:**

<n> [Window](#)

**Parameters:**

<State> ON | OFF | 1 | 0

\*RST: 0

**Example:**

DISP:ZOOM ON

Activates the zoom mode.

**Manual operation:** See " [Single Zoom](#) " on page 188  
See " [Restore Original Display](#) " on page 188  
See " [Deactivating Zoom \(Selection Mode\)](#) " on page 188

## 13.7.3 Trace Configuration

### 13.7.3.1 Trace Control

For a full list of commands to control traces, see [Chapter 13.5.9, "Final Measurement \(and Trace\) Configuration"](#), on page 460.

### 13.7.3.2 Trace Export

Commands to export traces described elsewhere.

- [FORMat:DEXPort:DSEPARATOR](#) on page 569

[FORMat:DEXPort:HEADer](#).....514

[FORMat:DEXPort:TRACes](#)..... 515

**FORMat:DEXPort:HEADer <State>**

If enabled, additional instrument and measurement settings are included in the header of the export file for result data. If disabled, only the pure result data from the selected traces and tables is exported.

**Parameters:**

<State> ON | OFF | 0 | 1  
 \*RST: 1

**Manual operation:** See " [Include Instrument & Measurement Settings](#) " on page 204

**FORMat:DEXPort:TRACes** <Selection>

This command selects the data to be included in a data export file (see [MMEMory:STORe<n>:TRACe](#) on page 607).

For details on exporting data, see [Chapter 9.3.3, "Trace Export"](#), on page 203.

**Parameters:**

<Selection> **SINGLE**  
 Only a single trace is selected for export, namely the one specified by the [MMEMory:STORe<n>:TRACe](#) command.

**ALL**  
 Selects all active traces and result tables (e.g. Result Summary, marker peak list etc.) in the current application for export to an ASCII file.  
 The <trace> parameter for the [MMEMory:STORe<n>:TRACe](#) command is ignored.

\*RST: SINGLE

**Manual operation:** See " [Export all Traces and all Table Results](#) " on page 204

**13.7.3.3 Traces Copy**

[TRACe<n>:COPY](#).....515

**TRACe<n>:COPY** <TraceNumber>, <TraceNumber>

This command copies data from one trace to another.

**Suffix:**

<n> [Window](#)

**Parameters:**

<TraceNumber>, **TRACE1 | TRACE2 | TRACE3 | TRACE4 | TRACE5 | TRACE6**  
 <TraceNumber> The first parameter is the destination trace, the second parameter is the source.  
 (Note the 'e' in the parameter is required!)

**Example:**

TRAC: COPY TRACE1, TRACE2  
 Copies the data from trace 2 to trace 1.

**Manual operation:** See " [Copy Trace](#) " on page 205

### 13.7.3.4 Trace Mathematics

CALCulate<n>:MATH<t>:EXPRession[:DEFine].....	516
CALCulate<n>:MATH:MODE.....	516
CALCulate<n>:MATH:POSition.....	517
CALCulate<n>:MATH:STATe.....	517

---

#### CALCulate<n>:MATH<t>:EXPRession[:DEFine] <Expression>

This command selects the mathematical expression for trace mathematics.

Prerequisites for this command

- Turn on trace mathematics with `CALCulate<n>:MATH:STATe`.

#### Suffix:

<n> [Window](#)

<t> 1...6

Trace that the result of the trace mathematics is written to.

#### Parameters:

<Expression> (TRACE<x> - TRACE<y>)

The expression selects the two traces that are subtracted from each other. You can select any trace you like as the two operands.

The result is shown in the trace defined by the suffix <t> at the MATH syntax element of the command.

#### Example:

```
//Subtract trace 2 from trace 3 and write the result to trace 4
CALC:MATH:STAT ON
CALC:MATH4:EXPR (TRACE3-TRACE2)
```

**Usage:** SCPI confirmed

**Manual operation:** See "[Trace Math Function](#)" on page 206

---

#### CALCulate<n>:MATH:MODE <Mode>

This command selects the way the R&S ESW calculates trace mathematics.

#### Suffix:

<n> [Window](#)

**Parameters:**

<Mode> For more information on the way each mode works see [Trace Math Mode](#).

**LINEar**

Linear calculation.

**LOGarithmic**

Logarithmic calculation.

**POWER**

Linear power calculation.

\*RST: LOGarithmic

**Example:**

CALC:MATH:MODE LIN  
Selects linear calculation.

**Manual operation:** See "[Trace Math Mode](#)" on page 206

**CALCulate<n>:MATH:POSition <Position>**

This command defines the position of the trace resulting from the mathematical operation.

**Suffix:**

<n> [Window](#)

**Parameters:**

<Position> Vertical position of the trace in % of the height of the diagram area.

100 PCT corresponds to the upper diagram border.

Range: -100 to 200

\*RST: 50

Default unit: PCT

**Example:**

CALC:MATH:POS 100  
Moves the trace to the top of the diagram area.

**Manual operation:** See "[Trace Math Position](#)" on page 206

**CALCulate<n>:MATH:STATe <State>**

This command turns the trace mathematics on and off.

**Suffix:**

<n> [Window](#)

**Parameters:**

<State> ON | OFF | 1 | 0

\*RST: OFF

**Example:**

//Turn on trace mathematics  
CALC:MATH:STAT ON

**Usage:**

SCPI confirmed

**Manual operation:** See "Trace Math Function" on page 206

### 13.7.3.5 Spectrogram Configuration

Commands to configure spectrograms described elsewhere.

- Chapter 13.7.4.6, "Spectrogram Markers", on page 540
- [Spectrogram Settings](#)..... 518
- [Color Map Configuration](#)..... 522

#### Spectrogram Settings

<a href="#">CALCulate&lt;n&gt;:SGRam:CLEar[:IMMediate]</a> .....	518
<a href="#">CALCulate&lt;n&gt;:SPECtrogram:CLEar[:IMMediate]</a> .....	518
<a href="#">CALCulate&lt;n&gt;:SGRam:FRAMe:SElect</a> .....	518
<a href="#">CALCulate&lt;n&gt;:SPECtrogram:FRAMe:SElect</a> .....	518
<a href="#">CALCulate&lt;n&gt;:SGRam:HDEPth</a> .....	519
<a href="#">CALCulate&lt;n&gt;:SPECtrogram:HDEPth</a> .....	519
<a href="#">CALCulate&lt;n&gt;:SGRam:TRACe</a> .....	519
<a href="#">CALCulate&lt;n&gt;:SPECtrogram:TRACe</a> .....	519
<a href="#">CALCulate&lt;n&gt;:SGRam:TSTamp:DATA?</a> .....	520
<a href="#">CALCulate&lt;n&gt;:SPECtrogram:TSTamp:DATA?</a> .....	520
<a href="#">CALCulate&lt;n&gt;:SGRam:TSTamp[:STATe]</a> .....	521
<a href="#">CALCulate&lt;n&gt;:SPECtrogram:TSTamp[:STATe]</a> .....	521
<a href="#">CALCulate&lt;n&gt;:SGRam[:STATe]</a> .....	521
<a href="#">CALCulate&lt;n&gt;:SPECtrogram[:STATe]</a> .....	521

---

#### **CALCulate<n>:SGRam:CLEar[:IMMediate]**

#### **CALCulate<n>:SPECtrogram:CLEar[:IMMediate]**

This command resets the spectrogram and clears the history buffer.

#### **Suffix:**

<n> Receiver appliation: [Window](#)  
 I/Q Analyzer: [Window](#)  
 Spectrum application: irrelevant  
 Real-Time application: irrelevant

#### **Example:**

`CALC:SGR:CLE`  
 Resets the result display and clears the memory.

#### **Usage:**

Event

**Manual operation:** See " [Clear Spectrogram](#) " on page 209

---

#### **CALCulate<n>:SGRam:FRAMe:SElect <Frame> | <Time>**

#### **CALCulate<n>:SPECtrogram:FRAMe:SElect <Frame> | <Time>**

This command selects a specific frame for further analysis.

The command is available if no measurement is running or after a single sweep has ended.

**Suffix:**

<n> Receiver application: [Window](#)  
 I/Q Analyzer: [Window](#)  
 Spectrum application: irrelevant  
 Real-Time application: irrelevant

**Parameters:**

<Frame> Selects a frame directly by the frame number. Valid if the time stamp is off.  
 The range depends on the history depth.

<Time> Selects a frame via its time stamp. Valid if the time stamp is on.  
 The number is the distance to frame 0 in seconds. The range depends on the history depth.

**Example:**

```
INIT:CONT OFF
Stop the continuous sweep.
CALC:SGR:FRAM:SEL -25
Selects frame number -25.
```

**Manual operation:** See "[Select Frame](#)" on page 208

**CALCulate<n>:SGRam:HDEPth <History>**

**CALCulate<n>:SPECtrogram:HDEPth <History>**

This command defines the number of frames to be stored in the R&S ESW memory.

**Suffix:**

<n> Receiver application: [Window](#)  
 I/Q Analyzer: [Window](#)  
 Spectrum application: irrelevant  
 Real-Time application: irrelevant

**Parameters:**

<History> The maximum number of frames depends on the number of sweep points.

Range: 781 to 20000  
 Increment: 1  
 \*RST: 3000

**Example:**

```
CALC:SGR:SPEC 1500
Sets the history depth to 1500.
```

**Manual operation:** See "[History Depth](#)" on page 208

**CALCulate<n>:SGRam:TRACe**

**CALCulate<n>:SPECtrogram:TRACe <Trace>**

This command selects the trace the spectrogram is based on.

**Suffix:**

<n> Receiver application: [Window](#)  
 I/Q Analyzer: [Window](#)  
 Spectrum application: irrelevant  
 Real-Time application: irrelevant

**Parameters:**

<Trace> numeric value  
 Number of the trace. The range depends on the result display:  
 Scans support six traces, IF Analysis supports three traces.

**Example:**

`CALC:SPEC:TRAC 2`  
 Assigns trace two to the spectrogram.

**Manual operation:** See "[Trace](#)" on page 209

**CALCulate<n>:SGRam:TSTamp:DATA? <Frames>**

**CALCulate<n>:SPECtrogram:TSTamp:DATA? <Frames>**

This command queries the starting time of the frames.

The return values consist of four values for each frame. If the Spectrogram is empty, the command returns '0,0,0,0'. The times are given as delta values, which simplifies evaluating relative results; however, you can also calculate the absolute date and time as displayed on the screen.

The frame results themselves are returned with `TRAC:DATA? SGR`

**Suffix:**

<n> Receiver application: [Window](#)  
 I/Q Analyzer: [Window](#)  
 Spectrum application: irrelevant  
 Real-Time application: irrelevant

**Query parameters:**

<Frames> **CURRent**  
 Returns the starting time of the current frame.

**ALL**  
 Returns the starting time for all frames. The results are sorted in descending order, beginning with the current frame.

**Return values:**

<Seconds> Number of seconds that have passed since 01.01.1970 till the frame start

<Nanoseconds> Number of nanoseconds that have passed *in addition to the* <Seconds> since 01.01.1970 till the frame start.

<Reserved> The third and fourth value are reserved for future uses.

**Example:**

`CALC:SGR:TST ON`  
 Activates the time stamp.

`CALC:SGR:TST:DATA? ALL`  
 Returns the starting times of all frames sorted in a descending order.

**Usage:** Query only  
**Manual operation:** See " [Time Stamp](#) " on page 209

**CALCulate<n>:SGRam:TSTamp[:STATE] <State>**  
**CALCulate<n>:SPECTrogram:TSTamp[:STATE] <State>**

This command activates and deactivates the time stamp.

If the time stamp is active, some commands do not address frames as numbers, but as (relative) time values:

- [CALCulate<n>:DELTaMarker<m>:SPECTrogram:FRAMe](#) on page 545
- [CALCulate<n>:MARKer<m>:SPECTrogram:FRAMe](#) on page 540
- [CALCulate<n>:SPECTrogram:FRAMe:SElect](#) on page 518

**Suffix:**

<n> Receiver application: [Window](#)  
 I/Q Analyzer: [Window](#)  
 Spectrum application: irrelevant  
 Real-Time application: irrelevant

**Parameters:**

<State> ON | OFF | 1 | 0  
 \*RST: 0

**Example:** CALC:SGR:TST ON  
 Activates the time stamp.

**Manual operation:** See " [Time Stamp](#) " on page 209

**CALCulate<n>:SGRam[:STATE] <State>**  
**CALCulate<n>:SPECTrogram[:STATE] <State>**

This command turns the spectrogram on and off.

**Suffix:**

<n> Receiver application: [Window](#)  
 I/Q Analyzer: [Window](#)  
 Spectrum application: irrelevant  
 Real-Time application: irrelevant

**Parameters:**

<State> ON | OFF | 1 | 0  
 \*RST: 0

**Example:** CALC:SGR ON  
 Activates the Spectrogram result display.

**Manual operation:** See "[State](#)" on page 208



**Color Map Configuration**

DISPlay[:WINDow<n>]:SGRam:COLor:DEFault.....	522
DISPlay[:WINDow<n>]:SPECTrogram:COLor:DEFault.....	522
DISPlay[:WINDow<n>]:SGRam:COLor:LOWer.....	522
DISPlay[:WINDow<n>]:SPECTrogram:COLor:LOWer.....	522
DISPlay[:WINDow<n>]:SGRam:COLor:SHAPE.....	522
DISPlay[:WINDow<n>]:SPECTrogram:COLor:SHAPE.....	522
DISPlay[:WINDow<n>]:SGRam:COLor:UPPer.....	523
DISPlay[:WINDow<n>]:SPECTrogram:COLor:UPPer.....	523
DISPlay[:WINDow<n>]:SGRam:COLor[:STYLe].....	523
DISPlay[:WINDow<n>]:SPECTrogram:COLor[:STYLe].....	523

**DISPlay[:WINDow<n>]:SGRam:COLor:DEFault****DISPlay[:WINDow<n>]:SPECTrogram:COLor:DEFault**

This command restores the original color map.

**Suffix:**

<n>                      Window

**Usage:**                      Event

**Manual operation:**    See " [Set to Default](#) " on page 211

**DISPlay[:WINDow<n>]:SGRam:COLor:LOWer <Percentage>****DISPlay[:WINDow<n>]:SPECTrogram:COLor:LOWer <Percentage>**

This command defines the starting point of the color map.

**Suffix:**

<n>                      Window

**Parameters:**

<Percentage>              Statistical frequency percentage.

Range:              0 to 66

\*RST:              0

Default unit: %

**Example:**                      DISP:WIND:SGR:COL:LOW 10

Sets the start of the color map to 10%.

**Manual operation:**    See " [Start / Stop](#) " on page 210

**DISPlay[:WINDow<n>]:SGRam:COLor:SHAPE <Shape>****DISPlay[:WINDow<n>]:SPECTrogram:COLor:SHAPE <Shape>**

This command defines the shape and focus of the color curve for the spectrogram result display.

**Suffix:**

<n>                      Window

**Parameters:**

<Shape> Shape of the color curve.  
 Range: -1 to 1  
 \*RST: 0

**Manual operation:** See " [Shape](#) " on page 210

**DISPlay[:WINDow<n>]:SGRam:COLor:UPPer** <Percentage>

**DISPlay[:WINDow<n>]:SPECtrogram:COLor:UPPer** <Percentage>

This command defines the end point of the color map.

**Suffix:**

<n> [Window](#)

**Parameters:**

<Percentage> Statistical frequency percentage.  
 Range: 0 to 66  
 \*RST: 0  
 Default unit: %

**Example:**

DISP:WIND:SGR:COL:UPP 95

Sets the start of the color map to 95%.

**Manual operation:** See " [Start / Stop](#) " on page 210

**DISPlay[:WINDow<n>]:SGRam:COLor[:STYLE]** <ColorScheme>

**DISPlay[:WINDow<n>]:SPECtrogram:COLor[:STYLE]** <ColorScheme>

This command selects the color scheme.

**Parameters:**

<ColorScheme> **HOT**  
 Uses a color range from blue to red. Blue colors indicate low levels, red colors indicate high ones.

**COLD**  
 Uses a color range from red to blue. Red colors indicate low levels, blue colors indicate high ones.

**RADar**  
 Uses a color range from black over green to light turquoise with shades of green in between.

**GRAYscale**  
 Shows the results in shades of gray.  
 \*RST: HOT

**Example:**

DISP:WIND:SPEC:COL GRAY

Changes the color scheme of the spectrogram to black and white.

**Manual operation:** See " [Hot / Cold / Radar / Grayscale](#) " on page 211

### 13.7.3.6 Formats for Returned Values: ASCII Format and Binary Format

When trace data is retrieved using the `TRAC:DATA` or `TRAC:IQ:DATA` command, the data is returned in the format defined using the `FORMat[:DATA]`. The possible formats are described here.

- **ASCII Format (FORMat ASCII):**  
The data is stored as a list of comma-separated values (CSV) of the measured values in floating point format.
- **Binary Format (FORMat REAL,32):**  
The data is stored as binary data (Definite Length Block Data according to IEEE 488.2), each measurement value being formatted in 32-Bit IEEE 754 Floating-Point-Format.  
The schema of the result string is as follows:  
`#41024<value1><value2>...<value n>` with

#4	Number of digits (= 4 in the example) of the following number of data bytes
1024	Number of following data bytes (= 1024 in the example)
<Value>	4-byte floating point value



Reading out data in binary format is quicker than in ASCII format. Thus, binary format is recommended for large amounts of data.

## 13.7.4 Markers

- [Individual Marker Configuration](#)..... 524
- [General Marker Configuration](#).....528
- [Marker Search](#).....530
- [Marker Positioning](#)..... 532
- [Marker Results](#)..... 538
- [Spectrogram Markers](#).....540

### 13.7.4.1 Individual Marker Configuration

<code>CALCulate&lt;n&gt;:DELTamarker&lt;m&gt;:AOFF</code> .....	525
<code>CALCulate&lt;n&gt;:DELTamarker&lt;m&gt;:MODE</code> .....	525
<code>CALCulate&lt;n&gt;:DELTamarker&lt;m&gt;:MREF</code> .....	525
<code>CALCulate&lt;n&gt;:DELTamarker&lt;m&gt;[:STATe]</code> .....	526
<code>CALCulate&lt;n&gt;:DELTamarker&lt;m&gt;:TRACe</code> .....	526
<code>CALCulate&lt;n&gt;:DELTamarker&lt;m&gt;:X</code> .....	526
<code>CALCulate&lt;n&gt;:MARKer&lt;m&gt;:AOFF</code> .....	527
<code>CALCulate&lt;n&gt;:MARKer&lt;m&gt;[:STATe]</code> .....	527
<code>CALCulate&lt;n&gt;:MARKer&lt;m&gt;:TRACe</code> .....	527
<code>CALCulate&lt;n&gt;:MARKer&lt;m&gt;:X</code> .....	528

---

**CALCulate<n>:DELTamarker<m>:AOFF**

This command turns off *all* delta markers.

**Suffix:**

<n> [Window](#)

<m> irrelevant

**Example:**

CALC:DELT:AOff

Turns off all delta markers.

**Usage:**

Event

---

**CALCulate<n>:DELTamarker<m>:MODE <Mode>**

This command defines whether the position of a delta marker is provided as an absolute value or relative to a reference marker.

Note that when the position of a delta marker is *queried*, the result is always an absolute value (see [CALCulate<n>:DELTamarker<m>:X](#) on page 526)!

**Suffix:**

<n> [Window](#)

<m> irrelevant

**Parameters:**

<Mode>

**ABSolute**

Delta marker position in absolute terms.

**RELative**

Delta marker position in relation to a reference marker.

\*RST: RELative

**Example:**

CALC:DELT:MODE ABS

Absolute delta marker position.

---

**CALCulate<n>:DELTamarker<m>:MREF <Reference>**

This command selects a reference marker for a delta marker other than marker 1.

**Suffix:**

<n> [Window](#)

<m> [Marker](#)

**Parameters:**

<Reference>

**Example:**

CALC:DELT3:MREF 2

Specifies that the values of delta marker 3 are relative to marker 2.

**Manual operation:** See "[Reference Marker](#)" on page 224

**CALCulate<n>:DELTamarker<m>[:STATe] <State>**

This command turns delta markers on and off.

If necessary, the command activates the delta marker first.

No suffix at DELTmarker turns on delta marker 1.

**Suffix:**

<n> [Window](#)

<m> [Marker](#)

**Parameters:**

<State> ON | OFF | 1 | 0

\*RST: 0

**Example:**

CALC:DELT2 ON

Turns on delta marker 2.

**Manual operation:**

See "[Marker State](#)" on page 223

See "[Marker Type](#)" on page 224

See "[Select Marker](#)" on page 224

**CALCulate<n>:DELTamarker<m>:TRACe <Trace>**

This command selects the trace a delta marker is positioned on.

Note that the corresponding trace must have a trace mode other than "Blank".

If necessary, the command activates the marker first.

**Suffix:**

<n> [Window](#)

<m> [Marker](#)

**Parameters:**

<Trace> Trace number the marker is assigned to.

**Example:**

CALC:DELT2:TRAC 2

Positions delta marker 2 on trace 2.

**CALCulate<n>:DELTamarker<m>:X <Position>**

This command moves a delta marker to a particular coordinate on the x-axis.

If necessary, the command activates the delta marker and positions a reference marker to the peak power.

**Suffix:**

<m> [Marker](#)

<n> [Window](#)

**Example:**

CALC:DELT:X?

Outputs the absolute x-value of delta marker 1.

**Manual operation:** See "[Marker Position X-value](#)" on page 223

#### **CALCulate<n>:MARKer<m>:AOFF**

This command turns off all markers.

**Suffix:**

<n> [Window](#)

<m> [Marker](#)

**Example:**

CALC:MARK:AOFF  
Switches off all markers.

**Usage:** Event

**Manual operation:** See "[All Marker Off](#)" on page 225

#### **CALCulate<n>:MARKer<m>[:STATE] <State>**

This command turns markers on and off. If the corresponding marker number is currently active as a delta marker, it is turned into a normal marker.

**Suffix:**

<n> [Window](#)

<m> [Marker](#)

**Parameters:**

<State> ON | OFF | 1 | 0  
\*RST: 0

**Example:**

CALC:MARK3 ON  
Switches on marker 3.

**Manual operation:** See "[Marker State](#)" on page 223  
See "[Marker Type](#)" on page 224  
See "[Select Marker](#)" on page 224

#### **CALCulate<n>:MARKer<m>:TRACe <Trace>**

This command selects the trace the marker is positioned on.

Note that the corresponding trace must have a trace mode other than "Blank".

If necessary, the command activates the marker first.

**Suffix:**

<n> [Window](#)

<m> [Marker](#)

**Parameters:**

<Trace>

**Example:** //Assign marker to trace 1  
CALC:MARK3:TRAC 2

**Manual operation:** See "[Assigning the Marker to a Trace](#)" on page 224

#### **CALCulate<n>:MARKer<m>:X <Position>**

This command moves a marker to a specific coordinate on the x-axis.

If necessary, the command activates the marker.

If the marker has been used as a delta marker, the command turns it into a normal marker.

**Suffix:**

<m> [Marker](#)

<n> [Window](#)

**Parameters:**

<Position> Numeric value that defines the marker position on the x-axis.  
The unit depends on the result display.

Range: The range depends on the current x-axis range.

**Example:** CALC:MARK2:X 1.7MHz  
Positions marker 2 to frequency 1.7 MHz.

**Manual operation:** See "[Marker Position X-value](#)" on page 223

### 13.7.4.2 General Marker Configuration

<a href="#">CALCulate&lt;n&gt;:MARKer&lt;m&gt;:SCOupled:LSCan</a> .....	528
<a href="#">CALCulate&lt;n&gt;:MARKer&lt;m&gt;:SCOupled[:STATe]</a> .....	529
<a href="#">DISPlay:MINFo[:STATe]</a> .....	529
<a href="#">DISPlay[:WINDow&lt;n&gt;]:MTABLE</a> .....	530

#### **CALCulate<n>:MARKer<m>:SCOupled:LSCan <State>**

This command selects the measurement configuration to be applied when you couple receiver settings to scan range settings.

You can couple the receiver settings to the scan range settings with [CALCulate<n>:MARKer<m>:COUPled\[:STATe\]](#).

**Suffix:**

<m> irrelevant

<n> irrelevant

**Parameters:**

&lt;State&gt;

**ON**

Applies the configuration used during the last scan.

**OFF**

Applies the current configuration.

This has an effect only if you have changed anything since the last scan.

\*RST: OFF

**Example:**

CALC:MARK:COUP ON

CALC:MARK:SCO:LSC ON

Couples the receiver settings to the scan range settings and applies the settings of the last scan.

**Manual operation:** See "[Settings Coupled](#)" on page 226**CALCulate<n>:MARKer<m>:SCOupled[:STATe] <State>**

This command couples or decouples the marker frequency to the scan range settings.

**Suffix:**

&lt;m&gt;

[Marker](#)

&lt;n&gt;

irrelevant

**Parameters:**

&lt;State&gt;

ON | OFF

\*RST: ON

**Example:**

CALC:MARK:SCO ON

Couples the scan range settings to the marker frequency.

**Manual operation:** See "[Settings Coupled](#)" on page 226**DISPlay:MINFo[:STATe] <DisplayMode>**

This command turns the marker information in all diagrams on and off.

**Parameters:**

&lt;DisplayMode&gt;

**ON | 1**

Displays the marker information in the diagrams.

**OFF | 0**

Hides the marker information in the diagrams.

\*RST: 1

**Example:**

DISP:MINF OFF

Hides the marker information.

**Manual operation:** See "[Marker Info](#)" on page 226



**DISPlay[:WINDow<n>]:MTABle <DisplayMode>**

This command turns the marker table on and off.

**Suffix:**

<n> irrelevant

**Parameters:**

<DisplayMode> **ON | 1**  
Turns on the marker table.  
**OFF | 0**  
Turns off the marker table.  
**\*RST: AUTO**

**Example:** DISP:MTAB ON  
Activates the marker table.

**Manual operation:** See "[Marker Table Display](#)" on page 225

**13.7.4.3 Marker Search**

Commands to configure a marker search described elsewhere.

- [CALCulate<n>:MARKer<m>:PEXCursion](#) on page 451

<a href="#">CALCulate&lt;n&gt;:MARKer&lt;m&gt;:COUPlEd[:STATe]</a> .....	530
<a href="#">CALCulate&lt;n&gt;:MARKer&lt;m&gt;:X:SLIMits[:STATe]</a> .....	531
<a href="#">CALCulate&lt;n&gt;:MARKer&lt;m&gt;:X:SLIMits:LEFT</a> .....	531
<a href="#">CALCulate&lt;n&gt;:MARKer&lt;m&gt;:X:SLIMits:RIGHT</a> .....	531
<a href="#">CALCulate&lt;n&gt;:THReshold</a> .....	532
<a href="#">CALCulate&lt;n&gt;:THReshold:STATe</a> .....	532

**CALCulate<n>:MARKer<m>:COUPlEd[:STATe] <State>**

This command couples or decouples the receiver frequency to the current marker frequency.

**Suffix:**

<m> [Marker](#)

<n> irrelevant

**Parameters:**

<State> ON | OFF  
**\*RST: OFF**

**Example:** CALC:MARK:COUP ON  
Couples the frequency to the marker frequency.

**Manual operation:** See "[Synchronizing the receiver frequency to the marker frequency](#)" on page 171

**CALCulate<n>:MARKer<m>:X:SLIMits[:STATe] <State>**

This command turns marker search limits on and off for *all* markers in *all* windows.

**Suffix:**

<n>, <m>                    irrelevant

**Parameters:**

<State>                    ON | OFF | 1 | 0  
\*RST:                    0

**Example:**

CALC:MARK:X:SLIM ON  
Switches on search limitation.

**Manual operation:** See "[Search Limits \( Left / Right \)](#)" on page 227  
See "[Deactivating All Search Limits](#)" on page 228

**CALCulate<n>:MARKer<m>:X:SLIMits:LEFT <SearchLimit>**

This command defines the left limit of the marker search range for *all* markers in *all* windows.

**Suffix:**

<n>, <m>                    irrelevant

**Parameters:**

<SearchLimit>            The value range depends on the frequency range or measurement time.  
The unit is Hz for frequency domain measurements and s for time domain measurements.  
\*RST:                    left diagram border

**Example:**

CALC:MARK:X:SLIM ON  
Switches the search limit function on.  
CALC:MARK:X:SLIM:LEFT 10MHz  
Sets the left limit of the search range to 10 MHz.

**Manual operation:** See "[Search Limits \( Left / Right \)](#)" on page 227

**CALCulate<n>:MARKer<m>:X:SLIMits:RIGHT <SearchLimit>**

This command defines the right limit of the marker search range for *all* markers in *all* windows.

**Suffix:**

<n>, <m>                    irrelevant

**Parameters:**

<Limit>                    The value range depends on the frequency range or measurement time.  
The unit is Hz for frequency domain measurements and s for time domain measurements.  
\*RST:                    right diagram border

**Example:**            `CALC:MARK:X:SLIM ON`  
                          Switches the search limit function on.  
                          `CALC:MARK:X:SLIM:RIGH 20MHz`  
                          Sets the right limit of the search range to 20 MHz.

**Manual operation:** See "[Search Limits \( Left / Right \)](#)" on page 227

#### **CALCulate<n>:THReshold <Level>**

This command defines a threshold level for the marker peak search (for *all* markers in *all* windows).

**Suffix:**  
 <n>                    irrelevant

**Parameters:**  
 <Level>                Numeric value. The value range and unit are variable.  
                          \*RST:                -120 dBm

**Example:**            `CALC:THR -82DBM`  
                          Sets the threshold value to -82 dBm.

**Manual operation:** See "[Search Threshold](#)" on page 228

#### **CALCulate<n>:THReshold:STATe <State>**

This command turns a threshold for the marker peak search on and off (for *all* markers in *all* windows).

**Suffix:**  
 <n>                    irrelevant

**Parameters:**  
 <State>                ON | OFF | 1 | 0  
                          \*RST:                0

**Example:**            `CALC:THR:STAT ON`  
                          Switches on the threshold line.

**Manual operation:** See "[Deactivating All Search Limits](#)" on page 228

### 13.7.4.4 Marker Positioning

- [Markers](#)..... 532
- [Delta Markers](#)..... 535

#### **Markers**

<a href="#">CALCulate&lt;n&gt;:MARKer&lt;m&gt;:MAXimum:LEFT</a> .....	533
<a href="#">CALCulate&lt;n&gt;:MARKer&lt;m&gt;:MAXimum:NEXT</a> .....	533
<a href="#">CALCulate&lt;n&gt;:MARKer&lt;m&gt;:MAXimum[:PEAK]</a> .....	533
<a href="#">CALCulate&lt;n&gt;:MARKer&lt;m&gt;:MAXimum:RIGHT</a> .....	534
<a href="#">CALCulate&lt;n&gt;:MARKer&lt;m&gt;:MINimum:LEFT</a> .....	534

CALCulate<n>:MARKer<m>:MINimum:NEXT.....	534
CALCulate<n>:MARKer<m>:MINimum[:PEAK].....	534
CALCulate<n>:MARKer<m>:MINimum:RIGHT.....	535

---

#### **CALCulate<n>:MARKer<m>:MAXimum:LEFT**

This command moves a marker to the next lower peak.

The search includes only measurement values to the left of the current marker position.

In the spectrogram, the command moves a marker horizontally to the maximum level in the currently selected frame. The vertical marker position remains the same.

##### **Suffix:**

<n>                      Window

<m>                      Marker

**Usage:**                      Event

**Manual operation:**    See " [Search Next Peak](#) " on page 230

---

#### **CALCulate<n>:MARKer<m>:MAXimum:NEXT**

This command moves a marker to the next lower peak.

In the spectrogram, the command moves a marker horizontally to the maximum level in the currently selected frame. The vertical marker position remains the same.

##### **Suffix:**

<n>                      Window

<m>                      Marker

**Usage:**                      Event

**Manual operation:**    See " [Search Next Peak](#) " on page 230

---

#### **CALCulate<n>:MARKer<m>:MAXimum[:PEAK]**

This command moves a marker to the highest level.

In the spectrogram, the command moves a marker horizontally to the maximum level in the currently selected frame. The vertical marker position remains the same.

If the marker is not yet active, the command first activates the marker.

##### **Suffix:**

<n>                      Window

<m>                      Marker

**Usage:**                      Event

**Manual operation:**    See " [Peak Search](#) " on page 230

---

**CALCulate<n>:MARKer<m>:MAXimum:RIGHT**

This command moves a marker to the next lower peak.

The search includes only measurement values to the right of the current marker position.

In the spectrogram, the command moves a marker horizontally to the maximum level in the currently selected frame. The vertical marker position remains the same.

**Suffix:**

<n>                    [Window](#)

<m>                    [Marker](#)

**Usage:**                Event

**Manual operation:**   See "[Search Next Peak](#)" on page 230

---

**CALCulate<n>:MARKer<m>:MINimum:LEFT**

This command moves a marker to the next minimum value.

The search includes only measurement values to the right of the current marker position.

In the spectrogram, the command moves a marker horizontally to the minimum level in the currently selected frame. The vertical marker position remains the same.

**Suffix:**

<n>                    [Window](#)

<m>                    [Marker](#)

**Usage:**                Event

**Manual operation:**   See "[Search Next Minimum](#)" on page 230

---

**CALCulate<n>:MARKer<m>:MINimum:NEXT**

This command moves a marker to the next minimum value.

In the spectrogram, the command moves a marker horizontally to the minimum level in the currently selected frame. The vertical marker position remains the same.

**Suffix:**

<n>                    [Window](#)

<m>                    [Marker](#)

**Usage:**                Event

**Manual operation:**   See "[Search Next Minimum](#)" on page 230

---

**CALCulate<n>:MARKer<m>:MINimum[:PEAK]**

This command moves a marker to the minimum level.

In the spectrogram, the command moves a marker horizontally to the minimum level in the currently selected frame. The vertical marker position remains the same.

If the marker is not yet active, the command first activates the marker.

**Suffix:**

<n> [Window](#)

<m> [Marker](#)

**Usage:** Event

**Manual operation:** See "[Search Minimum](#)" on page 230

**CALCulate<n>:MARKer<m>:MINimum:RIGHT**

This command moves a marker to the next minimum value.

The search includes only measurement values to the right of the current marker position.

In the spectrogram, the command moves a marker horizontally to the minimum level in the currently selected frame. The vertical marker position remains the same.

**Suffix:**

<n> [Window](#)

<m> [Marker](#)

**Usage:** Event

**Manual operation:** See "[Search Next Minimum](#)" on page 230

**Delta Markers**

<a href="#">CALCulate&lt;n&gt;:DELTamarker&lt;m&gt;:MAXimum:LEFT</a> .....	535
<a href="#">CALCulate&lt;n&gt;:DELTamarker&lt;m&gt;:MAXimum:NEXT</a> .....	536
<a href="#">CALCulate&lt;n&gt;:DELTamarker&lt;m&gt;:MAXimum[:PEAK]</a> .....	536
<a href="#">CALCulate&lt;n&gt;:DELTamarker&lt;m&gt;:MAXimum:RIGHT</a> .....	536
<a href="#">CALCulate&lt;n&gt;:DELTamarker&lt;m&gt;:MINimum:LEFT</a> .....	537
<a href="#">CALCulate&lt;n&gt;:DELTamarker&lt;m&gt;:MINimum:NEXT</a> .....	537
<a href="#">CALCulate&lt;n&gt;:DELTamarker&lt;m&gt;:MINimum[:PEAK]</a> .....	537
<a href="#">CALCulate&lt;n&gt;:DELTamarker&lt;m&gt;:MINimum:RIGHT</a> .....	537

**CALCulate<n>:DELTamarker<m>:MAXimum:LEFT**

This command moves a delta marker to the next higher value.

The search includes only measurement values to the left of the current marker position.

In the spectrogram, the command moves a marker horizontally to the maximum level in the currently selected frame. The vertical marker position remains the same.

**Suffix:**

<n> [Window](#)

<m> [Marker](#)

**Usage:** Event

**Manual operation:** See "[Search Next Peak](#)" on page 230

---

#### **CALCulate<n>:DELTamarker<m>:MAXimum:NEXT**

This command moves a marker to the next higher value.

In the spectrogram, the command moves a marker horizontally to the maximum level in the currently selected frame. The vertical marker position remains the same.

**Suffix:**

<n> [Window](#)

<m> [Marker](#)

**Usage:** Event

**Manual operation:** See "[Search Next Peak](#)" on page 230

---

#### **CALCulate<n>:DELTamarker<m>:MAXimum[:PEAK]**

This command moves a delta marker to the highest level.

In the spectrogram, the command moves a marker horizontally to the maximum level in the currently selected frame. The vertical marker position remains the same.

If the marker is not yet active, the command first activates the marker.

**Suffix:**

<n> [Window](#)

<m> [Marker](#)

**Usage:** Event

**Manual operation:** See "[Peak Search](#)" on page 230

---

#### **CALCulate<n>:DELTamarker<m>:MAXimum:RIGHT**

This command moves a delta marker to the next higher value.

The search includes only measurement values to the right of the current marker position.

In the spectrogram, the command moves a marker horizontally to the maximum level in the currently selected frame. The vertical marker position remains the same.

**Suffix:**

<n> [Window](#)

<m> [Marker](#)

**Usage:** Event

**Manual operation:** See "[Search Next Peak](#)" on page 230

---

**CALCulate<n>:DELTaMarker<m>:MINimum:LEFT**

This command moves a delta marker to the next higher minimum value.

The search includes only measurement values to the right of the current marker position.

In the spectrogram, the command moves a marker horizontally to the minimum level in the currently selected frame. The vertical marker position remains the same.

**Suffix:**

<n>                    [Window](#)

<m>                    [Marker](#)

**Usage:**                Event

**Manual operation:**   See "[Search Next Minimum](#)" on page 230

---

**CALCulate<n>:DELTaMarker<m>:MINimum:NEXT**

This command moves a marker to the next higher minimum value.

In the spectrogram, the command moves a marker horizontally to the minimum level in the currently selected frame. The vertical marker position remains the same.

**Suffix:**

<n>                    [Window](#)

<m>                    [Marker](#)

**Usage:**                Event

**Manual operation:**   See "[Search Next Minimum](#)" on page 230

---

**CALCulate<n>:DELTaMarker<m>:MINimum[:PEAK]**

This command moves a delta marker to the minimum level.

In the spectrogram, the command moves a marker horizontally to the minimum level in the currently selected frame. The vertical marker position remains the same.

If the marker is not yet active, the command first activates the marker.

**Suffix:**

<n>                    [Window](#)

<m>                    [Marker](#)

**Usage:**                Event

**Manual operation:**   See "[Search Minimum](#)" on page 230

---

**CALCulate<n>:DELTaMarker<m>:MINimum:RIGHT**

This command moves a delta marker to the next higher minimum value.



The search includes only measurement values to the right of the current marker position.

In the spectrogram, the command moves a marker horizontally to the minimum level in the currently selected frame. The vertical marker position remains the same.

**Suffix:**

<n>                      Window

<m>                      Marker

**Usage:**                Event

**Manual operation:**   See " [Search Next Minimum](#) " on page 230

### 13.7.4.5 Marker Results

Commands to retrieve the marker position described elsewhere.

- [CALCulate<n>:DELTaMarker<m>:X](#) on page 526
- [CALCulate<n>:MARKer<m>:X](#) on page 528

<a href="#">CALCulate&lt;n&gt;:DELTaMarker&lt;m&gt;:X:RELative?</a> .....	538
<a href="#">CALCulate&lt;n&gt;:DELTaMarker&lt;m&gt;:Y?</a> .....	538
<a href="#">CALCulate&lt;n&gt;:MARKer&lt;m&gt;:Y?</a> .....	539

---

#### **CALCulate<n>:DELTaMarker<m>:X:RELative?**

This command queries the relative position of a delta marker on the x-axis.

If necessary, the command activates the delta marker first.

**Suffix:**

<n>                      Window

<m>                      Marker

**Return values:**

<Position>            Position of the delta marker in relation to the reference marker.

**Example:**

`CALC:DELT3:X:REL?`

Outputs the frequency of delta marker 3 relative to marker 1 or relative to the reference position.

**Usage:**                Query only

---

#### **CALCulate<n>:DELTaMarker<m>:Y?**

This command queries the relative position of a delta marker on the y-axis.

If necessary, the command activates the delta marker first.

To get a valid result, you have to perform a complete measurement with synchronization to the end of the measurement before reading out the result. This is only possible for single measurement mode.

The unit depends on the application of the command.

<b>Suffix:</b>	
<m>	Marker
<n>	Window
<b>Return values:</b>	
<Result>	Result at the position of the delta marker. The unit is variable and depends on the one you have currently set.
<b>Example:</b>	<pre>INIT:CONT OFF</pre> <p>Switches to single sweep mode.</p> <pre>INIT;*WAI</pre> <p>Starts a sweep and waits for its end.</p> <pre>CALC:DELT2 ON</pre> <p>Switches on delta marker 2.</p> <pre>CALC:DELT2:Y?</pre> <p>Outputs measurement value of delta marker 2.</p>
<b>Usage:</b>	Query only

---

#### CALCulate<n>:MARKer<m>:Y?

This command queries the position of a marker on the y-axis.

If necessary, the command activates the marker first.

To get a valid result, you have to perform a complete measurement with synchronization to the end of the measurement before reading out the result. This is only possible for single measurement mode.

<b>Suffix:</b>	
<n>	Window
<m>	Marker
<b>Return values:</b>	
<Result>	Result at the marker position. The unit is variable and depends on the one you have currently set.
<b>Example:</b>	<pre>INIT:CONT OFF</pre> <p>Switches to single measurement mode.</p> <pre>CALC:MARK2 ON</pre> <p>Switches marker 2.</p> <pre>INIT;*WAI</pre> <p>Starts a measurement and waits for the end.</p> <pre>CALC:MARK2:Y?</pre> <p>Outputs the measured value of marker 2.</p>
<b>Usage:</b>	Query only

### 13.7.4.6 Spectrogram Markers

#### Marker Configuration

Commands to configure markers in spectrograms described elsewhere.

- `CALCulate<n>:MARKer<m>:MAXimum:LEFT` on page 533
- `CALCulate<n>:MARKer<m>:MAXimum:NEXT` on page 533
- `CALCulate<n>:MARKer<m>:MAXimum[:PEAK]` on page 533
- `CALCulate<n>:MARKer<m>:MAXimum:RIGHT` on page 534
- `CALCulate<n>:MARKer<m>:MINimum:LEFT` on page 534
- `CALCulate<n>:MARKer<m>:MINimum:NEXT` on page 534
- `CALCulate<n>:MARKer<m>:MINimum[:PEAK]` on page 534
- `CALCulate<n>:MARKer<m>:MINimum:RIGHT` on page 535

<code>CALCulate&lt;n&gt;:MARKer&lt;m&gt;:SGRam:FRAME</code> .....	540
<code>CALCulate&lt;n&gt;:MARKer&lt;m&gt;:SPEctrogram:FRAME</code> .....	540
<code>CALCulate&lt;n&gt;:MARKer&lt;m&gt;:SGRam:SARea</code> .....	541
<code>CALCulate&lt;n&gt;:MARKer&lt;m&gt;:SPEctrogram:SARea</code> .....	541
<code>CALCulate&lt;n&gt;:MARKer&lt;m&gt;:SGRam:XY:MAXimum[:PEAK]</code> .....	541
<code>CALCulate&lt;n&gt;:MARKer&lt;m&gt;:SPEctrogram:XY:MAXimum[:PEAK]</code> .....	541
<code>CALCulate&lt;n&gt;:MARKer&lt;m&gt;:SGRam:XY:MINimum[:PEAK]</code> .....	541
<code>CALCulate&lt;n&gt;:MARKer&lt;m&gt;:SPEctrogram:XY:MINimum[:PEAK]</code> .....	541
<code>CALCulate&lt;n&gt;:MARKer&lt;m&gt;:SGRam:Y:MAXimum:ABOVE</code> .....	542
<code>CALCulate&lt;n&gt;:MARKer&lt;m&gt;:SPEctrogram:Y:MAXimum:ABOVE</code> .....	542
<code>CALCulate&lt;n&gt;:MARKer&lt;m&gt;:SGRam:Y:MAXimum:BELOW</code> .....	542
<code>CALCulate&lt;n&gt;:MARKer&lt;m&gt;:SPEctrogram:Y:MAXimum:BELOW</code> .....	542
<code>CALCulate&lt;n&gt;:MARKer&lt;m&gt;:SGRam:Y:MAXimum:NEXT</code> .....	542
<code>CALCulate&lt;n&gt;:MARKer&lt;m&gt;:SPEctrogram:Y:MAXimum:NEXT</code> .....	542
<code>CALCulate&lt;n&gt;:MARKer&lt;m&gt;:SGRam:Y:MAXimum[:PEAK]</code> .....	542
<code>CALCulate&lt;n&gt;:MARKer&lt;m&gt;:SPEctrogram:Y:MAXimum[:PEAK]</code> .....	542
<code>CALCulate&lt;n&gt;:MARKer&lt;m&gt;:SGRam:Y:MINimum:ABOVE</code> .....	543
<code>CALCulate&lt;n&gt;:MARKer&lt;m&gt;:SPEctrogram:Y:MINimum:ABOVE</code> .....	543
<code>CALCulate&lt;n&gt;:MARKer&lt;m&gt;:SGRam:Y:MINimum:BELOW</code> .....	543
<code>CALCulate&lt;n&gt;:MARKer&lt;m&gt;:SPEctrogram:Y:MINimum:BELOW</code> .....	543
<code>CALCulate&lt;n&gt;:MARKer&lt;m&gt;:SGRam:Y:MINimum:NEXT</code> .....	543
<code>CALCulate&lt;n&gt;:MARKer&lt;m&gt;:SPEctrogram:Y:MINimum:NEXT</code> .....	543
<code>CALCulate&lt;n&gt;:MARKer&lt;m&gt;:SGRam:Y:MINimum[:PEAK]</code> .....	544
<code>CALCulate&lt;n&gt;:MARKer&lt;m&gt;:SPEctrogram:Y:MINimum[:PEAK]</code> .....	544

---

**`CALCulate<n>:MARKer<m>:SGRam:FRAME` <Frame> | <Time>**

**`CALCulate<n>:MARKer<m>:SPEctrogram:FRAME` <Frame> | <Time>**

This command positions a marker on a particular frame.

#### Suffix:

<n>                      Window

<m>                      Marker

**Parameters:**

<Frame>	Selects a frame directly by the frame number. Valid if the time stamp is off. The range depends on the history depth.
<Time>	Selects a frame via its time stamp. Valid if the time stamp is on. The number is the (negative) distance to frame 0 in seconds. The range depends on the history depth.

**Example:**

`CALC:MARK:SGR:FRAM -20`  
Sets the marker on the 20th frame before the present.

`CALC:MARK2:SGR:FRAM -2s`  
Sets second marker on the frame 2 seconds ago.

**Manual operation:** See "[Frame \(Spectrogram only\)](#)" on page 224

**CALCulate<n>:MARKer<m>:SGRam:SARea <SearchArea>**

**CALCulate<n>:MARKer<m>:SPECTrogram:SARea <SearchArea>**

This command defines the marker search area for all spectrogram markers in the channel.

**Parameters:**

<SearchArea>	<b>VISible</b> Performs a search within the visible frames. Note that the command does not work if the spectrogram is not visible for any reason (e.g. if the display update is off).
	<b>MEMory</b> Performs a search within all frames in the memory. *RST: VISible

**Manual operation:** See "[Marker Search Area](#)" on page 229

**CALCulate<n>:MARKer<m>:SGRam:XY:MAXimum[:PEAK]**

**CALCulate<n>:MARKer<m>:SPECTrogram:XY:MAXimum[:PEAK]**

This command moves a marker to the highest level of the spectrogram.

**Suffix:**

<n>	<a href="#">Window</a>
<m>	<a href="#">Marker</a>

**Usage:** Event

**CALCulate<n>:MARKer<m>:SGRam:XY:MINimum[:PEAK]**

**CALCulate<n>:MARKer<m>:SPECTrogram:XY:MINimum[:PEAK]**

This command moves a marker to the minimum level of the spectrogram.

**Suffix:**

<n>	<a href="#">Window</a>
<m>	<a href="#">Marker</a>

**Usage:** Event

---

**CALCulate<n>:MARKer<m>:SGRam:Y:MAXimum:ABOVE**  
**CALCulate<n>:MARKer<m>:SPECTrogram:Y:MAXimum:ABOVE**

This command moves a marker vertically to the next lower peak level for the current frequency.

The search includes only frames above the current marker position. It does not change the horizontal position of the marker.

**Suffix:**

<n> Window

<m> Marker

**Usage:** Event

---

**CALCulate<n>:MARKer<m>:SGRam:Y:MAXimum:BELOW**  
**CALCulate<n>:MARKer<m>:SPECTrogram:Y:MAXimum:BELOW**

This command moves a marker vertically to the next lower peak level for the current frequency.

The search includes only frames below the current marker position. It does not change the horizontal position of the marker.

**Suffix:**

<n> Window

<m> Marker

**Usage:** Event

---

**CALCulate<n>:MARKer<m>:SGRam:Y:MAXimum:NEXT**  
**CALCulate<n>:MARKer<m>:SPECTrogram:Y:MAXimum:NEXT**

This command moves a marker vertically to the next lower peak level for the current frequency.

The search includes all frames. It does not change the horizontal position of the marker.

**Suffix:**

<n> Window

<m> Marker

**Usage:** Event

---

**CALCulate<n>:MARKer<m>:SGRam:Y:MAXimum[:PEAK]**  
**CALCulate<n>:MARKer<m>:SPECTrogram:Y:MAXimum[:PEAK]**

This command moves a marker vertically to the highest level for the current frequency.

The search includes all frames. It does not change the horizontal position of the marker.

If the marker hasn't been active yet, the command looks for the peak level in the whole spectrogram.

**Suffix:**

<n> [Window](#)

<m> [Marker](#)

**Usage:** Event

**CALCulate<n>:MARKer<m>:SGRam:Y:MINimum:ABOVE**

**CALCulate<n>:MARKer<m>:SPECTrogram:Y:MINimum:ABOVE**

This command moves a marker vertically to the next higher minimum level for the current frequency.

The search includes only frames above the current marker position. It does not change the horizontal position of the marker.

**Suffix:**

<n> [Window](#)

<m> [Marker](#)

**Usage:** Event

**CALCulate<n>:MARKer<m>:SGRam:Y:MINimum:BELOW**

**CALCulate<n>:MARKer<m>:SPECTrogram:Y:MINimum:BELOW**

This command moves a marker vertically to the next higher minimum level for the current frequency.

The search includes only frames below the current marker position. It does not change the horizontal position of the marker.

**Suffix:**

<n> [Window](#)

<m> [Marker](#)

**Usage:** Event

**CALCulate<n>:MARKer<m>:SGRam:Y:MINimum:NEXT**

**CALCulate<n>:MARKer<m>:SPECTrogram:Y:MINimum:NEXT**

This command moves a marker vertically to the next higher minimum level for the current frequency.

The search includes all frames. It does not change the horizontal position of the marker.

**Suffix:**

<n> [Window](#)

<m>                   Marker  
**Usage:**               Event

---

**CALCulate<n>:MARKer<m>:SGRam:Y:MINimum[:PEAK]**  
**CALCulate<n>:MARKer<m>:SPECTrogram:Y:MINimum[:PEAK]**

This command moves a marker vertically to the minimum level for the current frequency.

The search includes all frames. It does not change the horizontal position of the marker.

If the marker hasn't been active yet, the command first looks for the peak level for all frequencies and moves the marker vertically to the minimum level.

**Suffix:**  
 <n>                   Window  
 <m>                   Marker  
**Usage:**               Event

### Delta Marker Configuration

Commands to configure delta markers in spectrograms described elsewhere.

- [CALCulate<n>:DELTamarker<m>:MAXimum:LEFT](#) on page 535
- [CALCulate<n>:DELTamarker<m>:MAXimum:NEXT](#) on page 536
- [CALCulate<n>:DELTamarker<m>:MAXimum\[:PEAK\]](#) on page 536
- [CALCulate<n>:DELTamarker<m>:MAXimum:RIGHT](#) on page 536
- [CALCulate<n>:DELTamarker<m>:MINimum:LEFT](#) on page 537
- [CALCulate<n>:DELTamarker<m>:MINimum:NEXT](#) on page 537
- [CALCulate<n>:DELTamarker<m>:MINimum\[:PEAK\]](#) on page 537
- [CALCulate<n>:DELTamarker<m>:MINimum:RIGHT](#) on page 537

<a href="#">CALCulate&lt;n&gt;:DELTamarker&lt;m&gt;:SGRam:FRAME</a> .....	545
<a href="#">CALCulate&lt;n&gt;:DELTamarker&lt;m&gt;:SPECTrogram:FRAME</a> .....	545
<a href="#">CALCulate&lt;n&gt;:DELTamarker&lt;m&gt;:SGRam:SARea</a> .....	545
<a href="#">CALCulate&lt;n&gt;:DELTamarker&lt;m&gt;:SPECTrogram:SARea</a> .....	545
<a href="#">CALCulate&lt;n&gt;:DELTamarker&lt;m&gt;:SGRam:XY:MAXimum[:PEAK]</a> .....	546
<a href="#">CALCulate&lt;n&gt;:DELTamarker&lt;m&gt;:SPECTrogram:XY:MAXimum[:PEAK]</a> .....	546
<a href="#">CALCulate&lt;n&gt;:DELTamarker&lt;m&gt;:SGRam:XY:MINimum[:PEAK]</a> .....	546
<a href="#">CALCulate&lt;n&gt;:DELTamarker&lt;m&gt;:SPECTrogram:XY:MINimum[:PEAK]</a> .....	546
<a href="#">CALCulate&lt;n&gt;:DELTamarker&lt;m&gt;:SGRam:Y:MAXimum:ABOVE</a> .....	546
<a href="#">CALCulate&lt;n&gt;:DELTamarker&lt;m&gt;:SPECTrogram:Y:MAXimum:ABOVE</a> .....	546
<a href="#">CALCulate&lt;n&gt;:DELTamarker&lt;m&gt;:SGRam:Y:MAXimum:BELOW</a> .....	546
<a href="#">CALCulate&lt;n&gt;:DELTamarker&lt;m&gt;:SPECTrogram:Y:MAXimum:BELOW</a> .....	546
<a href="#">CALCulate&lt;n&gt;:DELTamarker&lt;m&gt;:SGRam:Y:MAXimum:NEXT</a> .....	547
<a href="#">CALCulate&lt;n&gt;:DELTamarker&lt;m&gt;:SPECTrogram:Y:MAXimum:NEXT</a> .....	547
<a href="#">CALCulate&lt;n&gt;:DELTamarker&lt;m&gt;:SGRam:Y:MAXimum[:PEAK]</a> .....	547
<a href="#">CALCulate&lt;n&gt;:DELTamarker&lt;m&gt;:SPECTrogram:Y:MAXimum[:PEAK]</a> .....	547

CALCulate<n>:DELTamarker<m>:SGRam:Y:MINimum:ABOVe.....	547
CALCulate<n>:DELTamarker<m>:SPECTrogram:Y:MINimum:ABOVe.....	547
CALCulate<n>:DELTamarker<m>:SGRam:Y:MINimum:BELow.....	548
CALCulate<n>:DELTamarker<m>:SPECTrogram:Y:MINimum:BELow.....	548
CALCulate<n>:DELTamarker<m>:SGRam:Y:MINimum:NEXT.....	548
CALCulate<n>:DELTamarker<m>:SPECTrogram:Y:MINimum:NEXT.....	548
CALCulate<n>:DELTamarker<m>:SGRam:Y:MINimum[:PEAK].....	548
CALCulate<n>:DELTamarker<m>:SPECTrogram:Y:MINimum[:PEAK].....	548

---

**CALCulate<n>:DELTamarker<m>:SGRam:FRAME <Frame> | <Time>**

**CALCulate<n>:DELTamarker<m>:SPECTrogram:FRAME <Frame> | <Time>**

This command positions a delta marker on a particular frame. The frame is relative to the position of marker 1.

The command is available for the spectrogram.

**Suffix:**

<n>                      [Window](#)

<m>                      [Marker](#)

**Parameters:**

<Frame>                      Selects a frame directly by the frame number. Valid if the time stamp is off.  
The range depends on the history depth.

<Time>                      Selects a frame via its time stamp. Valid if the time stamp is on.  
The number is the distance to frame 0 in seconds. The range depends on the history depth.

**Example:**

`CALC:DELT4:SGR:FRAM -20`

Sets fourth deltamarker 20 frames below marker 1.

`CALC:DELT4:SGR:FRAM 2 s`

Sets fourth deltamarker 2 seconds above the position of marker 1.

**Manual operation:** See "[Frame \(Spectrogram only\)](#)" on page 224

---

**CALCulate<n>:DELTamarker<m>:SGRam:SARea <SearchArea>**

**CALCulate<n>:DELTamarker<m>:SPECTrogram:SARea <SearchArea>**

This command defines the marker search area for *all* spectrogram markers in the channel.

**Parameters:**

<SearchArea>                      **VISible**

Performs a search within the visible frames.

Note that the command does not work if the spectrogram is not visible for any reason (e.g. if the display update is off).

**MEMory**

Performs a search within all frames in the memory.

\*RST:                      VISible



**Manual operation:** See " [Marker Search Area](#) " on page 229

---

**CALCulate<n>:DELTamarker<m>:SGRam:XY:MAXimum[:PEAK]**  
**CALCulate<n>:DELTamarker<m>:SPECTrogram:XY:MAXimum[:PEAK]**

This command moves a marker to the highest level of the spectrogram over all frequencies.

**Suffix:**

<n> [Window](#)

<m> [Marker](#)

**Usage:** Event

---

**CALCulate<n>:DELTamarker<m>:SGRam:XY:MINimum[:PEAK]**  
**CALCulate<n>:DELTamarker<m>:SPECTrogram:XY:MINimum[:PEAK]**

This command moves a delta marker to the minimum level of the spectrogram over all frequencies.

**Suffix:**

<n> [Window](#)

<m> [Marker](#)

**Usage:** Event

---

**CALCulate<n>:DELTamarker<m>:SGRam:Y:MAXimum:ABOVE**  
**CALCulate<n>:DELTamarker<m>:SPECTrogram:Y:MAXimum:ABOVE**

This command moves a marker vertically to the next higher level for the current frequency.

The search includes only frames above the current marker position. It does not change the horizontal position of the marker.

**Suffix:**

<n> [Window](#)

<m> [Marker](#)

**Usage:** Event

---

**CALCulate<n>:DELTamarker<m>:SGRam:Y:MAXimum:BELOW**  
**CALCulate<n>:DELTamarker<m>:SPECTrogram:Y:MAXimum:BELOW**

This command moves a marker vertically to the next higher level for the current frequency.

The search includes only frames below the current marker position. It does not change the horizontal position of the marker.

**Suffix:**

<n> [Window](#)

<m> [Marker](#)

**Usage:** Event

**CALCulate<n>:DELTamarker<m>:SGRam:Y:MAXimum:NEXT**

**CALCulate<n>:DELTamarker<m>:SPECTrogram:Y:MAXimum:NEXT**

This command moves a delta marker vertically to the next higher level for the current frequency.

The search includes all frames. It does not change the horizontal position of the marker.

**Suffix:**

<n> [Window](#)

<m> [Marker](#)

**Usage:** Event

**CALCulate<n>:DELTamarker<m>:SGRam:Y:MAXimum[:PEAK]**

**CALCulate<n>:DELTamarker<m>:SPECTrogram:Y:MAXimum[:PEAK]**

This command moves a delta marker vertically to the highest level for the current frequency.

The search includes all frames. It does not change the horizontal position of the marker.

If the marker hasn't been active yet, the command looks for the peak level in the whole spectrogram.

**Suffix:**

<n> [Window](#)

<m> [Marker](#)

**Usage:** Event

**CALCulate<n>:DELTamarker<m>:SGRam:Y:MINimum:ABOVE**

**CALCulate<n>:DELTamarker<m>:SPECTrogram:Y:MINimum:ABOVE**

This command moves a delta marker vertically to the next minimum level for the current frequency.

The search includes only frames above the current marker position. It does not change the horizontal position of the marker.

**Suffix:**

<n> [Window](#)

<m> [Marker](#)

**Usage:** Event

**CALCulate<n>:DELTaMarker<m>:SGRam:Y:MINimum:BELOW**  
**CALCulate<n>:DELTaMarker<m>:SPECTrogram:Y:MINimum:BELOW**

This command moves a delta marker vertically to the next minimum level for the current frequency.

The search includes only frames below the current marker position. It does not change the horizontal position of the marker.

**Suffix:**  
 <n>                      Window  
 <m>                      Marker  
**Usage:**                      Event

**CALCulate<n>:DELTaMarker<m>:SGRam:Y:MINimum:NEXT**  
**CALCulate<n>:DELTaMarker<m>:SPECTrogram:Y:MINimum:NEXT**

This command moves a delta marker vertically to the next minimum level for the current frequency.

The search includes all frames. It does not change the horizontal position of the marker.

**Suffix:**  
 <n>                      Window  
 <m>                      Marker  
**Usage:**                      Event

**CALCulate<n>:DELTaMarker<m>:SGRam:Y:MINimum[:PEAK]**  
**CALCulate<n>:DELTaMarker<m>:SPECTrogram:Y:MINimum[:PEAK]**

This command moves a delta marker vertically to the minimum level for the current frequency.

The search includes all frames. It does not change the horizontal position of the marker.

If the marker hasn't been active yet, the command first looks for the peak level in the whole spectrogram and moves the marker vertically to the minimum level.

**Suffix:**  
 <n>                      Window  
 <m>                      Marker  
**Usage:**                      Event

### 13.7.5 Display and Limit Line Configuration

- [Display Lines](#).....549
- [Limit Lines](#).....551

### 13.7.5.1 Display Lines

CALCulate<n>:DLINe<dl>.....	549
CALCulate<n>:DLINe<dl>:STATe.....	549
CALCulate<n>:FLINe<fl>.....	549
CALCulate<n>:FLINe<fl>:STATe.....	550
CALCulate<n>:TFLINe:STATe.....	550
CALCulate<n>:TLINe<tl>.....	550
CALCulate<n>:TLINe<tl>:STATe.....	551

---

#### CALCulate<n>:DLINe<dl> <Position>

This command defines the (vertical) position of a display line.

##### Suffix:

<n>	Window
<dl>	1   2

##### Parameters:

<Position>	The value range is variable. You can use any unit you want, the R&S ESW then converts the unit to the currently selected unit. If you omit a unit, the R&S ESW uses the currently selected unit.  *RST: (state is OFF)
------------	---

##### Example:

CALC:DLIN2 -20dBm  
Positions the second display line at -20 dBm.

**Manual operation:** See " [Horizontal Line 1 / Horizontal Line 2](#) " on page 232

---

#### CALCulate<n>:DLINe<dl>:STATe <State>

This command turns a display line on and off

##### Suffix:

<n>	Window
<dl>	1   2

##### Parameters:

<State>	ON   OFF   1   0 *RST: 0
---------	-----------------------------

##### Example:

CALC:DLIN2:STAT ON  
Turns on display line 2.

---

#### CALCulate<n>:FLINe<fl> <Frequency>

This command defines the position of a frequency line.

##### Suffix:

<n>	Window
-----	--------

<fl> 1 | 2

**Parameters:**

<Frequency>

Note that you can not set a frequency line to a position that is outside the current span.

Range: 0 Hz to Fmax  
\*RST: (STATe to OFF)

**Example:**

CALC:FLIN2 120MHz

Sets frequency line 2 to a frequency of 120 MHz.

**Manual operation:** See "[Vertical Line 1 / Vertical Line 2](#)" on page 232

**CALCulate<n>:FLINe<fl>:STATe <State>**

This command turns a frequency line on and off

**Suffix:**

<n> [Window](#)

<fl> 1 | 2

**Parameters:**

<State> ON | OFF | 1 | 0

\*RST: 0

**Example:**

CALC:FLIN2:STAT ON

Turns frequency line 2 on.

**CALCulate<n>:TFLine:STATe <State>**

This command turns the frequency line representing the current receiver frequency on and off.

**Suffix:**

<n> irrelevant

**Parameters:**

<State> ON | OFF

\*RST: ON

**Example:**

CALC:TFL:STAT ON

Turns on the frequency line.

**Manual operation:** See "[Tuned Frequency](#)" on page 232

**CALCulate<n>:TLINe<tI> <Time>**

This command defines the position of a time line.

**Suffix:**

<n> [Window](#)

<tI> 1 | 2

**Parameters:**

<Time> Note that you can not set a time line to a position that is higher than the current sweep time.

Range: 0 s to 1600 s  
\*RST: (STATe to OFF)

**Example:**

CALC:TLIN 10ms  
Sets the first time line to 10 ms.

**Manual operation:** See " [Vertical Line 1 / Vertical Line 2](#) " on page 232

**CALCulate<n>:TLINe<tl>:STATe <State>**

This command turns a time line on and off

**Suffix:**

<n> [Window](#)

<tl> 1 | 2

**Parameters:**

<State> ON | OFF | 1 | 0

\*RST: 0

**Example:**

CALC:TLIN:STAT ON  
Turns the first time line on.

**13.7.5.2 Limit Lines**

- [Limit Line Management](#)..... 551
- [Limit Line Design](#)..... 556
- [Limit Check](#)..... 564
- [Programming Example: Using Limit Lines](#)..... 564

**Limit Line Management**

CALCulate<n>:LIMit<li>:ACTive?	552
CALCulate<n>:LIMit<li>:CONTRol:OFFSet	552
CALCulate<n>:LIMit<li>:COPY	552
CALCulate<n>:LIMit<li>:DELeTe	553
CALCulate<n>:LIMit<li>:LOWer:OFFSet	553
CALCulate<n>:LIMit<li>:LOWer:STATe	553
CALCulate<n>:LIMit<li>:STATe	554
CALCulate<n>:LIMit<li>:TRACe	554
CALCulate<n>:LIMit<li>:TRACe<t>:CHECK	554
CALCulate<n>:LIMit<li>:UPPer:OFFSet	555
CALCulate<n>:LIMit<li>:UPPer:STATe	555
MMEMory:LOAD<n>:LIMit	556
MMEMory:STORE<n>:LIMit	556

**CALCulate<n>:LIMit<li>:ACTive?**

This command queries the names of *all* active limit lines.

**Suffix:**

<n>, <li>                    irrelevant

**Return values:**

<LimitLines>                String containing the names of all active limit lines in alphabetical order.

**Example:**

CALC:LIM:ACT?

Queries the names of all active limit lines.

**Usage:**

Query only

**Manual operation:** See "[Visibility](#)" on page 238

**CALCulate<n>:LIMit<li>:CONTrol:OFFSet <Offset>**

This command defines an offset for a complete limit line.

Compared to shifting the limit line, an offset does not actually change the limit line definition points.

**Suffix:**

<n>                                irrelevant

<li>                                [Limit line](#)

**Parameters:**

<Offset>                        Numeric value.  
The unit depends on the scale of the x-axis.  
\*RST:                            0

**Manual operation:** See "[X-Offset](#)" on page 239

**CALCulate<n>:LIMit<li>:COPY <Line>**

This command copies a limit line.

**Suffix:**

<n>                                [Window](#)

<li>                                [Limit line](#)

**Parameters:**

<Line>                            **1 to 8**  
number of the new limit line  
**<name>**  
String containing the name of the limit line.

**Example:**            `CALC:LIM1:COPY 2`  
                          Copies limit line 1 to line 2.  
                          `CALC:LIM1:COPY 'FM2'`  
                          Copies limit line 1 to a new line named FM2.

**Manual operation:** See " [Copy Line](#) " on page 239

#### **CALCulate<n>:LIMit<li>:DELEte**

This command deletes a limit line.

**Suffix:**

<n>                    [Window](#)

<li>                   [Limit line](#)

**Usage:**             Event

**Manual operation:** See " [Delete Line](#) " on page 240

#### **CALCulate<n>:LIMit<li>:LOWer:OFFSet <Offset>**

This command defines an offset for a complete lower limit line.

Compared to shifting the limit line, an offset does not actually change the limit line definition points.

**Suffix:**

<n>                    [Window](#)

<li>                   [Limit line](#)

**Parameters:**

<Offset>             Numeric value.

\*RST:                0

Default unit: dB

**Manual operation:** See " [Y-Offset](#) " on page 239

#### **CALCulate<n>:LIMit<li>:LOWer:STATe <State>**

This command turns a lower limit line on and off.

Before you can use the command, you have to select a limit line with [CALCulate<n>:LIMit<li>:NAME](#) on page 561.

**Suffix:**

<n>                    irrelevant

<li>                   [Limit line](#)

**Parameters:**

<State>              ON | OFF | 1 | 0

\*RST:                0



**Manual operation:** See " [Visibility](#) " on page 238

---

### CALCulate<n>:LIMit<li>:STATe <State>

This command turns the limit check for a specific limit line on and off.

To query the limit check result, use `CALCulate<n>:LIMit<li>:FAIL?`.

Note that a new command exists to activate the limit check and define the trace to be checked in one step (see `CALCulate<n>:LIMit<li>:TRACe<t>:CHECK` on page 554).

**Suffix:**

<n> irrelevant

<li> [Limit line](#)

**Parameters:**

<State> ON | OFF | 1 | 0

\*RST: 0

**Example:** `CALC:LIM:STAT ON`  
Switches on the limit check for limit line 1.

**Manual operation:** See " [Disable All Lines](#) " on page 240

---

### CALCulate<n>:LIMit<li>:TRACe <TraceNumber>

This command links a limit line to one or more traces.

Note that this command is maintained for compatibility reasons only. Limit lines no longer need to be assigned to a trace explicitly. The trace to be checked can be defined directly (as a suffix) in the new command to activate the limit check (see `CALCulate<n>:LIMit<li>:TRACe<t>:CHECK` on page 554).

**Suffix:**

<n> [Window](#)

<li> [Limit line](#)

**Example:** `CALC:LIM2:TRAC 3`  
Assigns limit line 2 to trace 3.

---

### CALCulate<n>:LIMit<li>:TRACe<t>:CHECK <State>

This command turns the limit check for a specific trace on and off.

To query the limit check result, use `CALCulate<n>:LIMit<li>:FAIL?`.

Note that this command replaces the two commands from previous signal and spectrum analyzers (which are still supported, however):

- `CALCulate<n>:LIMit<li>:TRACe` on page 554
- `CALCulate<n>:LIMit<li>:STATe` on page 554

**Suffix:**<n> [Window](#)<li> [Limit line](#)<t> [Trace](#)**Parameters:**

&lt;State&gt; ON | OFF | 1 | 0

\*RST: 0

**Example:**

CALC:LIM3:TRAC2:CHEC ON

Switches on the limit check for limit line 3 on trace 2.

**Manual operation:** See "[Traces to be Checked](#)" on page 238**CALCulate<n>:LIMit<li>:UPPer:OFFSet <Offset>**

This command defines an offset for a complete upper limit line.

Compared to shifting the limit line, an offset does not actually change the limit line definition points.

**Suffix:**

&lt;n&gt; irrelevant

<li> [Limit line](#)**Parameters:**

&lt;Offset&gt; Numeric value.

\*RST: 0

Default unit: dB

**Manual operation:** See "[Y-Offset](#)" on page 239**CALCulate<n>:LIMit<li>:UPPer:STATe <State>**

This command turns an upper limit line on and off.

Before you can use the command, you have to select a limit line with [CALCulate<n>:LIMit<li>:NAME](#) on page 561.**Suffix:**

&lt;n&gt; irrelevant

<li> [Limit line](#)**Parameters:**

&lt;State&gt; ON | OFF | 1 | 0

\*RST: 0

**Manual operation:** See "[Visibility](#)" on page 238

**MMEMory:LOAD<n>:LIMit <FileName>**

Loads the limit line from the selected file in .CSV format.

**Parameters:**

<FileName> String containing the path and name of the CSV import file.

**Example:** MMEM:LOAD:LIM 'C:\TEST.CSV'

**Manual operation:** See " [Import](#) " on page 242

**MMEMory:STORe<n>:LIMit <FileName>,<LimitLineName>**

This command exports limit line data to an ASCII (CSV) file.

**Suffix:**

<n> irrelevant

**Parameters:**

<FileName> String containing the path and name of the target file.

<LimitLineName> Name of the limit line to be exported.

**Example:** MMEM:STOR:LIM 'C:\TEST', 'UpperLimitLine'  
Stores the limit line named "UpperLimitLine" in the file  
TEST.CSV.

**Manual operation:** See " [Export](#) " on page 242

**Limit Line Design**

CALCulate<n>:LIMit<li>:COMMeNt.....	557
CALCulate<n>:LIMit<li>:CONTRol[:DATA].....	557
CALCulate<n>:LIMit<li>:CONTRol:DOMain.....	557
CALCulate<n>:LIMit<li>:CONTRol:MODE.....	558
CALCulate<n>:LIMit<li>:CONTRol:SHIFt.....	558
CALCulate<n>:LIMit<li>:CONTRol:SPACing.....	558
CALCulate<n>:LIMit<li>:LOWer[:DATA].....	559
CALCulate<n>:LIMit<li>:LOWer:MARGin.....	559
CALCulate<n>:LIMit<li>:LOWer:MODE.....	559
CALCulate<n>:LIMit<li>:LOWer:SHIFt.....	560
CALCulate<n>:LIMit<li>:LOWer:SPACing.....	560
CALCulate<n>:LIMit<li>:LOWer:THReshold.....	560
CALCulate<n>:LIMit<li>:NAME.....	561
CALCulate<n>:LIMit<li>:UNIT.....	561
CALCulate<n>:LIMit<li>:UPPer[:DATA].....	561
CALCulate<n>:LIMit<li>:UPPer:MARGin.....	562
CALCulate<n>:LIMit<li>:UPPer:MODE.....	562
CALCulate<n>:LIMit<li>:UPPer:SHIFt.....	562
CALCulate<n>:LIMit<li>:UPPer:SPACing.....	563
CALCulate<n>:LIMit<li>:UPPer:THReshold.....	563

---

**CALCulate<n>:LIMit<li>:COMMent <Comment>**

This command defines a comment for a limit line.

**Suffix:**

<n> irrelevant

<li> [Limit line](#)

**Parameters:**

<Comment> String containing the description of the limit line.

**Manual operation:** See "[Comment](#)" on page 241

---

**CALCulate<n>:LIMit<li>:CONTrol[:DATA] <LimitLinePoints>**

This command defines the horizontal definition points of a limit line.

**Suffix:**

<n> irrelevant

<li> [Limit line](#)

**Parameters:**

<LimitLinePoints> Variable number of x-axis values.  
Note that the number of horizontal values has to be the same as the number of vertical values set with [CALCulate<n>:LIMit<li>:LOWer\[:DATA\]](#) or [CALCulate<n>:LIMit<li>:UPPer\[:DATA\]](#). If not, the R&S ESW either adds missing values or ignores surplus values.

\*RST: -

**Manual operation:** See "[Data Points](#)" on page 242

---

**CALCulate<n>:LIMit<li>:CONTrol:DOMain <Type>**

This command selects the domain of the limit line.

**Suffix:**

<n> irrelevant

<li> [Limit line](#)

**Parameters:**

<Type> FREQUENCY | TIME

**FREQUENCY**

For limit lines that apply to a range of frequencies.

**TIME**

For limit lines that apply to a period of time.

\*RST: FREQUENCY

**Example:**

```
CALC:LIM:CONT:DOM FREQ
```

Select a limit line in the frequency domain.

**Manual operation:** See " X-Axis " on page 241

---

#### CALCulate<n>:LIMit<li>:CONTrol:MODE <Mode>

This command selects the horizontal limit line scaling.

**Suffix:**

<n> irrelevant

<li> [Limit line](#)

**Parameters:**

<Mode>

**ABSolute**

Limit line is defined by absolute physical values (Hz or s).

**RELative**

Limit line is defined by relative values related to the center frequency (frequency domain) or the left diagram border (time domain).

\*RST: ABSolute

---

#### CALCulate<n>:LIMit<li>:CONTrol:SHIFt <Distance>

This command moves a complete limit line horizontally.

Compared to defining an offset, this command actually changes the limit line definition points by the value you define.

**Suffix:**

<n> irrelevant

<li> [Limit line](#)

**Parameters:**

<Distance>

Numeric value.

The unit depends on the scale of the x-axis.

**Manual operation:** See " Shift x " on page 242

---

#### CALCulate<n>:LIMit<li>:CONTrol:SPACing <InterpolMode>

This command selects linear or logarithmic interpolation for the calculation of limit lines from one horizontal point to the next.

**Suffix:**

<n> [Window](#)

<li> [Limit line](#)

**Parameters:**

<InterpolMode>

LINear | LOGarithmic

\*RST: LIN

**Example:**

CALC:LIM:CONT:SPAC LIN

**Manual operation:** See " X-Axis " on page 241

---

### CALCulate<n>:LIMit<li>:LOWer[:DATA] <LimitLinePoints>

This command defines the vertical definition points of a lower limit line.

**Suffix:**

<n> irrelevant

<li> [Limit line](#)

**Parameters:**

<LimitLinePoints> Variable number of level values.  
 Note that the number of vertical values has to be the same as the number of horizontal values set with [CALCulate<n>:LIMit<li>:CONTRol\[:DATA\]](#). If not, the R&S ESW either adds missing values or ignores surplus values.

\*RST: Limit line state is OFF

**Manual operation:** See " Data Points " on page 242

---

### CALCulate<n>:LIMit<li>:LOWer:MARGin <Margin>

This command defines an area around a lower limit line where limit check violations are still tolerated.

**Suffix:**

<n> irrelevant

<li> [Limit line](#)

**Parameters:**

<Margin> **numeric value**

\*RST: 0

Default unit: dB

**Manual operation:** See " Margin " on page 241

---

### CALCulate<n>:LIMit<li>:LOWer:MODE <Mode>

This command selects the vertical limit line scaling.

**Suffix:**

<n> [Window](#)

<li> [Limit line](#)

**Parameters:**

&lt;Mode&gt;

**ABSolute**

Limit line is defined by absolute physical values.  
The unit is variable.

**RELative**

Limit line is defined by relative values related to the reference level (dB).

\*RST: ABSolute

**Manual operation:** See " X-Axis " on page 241**CALCulate<n>:LIMit<li>:LOWer:SHIFt <Distance>**

This command moves a complete lower limit line vertically.

Compared to defining an offset, this command actually changes the limit line definition points by the value you define.

**Suffix:**

&lt;n&gt; Window

&lt;li&gt; Limit line

**Parameters:**

&lt;Distance&gt; Defines the distance that the limit line moves.

**Manual operation:** See " Shift y " on page 242**CALCulate<n>:LIMit<li>:LOWer:SPACing <InterpolType>**

This command selects linear or logarithmic interpolation for the calculation of a lower limit line from one horizontal point to the next.

**Suffix:**

&lt;n&gt; Window

&lt;li&gt; Limit line

**Parameters:**

&lt;InterpolType&gt; LINear | LOGarithmic

\*RST: LIN

**Manual operation:** See " Y-Axis " on page 241**CALCulate<n>:LIMit<li>:LOWer:THReshold <Threshold>**

This command defines a threshold for relative limit lines.

The R&S ESW uses the threshold for the limit check, if the limit line violates the threshold.

**Suffix:**

&lt;n&gt; irrelevant

<li> [Limit line](#)

**Parameters:**

<Threshold> Numeric value.  
The unit depends on [CALCulate<n>:LIMit<li>:UNIT](#) on page 561.  
\*RST: -200 dBm

**Manual operation:** See "[Threshold](#)" on page 241

**CALCulate<n>:LIMit<li>:NAME <Name>**

This command selects a limit line that already exists or defines a name for a new limit line.

**Suffix:**

<n> [Window](#)

<li> [Limit line](#)

**Parameters:**

<Name> String containing the limit line name.  
\*RST: REM1 to REM8 for lines 1 to 8

**Manual operation:** See "[Name](#)" on page 240

**CALCulate<n>:LIMit<li>:UNIT <Unit>**

This command defines the unit of a limit line.

**Suffix:**

<n> irrelevant

<li> [Limit line](#)

**Parameters:**

<Unit> If you select dB as the limit line unit, the command automatically turns the limit line into a relative limit line.  
\*RST: DBM

**Manual operation:** See "[Y-Axis](#)" on page 241

**CALCulate<n>:LIMit<li>:UPPer[:DATA] <LimitLinePoints>**

This command defines the vertical definition points of an upper limit line.

**Suffix:**

<n> irrelevant

<li> [Limit line](#)



**Parameters:**

<LimitLinePoints> Variable number of level values.  
 Note that the number of vertical values has to be the same as the number of horizontal values set with `CALCulate<n>:LIMit<li>:CONTRol[:DATA]`. If not, the R&S ESW either adds missing values or ignores surplus values.  
 \*RST: Limit line state is OFF

**Manual operation:** See " [Data Points](#) " on page 242

**CALCulate<n>:LIMit<li>:UPPer:MARGin <Margin>**

This command defines an area around an upper limit line where limit check violations are still tolerated.

**Suffix:**

<n> irrelevant  
 <li> [Limit line](#)

**Parameters:**

<Margin> **numeric value**  
 \*RST: 0  
 Default unit: dB

**Manual operation:** See " [Margin](#) " on page 241

**CALCulate<n>:LIMit<li>:UPPer:MODE <Mode>**

This command selects the vertical limit line scaling.

**Suffix:**

<n> [Window](#)  
 <li> [Limit line](#)

**Parameters:**

<Mode> **ABSolute**  
 Limit line is defined by absolute physical values.  
 The unit is variable.  
**RELative**  
 Limit line is defined by relative values related to the reference level (dB).  
 \*RST: ABSolute

**Manual operation:** See " [X-Axis](#) " on page 241

**CALCulate<n>:LIMit<li>:UPPer:SHIFt <Distance>**

This command moves a complete upper limit line vertically.

Compared to defining an offset, this command actually changes the limit line definition points by the value you define.

**Suffix:**

<n> irrelevant

<li> [Limit line](#)

**Parameters:**

<Distance> Defines the distance that the limit line moves.

**Usage:** Event

**Manual operation:** See "[Shift y](#)" on page 242

**CALCulate<n>:LIMit<li>:UPPer:SPACing <InterpolType>**

This command selects linear or logarithmic interpolation for the calculation of an upper limit line from one horizontal point to the next.

**Suffix:**

<n> [Window](#)

<li> [Limit line](#)

**Parameters:**

<InterpolType> LINear | LOGarithmic

\*RST: LIN

**Manual operation:** See "[Y-Axis](#)" on page 241

**CALCulate<n>:LIMit<li>:UPPer:THReshold <Limit>**

This command defines an absolute limit for limit lines with a relative scale.

The R&S ESW uses the threshold for the limit check, if the limit line violates the threshold.

**Suffix:**

<n> irrelevant

<li> [Limit line](#)

**Parameters:**

<Limit> Numeric value.

The unit depends on [CALCulate<n>:LIMit<li>:UNIT](#) on page 561.

\*RST: -200

Default unit: dBm

**Manual operation:** See "[Threshold](#)" on page 241

**Limit Check**

<a href="#">CALCulate&lt;n&gt;:LIMit&lt;li&gt;:CLEar[:IMMediate]</a> .....	564
<a href="#">CALCulate&lt;n&gt;:LIMit&lt;li&gt;:FAIL?</a> .....	564

**CALCulate<n>:LIMit<li>:CLEar[:IMMediate]**

This command deletes the result of the current limit check.

The command works on *all* limit lines in *all* measurement windows at the same time.

**Suffix:**

<n>, <li>                      irrelevant

**Example:**

`CALC:LIM:CLE`

Deletes the result of the limit check.

**CALCulate<n>:LIMit<li>:FAIL?**

This command queries the result of a limit check in the specified window.

To get a valid result, you have to perform a complete measurement with synchronization to the end of the measurement before reading out the result. This is only possible for single measurement mode.

**Suffix:**

<n>                              [Window](#)

<li>                              [Limit line](#)

**Return values:**

<Result>                      **0**  
                                     PASS  
                                     **1**  
                                     FAIL

**Example:**

`INIT;*WAI`

Starts a new sweep and waits for its end.

`CALC2:LIM3:FAIL?`

Queries the result of the check for limit line 3 in window 2.

**Usage:**

Query only

**Programming Example: Using Limit Lines**

The following examples demonstrate how to work with limit lines in a remote environment.

- [Example: Configuring Limit Lines](#).....564
- [Example: Performing a Limit Check](#).....566

**Example: Configuring Limit Lines**

This example demonstrates how to configure 2 limit lines - an upper and a lower limit - for a measurement in a remote environment.

```

//----- Configuing the limit lines -----
CALC:LIM1:NAME 'FM1'
//Names limit line 1 'FM1'.

CALC:LIM1:CONT:MODE ABS
//Selects absolute scaling for the horizontal axis.
CALC:LIM1:CONT 1 MHz,50MHz,100 MHz,150MHz,200MHz
//Defines 5 horizontal definition points for limit line 1.
CALC:LIM1:UPP:MODE ABS
//Selects an absolute vertical scale for limit line 1.
CALC:LIM1:UNIT DBM
//Selects the unit dBm for limit line 1.
CALC:LIM1:UPP -10,-5,0,-5,-10
//Defines 5 definition points for limit line 1.

CALC:LIM1:UPP:MARG 5dB
//Defines an area of 5 dB around limit line 1 where limit check violations
//are still tolerated.

CALC:LIM1:UPP:SHIF -10DB
//Shifts the limit line 1 by -10 dB.
CALC:LIM1:UPP:OFFS -3dB
//Defines an additional -3 dB offset for limit line 1.

CALC:LIM3:NAME 'FM3'
//Names limit line 3 'FM3'.

CALC:LIM3:LOW:MODE REL
//Selects a relative vertical scale for limit line 3.
CALC:LIM3:UNIT DB

CALC:LIM3:CONT 1 MHz,50MHz,100 MHz,150MHz,200MHz
//Defines 5 horizontal definition points for limit line 3.
CALC:LIM3:LOW -90,-60,-40,-60,-90
//Defines 5 definition points relative to the reference level for limit line 3.

CALC:LIM3:LOW:SHIF 2
//Shifts the limit line 3 by 2dB.
CALC:LIM3:LOW:OFFS 3
//Defines an additional 3 dB offset for limit line 3.

CALC:LIM3:LOW:THR -200DBM
//Defines a power threshold of -200dBm that must be exceeded for limit to be checked

CALC:LIM3:LOW:MARG 5dB
//Defines an area of 5dB around limit line 3 where limit check violations
//are still tolerated.

//----- Storing the limit lines -----
MMEM:SEL:CHAN:LIN:ALL ON

```

```
MMEM:STOR:TYPE CHAN
MMEM:STOR:STAT 1,'LimitLines_FM1_FM3'
```

### Example: Performing a Limit Check

This example demonstrates how to perform a limit check during a basic frequency sweep measurement in a remote environment. The limit lines configured in ["Example: Configuring Limit Lines"](#) on page 564 are assumed to exist and be active.

```
//-----Preparing the instrument -----
*RST
//Resets the instrument
INIT:CONT OFF
//Selects single sweep mode.

//-----Configuring the measurement -----
FREQ:CENT 100MHz
//Defines the center frequency
FREQ:SPAN 200MHz
//Sets the span to 100 MHz on either side of the center frequency.
SENS:SWE:COUN 10
//Defines 10 sweeps to be performed in each measurement.
DISP:TRAC1:Y:RLEV 0dBm
//Sets the reference level to 0 dBm.
TRIG:SOUR IFP
TRIG:LEV:IFP -10dBm
//Defines triggering when the second intermediate frequency rises to a level
//of -10 dBm.

//-----Configuring the Trace-----
DISP:TRAC2 ON
DISP:TRAC2:MODE AVER
DISP:TRAC3 ON
DISP:TRAC3:MODE MAXH
//Configures 3 traces: 1 (default): clear/write; 2: average; 3: max hold

//----- Configuring the limit check -----
MMEM:LOAD:TYPE REPL
MMEM:LOAD:STAT 1,'LimitLines_FM1_FM3'
//Loads the limit lines stored in 'LimitLines_FM1_FM3'
CALC:LIM1:NAME 'FM1'
CALC:LIM1:UPP:STAT ON
//Activates upper limit FM1 as line 1.
CALC:LIM3:NAME 'FM3'
CALC:LIM3:LOW:STAT ON
//Activates lower limit line FM3 as line 3.
CALC:LIM:ACT?
//Queries the names of all active limit lines
//Result: 'FM1,FM3'
CALC:LIM1:TRAC3:CHEC ON
//Activates the upper limit to be checked against trace3 (maxhold trace)
```

```
CALC:LIM3:TRAC2:CHEC ON
//Activates the upper limit to be checked against trace2 (average trace)
CALC:LIM:CLE
//Clears the previous limit check results

//----- Performing the measurement-----
INIT;*WAI
//Initiates a new measurement and waits until the last sweep has finished.

//----- Retrieving limit check results-----

CALC:LIM1:FAIL?
//Queries the result of the upper limit line check
CALC:LIM3:FAIL?
//Queries the result of the lower limit line check
```

## 13.8 Data Management

The commands required to store and load instrument settings and import and export measurement results in a remote environment are described here. The tasks for manual operation are described in [Chapter 10, "Data Management"](#), on page 248.

### Addressing drives

The various drives can be addressed via the "mass storage instrument specifier" <msis> using the conventional Windows syntax. The internal hard disk is addressed by "C:". For details on storage locations refer to [Chapter 10.3.2.2, "Storage Location and Filename"](#), on page 255.

The file names (<FileName> parameter) are given as string parameters enclosed in quotation marks. They also comply with Windows conventions. Windows file names do not distinguish between uppercase and lowercase notation.

### Wildcards

The two characters "\*" and "?" can be used as "wildcards". Wildcards are variables for a selection of several files. The question mark "?" replaces exactly one character, the asterisk replaces any of the remaining characters in the file name. "\*. \*" thus means all files in a directory.

### Path names

Storage locations can be specified either as absolute (including the entire path) or relative paths (including only subfolders of the current folder). Use the `MMEM:CDIR?` query to determine the current folder.



### Secure user mode

In secure user mode, settings that are to be stored on the instrument are stored to volatile memory, which is restricted to 256 MHz. Thus, a "Memory full" error may occur although the hard disk indicates that storage space is still available.

• File Management.....	568
• Items to Store.....	575
• Instrument Setting Management.....	578
• Screenshots and Printouts.....	582
• Test Reports.....	594
• Measurement Result Export.....	606
• Examples: Managing Data.....	607

## 13.8.1 File Management

FORMat[:DATA].....	568
FORMat:DEXPort:DSEPARATOR.....	569
MMEemory:CATalog?.....	569
MMEemory:CATalog:LONG?.....	570
MMEemory:CDIRectory.....	571
MMEemory:COMMent.....	571
MMEemory:COPY.....	571
MMEemory:DATA.....	571
MMEemory:DELeTe.....	572
MMEemory:MDIRectory.....	572
MMEemory:MOVE.....	572
MMEemory:MSIS.....	573
MMEemory:NAME.....	573
MMEemory:NETWork:DISConnect.....	573
MMEemory:NETWork:MAP.....	574
MMEemory:NETWork:UNUSeddrives?.....	574
MMEemory:NETWork:USEDdrives?.....	575
MMEemory:RDIRectory.....	575

### FORMat[:DATA] <Format>

This command selects the data format that is used for transmission of trace data from the R&S ESW to the controlling computer.

Note that the command has no effect for data that you send to the R&S ESW. The R&S ESW automatically recognizes the data it receives, regardless of the format.

For details on data formats see [Chapter 13.7.3.6, "Formats for Returned Values: ASCII Format and Binary Format"](#), on page 524.

**Parameters:**

&lt;Format&gt;

**ASCIi**

ASCIi format, separated by commas.

This format is almost always suitable, regardless of the actual data format. However, the data is not as compact as other formats may be.

**REAL,16**

16-bit floating-point numbers (according to IEEE 754) in the "definite length block format".

Compared to `REAL, 32` format, half as many numbers are returned.

**REAL,32**

32-bit floating-point numbers (according to IEEE 754) in the "definite length block format".

The format setting `REAL` is used for the binary transmission of trace data.

For I/Q data, 8 bytes per sample are returned for this format setting.

**REAL,64**

64-bit floating-point numbers (according to IEEE 754) in the "definite length block format".

Compared to `REAL, 32` format, twice as many numbers are returned.

\*RST: ASCII

**Example:**

```
FORM REAL, 32
```

**FORMat:DEXPort:DSEParator <Separator>**

This command selects the decimal separator for data exported in ASCII format.

**Parameters:**

&lt;Separator&gt;

**COMMa**

Uses a comma as decimal separator, e.g. *4,05*.

**POINt**

Uses a point as decimal separator, e.g. *4.05*.

\*RST: \*RST has no effect on the decimal separator.  
Default is `POINt`.

**Example:**

```
FORM:DEXP:DSEP POIN
```

Sets the decimal point as separator.

**Manual operation:**

See ["Exporting a peak list"](#) on page 123

See ["Decimal Separator"](#) on page 204

**MMEMory:CATalog? <Path>**

This command returns the contents of a particular directory.



**Query parameters:**

<Path> String containing the path and directory  
 If you leave out the path, the command returns the contents of the directory selected with `MMEemory:CDIRectory`.  
 The path may be relative or absolute. Using wildcards (\*) is possible to query a certain type of files only.  
 If you use a specific file as a parameter, the command returns the name of the file if the file is found in the specified directory, or an error if the file is not found ("-256, "File name not found").

**Return values:**

<FileNames> List of file and directory names, separated by commas  
 If no files are found, an error is displayed: "-256, "File name not found"

**Example:**

```
MMEM:CAT? 'C:\R_S\Instr\User\SPOOL?.PNG'
```

Returns all files in C:\R\_S\Instr\User whose names start with SPOOL, have 6 letters and the extension .PNG, e.g.:  
 SPOOL1.PNG, SPOOL2.PNG, SPOOL3.PNG

**Example:**

```
MMEM:CAT? 'C:\R_S\Instr\User\SPOOL6.PNG'
```

Query whether the file 'SPOOL6.PNG' also exists in the directory;  
**Result:**  
 -256, "File name not found;:MMEemory:CATalog?  
 'C:\R\_S\Instr\User\SPOOL6.PNG'

**Usage:** Query only

**Manual operation:** See "[Selecting Storage Location - Drive/ Path/ Files](#)" on page 256

**MMEemory:CATalog:LONG? <Path>**

This command returns the contents of a particular directory with additional information about the files.

**Query parameters:**

<Path> String containing the path and directory.  
 If you leave out the path, the command returns the contents of the directory selected with `MMEemory:CDIRectory`.  
 The path may be relative or absolute. Using wildcards (\*) is possible to query a certain type of files only.

**Return values:**

<UsedDiskSpace> Byte size of all files in the directory.

<FreeDiskSpace> Remaining disk space in bytes.

**<FileInfo>**                    **<NameFileN>,<SuffixFileN>,<SizeFileN>**  
 Describes the individual file.

**<NameFileN>**  
 Name of the file.

**<SuffixFileN>**  
 Type of the file. Possible suffixes are: ASCii, BINary, DIRectory, STAT

**<SizeFileN>**  
 Size of the file in bytes.

**Usage:**                    Query only

---

**MMEMory:CDIRectory** **<Directory>**

This command changes the current directory.

**Parameters:**

**<Directory>**                    String containing the path to another directory.  
 The path may be relative or absolute.

---

**MMEMory:COMMeNt** **<Comment>**

This command defines a comment for the stored settings.

**Parameters:**

**<Comment>**                    String containing the comment.

**Example:**

```
MMEMory:COMMeNt "ACP measurement with Standard Tetra from 23.05."
```

```
MMEMory::MMEMory:STORE1:STATE 1, "ACP_T"
```

As a result, in the selection list for recall settings, the comment "ACP measurement with Standard Tetra from 23.05." is added to the ACP entry.

**Manual operation:**    See "[Comment](#)" on page 256

---

**MMEMory:COpy** **<SourceFile>,<DestinationFile>**

This command copies one or more files to another directory.

**Parameters:**

**<SourceFile>**                    String containing the path and file name of the source file.

**<DestinationFile>**                String containing the path and name of the target file.  
 The path may be relative or absolute.

---

**MMEMory:DATA** **<FileName>,[<Block>]**

This command writes block data into a file. The delimiter must be set to EOI to obtain error-free data transfer.

When you query the contents of a file, you can save them in a file on the remote control computer.

The command is useful for reading stored settings files or trace data from the <instrument> or for transferring them to the <instrument>

**Parameters:**

<FileName>	String containing the path and name of the target file.
<Block>	Data block with the following structure. <b>#</b> Hash sign. <b>&lt;number&gt;</b> Length of the length information. <b>&lt;number&gt;</b> Length information of the binary data (number of bytes). <b>&lt;data&gt;</b> Binary data with the indicated <number> of bytes.

**Example:**

```
MMEM:NAME '\Public\User\Testfile.txt'
Creates a new file called 'testfile.txt'.
MMEM:DATA 'Testfile.txt',#220Contents of the
file
The parameter means:
#2: hash sign and length of the length information (20 bytes = 2
digits)
20: indicates the number of subsequent binary data bytes.
Contents of the file: store 20 binary bytes (characters) to the file.
```

**MMEMory:DELeTe** <FileName>

This command deletes a file.

**Parameters:**

<FileName>	String containing the path and file name of the file to delete. The path may be relative or absolute.
------------	--

**Usage:** Event

**MMEMory:MDIRectory** <Directory>

This command creates a new directory.

**Parameters:**

<Directory>	String containing the path and new directory name The path may be relative or absolute.
-------------	--

**Usage:** Event

**MMEMory:MOVE** <SourceFile>,<NewFileName>

This command moves a file to another directory.

The command also renames the file if you define a new name in the target directory. If you do not include a path for <NewFileName>, the command just renames the file.

**Parameters:**

<SourceFile> String containing the path and file name of the source file.  
 <NewFileName> String containing the path and name of the target file.

**Example:**

```
MMEM:MOVE 'C:\TEST01.CFG', 'SETUP.CFG'
Renames TEST01.CFG in SETUP.CFG in directory C:\.
```

**Usage:**

Event

**MMEMory:MSIS <Device>**

This command selects the default storage device used by all MMEMory commands.

**Parameters:**

<Device> 'A:' | 'C:' | ... | 'Z:'  
 String containing the device drive name  
 \*RST: n.a.

**MMEMory:NAME <FileName>**

This command has several purposes, depending on the context it is used in.

- It creates a new and empty file.
- It defines the file name for screenshots taken with `HCOPY[:IMMEDIATE<device>]`. Note that you have to route the printer output to a file.
- It defines the name and directory of a test report.

**Parameters:**

<FileName> String containing the path and name of the target file.

**Example:**

```
MMEM:NAME 'C:\R_S\Instr\User\PRINT1.BMP'
Selects the file name.
```

**Manual operation:** See "[Configuring and Printing the Test Report](#)" on page 287

**MMEMory:NETWork:DISConnect <Drive>[, <Force>]**

This command disconnects a network drive.

**Parameters:**

<Drive> String containing the drive name.

<Force> 1 | 0 | ON | OFF  
 Optional: determines whether disconnection is forced or not  
**1 | ON**  
 Disconnection is forced.  
**0 | OFF**  
 Disconnect only if not in use.  
 \*RST: 0

**Usage:** Event

**MMEMory:NETWork:MAP** <Drive>, <HostName> [, <UserName>, <Password>][, <Reconnect>]

This command maps a drive to a server or server directory of the network.

Note that you have to allow sharing for a server or folder in Microsoft networks first.

**Parameters:**

<Drive> String containing the drive name or path of the directory you want to map.

<HostName> String containing the host name of the computer or the IP address and the share name of the drive.  
 '<host name or IP address\share name>'

<UserName> String containing a user name in the network.  
 The user name is optional.

<Password> String containing the password corresponding to the <UserName>.  
 The password is optional.

<Reconnect> ON | OFF | 1 | 0  
**ON | 1**  
 Reconnects at logon with the same user name.  
**OFF | 0**  
 Does not reconnect at logon.

**Usage:** Event

**MMEMory:NETWork:UNUSeddrives?**

This command returns a list of unused network drives.

**Return values:**

<DriveName> List of network drives in alphabetically descending order, e.g.  
 'W:,V:,U:,...'

**Usage:** Query only

**MMEMory:NETWork:USEDdrives? <State>**

This command returns a list of all network drives in use.

**Parameters:**

<State>	You do not have to use the parameter. If you do not include the parameter, the command returns a list of all drives in use. This is the same behavior as if you were using the parameter OFF.
<b>ON   1</b>	Returns a list of all drives in use including the folder information.
<b>OFF   0</b>	Returns a list of all drives in use.

**Usage:** Query only

**MMEMory:RDIRECTory <Directory>**

This command deletes the indicated directory.

**Parameters:**

<Directory>	String containing the path of the directory to delete. Note that the directory you want to remove must be empty.
-------------	--

**Usage:** Event

**13.8.2 Items to Store**

The following commands select the items to be included in the configuration file.

Depending on the used command, either the items from the entire instrument (MMEMory:SElect[:ITEM]...), or only those from the currently selected channel (MMEM:SElect:CHANnel[:ITEM]...) are stored.

MMEMory:SElect:CHANnel[:ITEM]:ALL.....	576
MMEMory:SElect[:ITEM]:ALL.....	576
MMEMory:SElect:CHANnel[:ITEM]:DEFault.....	576
MMEMory:SElect[:ITEM]:DEFault.....	576
MMEMory:SElect:CHANnel[:ITEM]:HWSettings.....	576
MMEMory:SElect[:ITEM]:HWSettings.....	576
MMEMory:SElect:CHANnel[:ITEM]:LINes:ALL.....	577
MMEMory:SElect[:ITEM]:LINes:ALL.....	577
MMEMory:SElect:CHANnel[:ITEM]:NONE.....	577
MMEMory:SElect[:ITEM]:NONE.....	577
MMEMory:SElect:CHANnel[:ITEM]:SGRam.....	577
MMEMory:SElect[:ITEM]:SGRam.....	577
MMEMory:SElect:CHANnel[:ITEM]:TRACe[:ACTIve].....	578
MMEMory:SElect[:ITEM]:TRACe[:ACTIve].....	578
MMEMory:SElect:CHANnel[:ITEM]:TRANsducer:ALL.....	578
MMEMory:SElect[:ITEM]:TRANsducer:ALL.....	578

**MMEMory:SElect:CHANnel[:ITEM]:ALL****MMEMory:SElect[:ITEM]:ALL**

This command includes all items when storing or loading a configuration file.

The items are:

- Hardware configuration: `MMEMory:SElect[:ITEM]:HWSettings`
- Limit lines: `MMEMory:SElect[:ITEM]:LINes:ALL`
- Spectrogram data: `MMEMory:SElect[:ITEM]:SGRam`
- Trace data: `MMEMory:SElect[:ITEM]:TRACe[:ACTive]`
- Transducers: `MMEMory:SElect[:ITEM]:TRANsducer:ALL`

**Example:** `M MEM:SEL:ALL`

**Usage:** Event

**Manual operation:** See " [Items:](#) " on page 257

**MMEMory:SElect:CHANnel[:ITEM]:DEFault****MMEMory:SElect[:ITEM]:DEFault**

This command selects the current settings as the only item to store to and load from a configuration file.

**Usage:** Event

**Manual operation:** See " [Items:](#) " on page 257

**MMEMory:SElect:CHANnel[:ITEM]:HWSettings <State>****MMEMory:SElect[:ITEM]:HWSettings <State>**

This command includes or excludes measurement (hardware) settings when storing or loading a configuration file.

Measurement settings include:

- general channel configuration
- measurement hardware configuration including markers
- limit lines  
Note that a configuration may include no more than 8 limit lines. This number includes active limit lines as well as inactive limit lines that were used last. Therefore the combination of inactivate limit lines depends on the sequence of use with `MMEMory:LOAD:STATe`.
- color settings
- configuration for the hardcopy output

**Parameters:**

<State> ON | OFF | 0 | 1  
\*RST: 1

**Example:** `M MEM:SEL:HWS ON`

**Manual operation:** See " [Items:](#) " on page 257

**MMEMory:SElect:CHANnel[:ITEM]:LINes:ALL** <State>

**MMEMory:SElect[:ITEM]:LINes:ALL** <State>

This command includes or excludes all limit lines (active and inactive) when storing or loading a configuration file.

**Parameters:**

<State> ON | OFF | 1 | 0  
\*RST: 0

**Example:** MMEM:SEL:LIN:ALL ON

**Manual operation:** See " [Items:](#) " on page 257

**MMEMory:SElect:CHANnel[:ITEM]:NONE**

**MMEMory:SElect[:ITEM]:NONE**

This command does not include any of the following items when storing or loading a configuration file.

- Hardware configuration: [MMEMory:SElect\[:ITEM\]:HWSettings](#)
- Limit lines: [MMEMory:SElect\[:ITEM\]:LINes:ALL](#)
- Spectrogram data: [MMEMory:SElect\[:ITEM\]:SGRam](#)
- Trace data: [MMEMory:SElect\[:ITEM\]:TRACe\[:ACTive\]](#)
- Transducers: [MMEMory:SElect\[:ITEM\]:TRANsducer:ALL](#)

**Example:** MMEM:SEL:NONE

**Usage:** Event

**Manual operation:** See " [Items:](#) " on page 257

**MMEMory:SElect:CHANnel[:ITEM]:SGRam** <State>

**MMEMory:SElect[:ITEM]:SGRam** <State>

This command includes or excludes spectrogram data when storing or loading a configuration file.

**Parameters:**

<State> ON | OFF | 1 | 0  
\*RST: 0

**Example:** MMEM:SEL:SGR ON  
Adds the spectrogram data to the list of data subsets.

**Manual operation:** See " [Items:](#) " on page 257



---

**MMEMory:SElect:CHANnel[:ITEM]:TRACe[:ACTive] <State>**

**MMEMory:SElect[:ITEM]:TRACe[:ACTive] <State>**

This command includes or excludes trace data when storing or loading a configuration file.

**Parameters:**

<State> ON | OFF | 1 | 0  
 \*RST: 0, i.e. no traces are stored

**Example:** MMEM:SEL:TRAC ON

**Manual operation:** See " [Items:](#) " on page 257

---

**MMEMory:SElect:CHANnel[:ITEM]:TRANsducer:ALL <State>**

**MMEMory:SElect[:ITEM]:TRANsducer:ALL <State>**

This command includes or excludes transducer factors when storing or loading a configuration file.

**Parameters:**

<State> ON | OFF | 1 | 0  
 \*RST: 0

**Example:** MMEM:SEL:TRAN:ALL ON

**Manual operation:** See " [Items:](#) " on page 257

---

### 13.8.3 Instrument Setting Management

<a href="#">MMEMory:CLEar:ALL</a> .....	578
<a href="#">MMEMory:CLEar:STATE</a> .....	579
<a href="#">MMEMory:LOAD:AUTO</a> .....	579
<a href="#">MMEMory:LOAD:STATE</a> .....	579
<a href="#">MMEMory:STORe&lt;n&gt;:STATE</a> .....	580
<a href="#">MMEMory:STORe&lt;n&gt;:STATE:NEXT</a> .....	581
<a href="#">MMEMory:STORe&lt;n&gt;:TYPE</a> .....	581
<a href="#">SYSTEM:PRESet</a> .....	582
<a href="#">SYSTEM:PRESet:CHANnel[:EXEC]</a> .....	582

---

**MMEMory:CLEar:ALL**

This command deletes all <instrument> configuration files in the current directory.

You can select the directory with [MMEMory:CDIRectory](#).

**Example:** MMEM:CLE:ALL

**Usage:** Event

**MMEMory:CLEar:STATe 1,<FileName>**

This command deletes an instrument configuration file.

**Parameters:**

1

<FileName> String containing the path and name of the file to delete.  
The string may or may not contain the file's extension.

**Example:** `MMEM:CLE:STAT 1, 'TEST'`

**Usage:** Event

**MMEMory:LOAD:AUTO 1, 'Factory' | <FileName>**

This command restores an <instrument> configuration and defines that configuration as the default state.

The default state is restored after a preset (*\*RST*) or after you turn on the R&S ESW.

**Parameters:**

1

'Factory' | **'Factory'**  
<FileName> Restores the factory settings as the default state.

**'<file\_name>**

String containing the path and name of the configuration file.  
Note that only *instrument* settings files can be selected for the startup recall function; channel files cause an error.

**Example:** `MMEM:LOAD:AUTO 1, 'C:\R_S\Instr\User\TEST'`

**Usage:** Event

**Manual operation:** See "[Startup Recall](#)" on page 258

**MMEMory:LOAD:STATe 1, <FileName>**

This command restores and activates the <instrument> configuration stored in a \*.dfl file.

Note that files with other formats cannot be loaded with this command.

The contents that are reloaded from the file are defined by the last selection made either in the "Save/Recall" dialogs (manual operation) or through the `MMEMory:SELEct[:ITEM]` commands (remote operation; the settings are identical in both cases).

By default, the selection is limited to the user settings ("User Settings" selection in the dialogs, `HWSettings` in SCPI). The selection is not reset by [Preset] or *\*RST*.

As a consequence, the results of a SCPI script using the `MMEMemory:LOAD:STATe` command without a previous `MMEMemory:SElect[:ITEM]` command may vary, depending on previous actions in the GUI or in previous scripts, even if the script starts with the `*RST` command.

It is therefore recommended that you use the appropriate `MMEMemory:SElect[:ITEM]` command before using `MMEMemory:LOAD:STATe`.

**Parameters:**

1

<FileName> String containing the path and name of the file to load. The string may or may not include the file's extension.

**Example:**

```
MMEM:SEL:ALL
//Save all items (User Settings, All Traces, All Limit Lines) from
the R&S ESW.
MMEM:LOAD:STAT 1, 'C:\R_S\Instr\User\TEST01'
//Reloads all items
In the "Recall" dialog, select only "User Settings" and "All Limit
Lines".
MMEM:LOAD:STAT 1, 'C:\R_S\Instr\User\TEST01'
//Reloads user settings and all limit lines.
*RST
//Reset <instrument>.
MMEM:LOAD:STAT 1, 'C:\R_S\Instr\User\TEST01'
//Selected items are retained. Reloads user settings and all limit
lines.
Restart the <instrument>.
(Switch the [ON/OFF] key off and on).
MMEM:LOAD:STAT 1, 'C:\R_S\Instr\User\TEST01'
// Selected items are set to default. Reloads only the user set-
tings.
```

**Manual operation:** See "[Recall](#)" on page 254  
See "[Recall in New Channel / Recall in Current Channel](#)"  
on page 257

---

**MMEMemory:STORe<n>:STATe 1,<FileName>**

This command saves the current <instrument> configuration in a \*.dfl file.

**Secure User Mode**

In secure user mode, settings that are stored on the instrument are stored to volatile memory, which is restricted to 256 MB. Thus, a "memory limit reached" error can occur although the hard disk indicates that storage space is still available.

To store data permanently, select an external storage location such as a USB memory device.

For details, see [Chapter 2.7, "Protecting Data Using the Secure User Mode"](#), on page 37.

**Suffix:**

<n> irrelevant

**Parameters:**

1

<FileName> String containing the path and name of the target file.  
The file extension is .df1.

**Example:**

```
MME:STOR:STAT 1, 'Save'
```

Saves the current <instrument> settings in the file `Save.dfl`.

**Usage:**

Event

**Manual operation:** See " [Save File](#) " on page 257

**MME:STOR<n>:STAT:NEXT**

This command saves the current <instrument> configuration in a \*.df1 file.

The file name depends on the one you have set with `MME:STOR<n>:STAT`.  
This command adds a consecutive number to the file name.

**Secure User Mode**

In secure user mode, settings that are stored on the instrument are stored to volatile memory, which is restricted to 256 MB. Thus, a "memory limit reached" error can occur although the hard disk indicates that storage space is still available.

To store data permanently, select an external storage location such as a USB memory device.

For details, see [Chapter 2.7, "Protecting Data Using the Secure User Mode"](#), on page 37.

**Suffix:**

<n> irrelevant

**Example:**

```
MME:STOR:STAT 1, 'Save'
```

Saves the current <instrument> settings in the file `Save.dfl`.

```
MME:STOR:STAT:NEXT
```

Saves the current <instrument> settings in the file  
`Save_001.dfl`

```
MME:STOR:STAT:NEXT
```

Saves the current <instrument> settings in the file  
`Save_002.dfl`

**Usage:**

Event

**Manual operation:** See " [Save File](#) " on page 257

**MME:STOR<n>:TYPE <Mode>**

This command defines whether the data from the entire <instrument> or only from the current channel is stored with the subsequent `MME:STOR...` command.

**Suffix:**  
 <n> irrelevant

**Parameters:**  
 <Mode> INSTRument | CHANnel

**INSTRument**  
 Stores data from the entire <instrument>.

**CHANnel**  
 Stores data from an individual channel.

\*RST: INST

**Example:**  
 INST:SEL 'SPECTRUM2'  
 Selects channel 'SPECTRUM2'.  
 MMEM:STOR:TYPE CHAN  
 Specifies that channel data is to be stored.

---

### SYSTem:PRESet

This command presets the R&S ESW.

**Example:** SYST:PRES

**Usage:** Event

---

### SYSTem:PRESet:CHANnel[:EXEC]

This command restores the default <instrument> settings in the current channel.

Use `INST:SEL` to select the channel.

**Example:** INST:SEL 'Spectrum2'  
 Selects the channel for "Spectrum2".  
 SYST:PRES:CHAN:EXEC  
 Restores the factory default settings to the "Spectrum2" channel.

**Usage:** Event

**Manual operation:** See "[Preset Channel](#)" on page 140

## 13.8.4 Screenshots and Printouts

Commands to take and store screenshots described elsewhere.

- [MMEMoRY:NAME](#) on page 573

<a href="#">DISPLay:LOGO</a> .....	583
<a href="#">HCOPy:ABORt</a> .....	583
<a href="#">HCOPy:CMAP&lt;item&gt;:DEFault&lt;colors&gt;</a> .....	583
<a href="#">HCOPy:CMAP&lt;item&gt;:HSL</a> .....	584
<a href="#">HCOPy:CMAP&lt;item&gt;:PDEFined</a> .....	585
<a href="#">HCOPy:CONTent</a> .....	585
<a href="#">HCOPy:DESTInation&lt;device&gt;</a> .....	586

HCOPY:DEvice:COLor.....	586
HCOPY:DEvice:LANGUage<device>.....	587
HCOPY[:IMMediate<device>].....	587
HCOPY[:IMMediate<device>]:NEXT.....	588
HCOPY:ITEM:WINDow:TEXT.....	588
HCOPY:PAGE:COUNT:STATe.....	588
HCOPY:PAGE:MARGin<device>:BOTTom.....	588
HCOPY:PAGE:MARGin<device>:LEFT.....	589
HCOPY:PAGE:MARGin<device>:RIGHT.....	589
HCOPY:PAGE:MARGin<device>:TOP.....	589
HCOPY:PAGE:MARGin<device>:UNIT.....	590
HCOPY:PAGE:ORientation<device>.....	590
HCOPY:PAGE:WINDow<device>:CHANnel:STATe.....	590
HCOPY:PAGE:WINDow<device>:COUNT.....	591
HCOPY:PAGE:WINDow<device>:SCALE.....	591
HCOPY:PAGE:WINDow<device>:STATe.....	592
HCOPY:TDSamp:STATe<device>.....	593
SYSTem:COMMunicate:PRINter:ENUMerate:FIRSt?.....	593
SYSTem:COMMunicate:PRINter:ENUMerate[:NEXT]?.....	593
SYSTem:COMMunicate:PRINter:SELEct<device>.....	594

---

### DISPlay:LOGO <State>

Activates/deactivates the printout of the Rohde & Schwarz company logo at the top of each page.

#### Parameters:

<State>            1 | 0 | ON | OFF  
                       **1 | ON**  
                       Logo is printed.  
                       **0 | OFF**  
                       Logo is not printed.  
                       \*RST:        1

**Example:**            DISP:LOGO OFF

**Manual operation:** See " [Print Logo](#) " on page 272

---

### HCOPY:ABORt

This command aborts a running hardcopy output.

**Example:**            HCOP:ABOR

**Usage:**              Event

---

### HCOPY:CMAP<item>:DEFault<colors>

This command defines the color scheme for print jobs.

For details see " [Print Colors](#) " on page 301.

- Suffix:**  
 <item> Selects the item for which the color scheme is to be defined.  
 For more information see [Chapter 13.9.5.3, "CMAP Suffix Assignment"](#), on page 635.
- <colors> 1...4  
 See table below
- Example:** HCOP:CMAP:DEF2  
 Selects the optimized color set for the color settings of a print-out.
- Usage:** Event
- Manual operation:** See "[Print Colors](#)" on page 301

Gui setting	Description	Remote command
"Screen Colors (Print)"	Selects the current screen colors for the printout. The background is always printed in white and the grid in black.	HCOP:CMAP:DEF1
"Optimized Colors"	Selects an optimized color setting for the printout to improve the visibility of the colors (default setting). Trace 1 is blue, trace 2 black, trace 3 green, and the markers are turquoise. The background is always printed in white and the grid in black.	HCOP:CMAP:DEF2
"User Defined Colors"	Selects the user-defined color setting.	HCOP:CMAP:DEF3
"Screen Colors (Screenshot)"	Selects the current screen colors without any changes for a screenshot.	HCOP:CMAP:DEF4

### HCOPy:CMAP<item>:HSL <Color>

This command selects the color for various screen elements in print jobs.

- Suffix:**  
 <item> Selects the item for which the color scheme is to be defined.  
 For more information see [Chapter 13.9.5.3, "CMAP Suffix Assignment"](#), on page 635.

- Parameters:**  
 <Color>
- hue**
  - tint
  - sat**
  - saturation
  - lum**
  - brightness
- The value range is 0 to 1 for all parameters.

- Example:** HCOP:CMAP2:HSL 0.3,0.8,1.0  
 Changes the grid color

- Manual operation:** See "[Defining User-specific Colors](#)" on page 302

**HCOPy:CMAP<item>:PDEFined <Color>**

This command selects a predefined color for various screen elements in print jobs.

**Suffix:**

<item> Selects the item for which the color scheme is to be defined. For more information see [Chapter 13.9.5.3, "CMAP Suffix Assignment"](#), on page 635.

**Parameters:**

<Color> BLACK | BLUE | BROWn | GREen | CYAN | RED | MAGenta | YELLow | WHITE | DGRAY | LGRAY | LBLUe | LGREen | LCYan | LRED | LMAGenta

**Example:** HCOP:CMAP2:PDEF GRE

**Manual operation:** See "[Predefined Colors](#)" on page 302

**HCOPy:CONTent <ContType>**

This command determines the type of content included in the printout.

This setting is independent of the printing device.

**Parameters:**

<ContType> WINDows | HCOPy

**WINDows**

Includes only the selected windows in the printout. All currently active windows for the current channel (or "MultiView") are available for selection. How many windows are printed on a each page of the printout is defined by [HCOPy:PAGE:WINDow<device>:COUNT](#) on page 591.

This option is not available when copying to the clipboard ([HCOP:DEST 'SYST:COMM:CLIP'](#) or an image file (see [HCOPy:DEvice:LANGuage<device>](#) on page 587).

If the destination is currently set to an image file or the clipboard, it is automatically changed to be a PDF file for the currently selected printing device.

**HCOPy**

Selects all measurement results displayed on the screen for the current channel (or "MultiView"): diagrams, traces, markers, marker lists, limit lines, etc., including the channel bar and status bar, for printout on a single page. Displayed items belonging to the software user interface (e.g. softkeys) are not included. The size and position of the elements in the printout is identical to the screen display.

\*RST: HCOPy



**Example:**

```
HCOP:DEST1 'SYST:COMM:CLIP'
HCOP:CONT WIND
HCOP:DEST1?
//Result: 'MMEM'
HCOP:DEV:LANG1?
//Result: 'PDF'
```

"Print to clipboard" is automatically switched to "print to PDF file" when the contents are switched to "multiple windows".

**Manual operation:** See " [Print Screenshot](#) " on page 271  
See " [Print Multiple Windows](#) " on page 271

---

### HCOPY:DESTination<device> <Destination>

This command selects the destination of a print job.

**Suffix:**

<device>                    1 | 2  
Printing device.

**Parameters:**

<Destination>            **'MMEM'**  
Sends the hardcopy to a file.  
You can select the file name with [MMEMory:NAME](#).  
You can select the file format with [HCOPY:DEvice:LANGUage<device>](#).

**'SYST:COMM:PRIN'**  
Sends the hardcopy to a printer.  
You can select the printer with [SYSTEM:COMMunicate:PRINTer:SElect<device>](#).

**'SYST:COMM:CLIP'**  
Sends the hardcopy to the clipboard.  
The format should be WEMF.

\*RST:            'SYST:COMM:CLIP'

**Manual operation:** See " [Destination](#) " on page 275

---

### HCOPY:DEvice:COLor <State>

This command turns color printing on and off.

**Parameters:**

<State>                    **ON | 1**  
Color printing

**OFF | 0**  
Black and white printing

\*RST:            1

**Example:**                HCOP:DEV:COL ON

**HCOPY:DEVIce:LANGUage<device> <Format>**

This command selects the file format for a print job.

**Suffix:**

<device>                    1 | 2  
Printing device.

**Parameters:**

<Format>                    **GDI**  
Graphics Device Interface  
Default format for output to a printer configured under Windows.  
Must be selected for output to the printer interface.  
Can be used for output to a file. The printer driver configured  
under Windows is used to generate a printer-specific file format.

**DOC | PDF**  
File type for test reports  
Available when `HCOPY:MODE = REPort`.

**BMP | JPG | PNG | PDF | SVG**  
Data format for output to files

**Example:**                    `HCOP:DEV:LANG1 PNG`

**Manual operation:**    See "[Destination](#)" on page 275  
See "[Defining general properties of the test report document](#)"  
on page 283

**HCOPY[:IMMEDIATE<device>]**

This command initiates a print job.

If you are printing to a file, the file name depends on `MMEMoRY:NAME`.

The command also generates a measurement report when you have selected `HCOPY:MODE REPort`. Note that you have to add at least one dataset to the report with `HCOPY:TREPort:NEW` on page 603 or `HCOPY:TREPort:APPend`. Otherwise creating the report results in an error.

**Suffix:**

<device>                    1 | 2  
Printing device.

**Example:**                    `HCOP:MODE REPort`  
`MMEM:NAME 'C:\WooHoo.pdf'`  
`HCOP:DEV:LANG PDF`  
`HCOP:TREP:NEW`  
`HCOP`  
Creates a measurement report (in pdf format).

**Usage:**                    Event

**Manual operation:**    See "[Print](#)" on page 273  
See "[Configuring and Printing the Test Report](#)" on page 287

**HCOPy[:IMMEDIATE<device>]:NEXT**

This command initiates a print job.

If you are printing to a file, the file name depends on [MMEMory:NAME](#). This command adds a consecutive number to the file name.

**Suffix:**

<device>                    1 | 2  
                                  Printing device.

**Usage:**                    Event

**Manual operation:**    See " [Print](#) " on page 273

**HCOPy:ITEM:WINDow:TEXT <Comment>**

This command defines a comment to be added to the printout.

**Parameters:**

<Comment>                    String containing the comment.

**Manual operation:**    See " [Comment](#) " on page 272

**HCOPy:PAGE:COUNT:STATe <State>**

This command includes or excludes the page number for printouts consisting of multiple pages ([HCOP:CONT WIND](#)).

**Parameters:**

<State>                    1 | 0 | ON | OFF  
                                  **1 | ON**  
                                  The page number is printed.  
                                  **0 | OFF**  
                                  The page number is not printed.  
\*RST:                    1

**Example:**                    HCOP:PAGE:COUN:STAT ON

**Manual operation:**    See " [Print Page Count](#) " on page 272

**HCOPy:PAGE:MARGIn<device>:BOTTom <Margin>**

This command defines the margin at the bottom of the printout page on which no elements are printed. The margins are defined according to [HCOPy:PAGE:MARGIn<device>:UNIT](#) on page 590.

**Suffix:**

<device>                    1 | 2  
                                  Printing device.

**Parameters:**

<Margin>                    numeric value  
                                  \*RST:            4.23 mm

**Example:**                    HCOP:PAGE:MARG2:BOTT 2

**Manual operation:**    See " Margins " on page 277

---

**HCOPy:PAGE:MARGin<device>:LEFT <Margin>**

This command defines the margin at the left side of the printout page on which no elements are printed. The margins are defined according to [HCOPy:PAGE:MARGin<device>:UNIT](#) on page 590.

**Suffix:**

<device>                    1 | 2  
                                  Printing device.

**Parameters:**

<Margin>                    numeric value  
                                  \*RST:            4.23 mm

**Example:**                    HCOP:PAGE:MARG2:LEFT 2

**Manual operation:**    See " Margins " on page 277

---

**HCOPy:PAGE:MARGin<device>:RIGHT <Margin>**

This command defines the margin at the right side of the printout page on which no elements are printed. The margins are defined according to [HCOPy:PAGE:MARGin<device>:UNIT](#) on page 590.

**Suffix:**

<device>                    1 | 2  
                                  Printing device.

**Parameters:**

<Margin>                    numeric value  
                                  \*RST:            4.23 mm

**Example:**                    HCOP:PAGE:MARG2:RIGH 2

**Manual operation:**    See " Margins " on page 277

---

**HCOPy:PAGE:MARGin<device>:TOP <Margin>**

This command defines the margin at the top of the printout page on which no elements are printed. The margins are defined according to [HCOPy:PAGE:MARGin<device>:UNIT](#) on page 590.

**Suffix:**

<device>                    1 | 2  
                                  Printing device.

**Parameters:**

<Margin> numeric value  
 \*RST: 4.23 mm

**Example:** HCOP:PAGE:MARG2:TOP 2

**Manual operation:** See " Margins " on page 277

**HCOPy:PAGE:MARGIn<device>:UNIT <Unit>**

This command defines the unit in which the margins for the printout page are configured.

**Suffix:**

<device> 1 | 2  
 Printing device.

**Parameters:**

<Unit> MM | IN  
**MM**  
 millimeters  
**IN**  
 inches  
 \*RST: MM

**Example:** HCOP:PAGE:MARG2:BOTT 2

**Manual operation:** See " Margins " on page 277

**HCOPy:PAGE:ORientation<device> <Orientation>**

The command selects the page orientation of the printout.

The command is only available if the output device is a printer or a PDF file.

**Suffix:**

<device> 1 | 2  
 Printing device.

**Parameters:**

<Orientation> LANDscape | PORTrait  
 \*RST: PORTrait

**Example:** HCOP:DEV:LANG1 PDF  
 HCOP:PAGE:ORI2 LAND

**Manual operation:** See " Orientation " on page 276

**HCOPy:PAGE:WINDow<device>:CHANnel:STATe <ChannelName>, <State>**

This command selects all windows of the specified channel to be included in the printout for HCOP:CONT WIND.

**Suffix:**  
 <device> 1 | 2  
 Printing device.

**Parameters:**  
 <ChannelName> String containing the name of the channel.  
 For a list of available channel types use [INSTRUMENT:LIST?](#) on page 424.

<State> 1 | 0 | ON | OFF  
**1 | ON**  
 The channel windows are included in the printout.  
**0 | OFF**  
 The channel windows are not included in the printout.

\*RST: 1

**Example:**  
 HCOP:CONT WIND  
 HCOP:PAGE:WIND2:CHAN 'IQ Analyzer',0  
 HCOP:PAGE:WIND2:STAT 'IQ Analyzer','1',1  
 Prints only window 1 in the IQ Analyzer channel.

**Manual operation:** See "[Print Multiple Windows](#)" on page 271

#### HCOPy:PAGE:WINDow<device>:COUNT <WinPerPage>

This command defines how many windows are displayed on a single page of the printout for [HCOP:CONT WIND](#).

**Suffix:**  
 <device> 1 | 2  
 Printing device.

**Parameters:**  
 <WinPerPage> integer  
 \*RST: 1

**Example:** HCOP:PAGE:WIND2:COUN 2

**Manual operation:** See "[Windows Per Page](#)" on page 276

#### HCOPy:PAGE:WINDow<device>:SCALE <Mode>

This command determines the scaling of the windows in the printout for [HCOP:CONT WIND](#).

**Suffix:**  
 <device> 1 | 2  
 Printing device.

**Parameters:**

<Mode> 1 | 0 | ON | OFF

**1 | ON**  
Each window is scaled to fit the page size optimally, not regarding the aspect ratio of the original display. If more than one window is printed on one page (see [HCOPY:PAGE:WINDow<device>:COUNT](#) on page 591), each window is printed in equal size.  
("Size to fit")

**0 | OFF**  
Each window is printed as large as possible while maintaining the aspect ratio of the original display.  
("Maintain aspect ratio")

\*RST: 1

**Example:** HCOPY:PAGE:WIND2:SCAL 0

**Manual operation:** See " [Scaling](#) " on page 277

**HCOPY:PAGE:WINDow<device>:STATe** <ChannelName>, <WindowName>,<State>

This command selects the windows to be included in the printout for [HCOPY:CONT WIND](#).

**Suffix:**

<device> 1 | 2  
Printing device.

**Parameters:**

<ChannelName> String containing the name of the channel.  
For a list of available channel types use [INSTrument:LIST?](#) on page 424.

<WindowName> String containing the name of the existing window.  
By default, the name of a window is the same as its index.  
To determine the name and index of all active windows in the active channel, use the [LAYout:CATalog\[:WINDow\]?](#) query.

<State> 1 | 0 | ON | OFF

**1 | ON**  
The window is included in the printout.

**0 | OFF**  
The window is not included in the printout.

\*RST: 1

**Example:** HCOPY:PAGE:WIND2:STAT 'IQ Analyzer','1',1

**Manual operation:** See " [Print Multiple Windows](#) " on page 271

**HCOPY:TDSTamp:STATe<device> <State>**

This command includes or excludes the time and date in the printout.

**Suffix:**

<device>            1 | 2  
Printing device.

**Parameters:**

<State>            1 | 0 | ON | OFF  
**1 | ON**  
The time and date are printed.  
**0 | OFF**  
The time and date are not printed.  
\*RST:            1

**Manual operation:** See " [Print Date and Time](#) " on page 272

**SYSTem:COMMunicate:PRINter:ENUMerate:FIRSt?**

This command queries the name of the first available printer.

To query the name of other installed printers, use `SYSTem:COMMunicate:PRINter:ENUMerate[:NEXT]?`.

**Return values:**

<PrinterName>    String containing the name of the first printer as defined in Windows.  
If the command cannot find a printer, it returns an empty string (' ').

**Usage:**            Query only

**Manual operation:** See " [Printer Name](#) " on page 275

**SYSTem:COMMunicate:PRINter:ENUMerate[:NEXT]?**

This command queries the name of available printers.

You have to use `SYSTem:COMMunicate:PRINter:ENUMerate:FIRSt?` for this command to work properly.

**Return values:**

<PrinterName>    String containing the name of one printer as defined in Windows.  
To get a complete list of printers you have to send this query several times until no more printers could be found. In that case, the return value is an empty string (' '). Further queries after the empty string result in an error.

**Usage:**            Query only

**Manual operation:** See " [Printer Name](#) " on page 275



**SYSTem:COMMunicate:PRINter:SElect<device>** <PrinterName>

This command selects the printer that processes jobs sent by the R&S ESW.

Use `HCOPY:DESTination<device>` to select another output destination.

**Suffix:**

<device> 1 | 2  
Printing device.

**Parameters:**

<PrinterName> String containing the printer name.  
Use

- `SYSTem:COMMunicate:PRINter:ENUMerate:FIRSt?` and
- `SYSTem:COMMunicate:PRINter:ENUMerate[:NEXT]?`

to query all available printers.

\*RST: NONE

**Manual operation:** See " [Printer Name](#) " on page 275

## 13.8.5 Test Reports

Commands to create test reports described elsewhere.

- `HCOPY:DEvice:LANGuage<device>` on page 587
- `HCOPY[:IMMediate<device>]` on page 587
- `MMEMory:NAME` on page 573

<code>HCOPY:MODE</code> .....	595
<code>HCOPY:TREPort:APPend</code> .....	595
<code>HCOPY:TREPort:DESCription</code> .....	595
<code>HCOPY:TREPort:ITEM:DEFault</code> .....	596
<code>HCOPY:TREPort:ITEM:HEADer:LINE&lt;line&gt;:CONTrol</code> .....	596
<code>HCOPY:TREPort:ITEM:HEADer:LINE&lt;line&gt;:TEXT</code> .....	596
<code>HCOPY:TREPort:ITEM:HEADer:LINE&lt;line&gt;:TITLe</code> .....	597
<code>HCOPY:TREPort:ITEM:HEADer:STATe</code> .....	598
<code>HCOPY:TREPort:ITEM:LIST?</code> .....	598
<code>HCOPY:TREPort:ITEM:LOGO</code> .....	598
<code>HCOPY:TREPort:ITEM:LOGO:CONTrol</code> .....	599
<code>HCOPY:TREPort:ITEM:SElect</code> .....	599
<code>HCOPY:TREPort:ITEM:TEMPlate:CATalog?</code> .....	602
<code>HCOPY:TREPort:ITEM:TEMPlate:DELeTe</code> .....	602
<code>HCOPY:TREPort:ITEM:TEMPlate:LOAD</code> .....	602
<code>HCOPY:TREPort:ITEM:TEMPlate:SAVE</code> .....	603
<code>HCOPY:TREPort:NEW</code> .....	603
<code>HCOPY:TREPort:PAGesize</code> .....	603
<code>HCOPY:TREPort:PAGecount:STATe</code> .....	603
<code>HCOPY:TREPort:PCOLors[:STATe]</code> .....	604
<code>HCOPY:TREPort:TDSamp[:STATe]</code> .....	604
<code>HCOPY:TREPort:TEST:REMOve</code> .....	604

HCOPy:TREPort:TEST:REMove:ALL.....	605
HCOPy:TREPort:TITLe.....	605
HCOPy:TREPort:TITLe:STATe.....	606

---

### HCOPy:MODE <Mode>

Selects the output of the `HCOPy[:IMMediate<device>]` command.

#### Parameters:

<Mode>	<b>SCReen</b> HCOPy:IMMediate prints the current screen contents.
	<b>REPort</b> HCOPy:IMMediate generates a measurement report.
	*RST: SCReen

#### Example:

```
HCOP:MODE REPort
HCOP
```

Creates a file containing the measurement report.

**Manual operation:** See "[Configuring and Printing the Test Report](#)" on page 287

---

### HCOPy:TREPort:APPend

This command adds the current measurement results to the test report.

The saved data depends on the items you have selected with `HCOPy:TREPort:ITEM:SElect` on page 599.

#### Example:

Perform a measurement, then:

```
HCOP:TREP:NEW
```

Creates a new test report with the results of the first measurement.

Perform another measurement, then:

```
HCOP:TREP:APP
```

Adds the results of the second measurement to the test report.

#### Usage:

Event

**Manual operation:** See "[Adding and Removing Datasets](#)" on page 287

---

### HCOPy:TREPort:DESCription <Description>

This command defines the description of the test report as shown on its title page.

#### Parameters:

<Description>	String containing the description of the test report.
---------------	---

#### Example:

```
HCOP:TREP:DESC 'A short summary of the test report.'
```

Adds a description to the test report.

**Manual operation:** See "[Defining the contents of the title page](#)" on page 285

---

**HCOPy:TREPort:ITEM:DEFault**

This command restores the default configuration of the test report regarding the information that is part of the report.

It also restores the default names of the measurement information titles.

**Example:** `HCOP:TREP:ITEM:DEF`  
Restores the default test report configuration.

**Usage:** Event

**Manual operation:** See ["Selecting the Test Report Contents"](#) on page 283  
See ["Managing Templates"](#) on page 286

---

**HCOPy:TREPort:ITEM:HEADer:LINE<line>:CONTrol <Repetition>**

This command selects how often the items in the report header are displayed in the document.

**Suffix:**  
<line> 1...6  
Selects the header line.

**Parameters:**  
<Repetition>

**GLOBAL**  
The selected header line is displayed at the top of every page of the report.

**NEVer**  
The selected header line is displayed on no page of the report. Note that a line that does not contain anything is still displayed in the report as a blank line. If you select NEVer, the line is not displayed at all.

**SECTIon**  
The selected header line is displayed after the title of every sub-report.

\*RST: NEVer

**Example:** `HCOP:TREP:ITEM:HEAD:LINE4:TITL ''`  
`HCOP:TREP:ITEM:HEAD:LINE4:TEXT ''`  
Defines an empty string for line 4 of the report header.  
`HCOP:TREP:ITEM:HEAD:LINE4:CONT NEV`  
Removes line 4 from the header of the test report.

**Manual operation:** See ["Adding custom information about the measurement"](#) on page 284

---

**HCOPy:TREPort:ITEM:HEADer:LINE<line>:TEXT <Description>**

This command defines a descriptive text for one of the items part of the report header.

You can define up to 6 items in the header.

Use `HCOPY:TREPort:ITEM:HEADer:LINE<line>:TITLe` on page 597 to define custom titles for each item.

Use `HCOPY:TREPort:ITEM:HEADer:LINE<line>:CONTrol` to select the condition under which each item is shown.

**Suffix:**

<line> 1...6  
Selects the header line.

**Parameters:**

<Description> String containing the description of one of the value fields.  
By default, the value fields of the items are empty.

**Example:**

```
HCOP:TREP:ITEM:HEAD:LINE3:TITL 'Device under
Test'
```

Renames the third title into "Device under Test".

```
HCOP:TREP:ITEM:HEAD:LINE3:TEXT 'Some Device'
```

Labels the third title as "Some Device".

**Manual operation:** See ["Adding custom information about the measurement"](#) on page 284

**HCOPY:TREPort:ITEM:HEADer:LINE<line>:TITLe <Title>**

This command defines a custom name for one of the items part of the report header.

You can define up to 6 items in the header.

Use `HCOPY:TREPort:ITEM:HEADer:LINE<line>:TEXT` to add a value to each item.

Use `HCOPY:TREPort:ITEM:HEADer:LINE<line>:CONTrol` to select the condition under which each item is shown.

**Suffix:**

<line> 1...6  
Selects the header line.

**Parameters:**

<Title> String containing the title of the item.  
The default titles are as follows:

- Line 1: "Heading"
- Line 2: "Meas Type"
- Line 3: "Equipment under Test"
- Line 4: "Manufacturer"
- Line 5: "OP Condition"
- Line 6: "Test Spec"

Make sure that the title string is not too long, because strings that are too long could mess up the layout of the report.

**Example:**

```
HCOP:TREP:ITEM:HEAD:LINE3:TITL 'Device under
Test'
```

Renames the third title into "Device under Test".

**Manual operation:** See ["Adding custom information about the measurement"](#) on page 284

---

### HCOPY:TREPort:ITEM:HEADer:STATe <State>

This command includes or excludes the complete set of measurement information from the test report.

**Parameters:**

<State> ON | OFF  
\*RST: ON

**Example:** HCOPY:TREP:ITEM:HEAD:STAT ON  
Includes the measurement information in the test report.

**Manual operation:** See ["Adding custom information about the measurement"](#) on page 284

---

### HCOPY:TREPort:ITEM:LIST? [<ChannelType>]

This command queries the selected information to be included in the test report for a specific channel type.

**Parameters:**

<ChannelType> Selects the channel type that you want to query the test report configuration for.  
When you omit the parameter, the command returns the configuration of the currently selected channel.

**Example:** HCOPY:TREP:ITEM:LIST? SAN  
Queries the items that are included in the test reports of the Spectrum application.

**Usage:** Query only

*Table 13-5: Available <ChannelTypes>*

<ChannelType>	
CAPD	CISPR APD
IQ	I/Q Analyzer
REC	Receiver
RTIM	Real-Time
SAN	Spectrum

---

### HCOPY:TREPort:ITEM:LOGO <FileName>

This command selects a graphic (for example a company logo) that is shown at the top of each page in the test report.

Use `HCOPy:TREPort:ITEM:LOGO:CONTRol` on page 599 to select the conditions under which the picture is shown.

**Parameters:**

<FileName> String containing the location and name of the picture. You can use the following file types: bmp, jpg, png, gif, emf or wmf format.

**Example:**

```
HCOP:TREP:ITEM:LOGO 'C:\aPicture.jpg'
```

Includes a picture at the top of each page of the report.

**Manual operation:**

See ["Adding custom information about the measurement"](#) on page 284

**HCOPy:TREPort:ITEM:LOGO:CONTRol <Repetition>**

This command selects how often the logo is displayed in the document.

**Parameters:**

<Repetition>

**GLOBAL**

The selected header line is displayed at the top of every page of the report.

**NEVer**

The selected header line is displayed on no page of the report. Note that a line that does not contain anything is still displayed in the report as a blank line. If you select NEVer, the line is not displayed at all.

```
*RST:      NEVer
```

**Example:**

```
HCOP:TREP:ITEM:LOGO 'c:\logo.png'
```

Selects a picture to be displayed in the report document.

```
HCOP:TREP:ITEM:LOGO:CONT SECT
```

Displays the logo after each subreport.

**Manual operation:**

See ["Adding custom information about the measurement"](#) on page 284

**HCOPy:TREPort:ITEM:SELEct [<ChannelType>,'<Item>,<Item>,<Item>,...'**

This command defines the type of information that a test report is made up out of.

**Parameters:**

<ChannelType>

Optional parameter to define the channel type that the selection applies to.

When you omit the <ChannelType> parameter, the selection applies to the currently active channel.

<Item> String containing the information you want to include in the test report.  
 Note that the items, separated by commas, have to be written into one string (see example below).  
 The available items depend on the application you are using. See the tables below for a short description of each item.  
 Per default, some items are selected (see tables below).

**Example:** `HCOP:TREP:ITEM:SEL 'SETT,MARK,SRES,DIAG'`  
 Each dataset consists of the measurement settings, marker information, the scan results and a screenshot of the scan trace (for Receiver channels).  
 The selection is applied to the currently selected channel.

**Example:** `HCOP:TREP:ITEM:SEL REC,'BARG,LISN'`  
 A dataset in the Receiver application consists of the bargraph and the LISN settings.

**Manual operation:** See ["Selecting the Test Report Contents"](#) on page 283

**Table 13-6: Available <ChannelTypes>**

<ChannelType>	Description
ADEM	Analog demodulator
CAPD	CISPR APD
IQ	I/Q analyzer
REC	Receiver
RTIM	Real-time
SAN	Spectrum

**Table 13-7: Available <items> in receiver application**

<Item>	Description	Default
BARGraph	Screenshot of the bargraph.	
DIAGram	Screenshot of the scan results.	x
FRESults	Numerical results for the final measurement.	
IF	Screenshot of the results for IF analysis.	x
IFSPectrogram	Screenshot of the IF spectrogram.	x
LISN	Information about LISNs.	
MARKers	Contents of the marker table.	x
PRESults	Contents of the peak list.	
SCANtable	Measurement configuration as defined in the scan table.	
SETTings	Settings that have been used during a measurement.	x
SPECTrogram	Screenshot of the spectrogram.	x

<Item>	Description	Default
SRESults	Numerical results for the scan.	
TRANsducer	Characteristics of the transducer.	

**Table 13-8: Available <items> in CISPR APD application**

<Item>	Description	Default
DIAGram	Screenshot of the measurement results.	x
MARKers	Contents of the marker table.	x
SPECtrogram	Screenshot of the spectrogram.	x
RSUMMary	Contents of the result summary.	x
TRANsducer	Characteristics of the transducer.	

**Table 13-9: Available <items> in spectrum application**

<Item>	Description	Default
DIAGram	Screenshot of the scan results.	x
MARKers	Contents of the marker table.	x
PEAKlist	Contents of the peak list.	x
RESultlist	Numerical measurement results.	
RSUMmary	Contents of the result summary.	x
SETTings	Settings that have been used during a measurement.	x
SPECtrogram	Screenshot of the spectrogram.	x
TRANsducer	Characteristics of the transducer.	

**Table 13-10: Available <items> in I/Q analyzer**

<Item>	Description	Default
DIAGram	Screenshot of the result diagram.	x
FREQuency	Screenshot of the Spectrum results.	x
MAGNitude	Screenshot of the Magnitude results.	x
PEAKlist	Contents of the peak list.	x
RESultlist	Numerical measurement results.	x
RIMag	Screenshot of the Real / Imaginary results.	x
SETTings	Settings that have been used during a measurement.	x
TRANsducer	Characteristics of the transducer.	
VECTor	Screenshot of the I/Q Vector results.	x



Table 13-11: Available &lt;items&gt; in real-time application

<Item>	Description	Default
PSPepectrum	Screenshot of the persistence spectrum.	x
RESultlist	Numerical measurement results.	x
SETTings	Settings that have been used during a measurement.	x
SGRam	Screenshot of the spectrogram.	x
SPECtrum	Screenshot of the real-time spectrum.	x
TRANsducer	Characteristics of the transducer.	

---

### HCOPy:TREPort:ITEM:TEMPlate:CATalog?

This command queries the test report templates available in the default report directory (and its subdirectories).

**Return values:**

<Templates> String containing the name of the templates as a comma-separated list.

**Example:**

```
HCOP:TREP:ITEM:TEMP:CAT?
would return, e.g.:
'TemplateX, TemplateY, TemplateZ'
```

**Usage:**

Query only

**Manual operation:** See "[Managing Templates](#)" on page 286

---

### HCOPy:TREPort:ITEM:TEMPlate:DELeTe <Template>

This command deletes a test report template.

**Parameters:**

<Template> String containing the name of the template.

**Example:**

```
HCOP:TREP:ITEM:TEMP:DEL 'myTemplate'
Deletes a test report template.
```

**Usage:**

Event

---

### HCOPy:TREPort:ITEM:TEMPlate:LOAD <Template>

This command loads a test report template.

**Parameters:**

<Template> String containing the name of the template.

**Example:**

```
HCOP:TREP:ITEM:TEMP:LOAD 'myTemplate'
Loads a test report template.
```

**Usage:**

Event

**Manual operation:** See "[Managing Templates](#)" on page 286

---

**HCOPy:TREPort:ITEM:TEMPlate:SAVE** <Template>

This command saves a test report template.

**Parameters:**

<Template>                      String containing the name of the template.

**Example:**                      HCOP:TREP:ITEM:TEMP:SAVE 'myTemplate'  
Saves a test report template.

**Usage:**                          Event

**Manual operation:**    See ["Managing Templates"](#) on page 286

---

**HCOPy:TREPort:NEW**

This command creates a new test report.

Creating a test report deletes all previously saved datasets. The current measurement results are added as the first dataset to the new report.

The R&S ESW saves the data selected with [HCOPy:TREPort:ITEM:SElect](#) on page 599.

**Example:**                      HCOP:TREP:NEW  
Creates a test report.

**Usage:**                          Event

**Manual operation:**    See ["Adding and Removing Datasets"](#) on page 287

---

**HCOPy:TREPort:PAGesize** <Size>

This command selects the size of the test report document.

**Parameters:**

<Size>                              **A4**  
Document pages have an A4 size.  
**US**  
Document pages have a US letter size.  
**\*RST:**                      A4

**Example:**                      HCOP:TREP:PAG A4  
Selects the A4 size for the document.

**Manual operation:**    See ["Defining general properties of the test report document"](#) on page 283

---

**HCOPy:TREPort:PAGecount:STATe** <State>

This command includes or excludes page number from the test report.

**Parameters:**

<State> ON | OFF  
\*RST: ON

**Example:**

HCOP:TREP:PAG:STAT OFF  
Removes page numbers from the test report.

**Manual operation:** See ["Defining general properties of the test report document"](#) on page 283

---

**HCOPy:TREPort:PCOLors[:STATE] <State>**

This command turns the use of printer friendly colors on and off.

**Parameters:**

<State> ON | OFF  
\*RST: OFF

**Example:**

HCOP:TREP:PCOL ON  
Creates the test report with printer friendly colors.

**Manual operation:** See ["Defining general properties of the test report document"](#) on page 283

---

**HCOPy:TREPort:TDSTamp[:STATE] <State>**

This command includes or excludes date and time from the test report.

**Parameters:**

<State> ON | OFF  
\*RST: ON

**Example:**

HCOP:TREP:TDST OFF  
Does not show any time or date information in the test report.

**Manual operation:** See ["Defining general properties of the test report document"](#) on page 283

---

**HCOPy:TREPort:TEST:REMOve <Dataset>**

This command deletes one of the datasets that are currently part of a test report.

Note that the command only deletes datasets as a whole (= complete chapters). Deleting individual items of a dataset is not possible.

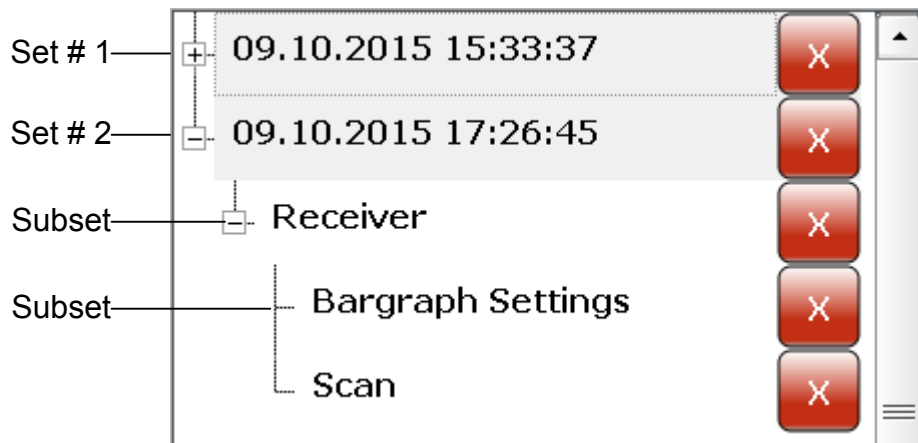

Set # 1 = Number of the dataset would be "1".  
 Set # 2 = Number of the dataset would be "2".  
 Subset = Cannot be removed.

**Parameters:**

&lt;Dataset&gt;

Index number of the dataset as shown in the "Test Report Content Selection" dialog box.  
 If the index number is greater than the number of available datasets, the command returns an error.

**Example:**

```
HCOP:TREP:TEST:REM 2
```

Deletes the second dataset from the current test report.

**Manual operation:** See ["Adding and Removing Datasets"](#) on page 287

**HCOPy:TREPort:TEST:REMOve:ALL**

This command removes all existing datasets from the test report.

**Example:**

```
HCOP:TREP:TEST:REM:ALL
```

Deletes all datasets that are currently in the test report.

**Usage:**

Event

**Manual operation:** See ["Adding and Removing Datasets"](#) on page 287

**HCOPy:TREPort:TITLe <Title>**

This command defines the title for the test report as shown on its title page.

**Parameters:**

&lt;Title&gt;

String containing the title.

**Example:**

```
HCOP:TREP:TITL 'My first test report'
```

Defines a title for a test report.

**Manual operation:** See ["Defining the contents of the title page"](#) on page 285

**HCOPy:TREPort:TITLe:STATe <State>**

This command includes or excludes the title page from the test report.

**Parameters:**

<State>                    ON | OFF  
 \*RST:                    OFF

**Example:**

HCOP:TREP:TITL:STAT OFF  
 Removes the title page from the test report.

**Manual operation:** See ["Defining the contents of the title page"](#) on page 285

## 13.8.6 Measurement Result Export

Commands to export measurement results described elsewhere.

- [FORMat \[ : DATA \]](#) on page 568

<a href="#">MMEMory:STORe&lt;n&gt;:SGRam</a> .....	606
<a href="#">MMEMory:STORe&lt;n&gt;:SPECTrogram</a> .....	606
<a href="#">MMEMory:STORe&lt;n&gt;:TRACe</a> .....	607

**MMEMory:STORe<n>:SGRam <FileName>****MMEMory:STORe<n>:SPECTrogram <FileName>**

This command exports spectrogram data to an ASCII file.

The file contains the data for every frame in the history buffer. The data corresponding to a particular frame begins with information about the frame number and the time that frame was recorded.

Note that, depending on the size of the history buffer, the process of exporting the data can take a while.

**Secure User Mode**

In secure user mode, settings that are stored on the instrument are stored to volatile memory, which is restricted to 256 MB. Thus, a "memory limit reached" error can occur although the hard disk indicates that storage space is still available.

To store data permanently, select an external storage location such as a USB memory device.

For details, see [Chapter 2.7, "Protecting Data Using the Secure User Mode"](#), on page 37.

**Suffix:**

<n>                    [Window](#)

**Parameters:**

<FileName>            String containing the path and name of the target file.

**Example:**

MMEM:STOR:SGR 'Spectrogram'  
 Copies the spectrogram data to a file.

**MMEMory:STORe<n>:TRACe <Trace>, <FileName>**

This command exports trace data from the specified window to an ASCII file.

For details on the file format see [Chapter 9.3.8.1, "Reference: ASCII File Export Format"](#), on page 216.

**Secure User Mode**

In secure user mode, settings that are stored on the instrument are stored to volatile memory, which is restricted to 256 MB. Thus, a "memory limit reached" error can occur although the hard disk indicates that storage space is still available.

To store data permanently, select an external storage location such as a USB memory device.

For details, see [Chapter 2.7, "Protecting Data Using the Secure User Mode"](#), on page 37.

**Suffix:**

<n> [Window](#)

**Setting parameters:**

<Trace> Number of the trace to be stored

<FileName> String containing the path and name of the target file.

**Example:**

MMEM:STOR1:TRAC 1, 'C:\TEST.ASC'  
Stores trace 1 from window 1 in the file TEST.ASC.

**Usage:**

Setting only

**Manual operation:** See "[Export Trace to ASCII File](#)" on page 205

**13.8.7 Examples: Managing Data**

- [Storing Data](#)..... 607
- [Loading Data](#)..... 608
- [Storing Instrument Settings](#)..... 608
- [Loading Instrument Settings](#)..... 609
- [Printing to a File](#)..... 609
- [Printing on a Printer](#)..... 609

**13.8.7.1 Storing Data**

```
MMEM:MSIS 'C:'
//Selects drive C: as the default storage device.
-----Connecting a network drive-----
MMEM:NETW:USED?
//Returns a list of all drives in use in the network.
MMEM:NETW:UNUS?
//Returns a list of free drive names in the network.
MMEM:NETW:MAP 'T:', 'Server\ACLRTTest'
//Maps drive T: to the directory 'Server\ACLRTTest'
```

```

-----Saving data on the instrument-----
MMEM:MDIR 'C:\R_S\INST\USER\ACLRTTest'
//Creates a directory called 'ACLRTTest' on drive C:
MMEM:NAME 'C:\R_S\INST\USER\Test001.txt'
//Creates a file called 'Test001.txt'
MMEM:COMM 'ACLR test results'
//Creates a comment for the file.
MMEM:DATA 'Test001.txt',#212FileContents
//Writes 12 characters to the file 'Test001.txt'
-----Copying the data to another location---
MMEM:COPY 'C:\R_S\INST\USER\Results\Test001.txt','T:'
//Copies the specified file to network drive T:.
MMEM:DEL 'C:\R_S\INST\USER\Results\Test001.txt'
//Deletes the specified file from the instrument hard disk.
//or
MMEM:MOVE 'C:\R_S\INST\USER\Results\Test001.xml','D:\TestResults.txt'//
//Moves the file 'Test001.txt' to drive T:, renames it to 'Testresults.txt'
//and removes it from the instrument hard disk.
MMEM:RDIR 'C:\R_S\INST\USER\Results'
//Deletes the directory called 'Results' from drive C:, unless it still contains any content.
-----Disconnecting the network drive---
MMEM:NETW:DISC 'T:'
//Disconnect drive T:.

```

### 13.8.7.2 Loading Data

```

MMEM:CDir?
//Returns the path of the current directory.
//e.g.
C:\R_S\Instr\user\
MMEM:CDir 'C:\R_S\INST\USER\Results'
//Changes the current directory.
MMEM:CAT? 'C:\R_S\INST\USER\Results\*.xml'
//or
MMEM:CAT? '*.xml'
//Returns a list of all xml files in the directory 'C:\R_S\INST\USER\Results'.
MMEM:CAT:LONG? '*.xml'
//Returns additional information about the xml files in the directory 'C:\R_S\INST\USER\Results'.

```

### 13.8.7.3 Storing Instrument Settings

In this example we will store the instrument settings for the "Spectrum" channel.

```

INST:SEL 'SPECTRUM'
//Selects measurement channel 'SPECTRUM'.
MEMM:STOR:TYPE CHAN
//Specifies that channel-specific data is to be stored.
MMEM:STOR:STAT 1, 'C:\R_S\Instr\user\Spectrum'

```

```
//Stores the channel settings from the 'Spectrum' channel
// to the file 'Spectrum.dfl'.
```

#### 13.8.7.4 Loading Instrument Settings

In this example we will load the hardware settings from the configuration file `Spectrum.dfl` to a new "Spectrum2" channel.

```
MEMM:LOAD:TYPE NEW
//Specifies that settings will be loaded to a new channel besides the existing
//'Spectrum' channel.
MEMM:SEL:CHAN:HWS ON
//Selects only hardware settings to be loaded.
MEMM:LOAD:STAT 1, 'C:\R_S\Instr\user\Spectrum'
//Loads the channel-specific settings from the file 'C:\R_S\Instr\user\Spectrum.dfl'
//to a new channel. The new channel is named 'Spectrum2' to avoid a naming conflict
//with the existing 'Spectrum' channel.
INST:REN 'Spectrum2','Spectrum3'
//Renames the loaded channel to 'Spectrum3'.
```

#### 13.8.7.5 Printing to a File

```
HCOP:DEST 'MEMM'
//Prints the data to a file.
HCOP:DEV:LANG BMP
//Selects bmp as the file format.
MEMM:NAME 'C:\R_S\INST\USER\Screenshot.bmp'
//Selects the file name for the printout.
HCOP:ITEM:ALL
//Prints all screen elements
HCOP:ITEM:WIND:TEXT 'ACLRResults'
//Adds a comment to the printout.
HCOP
//Stores the printout in a file called 'Screenshot.bmp'.
HCOP:NEXT
//Stores the printout in a file called 'Screenshot_001.bmp'.
```

#### 13.8.7.6 Printing on a Printer

```
HCOP:DEST2 'SYST:COMM:PRIN'
//Prints the data on a printer.
SYST:COMM:PRIN:ENUM:FIRS?
SYST:COMM:PRIN:ENUM?
//Returns the available printers, e.g.
'LASER on LPT1'
''
//Means that one printer is available.
SYST:COMM:PRIN:SEL2 'LASER on LPT1'
//Selects the printer for the print job on device 2.
```



```

HCOP:PAGE:ORI2 LAND
//Selects the landscape format for the printout.
HCOP:TDST:STAT2 ON
//Includes date and time on the printout.
HCOP:ITEM:ALL
//Prints all screen elements
HCOP
//Initiates the printout.

```

## 13.9 General Instrument Setup

- [Basic Instrument Setup](#)..... 610
- [Reference Frequency Configuration](#)..... 611
- [Calibration and Temperature Check](#)..... 614
- [Transducers](#)..... 618
- [Display Layout and Elements](#)..... 629
- [Measurement Channel Synchronization](#)..... 637
- [Network and Remote Control Configuration](#)..... 649
- [System Configuration Check](#)..... 656
- [Service Functions](#)..... 662

### 13.9.1 Basic Instrument Setup

<a href="#">SYSTem:CLOGging</a> .....	610
<a href="#">SYSTem:REBoot</a> .....	610
<a href="#">SYSTem:SHUTdown</a> .....	611

---

#### SYSTem:CLOGging <State>

This command turns logging of remote commands on and off.

##### Parameters:

<State>

**ON | 1**

Writes all remote commands that have been sent to a file.

The destination is C:

\R\_S\INSTR\ScpiLogging\ScpiLog.<no.>.

where <no.> is a sequential number

A new log file is started each time logging was stopped and is restarted.

**OFF | 0**

\*RST: 0

**Manual operation:** See "[I/O Logging](#)" on page 390

---

#### SYSTem:REBoot

This command reboots the instrument, including the operating system.

**Usage:** Event

---

### SYSTem:SHUTdown

This command shuts down the R&S ESW.

**Usage:** Event

## 13.9.2 Reference Frequency Configuration

[SENSe:]ROSCillator:LBWidth.....	611
[SENSe:]ROSCillator:O100.....	611
[SENSe:]ROSCillator:O640.....	612
SOURce:EXTernal:ROSCillator:EXTernal:FREQuency.....	612
[SENSe:]ROSCillator:OSYNc.....	612
[SENSe:]ROSCillator:SOURce.....	612
[SENSe:]ROSCillator:SOURce:EAUTO?.....	613
[SENSe:]ROSCillator:TRANge.....	614

---

### [SENSe:]ROSCillator:LBWidth <Bandwidth>

Defines the loop bandwidth, that is, the speed of internal synchronization with the reference frequency. The setting requires a compromise between performance and increasing phase noise.

For a variable external reference frequency with a narrow tuning range (+/- 0.5 ppm), the loop bandwidth is fixed to 0.1 Hz and cannot be changed.

**Parameters:**

<Bandwidth> 0.1 Hz | 1 Hz | 3 Hz | 10 Hz | 30 Hz | 100 Hz | 300 Hz  
 The possible values depend on the reference source and tuning range (see [Table 11-2](#)).  
 Default unit: Hz

**Example:** ROSC:LBW 3

**Manual operation:** See "[Loop Bandwidth](#)" on page 322

---

### [SENSe:]ROSCillator:O100 <State>

If enabled, a 100 MHz reference signal is provided to the "REF OUTPUT 100 MHz" connector.

**Parameters:**

<State> ON | OFF | 1 | 0  
 \*RST: 0

**Example:** ROSC:O100 ON

**Manual operation:** See "[Reference Frequency Output](#)" on page 322

---

**[SENSe:]ROSCillator:O640 <State>**

If enabled, a 640 MHz reference signal is provided to the "REF OUTPUT 640 MHz" connector.

**Parameters:**

<State>                    ON | OFF | 1 | 0  
\*RST:                    0

**Example:**                ROSC:O640 ON

**Manual operation:**    See ["Reference Frequency Output"](#) on page 322

---

**SOURce:EXTernal:ROSCillator:EXTernal:FREQUENCY <Frequency>**

This command defines the frequency of the external reference oscillator.

If the external reference oscillator is selected, the reference signal must be connected to the rear panel of the instrument.

**Parameters:**

<Frequency>              Range:        1 MHz to 20 MHz

**Example:**                ROSC:EXT:FREQ 13MHZ  
Sets the frequency to 13 MHz.  
SOUR:EXT:ROSC:EXT:FREQ 13MHZ

**Manual operation:**    See ["Reference Frequency Input"](#) on page 320

---

**[SENSe:]ROSCillator:OSYNc <State>**

If enabled, a 100 MHz reference signal is provided to the "SYNC TRIGGER OUTPUT" connector.

**Parameters:**

<State>                    ON | OFF | 1 | 0  
\*RST:                    0

**Example:**                ROSC:OSYN ON

**Manual operation:**    See ["Reference Frequency Output"](#) on page 322

---

**[SENSe:]ROSCillator:SOURce <Source>**

This command selects the reference oscillator.

If you want to select the external reference, it must be connected to the R&S ESW.

**Parameters:**

&lt;Source&gt;

**INTernal**

The internal reference is used (10 MHz)

**EXTernal | EXTernal1 | EXT1**

The external reference from the "REF INPUT 10 MHZ" connector is used; if none is available, an error flag is displayed in the status bar

**E10**

The external reference from "REF INPUT 1..20 MHZ" connector is used with a fixed 10 MHz frequency; if none is available, an error flag is displayed in the status bar

**E100**

The external reference from the "REF INPUT 100 MHZ" connector is used with a fixed 100 MHz frequency; if none is available, an error flag is displayed in the status bar

**EAUTO**

The external reference is used as long as it is available, then the instrument switches to the internal reference

**SYNC**

The external reference is used; if none is available, an error flag is displayed in the status bar

**Example:**

ROSC:SOUR EXT

**Manual operation:**See ["Reference Frequency Input"](#) on page 320See ["Behavior in case of missing external reference"](#) on page 321**[SENSe:]ROSCillator:SOURce:EAUTO?**

This command queries the current reference type in case you have activated an automatic switch to the internal reference if the external reference is missing.

**Parameters:**

&lt;Reference&gt;

**INT**

internal reference

**EXT**

external reference

**Example:**

SENS:ROSC:SOUR:EAUT?

Queries the currently available reference type.

**Usage:**

Query only

**Manual operation:**See ["Behavior in case of missing external reference"](#) on page 321

**[SENSe:]ROSCillator:TRANge <Range>**

Defines the tuning range. The tuning range is only available for the variable external reference frequency. It determines how far the frequency may deviate from the defined level in parts per million ( $10^{-6}$ ).

**Parameters:**

<Range> The possible values depend on the reference source (see [Table 11-2](#)).

**SMALI**

With this smaller deviation ( $\pm 0.5$  ppm) a very narrow fixed loop bandwidth of 0.1 Hz is realized. With this setting the instrument can synchronize to an external reference signal with a very precise frequency. Due to the very narrow loop bandwidth, unwanted noise or spurious components on the external reference input signal are strongly attenuated. Furthermore, the loop requires about 30 seconds to reach a locked state. During this locking process, "NO REF" is displayed in the status bar.

**WIDE**

The larger deviation ( $\pm 6$  ppm) allows the instrument to synchronize to less precise external reference input signals.

**Example:** ROSC:TRAN WIDE

**Manual operation:** See "Tuning Range" on page 321

### 13.9.3 Calibration and Temperature Check

CALibration[:ALL]?	614
CALibration:RESult?	615
DIAGnostic:SERVice:INPut:MC[:DISTance]	615
DIAGnostic:SERVice:INPut:PULSed:CFRequency	615
DIAGnostic:SERVice:INPut:RF[:SPEctrum]	616
DIAGnostic:SERVice:INPut[:SELect]	616
DIAGnostic:SERVice:INPut:SYNThtwo[:FREQuency]	616
DIAGnostic:SERVice:STESt:RESult?	617
SOURce:TEMPerature:FRONtend?	617

**CALibration[:ALL]?**

This command initiates a calibration (self-alignment) routine and queries if calibration was successful.

During the acquisition of correction data the instrument does not accept any remote control commands.

**Note:** If you start a self-alignment remotely, then select the "Local" softkey while the alignment is still running, the instrument only returns to the manual operation state after the alignment is completed.

In order to recognize when the acquisition of correction data is completed, the MAV bit in the status byte can be used. If the associated bit is set in the Service Request Enable (SRE) register, the instrument generates a service request after the acquisition of correction data has been completed.

**Return values:**

<CalibrationState> **0**  
The command returns a '0' if calibration was successful.

**Example:**

```
*CLS
Resets the status management.
*SRE 16
Enables MAV bit in the Service Request Enable register.
*CAL?
Starts the correction data recording, and then a service request
is generated.
```

**Usage:** Query only

**Manual operation:** See "[Start Self Alignment](#)" on page 292

**CALibration:RESult?**

This command returns the results collected during calibration.

**Return values:**

<CalibrationData> String containing the calibration data.

**Example:**

```
CAL:RES?
would return, e.g.
Total Calibration Status:
PASSED, Date (dd/mm/yyyy): 12/07/2004,
Time: 16:24:54, Runtime: 00.06
```

**Usage:** Query only

**Manual operation:** See "[Alignment Results:](#)" on page 293

**DIAGnostic:SERVice:INPut:MC[:DISTance] <Bandwidth>**

This command selects the distance of the peaks of the microwave calibration signal for calibration of the YIG filter.

**Parameters:**

<Bandwidth> **SMALI**  
Small offset of combine frequencies.  
**WIDE**  
Wide offset of combine frequencies.

**DIAGnostic:SERVice:INPut:PULSed:CFrequency <Frequency>**

This command defines the frequency of the calibration signal.

Before you can use the command, you have to feed in a calibration signal with `DIAGnostic:SERVice:INPut[:SElect]`.

**Parameters:**

<Frequency> Possible frequencies of the calibration signal are fixed. If you define a frequency that is not available, the R&S ESW uses the next available frequency. Example: a frequency of 20 MHz is rounded up to the next available frequency (21.33 MHz).

\*RST: 64 MHz

Default unit: Hz

**Manual operation:** See " [Calibration Frequency RF](#) " on page 332

**DIAGnostic:SERVice:INPut:RF[:SPECTrum]** <Bandwidth>

This command selects the bandwidth of the calibration signal.

**Parameters:**

<Bandwidth> **NARRowband**  
Narrowband signal for power calibration of the frontend.

**BROadband**  
Broadband signal for calibration of the IF filter.

**Manual operation:** See " [Spectrum](#) " on page 332

**DIAGnostic:SERVice:INPut[:SElect]** <Signal>

This command activates or deactivates the use of an internal calibration signal as input for the R&S ESW.

**Parameters:**

<Signal> **CALibration**  
Uses the calibration signal as RF input.

**MCALibration**  
Uses the calibration signal for the microwave range as RF input.

**RF**  
Uses the signal from the RF input.

\*RST: RF

**Example:** `DIAG:SERV:INP CAL`  
Uses the calibration signal as RF input.

**Manual operation:** See " [NONE](#) " on page 332  
See " [Calibration Frequency RF](#) " on page 332  
See " [Calibration Frequency MW](#) " on page 332

**DIAGnostic:SERVice:INPut:SYNThtwo[:FREQuency]** <Frequency>

This command selects the frequency which the synthesizers are calibrated for.

The command is available when you select the synthesizer as the calibration source with `DIAGnostic:SERVice:INPut[:SELect]` on page 616.

**Parameters:**

<Frequency>            <numeric value>  
                               Default unit: Hz

**Example:**

```
DIAG:SERV:INP:SEL SYNT
DIAG:SERV:INP:SYNT 10MHZ
```

**DIAGnostic:SERVice:STEST:RESult?**

This command queries the self-test results.

**Return values:**

<Results>                String of data containing the results.  
                               The rows of the self-test result table are separated by commas.

**Example:**

```
DIAG:SERV:STES:RES?
would return, e.g.
"Total Selftest Status:
PASSED", "Date (dd/mm/yyyy): 09/07/2004 TIME:
16:24:54", "Runtime: 00:06", "...
```

**Usage:**

Query only

**SOURce:TEMPerature:FRONtend?**

This command queries the current frontend temperature of the R&S ESW.

During self-alignment, the instrument's (frontend) temperature is also measured (as soon as the instrument has warmed up completely). This temperature is used as a reference for a continuous temperature check during operation. If the current temperature deviates from the stored self-alignment temperature by a certain degree, a warning is displayed in the status bar indicating the resulting deviation in the measured power levels. A status bit in the `STATUS:QUESTionable:TEMPerature` register indicates a possible deviation.

**Return values:**

<Temperature>            Temperature in degrees Celsius.

**Example:**

```
SOUR:TEMP:FRON?
Queries the temperature of the frontend sensor.
```

**Usage:**

Query only



## 13.9.4 Transducers



Before making any changes to a transducer factor or set, you have to select one by name with `[SENSe:]CORRection:TSET:SElect`.

Compared to manual configuration of transducers, any changes made to a transducer factor or set via remote control are saved after the corresponding command has been sent.

### Designing a transducer factor

```
//Select a transducer factor
CORR:TRAN:SEL 'Transducer1'
//Define a comment for the transducer factor
CORR:TRAN:COMM 'Correction values for device x'
//Define the transducer factor unit
CORR:TRAN:UNIT 'DB'
//Select the scale of the frequency axis
CORR:TRAN:SCAL LOG
//Define the data points of the transducer factor
CORR:TRAN:DATA 1MHZ,-10,10MHZ,-10,100MHZ,-15,1GHZ,-15
//Turn on the transducer
CORR:TRAN ON
//Automatically adjust the reference level
CORR:TRAN:ADJ:RLEV ON
```

### Managing a transducer set

```
//Select or create a transducer set
CORR:TSET:SEL 'Transducer Set'
//Define a comment for the transducer set
CORR:TSET:COMM 'Transducer set example'
//Define a unit for the transducer set
CORR:TSET:UNIT 'DB'
//Turn the transducer break on
CORR:TSET:BRE ON
//Define the first transducer range
CORR:TSET:RANG1 150KHZ,1MHZ,'Transducer 1','Transducer 3'
CORR:TSET:RANG2 1MHZ,10MHZ,'Transducer 3','Transducer 4'
CORR:TSET:RANG3 10MHZ,30MHZ,'Transducer 3'
//Turn on the transducer set
CORR:TSET ON
```

Commands to configure transducers described elsewhere.

- `MMEMoRY:SElect[:ITEM]:TRANsdUcer:ALL` on page 578

<code>MMEMoRY:LOAD&lt;n&gt;:TFACtor</code> .....	619
<code>MMEMoRY:STORe&lt;n&gt;:TFACtor</code> .....	619
<code>[SENSe:]CORRection:SWITCh:ADDReSS</code> .....	620
<code>[SENSe:]CORRection:SWITCh:COMMeNt</code> .....	620

[SENSe:]CORRection:SWITCh:DEFault[:COMMand].....	620
[SENSe:]CORRection:SWITCh:DEFault:EXECute.....	621
[SENSe:]CORRection:SWITCh:DELete.....	621
[SENSe:]CORRection:SWITCh:INPut.....	621
[SENSe:]CORRection:SWITCh:LOAD.....	621
[SENSe:]CORRection:SWITCh:NAME.....	622
[SENSe:]CORRection:SWITCh:OPC.....	622
[SENSe:]CORRection:SWITCh:RANGe<range>[:COMMand].....	622
[SENSe:]CORRection:SWITCh:RANGe<range>:EXECute.....	623
[SENSe:]CORRection:SWITCh:SCPI.....	623
[SENSe:]CORRection:SWITCh:SELect.....	623
[SENSe:]CORRection:SWITCh:STORe.....	623
[SENSe:]CORRection:SWITCh:WAIT.....	624
[SENSe:]CORRection:TRANsdUcer:INPut<rf>:ACTive?.....	624
[SENSe:]CORRection:TRANsdUcer:ACTive?.....	624
[SENSe:]CORRection:TRANsdUcer:ADJust:RLEVel[:STATe].....	624
[SENSe:]CORRection:TRANsdUcer:CATalog?.....	624
[SENSe:]CORRection:TRANsdUcer:COMMeNt.....	625
[SENSe:]CORRection:TRANsdUcer:DATA.....	625
[SENSe:]CORRection:TRANsdUcer:DELete.....	626
[SENSe:]CORRection:TRANsdUcer:SCALing.....	626
[SENSe:]CORRection:TRANsdUcer:SELect.....	626
[SENSe:]CORRection:TRANsdUcer:INPut<rf>[:STATe].....	626
[SENSe:]CORRection:TRANsdUcer[:STATe].....	626
[SENSe:]CORRection:TRANsdUcer:UNIT.....	626
[SENSe:]CORRection:TSET:BREak.....	627
[SENSe:]CORRection:TSET:CATalog?.....	627
[SENSe:]CORRection:TSET:COMMeNt.....	628
[SENSe:]CORRection:TSET:DELete.....	628
[SENSe:]CORRection:TSET:RANGe<range>.....	628
[SENSe:]CORRection:TSET:SELect.....	629
[SENSe:]CORRection:TSET:UNIT.....	629
[SENSe:]CORRection:TSET:INPut<rf>[:STATe].....	629
[SENSe:]CORRection:TSET[:STATe].....	629

---

#### **MMEMory:LOAD<n>:TFACtor <FileName>**

Loads the transducer factor from the selected file in .CSV format.

##### **Suffix:**

<n>                      irrelevant

##### **Parameters:**

<FileName>              String containing the path and name of the CSV import file.

##### **Example:**

MMEM:LOAD:TFAC 'C:\TEST.CSV'

---

#### **MMEMory:STORe<n>:TFACtor <FileName>,<TransdName>**

This command exports transducer factor data to an ASCII (CSV) file.

For details on the file format see [Chapter 11.3.3, "Reference: Transducer Factor File Format"](#), on page 315.

**Suffix:**

<n> irrelevant

**Parameters:**

<FileName> String containing the path and name of the target file.

<TransdName> Name of the transducer factor to be exported.

**Example:**

```
MMEM:STOR:TFAC 'C:\TEST', 'Transducer1'
Stores the transducer factor named "Transducer1" in the file
TEST.CSV.
```

**[SENSe:]CORRection:SWITCh:ADDRess <NetworkAddress>**

This command defines the network address of the switch matrix.

**Parameters:**

<NetworkAddress> String containing the network address of the switch matrix.  
Make sure to add the type of network protocol to the string.

**Example:**

```
CORR:SWIT:ADDR 'TCPIP::192.0.2.0::INSTR'
CORR:SWIT:ADDR 'TCPIP::192.0.2.0::HISLIP'
CORR:SWIT:ADDR 'GPIB::20::INSTR'
Connects to a device with the corresponding network addresses.
```

**Manual operation:** See ["Connecting the R&S ESW to the RF switch"](#) on page 314

**[SENSe:]CORRection:SWITCh:COMMeNT <Comment>**

This command defines a comment for a dataset that controls a switch matrix.

**Parameters:**

<Comment> String containing the comment.

**Example:**

```
CORR:SWIT:COMM 'This is a comment.'
Defines a comment.
```

**Manual operation:** See ["Defining dataset name and file name"](#) on page 313

**[SENSe:]CORRection:SWITCh:DEFault[:COMMaND] <Command>**

This command defines a remote command that is sent to the switch matrix before all other commands.

This is useful, for example, to configure the switch matrix into a predefined state.

**Parameters:**

<Command> String containing the command.

**Example:**

```
CORR:SWIT:DEF 'SYST:PRES'
Presets the switch matrix to its default state before the actual
measurement starts.
```

**Manual operation:** See ["Controlling the RF switch"](#) on page 314

---

#### [SENSe:]CORRection:SWITCh:DEFault:EXECute

This command deliberately sends the command defined by [SENSe:]CORRection:SWITCh:DEFault[:COMManD] to the switch matrix.

**Example:**           CORR:SWIT:DEF 'SYST:PRES'  
                   CORR:SWIT:DEF:EXEC  
                   Sends SYSTem:PRESet to the switch matrix and restores its default configuration.

**Usage:**            Event

**Manual operation:** See ["Controlling the RF switch"](#) on page 314

---

#### [SENSe:]CORRection:SWITCh:DELeTe <FileName>

This command deletes a dataset that controls a switch matrix.

**Parameters:**  
 <FileName>           String containing the file name and path.

**Example:**           CORR:SWIT:DEL 'aSwitchProgram'  
                   Deletes the dataset called "aSwitchProgram.xml".

**Usage:**            Event

---

#### [SENSe:]CORRection:SWITCh:INPut <Input>

This command selects the RF input of the R&S ESW used for the measurement with the switch matrix.

**Parameters:**  
 <Input>              **INP1**  
                           Selects RF input 1.  
                           **INP2**  
                           Selects RF input 2.  
                           **OFF**  
                           No input is used.

**Example:**           CORR:SWIT:INP INP1  
                   Measurement takes place on RF input 1.

**Manual operation:** See ["Selecting the RF input"](#) on page 314

---

#### [SENSe:]CORRection:SWITCh:LOAD <FileName>

This command restores a previously saved dataset that controls a switch matrix.

**Parameters:**  
 <FileName>           String containing the file name and path.

**Example:** `CORR:SWIT:LOAD 'X:\Dataset.xml'`  
Restore a dataset on drive X:\.

**Usage:** Event

#### **[SENSe:]CORRection:SWITCh:NAME <Name>**

This command defines a name for a dataset that controls a switch matrix.

**Parameters:**

<Name> String containing the name of the dataset.  
The dataset name is not necessarily the file name (if you save the dataset).

**Example:** `CORR:SWIT:NAME 'SWITCH'`  
Defines a dataset name.

**Manual operation:** See ["Defining dataset name and file name"](#) on page 313

#### **[SENSe:]CORRection:SWITCh:OPC <State>**

This command turns synchronization (with \*OPC) for commands transmitted in each transducer range on and off.

**Parameters:**

<State> ON | OFF  
\*RST: ON

**Example:** `CORR:SWIT:OPC ON`  
Synchronizes the commands in each transducer range.

**Manual operation:** See ["Synchronizing the command sequence"](#) on page 315

#### **[SENSe:]CORRection:SWITCh:RANGe<range>[:COMManD] <Commands>**

This command defines commands to be sent to the switch matrix in a certain transducer range.

**Suffix:**

<range> 1...10  
Selects the transducer range.

**Parameters:**

<Commands> String of remote commands.  
If you send more than one command, separate them with a semicolon.  
For a comprehensive description of commands supported by the switch matrix, refer to its documentation.

**Example:** `CORR:SWIT:RANG4 'ROUT:CLOS (@F01A11(0101))'`

**[SENSe:]CORRection:SWITCh:RANGe<range>:EXECute**

This command deliberately sends the commands defined for a certain transducer range to the switch matrix.

**Suffix:**

<range>                    1...10  
Selects the transducer range.

**Example:**

CORR:SWIT:RANG4:EXEC  
Sends the commands defined for transducer range 4.

**Usage:**

Event

**[SENSe:]CORRection:SWITCh:SCPI <State>**

This command turns the use of remote commands that comply to the SCPI standard on and off.

Required for switch matrixes that support a command set that does not comply to the SCPI standard.

**Parameters:**

<State>                    ON | OFF  
\*RST:                    ON

**Example:**

CORR:SWIT:SCPI ON  
Command syntax has to comply to the SCPI standard.

**Manual operation:** See ["Controlling the RF switch"](#) on page 314

**[SENSe:]CORRection:SWITCh:SELEct <FileName>**

This command selects a dataset that controls a switch matrix.

Note that you have to select a dataset before you can edit it.

**Parameters:**

<FileName>                String containing the file name and path.

**Example:**

CORR:SWIT:SEL 'dataset'  
Selects a dataset called "dataset".

**Manual operation:** See ["Defining dataset name and file name"](#) on page 313

**[SENSe:]CORRection:SWITCh:STORe <FileName>**

This command defines the file name of a dataset that controls a switch matrix.

**Parameters:**

<FileName>                String containing the file name and path.  
The file type is xml.

**Example:**

CORR:SWIT:STOR 'NameOfTheFile'  
Saves the dataset in the file "NameOfTheFile.xml".

**Manual operation:** See ["Defining dataset name and file name"](#) on page 313

---

**[SENSe:]CORRection:SWITCh:WAIT <Delay>**

This command defines a delay time.

The delay time is the time the R&S ESW waits until it sends the first command used in the subsequent transducer range.

**Parameters:**

<Delay>                    <numeric value>  
                                  \*RST:        100 ms  
                                  Default unit: s

**Example:**

CORR:SWIT:WAIT?  
 would return, e.g.:  
 0.01

**Manual operation:** See ["Defining a delay time"](#) on page 315

---

**[SENSe:]CORRection:TRANsducer:INPut<rf>:ACTive?**  
**[SENSe:]CORRection:TRANsducer:ACTive?**

This command queries the currently active transducer factor.

**Parameters:**

<TransducerFactor>    String containing the name of the transducer factor.  
                                  If no transducer factor is active, the string is empty.

**Example:**

CORR:TRAN:ACT?  
 Queries the active transducer factor.

**Usage:**

Query only

---

**[SENSe:]CORRection:TRANsducer:ADJust:RLEVel[:STATe] <State>**

This command turns an automatic adjustment of the reference level to the transducer on and off.

Before you can use the command, you have to select and turn on a transducer.

**Parameters:**

<State>                    ON | OFF | 1 | 0  
                                  \*RST:        0

---

**[SENSe:]CORRection:TRANsducer:CATalog?**

This command queries all transducer factors stored on the R&S ESW.

**Parameters:**

<FileInformation> String containing the file information.  
'<NameFileN>,<SizeFileN>'  
**<NameFileN>**  
Name of the file.  
**<SizeFileN>**  
Size of the file in bytes.

**Return values:**

<UsedDiskSpace> Size of all available files containing transducer factors in byte.  
<FreeDiskSpace> Remaining disk space in bytes.

**Example:**

CORR:TRAN:CAT?  
would return, e.g.  
1579,34482896896,'FACTOR1,823','FACTOR2,756'

**Usage:**

Query only

**[SENSe:]CORRection:TRANsducer:COMMeNT <Comment>**

This command defines the comment for the selected transducer factor.

Before you can use the command, you have to select and turn on a transducer.

**Parameters:**

<Comment> \*RST: (empty comment)

**[SENSe:]CORRection:TRANsducer:DATA**

<Frequency>,<Level>[,<Frequency>,<Level>]

This command configures transducer factors for specific trace points. A set of transducer factors defines an interpolated transducer line and can be stored on the instrument.

[More information](#)**Parameters:**

<Frequency> The unit for <Frequency> is Hz, which may or may not be omitted. Frequencies have to be sorted in ascending order.  
<Level> The unit for <Level> depends on [\[SENSe:\]CORRection:TRANsducer:UNIT](#).

**Example:**

```
SENSe1:CORRection:TRANsducer:UNIT 'DB'  
// Frequency Span 0 Hz to 4 Ghz  
SENSe1:CORRection:TRANsducer:DATA 0,8,2e6,5,4GHz,3
```

Creates the transducer points:



Frequency	Level
0 Hz	8 dB
2 GHz	5 dB
4 GHz	3 dB

---

**[SENSe:]CORRection:TRANsducer:DELeTe**

This command deletes the currently selected transducer factor.

Before you can use the command, you have to select a transducer.

**Example:**                   CORR:TRAN:DEL

**Usage:**                    Event

---

**[SENSe:]CORRection:TRANsducer:SCALing <ScalingType>**

This command selects the frequency scaling of the transducer factor.

**Parameters:**

<ScalingType>           LINear | LOGarithmic  
 \*RST:                    LINear

---

**[SENSe:]CORRection:TRANsducer:SELEct <Name>**

This command selects a transducer factor.

**Parameters:**

<Name>                   String containing the name of the transducer factor.  
 If the name does not exist yet, the R&S ESW creates a transducer factor by that name.

**Example:**                   CORR:TRAN:SEL 'FACTOR1'

---

**[SENSe:]CORRection:TRANsducer:INPUt<rf>[:STATe] <State>**

**[SENSe:]CORRection:TRANsducer[:STATe] <State>**

This command turns the selected transducer factor on or off.

Before you can use the command, you have to select a transducer.

**Parameters:**

<State>                   ON | OFF | 1 | 0  
 \*RST:                    0

---

**[SENSe:]CORRection:TRANsducer:UNIT <Unit>**

This command selects the unit of the transducer factor.

Before you can use the command, you have to select and turn on a transducer.

**Parameters:**

<Unit> string as defined in table below  
 \*RST: DB

**Example:**

CORR:TRAN:UNIT 'DBUV'

String	Unit
'DB'	dB
'DBM'	dBm
'DBMV'	dBmV
'DBUV'	dB $\mu$ V
'DBUV/M'	dB $\mu$ V/m
'DBUA'	dB $\mu$ A
'DBUA/M'	dB $\mu$ A/m
'DBPW'	dBpW
'DBPT'	dBpT

**[SENSe:]CORRection:TSET:BRaek <State>**

This command turns a transducer break on and off.

Before you can use the command, you have to select a transducer set with [\[SENSe:\]CORRection:TSET:SElect](#).

**Parameters:**

<State> ON | OFF  
 \*RST: OFF

**Example:**

See [Chapter 13.9.4, "Transducers"](#), on page 618 .

**[SENSe:]CORRection:TSET:CATalog?**

This command queries all transducer sets stored on the R&S ESW.

**Return values:**

<UsedDiskSpace> Size of all available files containing transducer factors in byte.  
 <FreeDiskSpace> Remaining disk space in bytes.  
 <FileInfo> String containing the file information.  
 '<NameFileN>,<SizeFileN>'  
**<NameFileN>**  
 Name of the file.  
**<SizeFileN>**  
 Size of the file in bytes.

**Example:**           CORR:TSET:CAT?  
                   would return, e.g.  
                   3298,34482896896,'SET1,1520','SET2,1756'

**Usage:**            Query only

#### **[SENSe:]CORRection:TSET:COMMeNt <Comment>**

This command defines a comment for a transducer set.

Before you can use the command, you have to select a transducer set with [\[SENSe:\]CORRection:TSET:SELeCt](#).

**Parameters:**  
 <Comment>           String containing the comment.

**Example:**           See [Chapter 13.9.4, "Transducers"](#), on page 618 .

#### **[SENSe:]CORRection:TSET:DELeT**

This command deletes a transducer set.

Before you can use the command, you have to select a transducer set with [\[SENSe:\]CORRection:TSET:SELeCt](#).

**Example:**           CORR:TSET:SEL 'Transducer Set'  
                   CORR:TSET:DEL  
                   Deletes the transducer set.

**Usage:**            Event

#### **[SENSe:]CORRection:TSET:RANGe<range> <Frequency>, <Frequency>, <FileName>**

This command selects a set of transducer factors used for a particular frequency range.

Ranges 1 to 10 must be sent in ascending order.

Before you can use the command, you have to select a transducer set with [\[SENSe:\]CORRection:TSET:SELeCt](#).

**Suffix:**  
 <range>            1...10  
                   Selects the range.

**Parameters:**  
 <Frequency>        Defines the start frequency of the frequency range.  
 <Frequency>        Defines the stop frequency of the frequency range.  
 <FileName>         String containing the name of the transducer factor.  
                   Note that you can assign up to eight transducer factors to a particular frequency range. In that case, add additional strings containing the file name after the first one separated by comma.

**Example:** See [Chapter 13.9.4, "Transducers"](#), on page 618 .

---

**[SENSe:]CORRection:TSET:SElect** <FileName>

This command creates or selects a transducer set.

**Parameters:**

<FileName> String containing the name of the transducer set.  
If the name does not exist yet, the R&S ESW creates a transducer set by that name.

**Example:** See [Chapter 13.9.4, "Transducers"](#), on page 618 .

---

**[SENSe:]CORRection:TSET:UNIT** <Unit>

This command selects the unit of a transducer set.

Note that the unit of all transducer factors in a transducer set must be the same or in relative terms (dB).

Before you can use the command, you have to select a transducer set with [\[SENSe:\]CORRection:TSET:SElect](#).

**Parameters:**

<Unit> String containing one of the following units:  
DB | DBM | DBUV | DBUV\_M | DBUA | DBUA\_M | DBPW | DBPT  
  
\*RST: DB

**Example:** See [Chapter 13.9.4, "Transducers"](#), on page 618 .

---

**[SENSe:]CORRection:TSET:INPut<rf>[:STATe]** <State>

**[SENSe:]CORRection:TSET[:STATe]** <State>

This command turns a transducer set on and off.

Before you can use the command, you have to select a transducer set with [\[SENSe:\]CORRection:TSET:SElect](#).

**Parameters:**

<State> ON | OFF  
  
\*RST: OFF

**Example:** See [Chapter 13.9.4, "Transducers"](#), on page 618 .

## 13.9.5 Display Layout and Elements

- [Screen Element Selection](#).....630
- [Colors and Schemes](#).....633
- [CMAP Suffix Assignment](#).....635

### 13.9.5.1 Screen Element Selection

Commands to configure screen elements described elsewhere.

- `DISPlay[:WINDow<n>]:MTABLE` on page 530
- `DISPlay:FORMat` on page 504

<code>DISPlay:ANNotation:CBAR</code> .....	630
<code>DISPlay:ANNotation:FREQuency</code> .....	630
<code>DISPlay:ITERm[:STATe]</code> .....	630
<code>DISPlay:SBAR[:STATe]</code> .....	631
<code>DISPlay:SKEYs[:STATe]</code> .....	631
<code>DISPlay:TBAR[:STATe]</code> .....	631
<code>DISPlay:TOUChscreen[:STATe]</code> .....	631
<code>DISPlay[:WINDow]:TIME</code> .....	632
<code>DISPlay[:WINDow]:TIME:FORMat</code> .....	632
<code>INPut:TERMinator</code> .....	632
<code>SYSTem:DISPlay:FPANel[:STATe]</code> .....	633

---

#### **DISPlay:ANNotation:CBAR** <State>

This command hides or displays the channel bar information.

##### Parameters:

<State>            ON | OFF | 0 | 1  
 \*RST:            1

**Example:**            `DISP:ANN:CBAR OFF`

**Manual operation:** See " [Channel Bar](#) " on page 297

---

#### **DISPlay:ANNotation:FREQuency** <State>

This command turns the label of the x-axis on and off.

##### Parameters:

<State>            ON | OFF | 0 | 1  
 \*RST:            1

**Example:**            `DISP:ANN:FREQ OFF`

**Manual operation:** See " [Diagram Footer \(Annotation\)](#) " on page 297

---

#### **DISPlay:ITERm[:STATe]** <State>

This command turns the display of the "Disconnect RF" icon on the toolbar on and off.

**Note:** This setting is maintained even after using the [PRESET] function.

##### Parameters:

<State>            ON | OFF  
 \*RST:            ON

**Example:**                   DISP:ITER ON  
                              Displays the icon in the toolbar.

**Manual operation:**   See " [Disconnect RF](#) " on page 299

---

#### **DISPlay:SBAR[:STATe]** <State>

This command turns the status bar on and off.

**Parameters:**

<State>                   ON | OFF | 0 | 1  
                              \*RST:        1

**Example:**                   DISP:SBAR:OFF

**Manual operation:**   See " [Status Bar](#) " on page 296

---

#### **DISPlay:SKEYs[:STATe]** <State>

This command turns the softkey bar on and off.

**Parameters:**

<State>                   ON | OFF | 0 | 1  
                              \*RST:        1

**Example:**                   DISP:SKEY:OFF

**Manual operation:**   See " [Softkey Bar](#) " on page 296

---

#### **DISPlay:TBAR[:STATe]** <State>

This command turns the toolbar on or off.

**Parameters:**

<State>                   ON | OFF | 1 | 0  
                              \*RST:        0

**Example:**                   DISP:TBAR ON

**Manual operation:**   See " [Toolbar](#) " on page 296

---

#### **DISPlay:TOUCHscreen[:STATe]** <State>

This command controls the touch screen functionality.

**Parameters:**

&lt;State&gt;

**ON | 1**

Touch screen is active for entire screen

**OFF | 0**

Touch screen is inactivate for entire screen

**FRAMe**

Touch screen is inactivate for the diagram area of the screen, but active for softkeys, toolbars and menus.

**\*RST:** 1**Example:**

DISP:TOUC:STAT ON

**Manual operation:**See " [Deactivating and Activating the Touchscreen](#) " on page 295**DISPlay[:WINDow]:TIME <State>**

This command adds or removes the date and time from the display.

**Parameters:**

&lt;State&gt;

**ON | OFF | 1 | 0****\*RST:** 0**Example:**

DISP:TIME ON

**Manual operation:**See " [Date and Time](#) " on page 297**DISPlay[:WINDow]:TIME:FORMat <Format>**

This command selects the time and date format.

**Parameters:**

&lt;Format&gt;

**DE**

dd.mm.yyyy hh:mm:ss

24 hour format.

**US**

mm/dd/yyyy hh:mm:ss

12 hour format.

**\*RST:** DE**Example:**

DISP:TIME ON

Switches the screen display of date and time on.

DISP:TIME:FORM US

Switches the date and time format to US.

**Manual operation:**See " [Date and Time Format](#) " on page 295**INPut:TERMinator <State>**

This command turns the RF input on and off.

Note that the command works regardless of the state of `DISPlay:ITERm[:STATE]`. Only for usage via the user interface is it necessary to turn on the display of the toolbar icon.

**Note:** This setting is maintained even after using the [PRESET] function.

**Parameters:**

<State> ON | OFF  
**ON**  
 Turns on the RF input.  
**OFF**  
 Turns off the RF input.  
 \*RST: ON

**Example:**

INP:TERM ON  
 Cuts off the RF input.

**Manual operation:** See " [Disconnect RF](#) " on page 299

**SYSTem:DISPlay:FPANel[:STATE] <State>**

This command includes or excludes the front panel keys when working with the remote desktop.

**Parameters:**

<State> ON | OFF | 0 | 1  
 \*RST: 1

**Manual operation:** See " [Front Panel](#) " on page 297  
 See " [Mini Front Panel](#) " on page 298

### 13.9.5.2 Colors and Schemes

Commands to select colors and schemes described elsewhere.

- `HCOPY:CMAP<item>:DEFault<colors>` on page 583
- `HCOPY:CMAP<item>:HSL` on page 584
- `HCOPY:CMAP<item>:PDEFined` on page 585

<code>DISPlay:CMAP&lt;item&gt;:DEFault&lt;colors&gt;</code> .....	633
<code>DISPlay:CMAP&lt;item&gt;:HSL</code> .....	634
<code>DISPlay:CMAP&lt;item&gt;:PDEFined</code> .....	634
<code>DISPlay:THEMe:CATalog?</code> .....	635
<code>DISPlay:THEMe:SElect</code> .....	635

**DISPlay:CMAP<item>:DEFault<colors>**

This command resets the color scheme for the display.



<b>Suffix:</b>	
<item>	Selects the item for which the color scheme is to be defined. For more information see <a href="#">Chapter 13.9.5.3, "CMAP Suffix Assignment"</a> , on page 635.
<colors>	1...4 1 Current colors with a white background and a black grid. 2 Optimized colors. 3 Customized colors. 4 Current screen colors (setting for hardcopies).
<b>Example:</b>	DISP:CMAP:DEF2 Selects default setting 2 for setting the colors.
<b>Usage:</b>	Event
<b>Manual operation:</b>	See " <a href="#">Screen Colors</a> " on page 300

#### DISPlay:CMAP<item>:HSL <hue>, <sat>, <lum>

This command selects the color for various screen elements in the display.

<b>Suffix:</b>	
<item>	Selects the item for which the color scheme is to be defined. For more information see <a href="#">Chapter 13.9.5.3, "CMAP Suffix Assignment"</a> , on page 635.
<b>Parameters:</b>	
<hue>	tint Range: 0 to 1
<sat>	saturation Range: 0 to 1
<lum>	brightness Range: 0 to 1
<b>Example:</b>	DISP:CMAP2:HSL 0.3,0.8,1.0 Changes the grid color.

#### DISPlay:CMAP<item>:PDEFined <Color>

This command selects a predefined color for various screen elements.

<b>Suffix:</b>	
<item>	Selects the item for which the color scheme is to be defined. For more information see <a href="#">Chapter 13.9.5.3, "CMAP Suffix Assignment"</a> , on page 635.

**Parameters:**

<Color> BLACK | BLUE | BROWn | GREen | CYAN | RED | MAGenta |  
 YELLow | WHITe | DGRAY | LGRAY | LBLUe | LGREen | LCYan |  
 LRED | LMAGenta

**Example:**

DISP:CMAP2:PDEF GRE

**Manual operation:** See "Restoring the User Settings to Default Colors" on page 302

**DISPlay:THEMe:CATalog?**

This command queries all available display themes.

**Return values:**

<Themes> String containing all available display themes.

**Example:**

DISP:THEMe:CAT?

**Usage:**

Query only

**DISPlay:THEMe:SElect <Theme>**

This command selects the display theme.

**Parameters:**

<Theme> String containing the name of the theme.  
 \*RST: SPL

**Example:**

DISP:THEM:SEL "OceanBlue"

**Manual operation:** See "Theme" on page 300

**13.9.5.3 CMAP Suffix Assignment**

Several commands to change the color settings of individual items of the display or printout are available. Which item is to be configured is defined using a <CMAP> suffix. The following assignment applies:

Suffix	Description
CMAP1	Background
CMAP2	Grid
CMAP3 *)	Common Text
CMAP4 *)	Check Status OK
CMAP5 *)	Check Status Error
CMAP6 *)	Text Special 1
CMAP7 *)	Text Special 2
CMAP8	Trace 1
CMAP9	Trace 2

Suffix	Description
CMAP10	Trace 3
CMAP11	Marker Info Text
CMAP12	Limit Lines
CMAP13	Limit and Margin Check – "Pass"
CMAP14	Limit and Margin Check – "Fail"
CMAP15 *)	Softkey Text
CMAP16 *)	Softkey Background
CMAP17 *)	Selected Field Text
CMAP18 *)	Selected Field Background
CMAP19 *)	Softkey 3D Bright Part
CMAP20 *)	Softkey 3D Dark Part
CMAP21 *)	Softkey State "On"
CMAP22 *)	Softkey State "Dialog open"
CMAP23 *)	Softkey Text Disabled
CMAP24	Logo
CMAP25	Trace 4
CMAP26	Grid – Minorlines
CMAP27	Marker
CMAP28	Display Lines
CMAP29 *)	Sweepcount – Text
CMAP30	Limit and Margin Check – Text
CMAP31	Limit and Margin Check – \\"Margin\\""
CMAP32 *)	Table Overall – Title Text
CMAP33 *)	Table Overall – Title Background
CMAP34 *)	Table Overall – Text
CMAP35 *)	Table Overall – Background
CMAP36 *)	Table Value – Title Text
CMAP37 *)	Table Value – Title Background
CMAP38 *)	Table Value – Text
CMAP39 *)	Table Value – Background
CMAP40	Trace 5

Suffix	Description
CMAP41	Trace 6
*) these settings can only be defined via the theme ( <code>DISPlay:THEMe:SElect</code> ) and are thus ignored in the SCPI command	

## 13.9.6 Measurement Channel Synchronization

- [General Coupling Manager](#)..... 637
- [Custom Coupling Manager](#)..... 642

### 13.9.6.1 General Coupling Manager

Commands to configure parameter coupling described elsewhere.

- `OUTPut<i>:LINK` on page 486

<code>INSTrument:COUPle:ACDC</code> .....	637
<code>INSTrument:COUPle:ATTen</code> .....	638
<code>INSTrument:COUPle:BWIDth</code> .....	638
<code>INSTrument:COUPle:BANDwidth</code> .....	638
<code>INSTrument:COUPle:CENTer</code> .....	638
<code>INSTrument:COUPle:DEMod</code> .....	639
<code>INSTrument:COUPle:GAIN</code> .....	639
<code>INSTrument:COUPle:LLINes</code> .....	639
<code>INSTrument:COUPle:LIMit</code> .....	639
<code>INSTrument:COUPle:MARKer</code> .....	640
<code>INSTrument:COUPle:PRESel</code> .....	640
<code>INSTrument:COUPle:PROT</code> .....	640
<code>INSTrument:COUPle:SPAN</code> .....	641
<code>INSTrument:COUPle:VBW</code> .....	641

---

#### `INSTrument:COUPle:ACDC <State>`

This command turns synchronization of the AC / DC Coupling state between measurement channels on and off.

##### Parameters:

`<State>`                    **ALL | 1**  
Turns on synchronization.

**NONE | 0**  
Turns off synchronization.

\*RST:                    ALL

##### Example:

```
INST:COUP:ACDC ALL
Synchronizes the "AC/DC Coupling" parameter.
```

**Manual operation:** See "[Synchronizing parameters across all measurement channels](#)" on page 336

**INSTrument:COUPle:ATTen** <State>

This command turns synchronization of the attenuation and unit between measurement channels on and off.

**Parameters:**

<State>                   **ALL | 1**  
Turns on synchronization.

**NONE | 0**  
Turns off synchronization.

\*RST:            ALL

**Example:**                INST:COUP:ATT ALL  
Synchronizes the attenuation.

**Manual operation:** See ["Synchronizing parameters across all measurement channels"](#) on page 336

**INSTrument:COUPle:BWIDth** <State>**INSTrument:COUPle:BANDwidth** <State>

This command turns synchronization of the resolution bandwidth (and filter type) between measurement channels on and off.

**Parameters:**

<State>                   **ALL | 1**  
Turns on synchronization.

**NONE | 0**  
Turns on synchronization.

\*RST:            NONE

**Example:**                INST:COUP:BWID ALL  
Synchronizes the resolution bandwidth.

**Manual operation:** See ["Synchronizing parameters across all measurement channels"](#) on page 336

**INSTrument:COUPle:CENTer** <State>

This command turns synchronization of the frequency between measurement channels on and off.

**Parameters:**

<State>                   **ALL | 1**  
Turns on synchronization.

**NONE | 0**  
Turns off synchronization.

\*RST:            ALL

**Example:**                INST:COUP:CENT ALL  
Synchronizes the receiver (or center) frequency.

**Manual operation:** See ["Synchronizing parameters across all measurement channels"](#) on page 336

---

#### **INSTrument:COUPle:DEMod** <State>

This command turns synchronization of the output configuration between measurement channels on and off.

**Parameters:**

<State>           **ALL | 1**  
Turns on synchronization.

**NONE | 0**  
Turns off synchronization.

\*RST:           NONE

**Example:**           INST:COUP:DEM ALL  
Synchronizes the output configuration.

---

#### **INSTrument:COUPle:GAIN** <State>

This command turns synchronization of the preamplifier configuration between measurement channels on and off.

**Parameters:**

<State>           **ALL | 1**  
Turns on synchronization.

**NONE | 0**  
Turns off synchronization.

\*RST:           NONE

**Example:**           INST:COUP:GAIN ALL  
Synchronizes the preamplifier configuration.

**Manual operation:** See ["Synchronizing parameters across all measurement channels"](#) on page 336

---

#### **INSTrument:COUPle:LLINes** <State>

#### **INSTrument:COUPle:LIMit** <State>

This command turns synchronization of limit lines between measurement channels on and off.

**Parameters:**

<State>           **ALL | 1**  
Turns on synchronization.  
Limit lines have to be compatible to the x-axis and y-axis configuration for successful synchronization.

**NONE | 0**  
Turns off synchronization.

\*RST:           ALL

**Example:** `INST:COUP:LIM ALL`  
Synchronizes the limit lines.

**Manual operation:** See ["Synchronizing parameters across all measurement channels"](#) on page 336

#### **INSTrument:COUPle:MARKer <State>**

This command turns synchronization of the receiver frequency in the Receiver application and the Marker 1 frequency in the Spectrum application on and off.

##### **Parameters:**

<State>           **ALL | 1**  
Turns on synchronization.

**NONE | 0**  
Turns off synchronization.

\*RST:           NONE

**Example:** `INST:COUP:MARK ALL`  
Synchronizes the receiver frequency and the marker frequency.

**Manual operation:** See ["Synchronizing parameters across all measurement channels"](#) on page 336

#### **INSTrument:COUPle:PRESel <State>**

This command turns synchronization of the preselector configuration between measurement channels on and off.

##### **Parameters:**

<State>           **ALL | 1**  
Turns on synchronization.

**NONE | 0**  
Turns off synchronization.

\*RST:           ALL

**Example:** `INST:COUP:PRE ALL`  
Synchronizes the preselector configuration.

**Manual operation:** See ["Synchronizing parameters across all measurement channels"](#) on page 336

#### **INSTrument:COUPle:PROT <State>**

This command turns synchronization of the input protection between measurement channels on and off.

(→ [10 dB Minimum Attenuation](#))

**Parameters:**

<State>           **ALL | 1**  
Turns on synchronization.

**NONE | 0**  
Turns off synchronization.

\*RST:            NONE

**Example:**

INST:COUP:PROT ALL  
Synchronizes the "10 dB Min" parameter.

**Manual operation:** See ["Synchronizing parameters across all measurement channels"](#) on page 336

**INSTrument:COUPle:SPAN <State>**

This command turns synchronization of the start and stop frequency between measurement channels on and off.

**Parameters:**

<State>           **ALL | 1**  
Turns on synchronization.

**NONE | 0**  
Turns off synchronization.

\*RST:            NONE

**Example:**

INST:COUP:SPAN ALL  
Synchronizes the start and stop frequency.

**Manual operation:** See ["Synchronizing parameters across all measurement channels"](#) on page 336

**INSTrument:COUPle:VBW <State>**

This command turns synchronization of the video bandwidth between measurement channels on and off.

**Parameters:**

<State>           **ALL | 1**  
Turns on synchronization.

**NONE | 0**  
Turns off synchronization.

\*RST:            NONE

**Example:**

INST:COUP:VBW ALL  
Synchronizes the video bandwidth.

**Manual operation:** See ["Synchronizing parameters across all measurement channels"](#) on page 336



### 13.9.6.2 Custom Coupling Manager

INSTrument:COUPle:USER<j>.....	642
INSTrument:COUPle:USER<j>:CHANnel:LIST?.....	642
INSTrument:COUPle:USER<j>:ELEMeNt:LIST?.....	643
INSTrument:COUPle:USER<j>:INFO?.....	644
INSTrument:COUPle:USER<j>:NEW?.....	644
INSTrument:COUPle:USER<j>:NUMBers:LIST?.....	646
INSTrument:COUPle:USER<j>:RELation.....	647
INSTrument:COUPle:USER<j>:REMOve.....	647
INSTrument:COUPle:USER<j>:STATe.....	648
INSTrument:COUPle:USER<j>:WINDow:LIST?.....	648

---

#### INSTrument:COUPle:USER<j> <see below>

This command edits an existing custom synchronization mechanism.

For a list of parameters, including return values, see `INSTrument:COUPle:USER<j>:NEW?`. Note, however, that for `INSTrument:COUPling:USER<j>`, the last two parameters (<Direction> and <State>) are **not optional**.

**Note:** Make sure to state the right index number via the suffix at `USER`.

#### Suffix:

<j>                      Selects the index of a custom synchronization mechanism. You can query the index with `INSTrument:COUPle:USER<j>:NUMBers:LIST?`.

#### Example:

```
INST:COUP:USER3 'Receiver', 'All
Windows', 'Attenuation', 'Spectrum 2', 'All
Windows', 'Attenuation', BID, ON
```

Synchronizes the attenuation between the channels named 'Receiver' and 'Spectrum 2' in both directions and turns on the coupling.

**Manual operation:** See "Selecting the channels to synchronize" on page 339  
 See "Selecting the measurement windows to synchronize" on page 340  
 See "Selecting the parameter to synchronize" on page 340  
 See "Applying the coupling mechanism" on page 341

---

#### INSTrument:COUPle:USER<j>:CHANnel:LIST?

This command queries the names of the measurement channels that can be synchronized.

#### Suffix:

<j>                      irrelevant

#### Return values:

<Synchronizable Channel>                      All channels that can be synchronized (as a comma-separated list of strings).

- Example:** INST:COUP:USER:CHAN:LIST?  
would return, e.g.:  
'SPEC1', 'AD1', 'REC1', 'REC2', 'All Spectrum', 'All Channels', 'All Receiver', 'All Analog Demod'
- Usage:** Query only
- Manual operation:** See ["Selecting the channels to synchronize"](#) on page 339

**INSTrument:COUPle:USER<j>:ELEMeNt:LIST?** [<ChannelName>, <Parameter>]

This command queries parameters that can be synchronized.

**Suffix:**

<j> irrelevant

**Query parameters:**

<ChannelName> Optional SCPI parameter.  
String containing the name of a measurement channel.

<Parameter> Optional SCPI parameter.  
String containing the name of a parameter that you can synchronize.

**Return values:**

<Synchronizable  
Parameter>

**Case 1** (command without SCPI parameters):  
All parameters that can be synchronized (as a comma-separated list of strings).

**Case 2** (command with one SCPI parameter):  
Parameters that can be synchronized for the selected <ChannelName> (as a comma-separated list of strings).

**Case 3** (command with two SCPI parameters):  
Parameters that can be synchronized with the parameter selected with <Parameter> (as a comma-separated list of strings).  
(If the <Parameter> cannot be synchronized in the selected <ChannelName>, the command returns nothing.)

<b>Example:</b>	<p><b>Case 1</b>  <code>INST:COUP:USER:ELEM:LIST?</code>  would return a list of all parameters that you can synchronize:  'AC DC Coupling', 'Attenuation', 'Center Frequency', 'Display Lines', 'Frequency Marker 1', ...</p> <p><b>Case 2</b>  <code>INST:COUP:USER:ELEM:LIST? 'Receiver'</code>  would return all parameters that can be coupled in the 'Receiver' channel:  'AC DC Coupling', 'Attenuation', 'Center Frequency', 'Display Lines', ...</p> <p><b>Case 3</b>  <code>INST:COUP:USER:ELEM:LIST? 'Spectrum', 'Attenuation'</code>  would return all parameters that can be coupled to 'Attenuation' in the 'Spectrum' channel:  'Attenuation'  (Because the attenuation is the only parameter that can be coupled to the attenuation.)</p>
<b>Usage:</b>	Query only
<b>Manual operation:</b>	See <a href="#">"Selecting the parameter to synchronize"</a> on page 340

**INSTrument:COUPle:USER<j>:INFO?**

This command queries additional information about a custom coupling mechanism.

**Suffix:**

<j> Selects the index of a custom synchronization mechanism. You can query the index with `INSTrument:COUPle:USER<j>:NUMBers:LIST?`.

**Parameters:**

<Information> String containing the message as displayed in the coupling manager. If the coupling message contains no message, an empty string is returned.

**Example:** `INST:COUP:USER2:INFO?`  
Queries possible information about the user coupling with index 2, and would return, e.g.:  
'Only one limit line allowed'

**Usage:** Query only

**INSTrument:COUPle:USER<j>:NEW? <see below>**

This command creates a new custom synchronization mechanism.

After the new mechanism has been created, the command returns the index number of the mechanism.

**Suffix:**

<j> irrelevant

**Parameters:**

<ChannelName> String containing the name of a measurement channel or channel type.

**<Name>**

To synchronize two specific measurement channels.

**'All Receiver'**

To synchronize all receiver channels.

**'All Spectrum'**

To synchronize all spectrum channels.

**'All IQ Analyzer'**

To synchronize all I/Q analyzer channels.

**'All Analog Demod'**

To synchronize all analog demodulation channels.

**'All Channels'**

To synchronize all channels, regardless of their type.

<Window> String containing the name of a measurement window.  
(In most cases, this is 'All Windows', because synchronizing measurement windows is only possible in the Analog Demodulation application.)

**<Name>**

To synchronize a specific window.

**'All Windows'**

To synchronize all measurement windows.

<Parameter> String containing the name of a synchronizable parameter.

<ChannelName> String containing the name of a measurement channel or channel type.

The second channel name is only necessary for synchronization between two specific channels. When you synchronize all channels of the same type or all channels, the string has to be empty.

<Window> String containing the name of a measurement window.  
The second window name is only necessary for synchronization between two specific channels. When you synchronize all channels of the same type or all channels, the string has to be empty.

<Parameter> String containing the name of a synchronizable parameter.  
The second parameter name is only necessary for synchronization between two specific channels. When you synchronize all channels of the same type or all channels, the string has to be empty.

<Direction>	Optional SCPI parameter. <b>BIDir</b> Changes of a parameter get applied both ways (from channel 1 to channel 2 and vice versa). <b>LTOR</b> Changes of a parameter get applied from channel 1 to channel 2, but not the other way around. <b>RTOL</b> Changes of a parameter get applied from channel 2 to channel 1, but not the other way around.
<State>	ON   OFF Optional SCPI parameter.
<b>Return values:</b>	
<Index>	Index number of the new custom coupling. Note that the returned index numbers do not necessarily have to be the same as those shown in the user interface.
<b>Example:</b>	<pre>INST:COUP:USER:NEW? 'Receiver', 'All Windows', 'Attenuation', 'Spectrum', 'All Windows', 'Attenuation', BID, ON</pre> would return, e.g.: 3 Synchronizes the attenuation between the channels named 'Receiver' and 'Spectrum' in both directions and turns on the coupling. Also returns the index number of the custom coupling.
<b>Example:</b>	<pre>INST:COUP:USER:NEW? 'All Receiver', 'All Windows', 'Attenuation', '', '', '', BID, ON</pre> would return, e.g.: 3 Synchronizes the attenuation between all Receiver channels in both directions and turns on the coupling. Also returns the index number of the custom coupling.
<b>Usage:</b>	Query only
<b>Manual operation:</b>	See <a href="#">"Selecting the channels to synchronize"</a> on page 339 See <a href="#">"Selecting the measurement windows to synchronize"</a> on page 340 See <a href="#">"Selecting the parameter to synchronize"</a> on page 340 See <a href="#">"Applying the coupling mechanism"</a> on page 341

---

**INSTrument:COUPle:USER<j>:NUMBers:LIST?**

This command queries the index number of custom synchronization mechanisms.

The index numbers define the range for suffix <j> available for the following commands:

- `INSTrument:COUPle:USER<j>`

- `INSTrument:COUPle:USER<j>:STATe`
- `INSTrument:COUPle:USER<j>:REMOve`
- `INSTrument:COUPle:USER<j>:RELation`

**Suffix:**

<j> irrelevant

**Return values:**

<Index> Index numbers of all available custom couplings (as a comma-separated list of strings).  
Note that the returned index numbers do not necessarily have to be the same as those shown in the user interface.

**Example:**

`INST:COUP:USER:NUMB:LIST?`

would return, e.g.:

`'1','2','4'`

(Number '3' is not returned, because a coupling with that index does not exist anymore.)

**Usage:**

Query only

**INSTrument:COUPle:USER<j>:RELation <Direction>**

This command selects the direction in which synchronization works.

Note that the command is not available if you synchronize over all channels or all channels of the same application.

**Suffix:**

<j> Selects the index of a custom synchronization mechanism.  
You can query the index with `INSTrument:COUPle:USER<j>:NUMBers:LIST?`.

**Parameters:**

<Direction>

**BIDir**

Changes of a parameter get applied both ways (from channel 1 to channel 2 and vice versa).

**LTOR**

Changes of a parameter get applied from channel 1 to channel 2, but not the other way around.

**RTOL**

Changes of a parameter get applied from channel 2 to channel 1, but not the other way around.

**Example:**

`INST:COUP:USER:REL BID`

Selects bidirectional changes for the custom coupling with the index number 1.

**INSTrument:COUPle:USER<j>:REMOve [<Scope>]**

This command deletes a custom coupling mechanism.

<b>Suffix:</b>	
<j>	Selects the index of a custom synchronization mechanism. You can query the index with <code>INSTrument:COUPle:USER&lt;j&gt;:NUMBers:LIST?</code> .
<b>Parameters:</b>	
<Scope>	<b>ALL</b> Optional SCPI parameter. Deletes all custom couplings. You do not have to use the suffix <j> in that case.
<b>Example:</b>	<code>INST:COUP:USER3:REM</code> Removes the custom coupling with the index number 3.
<b>Usage:</b>	Event

**INSTrument:COUPle:USER<j>:STATe <State>**

This command turns a custom coupling mechanism on and off.

<b>Suffix:</b>	
<j>	Selects the index of a custom synchronization mechanism. You can query the index with <code>INSTrument:COUPle:USER&lt;j&gt;:NUMBers:LIST?</code> .
<b>Parameters:</b>	
<State>	ON   OFF
<b>Example:</b>	<code>INST:COUP:USER2:STAT ON</code> Turns on the coupling with the index number 2.

**INSTrument:COUPle:USER<j>:WINDow:LIST? [<ChannelName>, <Parameter>]**

This command queries the measurement windows that can be synchronized with another channel (or measurement window).

Note that synchronizing with a specific measurement window is only possible in Analog Demodulation application.

<b>Suffix:</b>	
<j>	irrelevant
<b>Query parameters:</b>	
<ChannelName>	Optional SCPI parameter. String containing the name of a measurement channel.
<Parameter>	Optional SCPI parameter. String containing the name of a parameter that you can synchronize.

**Return values:**

<Synchronizable  
Window>

**Case 1** (command without SCPI parameters):

Always returns the string 'All Windows'.

**Case 2** (command with SCPI parameters):

String containing the names of the measurement windows that you can synchronize (as a comma-separated list of strings). (Content other than 'All Windows' is only returned for marker coupling, because this is the only feature that works independent of the measurement window.)

**Example:****Case 1**

INST:COUP:USER:WIND:LIST?

would return:

'All Windows'

**Case 2**

INST:COUP:USER:WIND:LIST? 'Analog  
Demod', 'Frequency Marker 1'

would return, e.g.:

'All Windows', '1', '2', '3', '4', '5', '6'

**Usage:**

Query only

**Manual operation:** See ["Selecting the measurement windows to synchronize"](#) on page 340

### 13.9.7 Network and Remote Control Configuration

SYSTem:COMMunicate:GPIB[:SELF]:ADDRess.....	650
SYSTem:COMMunicate:GPIB[:SELF]:RTERminator.....	650
SYSTem:DISPlay:MESSAge[:TEXT].....	650
SYSTem:DISPlay:MESSAge:STATe.....	650
SYSTem:DISPlay:UPDate.....	651
SYSTem:ERRor:CLEar:REMote.....	651
SYSTem:ERRor:DISPlay.....	651
SYSTem:HPCoupling.....	652
SYSTem:IFGain:MODE.....	652
SYSTem:IDENtify:FACTory.....	652
SYSTem:IDENtify[:STRing].....	653
SYSTem:KLOCK.....	653
SYSTem:LANGuage.....	653
SYSTem:LXI:INFO?.....	653
SYSTem:LXI:LANReset.....	654
SYSTem:LXI:MDEscription.....	654
SYSTem:LXI:PASSword.....	654
SYSTem:PSA:WIDeband.....	654
SYSTem:REVisIon:FACTory.....	655
SYSTem:REVisIon[:STRing].....	655
SYSTem:RSWeep.....	656



---

**SYSTem:COMMunicate:GPIB[:SELF]:ADDRess** <Address>

This command sets the GPIB address of the R&S ESW.

**Parameters:**

<Address>	Range:	0 to 30
	*RST:	(no influence on this parameter, factory default 20)

**Example:** `SYST:COMM:GPIB:ADDR 18`**Manual operation:** See "[GPIB Address](#)" on page 389

---

**SYSTem:COMMunicate:GPIB[:SELF]:RTERminator** <Terminator>

This command selects the GPIB receive terminator.

Output of binary data from the instrument to the control computer does not require such a terminator change.

**Parameters:**

<Terminator>            LFEOI | EOI

**LFEOI**

According to the standard, the terminator in ASCII is <LF> and/or <EOI>.

**EOI**

For binary data transfers (e.g. trace data) from the control computer to the instrument, the binary code used for <LF> might be included in the binary data block, and therefore should not be interpreted as a terminator in this particular case. This can be avoided by using only the receive terminator EOI.

\*RST:            LFEOI

**Example:** `SYST:COMM:GPIB:RTER EOI`**Manual operation:** See "[GPIB Terminator](#)" on page 389

---

**SYSTem:DISPlay:MESSAge[:TEXT]** <Message>

This command defines a custom message that is displayed when you control the R&S ESW remotely.

You can turn off the display with `SYSTem:DISPlay:MESSAge:STATe`.

**Parameters:**

<Message>            String containing the message you want to display.

**Example:** `//Define message to be displayed.  
SYST:DISP:MESS 'a message'`

---

**SYSTem:DISPlay:MESSAge:STATe** <State>

This command turns the display of a custom message in [local lockout](#) state on and off.

This can be useful, for example, to indicate which device controls the R&S ESW.

You can define the message with `SYSTem:DISPlay:MESSage [:TEXT]`.

**Parameters:**

<State>                    **ON**  
 Displays a custom message.  
 Shows a message "Remote Mode controlled by <string>", including the network address of the controlling device.

**OFF**

Displays the standard message ("Remote mode").

\*RST:            OFF

**Example:**

```
//Define and display custom message
SYST:DISP:MESS 'a computer'
SYST:DISP:MESS:STAT ON
//would display:
Remote mode controlled by a computer
```

**SYSTem:DISPlay:UPDate <State>**

This command turns the display during remote operation on and off.

If on, the R&S ESW updates the diagrams, traces and display fields only.

The best performance is obtained if the display is off during remote control operation.

**Parameters:**

<State>                    ON | OFF | 1 | 0  
 \*RST:            0

**Example:**

```
SYST:DISP:UPD ON
```

**Manual operation:** See "[Remote Display Update](#)" on page 389

**SYSTem:ERRor:CLEar:REMote**

This command deletes all contents of the "Remote Errors" table.

Note: The remote error list is automatically cleared when the R&S ESW is shut down.

**Example:**

```
SYST:ERR:CLE:REM
```

**Usage:**

Event

**Manual operation:**

See "[Display Remote Errors](#)" on page 390  
 See "[Clear Error List](#)" on page 396

**SYSTem:ERRor:DISPlay <State>**

This command the error display during remote operation on and off.

If activated, the R&S ESW displays a message box at the bottom of the screen that contains the most recent type of error and the command that caused the error.

**Parameters:**

<State> ON | OFF | 1 | 0  
 \*RST: 0

**Example:** SYST:ERR:DISP ON

**Manual operation:** See ["Display Remote Errors"](#) on page 390

**SYSTem:HPCoupling** <CouplingType>

Controls the default coupling ratios in the HP emulation mode for:

- span and resolution bandwidth (Span/RBW) and
- resolution bandwidth and video bandwidth (RBW/VBW)

This command is only available if a HP language is selected using [SYSTem:LANGuage](#) on page 653.

**Parameters:**

<CouplingType> HP | FSP  
 \*RST: FSP

**Example:** SYSTem:HPC HP

**Manual operation:** See ["Coupling"](#) on page 392

**SYSTem:IFGain:MODE** <Mode>

Configures the internal IF gain settings in HP emulation mode due to the application needs. This setting is only taken into account for resolution bandwidth < 300 kHz and is only available if a HP language is selected using [SYSTem:LANGuage](#).

**Parameters:**

<Mode> NORM | PULS

**NORM**  
 Optimized for high dynamic range, overload limit is close to reference level.

**PULS**  
 Optimized for pulsed signals, overload limit up to 10 dB above reference level.

\*RST: NORM

**Example:** SYST:IFG:MODE PULS

**Manual operation:** See ["IF Gain"](#) on page 392

**SYSTem:IDENTify:FACTory**

This command resets the query to [\\*IDN?](#) to its default value.

**Usage:** Event

**Manual operation:** See ["Reset to Factory String"](#) on page 389

---

**SYSTem:IDENtify[:STRing]** <String>

This command defines the response to \*IDN?.

**Parameters:**

<String>                      String containing the description of the instrument.

**Manual operation:**    See "Identification String" on page 389

---

**SYSTem:KLOCK** <State>

This command activates the local lockout (remote control) or returns to the local mode.

**Parameters:**

<State>                      **ON**  
                                  LLO (local lockout)  
                                  **OFF**  
                                  GTL (go to local)  
\*RST:                        OFF

**Example:**                    SYST:KLOCK ON  
                                  Activates LLO (remote control)

**Manual operation:**    See "Local" on page 396

---

**SYSTem:LANGUage** <Language>

This command selects the system language.

For details see [Chapter 12.2, "GPIB Languages"](#), on page 383.

**Parameters:**

<Language>                    "SCPI" | "8560E" | "8561E" | "8562E" | "8563E" | "8564E" |  
                                  "8565E" | "8566A" | "8566B" | "8568A" | "8568A\_DC" | "8568B" |  
                                  "8568B\_DC" | "8591E" | "8594E" | "71100C" | "71200C" |  
                                  "71209A" | "PSA89600" | "PSA" | "PXA" | "FSP" | "FSU" |  
                                  "FSQ" | "FSV" | "FSEA" | "FSEB" | "FSEM" | "FSEK"  
\*RST:                        SCPI

**Example:**                    SYST:LANG 'PSA'  
                                  Emulates the PSA.

**Manual operation:**    See "Language" on page 391

**Note:** If you use "PSA89600", you must switch to an HP language first before returning to SCPI (in remote operation only). For the identical language "PSA", this intermediate step is not necessary.

---

**SYSTem:LXI:INFO?**

This command queries the LXI settings.

**Return values:**

<LXIInfo> <current version> | <LXI class> | <Computername> |  
 <MAC adress> | <IP adress> | <Auto MDIX>  
 String containing the current LXI parameters.

- <version>
- <LXIclass>
- <ComputerName>
- <MACAddress>
- <IPAddress>
- <AutoMDIX>

**Usage:** Query only

**Manual operation:** See "[Current LXI Configuration](#)" on page 394

**SYSTem:LXI:LANReset**

This command resets the LAN configuration as required by the LXI standard. The command also resets the LXI password and instrument description.

**Usage:** Event

**Manual operation:** See "[LAN Reset](#)" on page 395

**SYSTem:LXI:MDEscription <Description>**

This command defines the LXI instrument description.

**Parameters:**

<Description> String containing the instrument description.

**Manual operation:** See "[LXI Manufacturer Description](#)" on page 394

**SYSTem:LXI:PASSword <Password>**

This command defines the LXI password.

**Parameters:**

<Password> String containing the password.

**Return values:**

<Password> The query returns the current password.

**Manual operation:** See "[LXI Password](#)" on page 394

**SYSTem:PSA:WIDeband <State>**

This command defines which option is returned when the \*OPT? query is executed, depending on the state of the wideband option.

It is only available for PSA89600 emulation.

**Parameters:**

<State> ON | OFF | HIGH

**OFF**  
The option is indicated as "B7J"

**ON**  
The 40 MHz wideband is used.  
The option is indicated as "B7J, 140".

**HIGH**  
The 80 MHz wideband is used.  
The option is indicated as "B7J, 122".

\*RST: OFF

**Manual operation:** See "[Language](#)" on page 391  
See "[Wideband](#)" on page 392

**SYSTem:REVision:FACTory**

Resets the response to the REV? query to the default value, e.g. after a user string was defined using the `SYSTem:REVision[:STRing]` command. (REV? query available for HP emulation only, see `SYSTem:LANGuage` on page 653.)

**Example:** Define the system language:  
`SYST:LANG '8563E'`  
Set the response back to factory setting:  
`SYS:REV:FACT`  
Query the revision:  
`REV?`  
Response:  
920528

**Usage:** Event

**Manual operation:** See "[Resetting the Factory Revision](#)" on page 393

**SYSTem:REVision[:STRing] <Name>**

Sets the response to the REV? query to the defined string (HP emulation only, see `SYSTem:LANGuage` on page 653).

**Parameters:**

<Name>

**Example:** Define the system language:  
 SYST:LANG '8563E'  
 Query the revision:  
 REV?  
 Response:  
 920528  
 Set the response to 'NewRevision':  
 SYST:REV:STR 'NewRevision'  
 Query the response:  
 SYST:REV:STR?  
 Response:  
 NewRevision

**Manual operation:** See ["Revision String"](#) on page 393

---

#### SYSTem:RSweep <State>

Controls a repeated sweep of the E1 and MKPK HI HP model commands (for details on the commands refer to [Chapter 13.12, "Reference: GPIB Commands of Emulated HP Models"](#), on page 676). If the repeated sweep is OFF, the marker is set without sweeping before.

This command is only available if a HP language is selected using [SYSTem:LANGuage](#) on page 653

#### Parameters:

<State> ON | OFF | 1 | 0  
 \*RST: 0

**Example:** SYSTem:RSW ON

**Manual operation:** See ["Sweep Repeat"](#) on page 392

## 13.9.8 System Configuration Check

Commands to check the system configuration described elsewhere.

- [DIAGnostic:SERVice:SINFO?](#) on page 663

<a href="#">DIAGnostic:INFO:CCOunt?</a> .....	657
<a href="#">DIAGnostic:SERVice:BIOSinfo?</a> .....	657
<a href="#">DIAGnostic:SERVice:HWInfo?</a> .....	657
<a href="#">DIAGnostic:SERVice:VERSinfo?</a> .....	658
<a href="#">SYSTem:ERRor:CLEar:ALL</a> .....	658
<a href="#">SYSTem:ERRor:EXTended?</a> .....	659
<a href="#">SYSTem:ERRor:LIST?</a> .....	659
<a href="#">SYSTem:ERRor[:NEXT]?</a> .....	660
<a href="#">SYSTem:FIRMware:UPDate</a> .....	660
<a href="#">SYSTem:FORMat:IDENT</a> .....	660
<a href="#">SYSTem:PRESet:COMPatible</a> .....	661
<a href="#">SYSTem:PRESet:FILTer</a> .....	661
<a href="#">SYSTem:SECurity[:STATE]</a> .....	661

---

**DIAGnostic:INFO:CCOunt? <Relay>**

This command queries how many switching cycles the individual relays have performed since they were installed.

**Query parameters:**

<Relay>	<b>ACDC</b> Mechanical Attenuation Coupling
	<b>ATT5</b> Mechanical Attenuation 05 DB
	<b>ATT10</b> Mechanical Attenuation 10 DB
	<b>ATT20</b> Mechanical Attenuation 20 DB
	<b>ATT40</b> Mechanical Attenuation 40 DB
	<b>CAL</b> Mechanical Calibration Source
	<b>EATT</b> Electrical Attenuation Bypass
	<b>PREamp</b> Preamplifier Bypass

**Return values:**

<Cycles>                    Number of switching cycles.

**Example:**                    `DIAG:INFO:CCO? CAL`

**Usage:**                      Query only

**Manual operation:**    See "[Relays Cycle Counter](#)" on page 335

---

**DIAGnostic:SERVice:BIOSinfo?**

This command queries the BIOS version of the CPU board.

**Return values:**

<BiosInformation>        String containing the BIOS version.

**Example:**                    `DIAG:SERV:BIOS?`  
Returns the BIOS version.

**Usage:**                      Query only

---

**DIAGnostic:SERVice:HWInfo?**

This command queries hardware information.



**Return values:**

<Hardware> String containing the following information for every hardware component.  
 <component>: name of the hardware component  
 <serial#>: serial number of the component  
 <order#>: order number of the component  
 <model>: model of the component  
 <code>: code of the component  
 <revision>: revision of the component  
 <subrevision>: subrevision of the component

**Example:**

```
DIAG:SERV:HWIN?
Queries the hardware information.
"FRONTEND|100001/003|1300.3009|03|01|00|00",
"MOTHERBOARD|123456/002|1300.3080|02|00|00|00",
...
```

**Usage:**

Query only

**DIAGnostic:SERvice:VERSinfo?**

This command queries information about the hardware and software components.

**Return values:**

<Information> String containing the version of hardware and software components including the types of licenses for installed options.

**Example:**

```
DIAG:SERV:VERS?
Queries the version information.
Response:
Instrument Firmware |1.00,
BIOS |R&S ANALYZER BIOS V1.70-3-14-2 IPC11,
Image Version |1.6.0,
Device Installation Version |1.3.0,
PCIE-FPGA |8.03,
SA-FPGA |10.05,
MB-FPGA |2.1.3.0,
SYNTH-FPGA |3.12.1.0,
REF-FPGA |3.4.0.0,
MWC-FPGA |3.4.0.0,
Data Sheet Version |06.00,
Time Control Management ||active,
RF Preamplifier B24||,
Real-Time Analysis K55||permanent
```

**Usage:**

Query only

**SYSTem:ERRor:CLEar:ALL**

This command deletes all contents of the "System Messages" table.

**Example:**

```
SYST:ERR:CLE:ALL
```

**Usage:** Event

---

**SYSTem:ERRor:EXTended?** <MessageType>[, <ChannelName>]

This command queries all system messages, or all messages of a defined type, displayed in the status bar for a specific channel (application).

**Note:** This command queries the strings displayed for manual operation. For remote programs, do not define processing steps depending on these results. Instead, query the results of the `STATUS:QUESTIONABLE:EXTENDED:INFO` status register, which indicates whether messages of a certain type have occurred (see "[STATUS:QUESTIONABLE:EXTENDED:INFO Register](#)" on page 374).

**Query parameters:**

<MessageType> ALL | INFO | WARNING | ERROR | FATAL | MESSAGE

<ChannelName> String containing the name of the channel.  
The parameter is optional. If you omit it, the command works for the currently active channel.

**Return values:**

<Messages> String containing all messages of the selected type for the specified channel. Each message is separated by a comma and inserted in parentheses. If no messages are available, empty parentheses are returned.

**Example:**

`SYST:ERR:EXT? ALL`

Returns all messages for the currently active application, e.g. "Message 1", "Message 2".

**Example:**

`SYST:ERR:EXT? FAT, 'Spectrum2'`

Queries fatal errors in the 'Spectrum2' application. If none have occurred, the result is: " ".

**Usage:** Query only

---

**SYSTem:ERRor:LIST?** [<MessType>]

This command queries the error messages that occur during R&S ESW operation.

**Query parameters:**

<MessType> **SMSG**  
(default) Queries the system messages which occurred during manual operation.

**REMOte**

Queries the error messages that occurred during remote operation.

Note: The remote error list is automatically cleared when the R&S ESW is shut down.

**Return values:**

<SystemMessages> String containing all messages in the "System Messages" table.

<RemoteErrors>	<Error_no>   <Description>   <Command>   <Date>   <Time> Comma-separated list of errors from the "Remote Errors" table, where: <Error_no>: device-specific error code <Description>: brief description of the error <Command>: remote command causing the error <Date> <Time>: date and time the error occurred
<b>Example:</b>	SYST:ERR:LIST?
<b>Usage:</b>	Query only

**SYSTem:ERRor[:NEXT]?**

This command queries the most recent error queue entry and deletes it.

Positive error numbers indicate device-specific errors, negative error numbers are error messages defined by SCPI. If the error queue is empty, the error number 0, "No error", is returned.

For details on error queues see [Chapter 12.1.7, "Status Reporting System"](#), on page 365.

**Usage:** Query only

**SYSTem:FIRMware:UPDate**

This command starts a firmware update using the \*.msi files in the selected directory. The default path is D:\FW\_UPDATE. The path is changed via the [MMEMory:COMment](#) command. To store the update files the [MMEMory:DATA](#) command is used.

Only user accounts with administrator rights can perform a firmware update.

**Example:** SYST:FIRM:UPD 'D:\FW\_UPDATE'  
Starts the firmware update from directory "D:\FW\_UPDATE".

**Usage:** Event

**SYSTem:FORMat:IDENt <IDNFormat>**

This command selects the response format to the \*IDN? query.

**Parameters:**

<IDNFormat>	<b>LEGacy</b> Format is compatible to R&S FSP/FSU/FSQ/FSG family.
	<b>NEW   FSL</b> R&S ESW format Format is also compatible to the R&S FSL and R&S FSV family
*RST:	not reset!

**Example:**            `SYST:FORM:IDEN LEG`  
Adapts the return value of \*IDN? to the R&S FSP/FSU/FSQ family.

**Manual operation:** See "[\\*IDN Format](#)" on page 390

### **SYSTem:PRESet:COMPAtible** <OpMode>

This command defines the operating mode that is activated when you switch on the R&S ESW or press the [PRESET] key.

**Parameters:**

<OpMode>            **SANalyzer**  
(Default:)  
Defines Signal and Spectrum Analyzer operating mode as the presetting.

**RECeiver**  
Selects the Receiver application as the default application.

**Manual operation:** See "[Preset Mode](#)" on page 327

### **SYSTem:PRESet:FILTer** <FilterType>

This command selects the resolution filter type that is selected after a preset in the Spectrum application.

**Parameters:**

<FilterType>        **NORMAL**  
Selects 3 dB filter.

**NOISe**  
Selects 3 dB filter.  
(NORMAL and NOISe have the same effect.)

**PULSe**  
Selects 6 dB filter.

\*RST:                NORMAL

**Example:**            `SYST:PRESet:FILT PULS`  
Selects the 6 dB filters as the default filter type.

**Manual operation:** See "[Default Filter Type for Spectrum Mode](#)" on page 328

### **SYSTem:SECurity[:STATe]** <State>

Activates or queries secure user mode.

**Note:** Before you activate secure user mode, store any instrument settings that are required beyond the current session, such as predefined instrument settings, transducer files, or self-alignment data.

**Note:** Initially after installation of the R&S ESW-K33 option, secure user mode must be enabled manually once before remote control is possible. This is necessary to prompt for a change of passwords.

For details on the secure user mode see [Chapter 2.7, "Protecting Data Using the Secure User Mode"](#), on page 37.

**Parameters:**

<State>

ON | OFF | 0 | 1

**ON | 1**

The R&S ESW automatically reboots and starts in secure user mode. In secure user mode, no data is written to the instrument's internal solid-state drive. Data that the R&S ESW normally stores on the solid-state drive is redirected to SDRAM.

**OFF | 0**

The R&S ESW is set to normal instrument mode. Data is stored to the internal solid-state drive.

Note: this parameter is for query only. Secure user mode cannot be deactivated via remote operation.

\*RST: 0

**Manual operation:** See "[SecureUser Mode](#)" on page 328

### 13.9.9 Service Functions

<a href="#">DIAGnostic:SERvice:SFUNction</a> .....	662
<a href="#">DIAGnostic:SERvice:SFUNction:LASTresult?</a> .....	663
<a href="#">DIAGnostic:SERvice:SFUNction:RESults:DELeTe</a> .....	663
<a href="#">DIAGnostic:SERvice:SFUNction:RESults:SAVE</a> .....	663
<a href="#">DIAGnostic:SERvice:SIInfo?</a> .....	663
<a href="#">SYSTem:PASSword:RESet</a> .....	664
<a href="#">SYSTem:PASSword[:CENable]</a> .....	664

---

#### **DIAGnostic:SERvice:SFUNction** <ServiceFunction>

This command starts a service function.

The service functions are available after you have entered the level 1 or level 2 system password.

**Parameters:**

<ServiceFunction>

String containing the ID of the service function.

The ID of the service function is made up out of five numbers, separated by a point.

- function group number
- board number
- function number
- parameter 1 (see the Service Manual)
- parameter 2 (see the Service Manual)

**Usage:**

Event

**Manual operation:** See " [Service Function](#) " on page 333  
See " [Send](#) " on page 333

---

**DIAGnostic:SERVice:SFUNction:LASTresult?**

This command queries the results of the most recent service function you have used.

**Usage:** Query only

---

**DIAGnostic:SERVice:SFUNction:RESults:DELeTe**

This command deletes the results of the most recent service function you have used.

**Usage:** Event

**Manual operation:** See " [Clear Results](#) " on page 334

---

**DIAGnostic:SERVice:SFUNction:RESults:SAVE <FileName>**

This command saves the results of the most recent service function you have used.

**Parameters:**

<FileName> String containing the file name.

**Manual operation:** See " [Save Results](#) " on page 334

---

**DIAGnostic:SERVice:SIINFo? <FileName>**

This command creates a \*.zip file with important support information. The \*.zip file contains the system configuration information ("device footprint"), the current eeprom data and a screenshot of the screen display (if available).

This data is stored to the C:\R\_S\Instr\User directory on the instrument.

As a result of this command, the created file name (including the drive and path) is returned.

You can use the resulting file name information as a parameter for the `MMEM:COPY` command to store the file on the controller PC.

If you contact the Rohde&Schwarz support to get help for a certain problem, send this file to the support in order to identify and solve the problem faster.

**Return values:**

<FileName> C:\R\_S\Instr\User  
 \<R&S Device ID>\_<CurrentDate>\_<CurrentTime>  
 String containing the drive, path and file name of the created support file, where the file name consists of the following elements:  
**<R&S Device ID>**: The unique R&S device ID indicated in the "Versions + Options" information  
**<CurrentDate>**: The date on which the file is created (<YYYYMMDD>)  
**<CurrentTime>**: The time at which the file is created (<HHMMSS>)

**Example:**

```
DIAG:SERV:SINF?
Result:
"c:\R&S\instr\user\FSW-26_1328.4100K26-100005-xx_20130116_165858.zip"

MMEM:COPY "c:\R&S\instr\user\ESW-26_1328.4100K26-100005-xx_20130116_165858.zip",
"S:\Debug\ESW-26_1328.4100K26-100005-xx_20130116_165858.zip"
```

**Usage:** Query only

**Manual operation:** See "[Create R&S Support Information](#)" on page 330

**SYSTem:PASSword:RESet**

Clears any previously provided password and returns to the most restrictive service level.

**Manual operation:** See "[Password](#)" on page 334

**SYSTem:PASSword[:CENable] <arg0>**

Provides a password for subsequent service functions.

**Parameters:**

<arg0> string

**Example:** SYST:PASS:CEN '894129'

**Manual operation:** See "[Password](#)" on page 334

## 13.10 Using the Status Register

For more information on the contents of the status registers see:

- "[STATus:OPERation Register](#)" on page 371
- "[STATus:QUESTionable:ACPLimit Register](#)" on page 373
- "[STATus:QUESTionable:EXTended Register](#)" on page 374

- "STATus:QUESTionable:FREQuency Register" on page 375
- "STATus:QUESTionable:LIMit Register" on page 376
- "STATus:QUESTionable:LMARgin Register" on page 376
- "STATus:QUESTionable:POWer Register" on page 377
- "STATus:QUESTionable:TIMe Register" on page 378
- General Status Register Commands..... 665
- Reading Out the CONDition Part..... 665
- Reading Out the EVENt Part..... 666
- Controlling the ENABle Part..... 667
- Controlling the Negative Transition Part..... 667
- Controlling the Positive Transition Part..... 668

### 13.10.1 General Status Register Commands

STATus:PRESet.....	665
STATus:QUEue[:NEXT]?	665

---

#### STATus:PRESet

This command resets the edge detectors and ENABle parts of all registers to a defined value. All PTRansition parts are set to FFFFh, i.e. all transitions from 0 to 1 are detected. All NTRansition parts are set to 0, i.e. a transition from 1 to 0 in a CONDition bit is not detected. The ENABle part of the STATus:OPERation and STATus:QUESTionable registers are set to 0, i.e. all events in these registers are not passed on.

**Usage:**                      Event

---

#### STATus:QUEue[:NEXT]?

This command queries the most recent error queue entry and deletes it.

Positive error numbers indicate device-specific errors, negative error numbers are error messages defined by SCPI. If the error queue is empty, the error number 0, "No error", is returned.

This command is identical to the `SYSTem:ERRor[:NEXT]?` command.

**Usage:**                      Query only

### 13.10.2 Reading Out the CONDition Part

For more information on the condition part see [Chapter 12.1.7.2, "Structure of a SCPI Status Register"](#), on page 367.

---

**STATus:OPERation:CONDition?**

**STATus:QUESTionable:CONDition?**

**STATus:QUESTionable:ACPLimit:CONDition? <ChannelName>**



**STATus:QUESTionable:EXTended:CONDition?** <ChannelName>  
**STATus:QUESTionable:EXTended:INFO:CONDition?** <ChannelName>  
**STATus:QUESTionable:FREQuency:CONDition?** <ChannelName>  
**STATus:QUESTionable:LIMit<n>:CONDition?** <ChannelName>  
**STATus:QUESTionable:LMARgin<n>:CONDition?** <ChannelName>  
**STATus:QUESTionable:POWer:CONDition?** <ChannelName>  
**STATus:QUESTionable:TEMPerature:CONDition?** <ChannelName>  
**STATus:QUESTionable:TRANsducer:CONDition?** <ChannelName>  
**STATus:QUESTionable:TIME:CONDition?** <ChannelName>

These commands read out the CONDition section of the status register.

The commands do not delete the contents of the CONDition section.

**Suffix:**

<n> [Window](#)

**Query parameters:**

<ChannelName> String containing the name of the channel.  
 The parameter is optional. If you omit it, the command works for the currently active channel.

**Usage:** Query only

### 13.10.3 Reading Out the EVENT Part

For more information on the event part see [Chapter 12.1.7.2, "Structure of a SCPI Status Register"](#), on page 367.

---

**STATus:OPERation[:EVENT]?**  
**STATus:QUESTionable[:EVENT]?**  
**STATus:QUESTionable:ACPLimit[:EVENT]?** <ChannelName>  
**STATus:QUESTionable:EXTended[:EVENT]?** <ChannelName>  
**STATus:QUESTionable:EXTended:INFO[:EVENT]?** <ChannelName>  
**STATus:QUESTionable:FREQuency[:EVENT]?** <ChannelName>  
**STATus:QUESTionable:LIMit<n>[:EVENT]?** <ChannelName>  
**STATus:QUESTionable:LMARgin<n>[:EVENT]?** <ChannelName>  
**STATus:QUESTionable:POWer[:EVENT]?** <ChannelName>  
**STATus:QUESTionable:TEMPerature[:EVENT]?** <ChannelName>  
**STATus:QUESTionable:TRANsducer[:EVENT]?** <ChannelName>  
**STATus:QUESTionable:TIME[:EVENT]?** <ChannelName>

These commands read out the EVENT section of the status register.

At the same time, the commands delete the contents of the EVENT section.

**Suffix:**

<n> [Window](#)

**Query parameters:**

<ChannelName> String containing the name of the channel.  
 The parameter is optional. If you omit it, the command works for the currently active channel.

**Usage:** Query only

### 13.10.4 Controlling the ENABLE Part

For more information on the enable part see [Chapter 12.1.7.2, "Structure of a SCPI Status Register"](#), on page 367.

---

**STATus:OPERation:ENABLE** <SumBit>  
**STATus:QUESTionable:ENABLE** <SumBit>  
**STATus:QUESTionable:ACPLimit:ENABLE** <SumBit>,<ChannelName>  
**STATus:QUESTionable:EXTended:ENABLE** <SumBit>,<ChannelName>  
**STATus:QUESTionable:EXTended:INFO:ENABLE** <SumBit>,<ChannelName>  
**STATus:QUESTionable:FREQUENCY:ENABLE** <SumBit>,<ChannelName>  
**STATus:QUESTionable:LIMit<n>:ENABLE** <SumBit>,<ChannelName>  
**STATus:QUESTionable:LMARgin<n>:ENABLE** <SumBit>,<ChannelName>  
**STATus:QUESTionable:POWER:ENABLE** <SumBit>,<ChannelName>  
**STATus:QUESTionable:TEMPerature:ENABLE** <SumBit>,<ChannelName>  
**STATus:QUESTionable:TRANsducer:ENABLE?** <SumBit>,<ChannelName>  
**STATus:QUESTionable:TIME:ENABLE** <SumBit>,<ChannelName>

These commands control the ENABLE part of a register.

The ENABLE part allows true conditions in the EVENT part of the status register to be reported in the summary bit. If a bit is 1 in the enable register and its associated event bit transitions to true, a positive transition will occur in the summary bit reported to the next higher level.

**Suffix:**

<n> [Window](#)

**Parameters:**

<SumBit> Range: 0 to 65535

<ChannelName> String containing the name of the channel.  
The parameter is optional. If you omit it, the command works for the currently active channel.

### 13.10.5 Controlling the Negative Transition Part

For more information on the positive transition part see [Chapter 12.1.7.2, "Structure of a SCPI Status Register"](#), on page 367.

---

**STATus:OPERation:NTRansition** <SumBit>  
**STATus:QUESTionable:NTRansition** <SumBit>  
**STATus:QUESTionable:ACPLimit:NTRansition** <SumBit>,<ChannelName>  
**STATus:QUESTionable:EXTended:NTRansition** <SumBit>,<ChannelName>  
**STATus:QUESTionable:EXTended:INFO:NTRansition** <SumBit>,<ChannelName>  
**STATus:QUESTionable:FREQUENCY:NTRansition** <SumBit>,<ChannelName>  
**STATus:QUESTionable:LIMit<n>:NTRansition** <SumBit>,<ChannelName>  
**STATus:QUESTionable:LMARgin<n>:NTRansition** <SumBit>,<ChannelName>  
**STATus:QUESTionable:POWER:NTRansition** <SumBit>,<ChannelName>

**STATus:QUESTIONable:TEMPerature:NTRansition** <SumBit>,<ChannelName>  
**STATus:QUESTIONable:TRANsducer:NTRansition?** <SumBit>,<ChannelName>  
**STATus:QUESTIONable:TIME:NTRansition** <SumBit>,<ChannelName>

These commands control the Negative TRansition part of a register.

Setting a bit causes a 1 to 0 transition in the corresponding bit of the associated register. The transition also writes a 1 into the associated bit of the corresponding EVENT register.

**Suffix:**

<n> [Window](#)

**Parameters:**

<SumBit> Range: 0 to 65535

<ChannelName> String containing the name of the channel.  
 The parameter is optional. If you omit it, the command works for the currently active channel.

### 13.10.6 Controlling the Positive Transition Part

For more information on the negative transition part see [Chapter 12.1.7.2, "Structure of a SCPI Status Register"](#), on page 367.

---

**STATus:OPERation:PTRansition** <SumBit>  
**STATus:QUESTIONable:PTRansition** <SumBit>  
**STATus:QUESTIONable:ACPLimit:PTRansition** <SumBit>,<ChannelName>  
**STATus:QUESTIONable:EXTended:PTRansition** <SumBit>,<ChannelName>  
**STATus:QUESTIONable:EXTended:INFO:PTRansition** <SumBit>,<ChannelName>  
**STATus:QUESTIONable:FREQUency:PTRansition** <SumBit>,<ChannelName>  
**STATus:QUESTIONable:LIMit<n>:PTRansition** <SumBit>,<ChannelName>  
**STATus:QUESTIONable:LMARgin<n>:PTRansition** <SumBit>,<ChannelName>  
**STATus:QUESTIONable:POWER:PTRansition** <SumBit>,<ChannelName>  
**STATus:QUESTIONable:TEMPerature:PTRansition** <SumBit>,<ChannelName>  
**STATus:QUESTIONable:TRANsducer:PTRansition?** <SumBit>,<ChannelName>  
**STATus:QUESTIONable:TIME:PTRansition** <SumBit>,<ChannelName>

These commands control the Positive TRansition part of a register.

Setting a bit causes a 0 to 1 transition in the corresponding bit of the associated register. The transition also writes a 1 into the associated bit of the corresponding EVENT register.

**Suffix:**

<n> [Window](#)

**Parameters:**

<SumBit> Range: 0 to 65535

<ChannelName> String containing the name of the channel.  
 The parameter is optional. If you omit it, the command works for the currently active channel.

## 13.11 Service Request

The service request routine requires an extended initialization of the instrument in which the relevant bits of the transition and enable registers are set. In addition the service request event must be enabled in the VISA session.

### 13.11.1 Initiate Service Request

```

REM ---- Example of initialization of the SRQ in the case
' of errors -----
PUBLIC SUB SetupSRQ()
CALL InstrWrite (analyzer, "*CLS") 'Reset status reporting system
CALL InstrWrite (analyzer, "*SRE 168") 'Enable service request for
' STAT:OPER, STAT:QUES and ESR
' register
CALL InstrWrite (analyzer, "*ESE 60") 'Set event enable bit for
' command, execution, device-
' dependent and query error
CALL InstrWrite (analyzer, "STAT:OPER:ENAB 32767")
' Set OPERATION enable bit for
' all events
CALL InstrWrite (analyzer, "STAT:OPER:PTR 32767")
' Set appropriate OPERATION
' Ptransition bits
CALL InstrWrite (analyzer, "STAT:QUES:ENAB 32767")
' Set questionable enable bits
' for all events
CALL InstrWrite (analyzer, "STAT:QUES:PTR 32767")
' Set appropriate questionable
' Ptransition bits
CALL viEnableEvent(analyzer, VI_EVENT_SERVICE_REQ, VI_QUEUE, 0)
' Enable the event for service
' request
Status = viWaitOnEvent(analyzer, VI_EVENT_SERVICE_REQ, SRQWaitTimeout, VI_NULL,
VI_NULL)
IF (status = VI_SUCCESS) THEN CALL Srq
' If SRQ is recognized =>
' subroutine for evaluation
END SUB
REM *****

```

### 13.11.2 Waiting for the Arrival of a Service Request

There are basically two methods of waiting for the arrival of a service request:

**Blocking (user inputs not possible):**

This method is appropriate if the waiting time until the event to be signaled by an SRQ is short (shorter than the selected timeout), if no response to user inputs is required during the waiting time, and if – as the main criterion – the event is absolutely certain to occur.

Reason:

From the time the `viWaitOnEvent()` function is called until the occurrence of the expected event, it does not allow the program to respond to mouse clicks or key entries during the waiting time. Moreover, it returns an error if the SRQ event does not occur within the predefined timeout period.

The method is, therefore, in many cases not suitable for waiting for measurement results, especially when using triggered measurements.

The following function calls are required:

```
Status = viWaitOnEvent(analyzer, VI_EVENT_SERVICE_REQ, SRQWaitTimeout, VI_NULL,
    VI_NULL)
'Wait for service request user
'inputs are not possible during
'the waiting time!
IF (status = VI_SUCCESS) THEN CALL Srq
'If SRQ is recognized =>
'subroutine for evaluation

'----- Sweep in first Spectrum Tab and query marker -----
Dim Status = mbSession.WaitOnEvent( _
MessageBasedSessionEventType.ServiceRequest, SRQWaitTimeout)
'Wait for service request user inputs are not possible
'during the waiting time!
If (Status.EventType() = MessageBasedSessionEventType.ServiceRequest) Then
'If SRQ is recognized => subroutine for evaluation
    Srq()
End If
```

**Non-blocking (user inputs possible):**

This method is recommended if the waiting time until the event to be signaled by an SRQ is long (longer than the selected timeout), and user inputs should be possible during the waiting time, or if the event is not certain to occur. This method is, therefore, the preferable choice for waiting for the end of measurements, i.e. the output of results, especially in the case of triggered measurements.

The method necessitates a waiting loop that checks the status of the SRQ line at regular intervals and returns control to the operating system during the time the expected event has not yet occurred. In this way, the system can respond to user inputs (mouse clicks, key entries) during the waiting time.

It is advisable to employ the `Hold()` auxiliary function, which returns control to the operating system for a selectable waiting time (see section [Waiting Without Blocking the Keyboard and Mouse](#)), so enabling user inputs during the waiting time.

```

result% = 0
For i = 1 To 10 'Abort after max. 10 loop
'iterations
Status = viWaitOnEvent(analyzer, VI_EVENT_SERVICE_REQ, VI_TMO_IMMEDIATE, VI_NULL,
VI_NULL)
'Check event queue
If (status = VI_SUCCESS) Then
result% = 1
CALL Srq 'If SRQ is recognized =>
'subroutine for evaluation
Else
CALL Hold(20) 'Call hold function with
'20 ms 'waiting time. User inputs
'are possible.
Endif
Next i
If result% = 0 Then
Debug.Print "Timeout Error; Program aborted" 'Output error message
STOP 'Stop software
Endif

```

### 13.11.3 Waiting Without Blocking the Keyboard and Mouse

A frequent problem with remote control programs using Visual Basic is to insert waiting times without blocking the keyboard and the mouse.

If the program is to respond to user inputs also during a waiting time, control over the program events during this time must be returned to the operating system. In Visual Basic, this is done by calling the `DoEvents` function. This function causes keyboard-or mouse-triggered events to be executed by the associated elements. For example, it allows the operation of buttons and input fields while the user waits for an instrument setting to be completed.

The following programming example describes the `Hold()` function, which returns control to the operating system for the period of the waiting time selectable in milliseconds.

```

Rem *****
Rem The waiting function below expects the transfer of the desired
Rem waiting time in milliseconds. The keyboard and the mouse remain
Rem operative during the waiting period, thus allowing desired elements
Rem to be controlled
Rem *****
Public Sub Hold(delayTime As Single)
Start = Timer 'Save timer count on calling the
'function
Do While Timer < Start + delayTime/1000 'Check timer count
DoEvents 'Return control to operating
'system to enable control of
'desired elements as long as

```

```
'timer has not elapsed
Loop
End Sub
Rem *****
```

The waiting procedure is activated simply by calling Hold(<Waiting time in milliseconds>).

### 13.11.4 Service Request Routine

A service request is processed in the service request routine.



The variables userN% and userM% must be pre-assigned usefully!

```
REM ----- Service request routine -----
Public SUB Srq()
ON ERROR GOTO noDevice 'No user existing
CALL viReadSTB(analyzer, STB%) 'Serial poll, read status byte
IF STB% > 0 THEN 'This instrument has bits set in
'the STB
SRQFOUND% = 1
IF (STB% AND 16) > 0 THEN CALL Outputqueue
IF (STB% AND 4) > 0 THEN CALL ErrorQueueHandler
IF (STB% AND 8) > 0 THEN CALL Questionablestatus
IF (STB% AND 128) > 0 THEN CALL Operationstatus
IF (STB% AND 32) > 0 THEN CALL Esrread
END IF
noDevice:
END SUB 'End of SRQ routine
REM *****

REM ----- Subroutine for evaluation Service Request Routine -----

Public Sub Srq()
Try
Dim mySTB As Short = mbSession.ReadStatusByte()
'Serial poll, read status byte
Console.WriteLine("Reading Service Request Routine:" + mySTB.ToString())
If mySTB > 0 Then 'This instrument has bits set in the STB
If (mySTB And 16) > 0 Then Call Outputqueue()
If (mySTB And 4) > 0 Then Call ErrorQueueHandler()
If (mySTB And 8) > 0 Then Call Questionablestatus()
If (mySTB And 128) > 0 Then Call Operationstatus()
If (mySTB And 32) > 0 Then Call Esrread()
End If
Catch exp As Exception
Console.WriteLine(exp.Message)
```

```

    End Try
End Sub 'End of SRQ routine

```

Reading out the status event registers, the output buffer and the error/event queue is effected in subroutines.

### 13.11.5 Reading Out the Output Buffer

```

REM ----- Subroutine for the individual STB bits -----
Public SUB Outputqueue() 'Reading the output buffer
result$ = SPACE$(100) 'Make space for response
CALL InstrRead(analyzer, result$)
Debug.Print "Contents of Output Queue:"; result$
END SUB
REM *****

REM ----- Subroutine for the output queue -----
Public Sub Outputqueue() 'Reading the output buffer
    Try
        Dim result As String = mbSession.ReadString()
        Console.WriteLine("Contents of Output Queue:" + result)
    Catch exp As Exception
        Console.WriteLine(exp.Message)
    End Try
End Sub

```

### 13.11.6 Reading Error Messages

```

REM ----- Subroutine for reading the error queue -----
Public SUB ErrorQueueHandler()
ERROR$ = SPACE$(100) 'Make space for error variable
CALL InstrWrite (analyzer, "SYSTEM:ERROR?")
CALL InstrRead(analyzer, ERROR$)
Debug.Print "Error Description:"; ERROR$
END SUB
REM *****

REM ----- Subroutine for reading the error queue -----
Sub ErrorQueueHandler()
    Dim result As String
    Dim hasErr As Boolean = True
    Do
        mbSession.Write("SYST:ERR?")
        result = mbSession.ReadString()
        Dim parts As String() = result.Split(",")
        If parts(0) = 0 Then
            hasErr = False
            Console.WriteLine(result)
        Else

```



```

        Console.WriteLine(result)
    End If
    Loop While hasErr
End Sub

```

### 13.11.7 Evaluation of SCPI Status Registers

```

REM ----- Subroutine for evaluating Questionable Status Register -----
Public SUB Questionablestatus()
Ques$ = SPACE$(20)
'Preallocate blanks to text
'variable
CALL InstrWrite (analyzer, "STaTus:QUEStionable:EvEnt?")
CALL InstrRead(analyzer, Ques$)
Debug.Print "Questionable Status: "; Ques$
END SUB
REM *****
REM ----- Subroutine for evaluating Operation Status Register -----
Public SUB Operationstatus()
Oper$ = SPACE$(20) 'Preallocate blanks to text
'variable
CALL InstrWrite (analyzer, "STaTus:OPERation:EvEnt?")
CALL InstrRead(analyzer, Oper$)
Debug.Print "Operation Status: "; Oper$
END SUB
REM *****

REM ----- Subroutine for evaluating Questionable Status Register -----
Public Sub Questionablestatus()
    Dim myQSR As String = Nothing
    Try
        myQSR = mbSession.Query("STaTus:QUEStionable:EvEnt?") 'Read QSR
        Console.WriteLine("Questionable Status:" + myQSR)
    Catch exp As Exception
        Console.WriteLine(exp.Message)
    End Try
End Sub

REM ----- Subroutine for evaluating Operation Status Register -----
Public Sub Operationstatus()
    Dim myOSR As String = Nothing
    Try
        myOSR = mbSession.Query("STaTus:OPERation:EvEnt?") 'Read OSR
        Console.WriteLine("Operation Status:" + myOSR)
    Catch exp As Exception
        Console.WriteLine(exp.Message)
    End Try
End Sub

```

### 13.11.8 Evaluation of Event Status Register

```

REM ----- Subroutine for evaluating the Event Status Register -----
Public SUB Esrread()
Esr$ = SPACE$(20) 'Preallocate blanks to text
'variable
CALL InstrWrite (analyzer, "*ESR?") 'Read ESR
CALL InstrRead(analyzer, Esr$)
IF (VAL(Esr$) AND 1) > 0 THEN Debug.Print "Operation complete"
IF (VAL(Esr$) AND 2) > 0 THEN Debug.Print "Request Control"
IF (VAL(Esr$) AND 4) > 0
THEN Debug.Print "Query Error"
IF (VAL(Esr$) AND 8) > 0
THEN Debug.Print "Device dependent error"
IF (VAL(Esr$) AND 16) > 0
THEN Debug.Print "Execution Error; Program aborted" 'Output error message
STOP 'Stop software
END IF
IF (VAL(Esr$) AND 32) > 0
THEN Debug.Print "Command Error; Program aborted" 'Output error message
STOP 'Stop software
END IF
IF (VAL(Esr$) AND 64) > 0 THEN Debug.Print "User request"
IF (VAL(Esr$) AND 128) > 0 THEN Debug.Print "Power on"END SUB
REM *****

REM ----- Subroutine for evaluating the Event Status Register -----
Public Sub Esrread()
    Try
        Dim myESR As Short = mbSession.Query("*ESR?") 'Read ESR
        If (myESR And 1) > 0 Then Console.WriteLine("Operation complete")
        If (myESR And 2) > 0 Then Console.WriteLine("Request Control")
        If (myESR And 4) > 0 Then Console.WriteLine("Query Error")
        If (myESR And 8) > 0 Then Console.WriteLine("Device dependent error")
        If (myESR And 16) > 0 Then
            Console.WriteLine("Execution Error; Program aborted") 'Output error message
            Stop 'Stop software
        End If
        If (myESR And 32) > 0 Then
            Console.WriteLine("Command Error; Program aborted") 'Output error message
            Stop 'Stop software
        End If
        If (myESR And 64) > 0 Then Console.WriteLine("User request")
        If (myESR And 128) > 0 Then Console.WriteLine("Power on")
    Catch exp As Exception
        Console.WriteLine(exp.Message)
    End Try
End Sub

```

## 13.12 Reference: GPIB Commands of Emulated HP Models

The R&S ESW analyzer family supports a subset of the GPIB commands of HP models 8560E, 8561E, 8562E, 8563E, 8564E, 8565E, 8566A, 8566B, 8568A, 8568B and 8594E.

Despite the differences in system architecture and device features, the supported commands have been implemented in a way to ensure a sufficiently high degree of correspondence with the original.

This includes the support of syntax rules for not only newer device families (B and E models) but for the previous A family as well.

In many cases the selection of commands supported by the R&S ESW is sufficient to run an existing GPIB program without adaptation.

After the introduction, this section includes the following topics:

- [Command Set of Models 8560E, 8561E, 8562E, 8563E, 8564E, 8565E, 8566A/B, 8568A/B, 8591E, 8594E, 71100C, 71200C, and 71209A](#)..... 676
- [Special Features of the Syntax Parsing Algorithms for 8566A and 8568A Models](#) ..... 700
- [Special Behavior of Commands](#)..... 701
- [Model-Dependent Default Settings](#)..... 702
- [Data Output Formats](#)..... 703
- [Trace Data Output Formats](#)..... 703
- [Trace Data Input Formats](#)..... 703
- [GPIB Status Reporting](#)..... 703

### 13.12.1 Command Set of Models 8560E, 8561E, 8562E, 8563E, 8564E, 8565E, 8566A/B, 8568A/B, 8591E, 8594E, 71100C, 71200C, and 71209A

As with the original units, the R&S ESW includes the command set of the A models in the command set of the B models.



The HP model 8591E is compatible to HP model 8594E, the HP models 71100C, 71200C, and 71209A are compatible to HP models 8566A/B.

Command	Supported subset	Function	Corresp. HP-Models	Status
A1	A1	Clear/Write A	HP 8566A/ HP 8568A	available
A2	A2	Max Hold A	HP 8566A/ HP 8568A	available
A3	A3	View A	HP 8566A/ HP 8568A	available

Command	Supported subset	Function	Corresp. HP-Models	Status
A4	A4	Blank A	HP 8566A/ HP 8568A	available
ABORT <sup>1)</sup>	ABORT	Stop previous function	HP 856xE/ HP 8566B/HP 8568B/HP 8594E	available
ADD		Add	HP 8566B/ HP 8568B/ HP 8594E	available
ADJALL	ADJALL	Adjust all	HP 856xE/ HP 8566B/ HP 8568B/ HP 8594E	available
ADJCRT <sup>2)</sup>	ADJCRT	Adjust CRT	HP 856xE/ HP 8566B/ HP 8568B/ HP 8594E	available
ADJIF <sup>2)</sup>	ADJIF	Auto adjust IF	HP 856xE/ HP 8566B/ HP 8568B/ HP 8594E	available
AMB	AMB ON OFF AMB 1 0 AMB?	Trace A – B -> Trace A	HP 856xE/ HP 8594E	available
AMBPL	AMBPL ON OFF AMBPL 1 0 AMBPL?		HP 856xE/ HP 8566B/ HP 8568B/ HP 8594E	available
ANNOT	ANNOT ON OFF ANNOT 1 0 ANNOT?	Annotation	HP 856xE/ HP 8566B/ HP 8568B/ HP 8594E	available
APB	APB	Trace A + B -> Trace A	HP 856xE/ HP 8566B/ HP 8568B/ HP 8594E	available

Command	Supported subset	Function	Corresp. HP-Models	Status
AT	AT <numeric_value> DB   DM AT DN AT UP AT AUTO AT?	Attenuation	HP 8566A/ HP 8568A/ HP 856xE/ HP 8566B/ HP 8568B/ HP 8594E	available
AUNITS	AUNITS DBM   DBMV   DBUV   AUNITS?	Amplitude Units	HP 856xE/ HP 8566B/ HP 8568B/ HP 8594E	available
AUTOCP	AUTOCP	Coupling default	HP 856xE/ HP 8566B/ HP 8568B/ HP 8594E	available
AXB	AXB	Exchange trace A and B	HP 856xE/ HP 8566B/ HP 8568B/ HP 8594E	available
B1	B1	Clear/Write B	HP 8566A/ HP 8568A	available
B2	B2	Max Hold B	HP 8566A/ HP 8568A	available
B3	B3	View B	HP 8566A/ HP 8568A	available
B4	B4	Blank B	HP 8566A/ HP 8568A	available
BL	BL	Trace B – Display Line - > Trace B	HP 8566A/ HP 8568A	available
BML	BML	Trace B – Display Line - > Trace B	HP 856xE/ HP8594E	available
BTC	BTC	Transfer Trace B -> C	HP 856xE/ HP 8566B/ HP 8568B/ HP 8594E	available
BXC	BXC	Exchange Trace B and C	HP 856xE/ HP 8566B/ HP 8568B/ HP 8594E	available

Command	Supported subset	Function	Corresp. HP-Models	Status
BLANK	BLANK TRA TRB TRC	Blank Trace	HP 856xE/ HP 8566B/ HP 8568B/ HP 8594E	available
C1	C1	A-B off	HP 8566A/ HP 8568A	available
C2	C2	A-B -> A	HP 8566A/ HP 8568A	available
CA	CA	Couple Attenuation	HP 8566A/ HP 8568A	available
CAL <sup>1)</sup>	CAL ALL CAL ON CAL OFF	Start analyzer self alignment	HP 856xE/ HP 8566B/ HP 8568B/ HP 8594E	available
CF	CF <numeric_value> HZ KHZ MHZ GHZ CF UP CF DN CF?	Center Frequency	HP 8566A/ HP 8568A/ HP 856xE/ HP 8566B/ HP 8568B/ HP 8594E	available
CHANPWR	CHANPWR TRA TRB, <numeric_value> ,?	Channel Power Measurement	HP 856xE/ HP 8594E	available
CHPWRBW	CHPWRBW <numeric_value> HZ  KHZ MHZ GHZ	Channel Power Bandwidth	HP 856xE/ HP 8594E	available
CLRW	CLRW TRA TRB TRC	Clear/Write Trace	HP 856xE/ HP 8566B/ HP 8568B/ HP 8594E	available
CLS <sup>1)</sup>	CLS	Clear all status bits	HP 856xE/ HP 8566B/ HP 8568B/ HP 8594E	available
CONTS	CONTS		HP 856xE/ HP 8566B/ HP 8568B/ HP 8594E	available

Command	Supported subset	Function	Corresp. HP-Models	Status
COUPLE	COUPLE AC DC	Input coupling	HP 856xE/ HP 8566B/ HP 8568B/ HP 8594E	available
CR	CR	Couple RBW	HP 8566A/ HP 8568A	available
CS	CS	Couple Step Size	HP 8566A/ HP 8568A	available
CT	CT	Couple SWT	HP 8566A/ HP 8568A	available
CTA		Convert to absolute units	HP 8566B/ HP 8568B/ HP 8594E	available
CV	CV	Couple VBW	HP 8566A/ HP 8568A	available
D1 <sup>2)</sup>	D1	Display Size normal	HP 8566A/ HP 8568A	available
DA <sup>2)</sup>	DA	Display address		available
DEMOMD <sup>1)</sup>	DEMOMD ON OFF AM  FM	AF Demodulator	HP 856xE/ HP 8566B/ HP 8568B/ HP 8594E	available
DEMOMDAGC <sup>2)</sup>	DEMOMDAGC ON OFF 1  0 DEMOMDAGC?	Demodulation AGC	HP 856xE/ HP 8566B/ HP 8568B/ HP 8594E	available
DEMOMDT	DEMOMDT <numeric_value> S MS  US SC DEMOMDT UP DN DEMOMDT?	Demodulation time	HP 856xE/ HP 8566B/ HP 8568B/ HP 8594E	available
DET	DET POS SMP NEG DET?	Detector	HP 856xE/ HP 8566B/ HP 8568B/ HP 8594E	available
DISPOSE <sup>2)</sup>	ONEOS   TRMATH   ONSWP   ALL   <numeric_value>			available

Command	Supported subset	Function	Corresp. HP-Models	Status
DIV		Divide	HP 8566B/ HP 8568B/ HP 8594E	available
DL	DL <numeric_value> DB DM DL DN DL UP DL ON DL OFF DL?	Display Line	HP 856xE/ HP 8566B/ HP 8568B/ HP 8594E	available
DLE	DLE ON OFF	Display Line enable	HP 856xE/ HP 8566B/ HP 8568B/ HP 8594E	available
DONE	DONE DONE?	Done query	HP 856xE/ HP 8566B/ HP 8568B/ HP 8594E	available
DW <sup>2)</sup>	DW	Write to display and increment address		available
E1	E1	Peak Search	HP 8566A/ HP 8568A	available
E2	E2	Marker to Center Freq.	HP 8566A/ HP 8568A	available
E3	E3	Deltamarker Step Size	HP 8566A/ HP 8568A	available
E4	E4	Marker to Ref. Level	available	available
EDITDONE		limit line edit done	HP 856xE	available
EDITLIML		edit limit line	HP 856xE	available



Command	Supported subset	Function	Corresp. HP-Models	Status
ERR	ERR 250 cal level error ERR 300 LO unlock ERR 472 cal error digital filter ERR 473 cal error analog filter ERR 552 cal error log amp ERR 902 unscale tracking generator ERR 906 oven cold ERR 117 numeric unit error ERR 112 Unrecognized Command	Now some FSx errors are mapped to HP errors.	HP8568A HP856xE	not yet available
ERR?	ERR?	Error queue query	HP 856xE/ HP 8566B/ HP 8568B/ HP 8594E	not yet available
EX	EX	Exchange trace A and B	HP 8566A/ HP 8568A	available
FA	FA <numeric_value> HZ  KHZ MHZ GHZ FA UP FA DN FA?	Start Frequency	HP 8566A/ HP 8568A/ HP 856xE/ HP 8566B/ HP 8568B/ HP 8594E	available
FB	FB <numeric_value> HZ  KHZ MHZ GHZ FB UP FB DN FB?	Stop Frequency	HP 8566A/ HP 8568A/ HP 856xE/ HP 8566B/ HP 8568B/ HP 8594E	available
FDSP		Frequency display off	8560E 8561E 8562E 8563E 8564E 8565E	available
FOFFSET <sup>1)</sup>	FOFFSET <numeric_value> HZ  KHZ MHZ GHZ FOFFSET?	Frequency Offset	HP 856xE/ HP 8566B/ HP 8568B/ HP 8594E	available

Command	Supported subset	Function	Corresp. HP-Models	Status
FREF	FREF INT EXT	Reference Frequency	HP 856xE/ HP 8566B/ HP 8568B/ HP 8594E	available
FS	FS	Full Span	HP 8566A/ HP 8568A	available
FUNCDEF		Define Function Function must be in one line between delimiters @	HP 8594E/ HP 856xE/ HP 8566B	available
GATE <sup>1)</sup>	GATE ON OFF GATE 1 0		HP 856xE/ HP 8566B/ HP 8568B/ HP 8594E	available
GATECTL <sup>1)</sup>	GATECTL EDGE LEVEL GATECTL?		HP 856xE/ HP 8566B/ HP 8568B/ HP 8594E	available
GD <sup>1)</sup>	GD <numeric_value> US MS SC GD DN GD UP GD?		HP 856xE/ HP 8566B/ HP 8568B/ HP 8594E	available
GL <sup>1)</sup>	GL <numeric_value> US MS SC GL DN GL UP GL?		HP 856xE/ HP 8566B/ HP 8568B/ HP 8594E	available
GP <sup>1)</sup>	GP POS NEG GP?		HP 856xE/ HP 8566B/ HP 8568B/ HP 8594E	available
GRAT <sup>2)</sup>	GRAT ON OFF	Graticule	HP 856xE/ HP 8566B/ HP 8568B/ HP 8594E	available
I1	I1		HP 8566A/ HP 8568A	available
I2	I2		HP 8566A/ HP 8568A	available

Command	Supported subset	Function	Corresp. HP-Models	Status
ID	ID ID?	Identify	HP 8566A/ HP 8568A/ HP 856xE/ HP 8566B/ HP 8568B/ HP 8594E	available
INZ <sup>1)</sup>	INZ 75 INZ 50 INZ?	Input Impedance	HP 856xE/ HP 8566B/ HP 8568B/ HP 8594E	available
IP	IP	Instrument preset	HP 8566A/ HP 8568A	available
KEYDEF	KEYDEF	Key definition	HP 8566B/ HP 856xE/ HP 859xE	available
KEYEXEC	KEYEXEC	Key execute	HP 8566B	available
KS=	KS= <numeric_value> HZ KHZ MHZ GHZ KS= DN KS= UP KS=?	Marker Frequency Counter Resolution	HP 8566A/ HP 8568A	available
KS/	KS/	Manual Peaking	HP 8566A/ HP 8568A	available
KS(	KS(	Lock register	HP 8566A/ HP 8568A	available
KS)	KS)	Unlock register	HP 8566A/ HP 8568A	available
KS91	KS91	Read Amplitude Error	HP 8566A/ HP 8568A	available
KSA	KSA	Amplitude Units in dBm	HP 8566A/ HP 8568A	available
KSB	KSB	Amplitude Units in dBmV	HP 8566A/ HP 8568A	available
KSC	KSC	Amplitude Units in dBuV	HP 8566A/ HP 8568A	available
KSD	KSD	Amplitude Units in V	HP 8566A/ HP 8568A	available
KSE	KSE <numeric_value>  <char data>@	Title mode	HP 8566A/ HP 8568A	available

Command	Supported subset	Function	Corresp. HP-Models	Status
KSG	KSG KSG ON KSG <numeric_value>	Video Averaging on	HP 8566A/ HP 8568A	available
KSH	KSH	Video Averaging Off	HP 8566A/ HP 8568A	available
KSK		Marker to Next Peak	HP 8566A/ HP 8568A	available
KSL		Marker Noise off	HP 8566A/ HP 8568A	available
KSM		Marker Noise on	HP 8566A/ HP 8568A	available
KSO	KSO	Deltamarker to span	HP 8566A/ HP 8568A	available
KSP	KSP <numeric_value>	HPIB address	HP 8566A/ HP 8568A	available
KSQ <sup>2)</sup>	KSQ	Band lock off	HP 8566A/ HP 8568A	available
KST	KST	Fast Preset	HP 8566A/ HP 8568A	available
KSV	KSV <numeric_value> HZ KHZ MHZ GHZ KSV?	Frequency Offset	HP 8566A/ HP 8568A	available
KSW	KSW	Error Correction Routine	HP 8566A/ HP 8568A	available
KSX	KSX	Correction Values On	HP 8566A/ HP 8568A	available
KSY	KSY	Correction Values Off	HP 8566A/ HP 8568A	available
KSZ	KSZ <numeric_value> DB KSZ?	Reference Value Offset	HP 8566A/ HP 8568A	available
KSa	KSa	Normal Detection	HP 8566A/ HP 8568A	available
KSb	KSb	Pos Peak Detection	HP 8566A/ HP 8568A	available
KSd	KSd	Neg Peak Detection	HP 8566A/ HP 8568A	available

Command	Supported subset	Function	Corresp. HP-Models	Status
KSe	KSe	Sample Detection	HP 8566A/ HP 8568A	available
KSg		CRT beam off		available
KSh		CRT beam on		available
KSj	KSj	View Trace C	HP 8566A/ HP 8568A	available
KSk	KSk	Blank Trace C	HP 8566A/ HP 8568A	available
KSl	KSl	Transfer B to C	HP 8566A/ HP 8568A	available
KSm	KSm	Graticule off	HP 8566A/ HP 8568A	available
KSn <sup>2)</sup>	KSn	Grid on	HP 8566A/ HP 8568A	available
KSo	KSn	Character display off	HP 8566A/ HP 8568A	available
KSp	KSp	Character display on	HP 8566A/ HP 8568A	available
KSr	KSr	Create service request	HP 8566A/ HP 8568A	available
KSt <sup>2)</sup>	KSt	Band lock on	HP 8566A/ HP 8568A	available
KV <sup>2)</sup>	KV	Signal ident on	HP 8566A/ HP 8568A	available
L0	L0	Display line off	HP 8566A/ HP 8568A	available
LB	LB <numeric_value>  <char data>@	Label	HP 8566A/ HP 8568A	available
LF	LF	Low frequency band pre- set	HP 8566A/ HP 8568A	available
LIMD		limit line delta	HP 856xE	available
LIMF		limit line frequency	HP 856xE	available
LIMIFAIL		limit fail query	HP 856xE	available
LIMIPURGE		purge limit line	HP 856xE	available
LIMIRCL		recall limit line	HP 856xE	available
LIMIREL		relative limit line	HP 856xE	available

Command	Supported subset	Function	Corresp. HP-Models	Status
LIMISAV		save limit line	HP 856xE	available
LIMITEST		limit line test	HP 856xE	available
LIML		lower limit line value	HP 856xE	available
LIMM		middle limit line value	HP 856xE	available
LIMTFL		flat limit line segment	HP 856xE	available
LIMTSL		slope limit line segment	HP 856xE	available
LIMU		upper limit line value	HP 856xE	available
LG	LG <numeric_value> DB   DM LG?	Amplitude Scale Log	HP 856xE/ HP 8566B/ HP 8568B/ HP 8594E	available
LL <sup>2)</sup>	LL	Plot command	HP 8566A/ HP 8568A	available
LN	LN	Amplitude Scale Lin	HP 856xE/ HP 8566B/ HP 8568B/ HP 8594E	available
M1	M1	Marker Off	HP 8566A/ HP 8568A	available
M2	M2 M2 <numeric_value> HZ KHZ MHZ GHZ M2 DN M2 UP M2?	Marker Normal	HP 8566A/ HP 8568A	available
M3	M3 M3 <numeric_value> HZ KHZ MHZ GHZ M3 DN M3 UP M3?	Delta Marker	HP 8566A/ HP 8568A	available
M4	M4 <numeric_value> HZ KHZ MHZ GHZ	Marker Zoom	HP 8566A/ HP 8568A	available
MA	MA	Marker Amplitude	HP 8566A/ HP 8568A	available
MC0	MC0	Marker Count off	HP 8566A/ HP 8568A	available

Command	Supported subset	Function	Corresp. HP-Models	Status
MC1	MC1	Marker Count on	HP 8566A/ HP 8568A	available
MDS	MDS	Measurement data size	HP 8566B	available
MEAS		Measurement status	HP 856xE	available
MF	MF MF?	Marker Frequency	HP 8566A/ HP 8568A/ HP 856xE/ HP 8566B/ HP 8568B/ HP 8594E	available
MINH <sup>1)</sup>	MINH TRC	Minimum Hold	HP 856xE/ HP 8566B/ HP 8568B/ HP 8594E	available
MKA	MKA <numeric_value> MKA?	Marker Amplitude	HP 856xE/ HP 8566B/ HP 8568B/ HP 8594E	available
MKACT	MKACT 1 MKACT?	Select the active marker	HP 856xE/ HP 8566B/ HP 8568B/ HP 8594E	not available
MKBW <sup>1)</sup>	MKBW <numeric_value> MKBW ON MKBW OFF	N dB Down	HP 856xE/ HP 8566B/ HP 8568B/ HP 8594E	available
MKD	MKD MKD <numeric_value> HZ KHZ  MHZ GHZ MKD DN MKD UP MKD ON MKD OFF MKD?	Delta Marker	HP 856xE/ HP 8566B/ HP 8568B/ HP 8594E	available
MKDR	MKDR <numeric_value> HZ KHZ  MHZ GHZ  S SC MS MSEC  USMKDR?	Delta Marker reverse	HP 856xE/ HP 8566B/ HP 8568B/ HP 8594E	available

Command	Supported subset	Function	Corresp. HP-Models	Status
MKDR?		Delta Marker reverse query		available
MKF	MKF <numeric_value> HZ KHZ MHZ GHZ MKF?	Set Marker Frequency	HP 856xE/ HP 8566B/ HP 8568B/ HP 8594E	available
MKFC	MKFC ON OFF	Frequency Counter on/off	HP 856xE/ HP 8566B/ HP 8568B/ HP 8594E	available
MKFCR <sup>1)</sup>	MKFCR <numeric_value> HZ KHZ  MHZ GHZ MKFCR DN MKFCR UP MKFCR?	Frequency Counter Resolution	HP 856xE/ HP 8566B/ HP 8568B/ HP 8594E	available
MKMIN	MKMIN	Marker -> Min	HP 856xE/ HP 8566B/ HP 8568B/ HP 8594E	available
MKN	MKN MKN <numeric_value> HZ KHZ MHZ GHZ MKN DN MKN UP MKN ON MKN OFF MKN?	Normal Marker	HP 856xE/ HP 8566B/ HP 8568B/ HP 8594E	available
MKNOISE	MKNOISE ON OFF MKNOISE 1 0 MKNOISE?	Noise Measurement	HP 856xE/ HP 8566B/ HP 8568B/ HP 8594E	available
MKOFF	MKOFF MKOFF ALL	Marker off	HP 856xE/ HP 8566B/ HP 8568B/ HP 8594E	available
MKP	MKP <numeric_value> MKP?	Marker position	HP 856xE/ HP 8566B/ HP 8568B/ HP 8594E	available



Command	Supported subset	Function	Corresp. HP-Models	Status
MKPK	MKPK MKPK HI MKPK NH MKPK NR MKPK NL	Marker Search	HP 856xE/ HP 8566B/ HP 8568B/ HP 8594E	available
MKPT	MKPT MKPT HI MKPT NH MKPT NR MKPT NL	Marker Peak Threshold	HP 856xE/ HP 8566B/ HP 8568B/ HP 8594E	available
MKPX	MKPX <numeric_value> DB MKPX DN MKPX UP MKPX?	Peak Excursion	HP 856xE/ HP 8566B/ HP 8568B/ HP 8594E	available
MKRL	MKRL	Ref Level = Marker Level	HP 856xE/ HP 8566B/ HP 8568B/ HP 8594E	available
MKSP	MKSP	Deltamarker to span	HP 856xE/ HP 8566B/ HP 8568B/ HP 8594E	available
MKSS	MKSS	CF Stepsize = Marker Freq	HP 856xE/ HP 8566B/ HP 8568B/ HP 8594E	available
MKT	MKT <numeric_value> S MS US SC MKT?	$MKF = f_{start} + MKT / SWT * Span$	HP 856xE/ HP 8594E	available
MKTRACE	MKTRACE TRA TRB  TRC	Marker to Trace	HP 856xE/ HP 8566B/ HP 8568B/ HP 8594E	available
MKTRACK	MKTRACK ON OFF MKTRACK 1 0 MKTRACK?	Signal Track	HP 856xE/ HP 8566B/ HP 8568B/ HP 8594E	available

Command	Supported subset	Function	Corresp. HP-Models	Status
MKTYPE	MKTYPE AMP MK TYPE?	Marker type	HP 856xE/ HP 8566B/ HP 8568B/ HP 8594E	available
ML		Mixer level	HP 856xE	available
MOV	MOV TRA TRB TRC, TRA TRB T RC	Move Trace Contents	HP 856xE/ HP 8566B/ HP 8568B/ HP 8594E	available
MPY		Multiply	HP 8566B/ HP 8568B/ HP 8594E	available
MT0	MT0	Marker Track Off	HP 8566A/ HP 8568A	available
MT1	MT1	Marker Track On	HP 8566A/ HP 8568A	available
MXMH	MXMH TRA TRB	Maximum Hold	HP 856xE/ HP 8566B/ HP 8568B/ HP 8594E	available
NORMALIZE	NORMALIZE	Normalize trace	HP 856xE/ HP 8566B/ HP 8568B/ HP 8594E	not available available
NRL <sup>1)</sup>	NRL <numeric_value> DB   DM NRL?	Normalized Reference Level	HP 856xE/ HP 8566B/ HP 8568B/ HP 8594E	available
NRPOS	NRPOS <numeric_value> NRL?	Normalize position	HP 856xE/ HP 8566B/ HP 8568B/ HP 8594E	available
O1	O1	Format ASCII, Values 0 to 4095	HP 8566A/ HP 8568A	available
O2	O2	Format Binary, Values 0 to 4095	HP 8566A/ HP 8568A	available
O3	O3	Format ASCII	HP 8566A/ HP 8568A	available

Command	Supported subset	Function	Corresp. HP-Models	Status
OA	OA	Output All	HP 8566A/ HP 8568A	available
OL	OL <80 characters> OL?	Output Learn String	HP 8566A/ HP 8568A	available
OT	OT	Output Trace Annotations	HP 8566A/ HP 8568A	available
PA	PA <numeric_value>, <numeric_value	Plot command	HP 8566A/ HP 8568A	available
PD	PD <numeric_value>, <numeric_value	Plot command	HP 8566A/ HP 8568A	available
PH_MKF		Spot frequency in Hz	HP 856xE	available
PH_FMIN		Min offset frequency to be measured	HP 856xE	available
PH_FMAX		Max offset frequency to be measured	HP 856xE	available
PH_MKA		Queries amplitude at the spot frequency	HP 856xE	available
PH_DRIFT		0: for stable signals, 1: for drifty	HP 856xE	available
PH_RLVL		Reference level for the log plot	HP 856xE	available
PH_SMTHV		Trace smoothing	HP 856xE	available
PH_VBR		Filtering	HP 856xE	available
PH_RMSPT		Amount of data points to skip when doing the integration	HP 856xE	available
PH_RMSFL		Lower integration frequency in Hz	HP 856xE	available
PH_RMSFU		Upper integration frequency in Hz	HP 856xE	available
PH_EXIT		Quits phase noise	HP 856xE	available
PH_F_UDT		Updates internal frequency variables	HP 856xE	available
PH_LMT_L		Apply limits to PH_FMIN and PH_FMAX	HP 856xE	available
PH_MEAS		Generates log frequency plot	HP 856xE	available
PH_MKF_D		Updates the spot frequency	HP 856xE	available

Command	Supported subset	Function	Corresp. HP-Models	Status
PH_RMS		Requests the rms phase noise	HP 856xE	available
PH_RMSFT		Updates internal frequency variables	HP 856xE	available
PH_RMSX		Calculates the rms phase noise	HP 856xE	available
PH_SPOTF		Executes the spot frequency measurement	HP 856xE	available
PLOTORG <sup>2)</sup>	PLOTORG DSP GRT	Plot command	HP 856xE/ HP 8566B/ HP 8568B/ HP 8594E	available
PLOTSRC <sup>2)</sup>	PLOTSRC ANNT GRT  TRB  TRA ALLDSP GRT	Plot command	HP 856xE/ HP 8566B/ HP 8568B/ HP 8594E	available
PP	PP	Preselector Peaking	HP 8566A/ HP 8568A	available
PRINT <sup>1)</sup>	PRINT PRINT 1 0	Hardcopy	HP 856xE/ HP 8566B/ HP 8568B/ HP 8594E	available
PSDAC <sup>2)</sup>	PSDAC <numeric_value> PSDAC UP DN	Preselector DAC value	HP 856xE/ HP 8566B/ HP 8568B/ HP 8594E	available
PSTATE <sup>2)</sup>	PSTATE ON OFF 1 0	Protect State	HP 856xE/ HP 8566B/ HP 8568B/ HP 8594E	available
PU	PU	Pen Up	HP 8566A/ HP 8568A	available
PWRBW	PWRBW	Power Bandwidth	HP 8566B/ HP 859x/ HP 856xE	available
R1	R1	Set Status Bit Enable	HP 8566A/ HP 8568A	available
R2	R2	Set Status Bit Enable	HP 8566A/ HP 8568A	available

Command	Supported subset	Function	Corresp. HP-Models	Status
R3	R3	Set Status Bit Enable	HP 8566A/ HP 8568A	available
R4	R4	Set Status Bit Enable	HP 8566A/ HP 8568A	available
RB	RB <numeric_value> HZ KHZ MHZ GHZ RB DN RB UP RB AUTO RB?	Resolution Bandwidth	HP 856xE/ HP 8566B/ HP 8568B/ HP 8594E	available
RBR	RBR <numeric_value> RBR DN RBR UP RBR?	Resolution Bandwidth Ratio	HP 856xE/ HP 8566B/ HP 8568B/ HP 8594E	available
RC1...6	RC1...6	Recall Last State	HP 8566A/ HP 8568A	available
RCLS	RCLS <numeric_value>	Recall State Register	HP 856xE/ HP 8566B/ HP 8568B/ HP 8594E	available
RCLT	RCLT TRA TRB, <number>	Recall Trace	HP856xE/ HP8594E	available
RESET	RESET	Instrument preset	HP 856xE/ HP 8566B/ HP 8568B/ HP 8594E	available
REV	REV REV?	Firmware revision	HP 856xE/ HP 8566B/ HP 8568B/ HP 8594E	available
RL	RL <numeric_value> DB DM RL DN RL UP RL?	Reference Level	HP 856xE/ HP 8566B/ HP 8568B/ HP 8594E	available
RLCAL	RLCAL <numeric_value> RL?	Reference Level Calibration	HP 856xE/ HP 8566B/ HP 8568B/ HP 8594E	available

Command	Supported subset	Function	Corresp. HP-Models	Status
RCLOSCAL	RCLOSCAL	Recall Open/Short Average	HP 856xE/ HP 8594E	not available
RCLTHRU	RCLTHRU	Recall Thru	HP 856xE/ HP 8594E	not available
RLPOS <sup>1)</sup>	RLPOS <numeric_value> RLPOS DN RLPOS UP RLPOS?	Reference Level Position	HP 856xE/ HP 8566B/ HP 8568B/ HP 8594E	available
ROFFSET	ROFFSET <numeric_value> DB   DM ROFFSET?	Reference Level Offset	HP 856xE/ HP 8566B/ HP 8568B/ HP 8594E	available
RQS	RQS	Service Request Bit mask	HP 856xE/ HP 8566B/ HP 8568B/ HP 8594E	available
S1	S1	Continuous Sweep	HP 8566A/ HP 8568A	available
S2	S2	Single Sweep	HP 8566A/ HP 8568A	available
SADD		add a limit line segment	HP 856xE	available
SAVES	SAVES <numeric_value>	Save State Register	HP 856xE/ HP 8566B/ HP 8568B/ HP 8594E	available
SAVET	SAVET TRA TRB,<number>	Save Trace	HP856xE/ HP8594E	available
SDEL		delete limit line segment	HP 856xE	available
SDON		limit line segment done	HP 856xE	available
SEDI		edit limit line segment	HP 856xE	available
SMOOTH	SMOOTH TRA TRB  TRC, <number of points>	Smooth Trace	HP 856xE/ HP 8566B/ HP 8568B/ HP 8594E	available
SNGLS	SNGLS	Single Sweep	HP 856xE/ HP 8566B/ HP 8568B/ HP 8594E	available

Command	Supported subset	Function	Corresp. HP-Models	Status
SQUELCH <sup>2)</sup>	SQUELCH <numeric_value> DM   DB SQUELCH UP DN SQUELCH ON OFF	Squelch	HP 856xE/ HP 8566B/ HP 8568B/ HP 8594E	available
SP	SP <numeric_value> HZ KHZ MHZ GHZ SP DN SP UP SP?	Span	HP 8566A/ HP 8568A/ HP 856xE/ HP 8566B/ HP 8568B/ HP 8594E	available
SRCNORM <sup>1)</sup>	SRCNORM ON OFF SRCNORM 1 0	Source Normalization	HP 856xE/ HP 8566B/ HP 8568B/ HP 8594E	not available
SRCPOFS <sup>1)</sup>	SRCPOFS <numeric_value> DB   DM SRCPOFS DN SRCPOFS UP SRCPOFS?	Source Power Offset	HP 856xE/ HP 8566B/ HP 8568B/ HP 8594E	not available
SRCPWR <sup>1)</sup>	SRCPWR <numeric_value> DB   DM SRCPWR DN SRCPWR UP SRCPWR ON SRCPWR OFF SRCPWR?	Source Power	HP 856xE/ HP 8566B/ HP 8568B/ HP 8594E	not available
SS	SS <numeric_value> HZ KHZ MHZ GHZ SS DN SS UP SS AUTO SS?	CF Step Size	HP 8566A/ HP 8568A/ HP 856xE/ HP 8566B/ HP 8568B/ HP 8594E	available
ST	ST <numeric_value> US MS SC ST DN ST UP ST AUTO ST?	Sweep Time	HP 8566A/ HP 8568A/ HP 856xE/ HP 8566B/ HP 8568B/ HP 8594E	available

Command	Supported subset	Function	Corresp. HP-Models	Status
STB	STB	Status byte query	HP 856xE/ HP 8566B/ HP 8568B/ HP 8594E	available
STOREOPEN	STOREOPEN	Store Open	HP 856xE/ HP 8594E	not available
STORESHORT	STORESHORT	Store Short	HP 856xE/ HP 8594E	not available
STORETHRU	STORETHRU	Store Thru	HP 856xE/ HP 8594E	not available
SUB		Subtract	HP 8566B/ HP 8568B/ HP 8594E	available
SUM		sum of trace amplitudes	HP 8566B/ HP 8568B/ HP 8594E	available
SV1...6	SV1...6	Save State	HP 8566A/ HP 8568A	available
SWPCPL <sup>2)</sup>	SWPCPL SA   SR SWPCPL?	Sweep Couple	HP 856xE/ HP 8566B/ HP 8568B/ HP 8594E	available
SWPOUT <sup>2)</sup>	SWPOUT FAV FAVA  RAMP SWPOUT?	Sweep Output	HP 856xE/ HP 8566B/ HP 8568B/ HP 8594E	available
T0	T0	Threshold off	HP 8566A/ HP 8568A	available
T1	T1	Free Run Trigger	HP 8566A/ HP 8568A	available
T2 <sup>2)</sup>	T2	Line Trigger	HP 8566A/ HP 8568A	available
T3	T3	External Trigger	HP 8566A/ HP 8568A	available
T4	T4	Video Trigger	HP 8566A/ HP 8568A	available
TA	TA	Transfer A	HP 8566A/ HP 8568A	available



Command	Supported subset	Function	Corresp. HP-Models	Status
TACL	TACL?	Returns instantaneous measurement results. See TRACe<trace #>:IMMediate:LEVel? for full description.		not available
TBCL	TBCL?			
TCCL	TCCL?			
TACR	TACR?	Returns instantaneous measurement results. See TRACe<trace #>:IMMediate:LEVel? for full description.		not available
TBCR	TBCR?			
TCCR	TCCR?			
TB	TB	Transfer B	HP 8566A/ HP 8568A	available
TDF	TDF P TDF M TDF B TDF A TDF I	Trace Data Format	HP 856xE/ HP 8566B/ HP 8568B/ HP 8594E	available
TH	TH <numeric_value> DB DM TH DN TH UP TH ON TH OFF TH AUTO TH?	Threshold	HP 856xE/ HP 8566B/ HP 8568B/ HP 8594E	available
THE	THE ON  OFF	Threshold Line enable	HP 856xE/ HP 8566B/ HP 8568B/ HP 8594E	available
TIMEDSP <sup>1)</sup>	TIMEDSP ON OFF TIMEDSP 1 0 TIMEDSP?	Time Display	HP 856xE/ HP 8566B/ HP 8568B/ HP 8594E	available
TM	TM FREE VID EXT  LINE <sup>2)</sup> TM?	Trigger Mode	HP 856xE/ HP 8566B/ HP 8568B/ HP 8594E	available
TM LINE <sup>2)</sup>	TM LINE	Trigger Line	HP 8566B	available

Command	Supported subset	Function	Corresp. HP-Models	Status
TRA	TRA B TRA A TRA I	Transfer A	HP 856xE/ HP 8566B/ HP 8568B/ HP 8594E	available
TRB	TRB B TRB A TRB I	Transfer B	HP 856xE/ HP 8566B/ HP 8568B/ HP 8594E	available
TRSTAT	TRSTAT?	Trace State Query	HP 856xE/ HP 8566B/ HP 8568B/ HP 8594E	available
TS	TS	Take Sweep	HP 856xE/ HP 8566B/ HP 8568B/ HP 8594E	available
UR <sup>2)</sup>	UR	Plot Command	HP 8566A/ HP 8568A	available
VARDEF	VARDEF	Variable definition, arrays are not supported	HP 8566B/ HP 8568B/ HP 8594E	available
VAVG	VAVG VAVG TRA TRB TRC	Video Averaging	HP 856xE/ HP 8566B/ HP 8568B/ HP 8594E	available
VB	VB <numeric_value> HZ KHZ MHZ GHZ VB DN VB UP VB AUTO VB?	Video Bandwidth	HP 856xE/ HP 8566B/ HP 8568B/ HP 8594E	available
VBR <sup>1)</sup>	VBR <numeric_value> VBR DN VBR UP VBR?	Video Bandwidth Ratio	HP 856xE/ HP 8566B/ HP 8568B/ HP 8594E	available
VIEW	VIEW TRA TRB TRC		HP 856xE/ HP 8566B/ HP 8568B/ HP 8594E	available

Command	Supported subset	Function	Corresp. HP-Models	Status
VTL	VTL <numeric_value> DB DM VTL DN VTL UP VTL?	Video Trigger Level	HP 856xE/ HP 8594E	not available
1) HP 8594E only				
2) Command is accepted without error message, but is ignored				

### 13.12.2 Special Features of the Syntax Parsing Algorithms for 8566A and 8568A Models

The command syntax is very different for models A and B. Different names are assigned to identical instrument functions, and the command structure likewise differs considerably between models A and models B.

The command structure for models A is as follows:

```
<command> ::= <command
code> [<SPC>] [<data> | <step>] [<SPC>] [<delimiter>] [<command
code>] ... <delimiter>
```

```
<data> ::= <Value> [<SPC>] [<units
code>] [<SPC>] [<delimiter>] [<SPC>] [<data>] ...
```

```
<step> ::= UP | DN
```

where

<command code> = see Table "Supported Commands"

<Value> = integer or floating-point numerical value

<units code> = DM | -DM | DB | HZ | KZ | MZ | GZ | MV | UV | SC | MS | US

<delimiter> = <CR> | <LF> | <, > | <; > | <ETX>

<SPC> = 32<sub>10</sub>

<ETX> = 3<sub>10</sub>

Command sections given in [ ] are optional.

The R&S ESW GPIB hardware differs from that used in the HP analyzers. Therefore, the following constraint exists:

<LF> | <EOI> are still used as delimiters since the GPIB hardware is able to identify them. The other delimiters are identified and evaluated during syntax analysis.

### 13.12.3 Special Behavior of Commands

Command	Known Differences
ABORT	Does not automatically set the command complete bit (bit 4) in the status byte. An additional DONE is required for that purpose.
ANNOT	Only frequency axis annotation is affected.
AT	AT DN/UP: Step size
CAL	The CAL commands do not automatically set the command complete bit (bit 4) in the status byte. An additional DONE command is required for that purpose.
CF	Default value, range, step size
CR	Default ratio Span/RBW
CT	Formula for coupled sweep time
CV	Default ratio RBW/VBW
DET	DET? returns SAMP instead of SMP on the R&S ESW. DET not automatically set the command complete bit (bit 4) in the status byte. An additional DONE is required for that purpose.
ERR?	Deletes the error bit in the status register but always returns a '0' in response.
FA	Default value, range, step size
FB	Default value, range, step size
ID	
M2	Default value, range, step size
M3	Default value, range, step size
MKACT	Only marker 1 is supported as the active marker.
MKBW	Default value
MKPT	Step size
MKPX	Step size
OL?	Storage of instrument settings: 80 characters are returned as information on the instrument settings. The contents of the 80 characters returned does not correspond to the original data contents of the 8566A/8568A family.
OL	Readout of instrument settings: The 80 characters read by means of OL? are accepted as information on the corresponding instrument settings. The contents of the 80 characters read does not correspond to the original data contents of the 8566A/8568A family.
RB	Default value, range, step size
RL	Default value, step size

Command	Known Differences
RLPOS	Adapts the position of the reference level even if the tracking generator normalization is not active.
RQS	Supported bits: 1 (Units key pressed) 2 (End of Sweep) 3 (Device error) 4 (Command complete) 5 (Illegal command)

### 13.12.4 Model-Dependent Default Settings

If the GPIB language is switched over to an 85xx model, the GPIB address is automatically switched over to 18 provided that the default address of the R&S ESW (20) is still set. If a different value is set, this value is maintained. Upon return to SCPI, this address remains unchanged.

The following table shows the default settings obtained after a change of the GPIB language and for the commands IP, KST and RESET:

Model	# of Trace Points	Start Freq.	Stop Freq.	Ref Level	Input Coupling
8566A/B	1001	2 GHz	22 GHz	0 dBm	AC
8568A/B	1001	0 Hz	1.5 GHz	0 dBm	AC
8560E	601	0 Hz	2.9 GHz	0 dBm	AC
8561E	601	0 Hz	6.5 GHz	0 dBm	AC
8562E	601	0 Hz	13.2 GHz	0 dBm	AC
8563E	601	0 Hz	26.5 GHz	0 dBm	AC
8564E	601	0 Hz	40 GHz	0 dBm	AC
8565E	601	0 Hz	50 GHz	0 dBm	AC
8594E	401	0 Hz	3 GHz	0 dBm	AC



#### Stop frequency

The stop frequency given in the table may be limited to the corresponding frequency range of the R&S ESW.

Command LF sets the stop frequency for 8566A/B to a maximum value of 2 GHz.

#### Test points (trace points)

The number of trace points is switched over only upon transition to the REMOTE state.

### 13.12.5 Data Output Formats

In the case of the SCPI and IEEE488.2 standards, the output formats for numerical data are flexible to a large extent. The output format for the HP units, by contrast, is accurately defined with respect to the number of digits. The memory areas for reading instrument data have therefore been adapted accordingly in the remote-control programs for instruments of this series.

Therefore, in response to a query, the R&S ESW returns data of the same structure as that used by the original instruments; this applies in particular to the number of characters returned.

Two formats are currently supported when trace data is output: Display Units (command O1) and physical values (command O2, O3 or TDF P). As to the "Display Units" format, the level data of the R&S ESW is converted to match the value range and the resolution of the 8566/8568 series. Upon transition to the **REMOTE** state, the R&S ESW is reconfigured such that the number of test points (trace points) corresponds to that of the 85xx families (1001 for 8566A/B and 8568A/B, 601 for 8560E to 8565E, 401 for 8594E).

### 13.12.6 Trace Data Output Formats

All formats are supported for trace data output: display units (command O1), display units in two byte binary data (command O2 or TDF B and MDS W), display units in one byte binary data (command O4 or TDF B and MDS B) and physical values (commands O3 or TDF P). With format "display units" the level data is converted into value range and resolution of the 8566/8568 models. On transition to REMOTE state the number of trace points are reconfigured in order to be conform to the selected instrument model (1001 for 8566A/B and 8568 A/B, 601 for 8560E to 8565E, 401 for 8594E).

### 13.12.7 Trace Data Input Formats

Trace data input is only supported for binary date (TDF B, TDF A, TDF I, MDS W, MDS B).

### 13.12.8 GPIB Status Reporting

The assignment of status bits by commands R1, R2, R3, R4, RQS is supported.

The STB command and the serial poll respond with an 8-bit value with the following assignment:

Bit enabled by RQS	Description
0	not used (value 0)
1	Units key pressed
2	End of Sweep

Bit enabled by RQS	Description
3	Device Error
4	Command Complete
5	Illegal Command
6	Service Request
7	not used (value 0)

Bits 0 and 7 are not used and always have the value 0.

Please note that the R&S ESW reports any key pressed on the front panel rather than only the unit keys if bit 1 was enabled.

Another difference is the behavior of bit 6 when using the STB? query. On the HP analyzers this bit monitors the state of the SRQ line on the bus. On the R&S ESW this is not possible. Therefore this bit is set, as soon as one of the bits 1 to 5 is set. It won't be reset by performing a serial poll.

### 13.13 Reference: Command Set of Emulated PSA Models

Despite the differences in system architecture and device features, the supported commands have been implemented in a way to ensure a sufficiently high degree of correspondence with the original.

In many cases the selection of commands supported by the R&S ESW is sufficient to run an existing GPIB program without adaptation.

Supported 89600 commands
*CAL?
*CLS
*ESE
*ESR?
*IDN?
*IST?
*OPC
*OPT?
*PCB
*PRE
*PSC
*RST
*SRE

Supported 89600 commands
*STB?
*TRG
*TST?
*WAI
:CALibration:AUTO OFF ON ALERT
:CALibration:TCORrections AUTO ON OFF
:CONFigure:WAVeform
:DIAGnostic:EABY ON OFF
:DIAGnostic:LATCh:VALue <numeric>
:DIAGnostic:LATCh:SElect <string>
:DISPlay:ANNotation:TITLe:DATA <string>
:DISPlay:ENABle OFF ON
:DISPlay:WINDow:TRACe:Y:[SCALE]:PDIVision <numeric>
:DISPlay:WINDow:TRACe:Y:[SCALE]:RLEVel <numeric>
:DISPlay:WINDow:TRACe:Y:[SCALE]:RLEVel:OFFSet <numeric>
:FORMat:BORDER NORMAl SWAPped
:FORMat[:DATA] ASCii REAL UINT MATLAB,<numeric>
:INITiate:CONTInuous OFF ON
:INITiate[:IMMediate]
:INSTrument:CATalog?
:INSTrument:NSElect <numeric>
:MMEMory:CATalog? <dir_name>
:MMEMory:COPY <'file_name1'>,<'file_name2'>
:MMEMory:DATA <'file_name'>,<definite_length_block>
:MMEMory:DELeTe <'file_name'>
:MMEMory:LOAD:STATe 1,<'file_name'>
:MMEMory:LOAD:TRACe 1,<'file_name'>
:MMEMory:MDIRectory <'dir_name'>
:MMEMory:MOVE <'file_name1'>,<'file_name2'>
:MMEMory:STORe:STATe 1,<'file_name'>
:MMEMory:STORe:TRACe <numeric>,<'file_name'>
:READ:WAVform?
[:SENSe]:FREQuency:CENTer <numeric>



Supported 89600 commands
[.SENSe]:FREQuency:STARt <numeric>
[.SENSe]:FREQuency:STOP <numeric>
[.SENSe]:FREQuency:SPAN <numeric>
[.SENSe]:POWer:ATTenuation <numeric>
[.SENSe]:ROSCillator:EXTernal:FREQuency <numeric>
[.SENSe]:ROSCillator:OUTPut OFF ON
[.SENSe]:ROSCillator:SOURce INTernal EXTernal EAUto
[.SENSe]:SPECtrum:TRIGger:SOURce EXTernal<1 2> IF IMMediate
[.SENSe]:WAVeform:ADC:RANGe P6
[.SENSe]:WAVeform:APER?
[.SENSe]:WAVeform:AVERage:TACount <numeric>
[.SENSe]:WAVeform:BWIDth:ACTive?
[.SENSe]:WAVeform:BWIDth:TYPE FLAT GAUSSian
[.SENSe]:WAVeform:IFGain <numeric>
[.SENSe]:WAVeform:IFPath NARRow WIDE
[.SENSe]:WAVeform:NCPTTrace ON OFF
[.SENSe]:WAVeform:PDIT ON OFF
[.SENSe]:WAVeform:SRATe <numeric>
[.SENSe]:WAVeform:SWEep:TIME <numeric>
[.SENSe]:WAVeform:TRIGger:EOFFset?
[.SENSe]:WAVeform:TRIGger:INTerpolation ON OFF
[.SENSe]:WAVeform:TRIGger:SOURce EXTernal<1 2> IF IMMediate
:STATus:QUEStionable:CONDition?
:STATus:QUEStionable:ENABLE <number>
:STATus:QUEStionable:NTRansition <number>
:STATus:QUEStionable:PTRansition <number>
:STATus:QUEStionable[:EVENT]?
:STATus:QUEStionable:CALibration:CONDition?
:STATus:QUEStionable:CALibration:ENABLE <number>
:STATus:QUEStionable:CALibration:NTRansition <number>
:STATus:QUEStionable:CALibration:PTRansition <number>
:STATus:QUEStionable:CALibration[:EVENT]?
:STATus:QUEStionable:FREQuency:CONDition?

Supported 89600 commands
:STATus:QUESTionable:FREQuency:ENABle <number>
:STATus:QUESTionable:FREQuency:NTRansition <number>
:STATus:QUESTionable:FREQuency:PTRansition <number>
:STATus:QUESTionable:FREQuency[:EVENT]?
:STATus:QUESTionable:INTegrity:CONDition?
:STATus:QUESTionable:INTegrity:ENABle <number>
:STATus:QUESTionable:INTegrity:NTRansition <number>
:STATus:QUESTionable:INTegrity:PTRansition <number>
:STATus:QUESTionable:INTegrity[:EVENT]?
:STATus:OPERation:CONDition?
:STATus:OPERation:ENABle <integer>
:STATus:OPERation:NTRansition <integer>
:STATus:OPERation:PTRansition <integer>
:STATus:OPERation[:EVENT]?
:SYSTem:COMMunicate:GPIB[:SELF]:ADDRess <integer>
:SYSTem:DATE <year>,<month>,<day>
:SYSTem:ERRor[:NEXT]?
:SYSTem:KLOCK?
:SYSTem:MESSage <string>
:SYSTem:PRESet
:SYSTem:TIME <hour>,<minute>,<second>
:SYSTem:VERSion?
:TRACe:COPY <src_trace>,<dest_trace>
:TRACe[:DATA] TRACE1   TRACE2   TRACE3   TRACE4   TRACE5   TRACE6, <definite_length_block>   <comma_separated_ASCII_data>
:TRACe:MODE WRITe MAXHold MINHold VIEW BLANK
:TRIGger[:SEQuence]:DELay <numeric>
:TRIGger[:SEQuence]:DELay:STATe OFF ON 0 1
:TRIGger[:SEQuence]:EXTerMal:DELay <numeric>
:TRIGger[:SEQuence]:EXTerMal:LEVel <numeric>
:TRIGger[:SEQuence]:EXTerMal:SLOPe POSitive NEGative
:TRIGger[:SEQuence]:HOLDoff <numeric>
:TRIGger[:SEQuence]:IF:DELay <numeric>
:TRIGger[:SEQuence]:IF:LEVel <numeric>

<b>Supported 89600 commands</b>
:TRIGger[:SEQuence]:IF:SLOPe POSitive NEGative
:TRIGger[:SEQuence]:SLOPe POSitive NEGative
:TRIGger[:SEQuence]:SOURce IMMEDIATE VIDeo EXTernal<1 2>
:TRIGger[:SEQuence]:VIDeo:LEVel <numeric>
:TRIGger[:SEQuence]:VIDeo:LEVel:FREQuency <freq>

## 13.14 Reference: Command Set of Emulated PXA Models

The R&S ESW analyzer family supports a subset of the GPIB commands of PXA instruments.

Despite the differences in system architecture and device features, the supported commands have been implemented in a way to ensure a sufficiently high degree of correspondence with the original.

In many cases the selection of commands supported by the R&S ESW is sufficient to run an existing GPIB program without adaptation.

**Table 13-12: Supported PXA commands**

ABORT
CALCulate:MARKer:AOFF
CALCulate:MARKer[1] 2 ...12:MAXimum
CALCulate:MARKer[1] 2 ...12:MAXimum:LEFT
CALCulate:MARKer[1] 2 ...12:MAXimum:NEXT
CALCulate:MARKer[1] 2 ...12:MAXimum:RIGHT
CALCulate:MARKer[1] 2 ...12:MINimum
CALCulate:MARKer[1] 2 ...12:MODE POSition   DELTa   FIXed   OFF
CALCulate:MARKer[1] 2 ...12:MODE[?] SPAN   BAND
CALCulate:MARKer[1] 2 ...12[:SET]:CENTer
CALCulate:MARKer[1] 2 ...12[:SET]:RLEVel
CALCulate:MARKer[1] 2 ...12[:SET]:START
CALCulate:MARKer[1] 2 ...12[:SET]:STOP
CALCulate:MARKer[1] 2 ...12:STATe[?] OFF   ON   0   1
CALCulate:MARKer[1] 2 ...12:X[?] <freq   time>
CALCulate:MARKer[1] 2 ...12:X:POSition[?] <real>
CALCulate:MARKer[1] 2 ...4:X:SPAN
CALCulate:MARKer[1] 2 ...4:X:START

CALCulate:MARKer[1][2]...4:X:STOP
CALCulate:MARKer[1][2]...12:Y[?] <real>
CALibration[:ALL][?]
CALibration:AUTO[?] ON   PARTial   OFF   ALERT
CALibration:AUTO:ALERT[?] TTEMPerature   DAY   WEEK   NONE
CALibration:AUTO:MODE[?] ALL   NRF
CALibration:AUTO:TIME:OFF?
CONFigure? SAN
DISPlay:WINDow[1]:TRACe:Y[:SCALe]:RLEVel[?] <real>
DISPlay:WINDow[1]:TRACe:Y[:SCALe]:RLEVel:OFFSet[?] <rel_amp>
INITiate:CONTinuous[?] OFF   ON   0   1
INITiate[:IMMediate]
INPut:COUPling[?] AC   DC
MMEMory:CATalog? [<directory_name>]
MMEMory:CDIRectory[?] [<directory_name>]
MMEMory:COpy <string>, <string>[, <string>, <string>]
MMEMory:DATA[?] <file_name>, <data>
MMEMory:DElete <file_name>[, <directory_name>]
MMEMory:LOAD:STATe 1, <filename>
MMEMory:MDIRectory <directory_name>
MMEMory:MOVe <string>, <string>[, <string>, <string>]
MMEMory:RDIRectory <directory_name>
MMEMory:STORe:STATe 1, <filename>
[:SENSe]:AVERAge:COUNT[?] <integer>
[:SENSe]:AVERAge[:STATe][?] ON   OFF   1   0
[:SENSe]:AVERAge:TYPE[?] RMS   LOG   SCALar[:SENSe]:AVERAge:TYPE?
[:SENSe]:BANDwidth BWIDth[:RESolution][?] <freq>
[:SENSe]:BANDwidth BWIDth[:RESolution]:AUTO[?] OFF   ON   0   1
[:SENSe]:BANDwidth BWIDth:VIDeo[?] <freq>
[:SENSe]:BANDwidth BWIDth:VIDeo:AUTO[?] OFF   ON   0   1
[:SENSe]:BANDwidth BWIDth:VIDeo:RATio[?] <real>
[:SENSe]:BANDwidth BWIDth:VIDeo:RATio:AUTO[?] OFF   ON   0   1
[:SENSe]:DETEctor:AUTO[?] ON   OFF   1   0
[:SENSe]:FREQuency:CENTer[?] <freq>

[.SENSe]:FREQUency:CENTer:STEP:AUTO[?] OFF   ON   0   1
[.SENSe]:FREQUency:OFFSet[?] <freq>
[.SENSe]:FREQUency:SPAN[?] <freq>
[.SENSe]:FREQUency:SPAN:FULL
[.SENSe]:FREQUency:START[?] <freq>
[.SENSe]:FREQUency:STOP[?] <freq>
[.SENSe]:POWer[:RF]:ATTenuation[?] <rel_ampl>
[.SENSe]:POWer[:RF]:ATTenuation:AUTO[?] OFF   ON   0   1
[.SENSe]:SWEep:POINts? <integer>
[.SENSe]:SWEep:TIME? <time>
[.SENSe]:SWEep:TIME:AUTO? OFF   ON   0   1
TRIGger[:SEQUence]:EXTernal2:DELay[?] <time>
TRIGger[:SEQUence]:EXTernal1:DELay[?] <time>
TRIGger[:SEQUence]:EXTernal2:DELay:STATe[?] OFF   ON   0   1
TRIGger[:SEQUence]:EXTernal1:DELay:STATe[?] OFF   ON   0   1
TRIGger[:SEQUence]:EXTernal2:LEVel[?] <level>
TRIGger[:SEQUence]:EXTernal1:LEVel[?] <level>
TRIGger[:SEQUence]:EXTernal2:SLOPe[?] POSitive   NEGative
TRIGger[:SEQUence]:EXTernal1:SLOPe[?] POSitive   NEGative
TRIGger[:SEQUence]:IF:LEVel[?]
TRIGger[:SEQUence]:IF:SLOPe[?] NEGative   POSitive
TRIGger[:SEQUence]:SOURCe EXTernal   IMMEDIATE   VIDEO   LINE   EXTernal1   EXT1   EXTernal2   EXT2   RFBurst   FRAME
TRIGger[:SEQUence]:VIDeo:DELay[?] <time>
TRIGger[:SEQUence]:VIDeo:DELay:STATe[?] OFF   ON   0   1
TRIGger[:SEQUence]:VIDeo:LEVel[?] <ampl>
TRIGger[:SEQUence]:VIDeo:SLOPe[?] POSitive   NEGative

## 14 Maintenance

The R&S ESW does not require regular maintenance. Maintenance is essentially restricted to cleaning the R&S ESW. It is, however, recommended that you check the nominal data from time to time.

The data sheet specifies the storage temperature range for the R&S ESW. Protect the instrument against dust if it is to be stored for a long period.

### 14.1 Cleaning

---

**⚠ WARNING****Risk of electric shock**

If moisture enters the casing, for example if you clean the instrument using a moist cloth, contact with the instrument can lead to electric shock. Before cleaning the instrument other than with a dry cloth, make sure that the instrument is switched off and disconnected from all power supplies.

---

**NOTICE****Instrument damage caused by cleaning agents**

Cleaning agents contain substances such as solvents (thinners, acetone, etc.), acids, bases, or other substances. Solvents can damage the front panel labeling, plastic parts, or screens, for example.

Never use cleaning agents to clean the outside of the instrument. Use a soft, dry, lint-free dust cloth instead.

---

**NOTICE****Risk of instrument damage due to obstructed fans**

If the instrument is operated in dusty areas, the fans become obstructed by dust or other particles over time. Check and clean the fans regularly to ensure that they always operate properly. If the instrument is run with obstructed fans for a longer period, the instrument overheats, which can disturb the operation and even cause damage.

---

1. Clean the outside of the instrument using a soft, dry, lint-free dust cloth.
2. Check and clean the fans regularly to ensure that they always operate properly.
3. Clean the touchscreen as follows:
  - a) Apply a small amount of standard screen cleaner to a soft cloth.
  - b) Wipe the screen gently with the moist, but not wet, cloth.

- c) If necessary, remove any excess moisture with a dry, soft cloth.

# 15 Troubleshooting

If the results do not meet your expectations, the following sections may contain helpful hints and information.

- [Error Information](#)..... 713
- [Error Messages in Remote Control Mode](#)..... 714
- [Troubleshooting Remote Operation](#)..... 715
- [Miscellaneous Troubleshooting Hints](#)..... 717
- [Collecting Information for Technical Support](#)..... 718

## 15.1 Error Information

If errors or irregularities are detected, a keyword and an error message, if available, are displayed in the status bar.



Depending on the type of message, the status message is indicated in varying colors.

**Table 15-1: Status bar information - color coding**

Color	Type	Description
Red	Error	An error occurred at the start or during a measurement, e.g. due to missing data or wrong settings, so that the measurement cannot be started or completed correctly.
Orange	Warning	An irregular situation occurred during measurement, e.g. the settings no longer match the displayed results, or the connection to an external device was interrupted temporarily.
Gray	Information	Information on the status of individual processing steps.
No color	No errors	No message displayed - normal operation.
Green	Measurement successful	Some applications visualize that the measurement was successful by showing a message.



If any error information is available for a channel, an exclamation mark is displayed next to the channel name (⚠). This is particularly useful when the MultiView tab is displayed, as the status bar in the MultiView tab always displays the information for the currently selected measurement only.

Furthermore, a status bit is set in the `STATUS:QUESTIONABLE:EXTENDED:INFO` register for the application concerned. Messages of a specific type can be queried using the `SYSTEM:ERROR:EXTENDED?` command. For more information, see the R&S ESW User Manual.

When you select the error message bar or status message bar, the R&S ESW shows a list of all current errors or status messages. In the error message bar, you can select one of the error messages to open a dialog box that can help you to remedy the error.



Refer to the table below for information about which error message opens which dialog box.

**Table 15-2: List of keywords**

<b>AC COUP</b>	<p>This label is displayed when a measurement is configured to be AC coupled, but information in the DC range is detected. This situation can yield inaccurate measurement results.</p> <p>You can avoid this error message by changing the input coupling type.</p> <p>Selecting the "AC Coup" error message opens a dialog box to configure the RF input.</p>
<b>IF OVLD</b>	<p>Overload of the IF signal path in the A/D converter or in the digital IF.</p> <ul style="list-style-type: none"> <li>• Increase the reference level.</li> </ul> <p>Selecting the "IF OVLD" error message opens a dialog box to configure the amplitude.</p>
<b>INPUT OVLD</b>	<p>The signal level at the RF input connector exceeds the maximum.</p> <p>The RF input is disconnected from the input mixer to protect the device. To re-enable measurement, decrease the level at the RF input connector and reconnect the RF input to the mixer input.</p> <p>Selecting the "Input OVLD" error message opens a dialog box to configure the amplitude.</p>
<b>LOUNL</b>	<p>Error in the instrument's frequency processing hardware was detected.</p>
<b>NO REF</b>	<p>Instrument was set to an external reference but no signal was detected on the reference input.</p> <p>Selecting the "No Ref" error message opens a dialog box to configure the external reference.</p>
<b>OVEN</b>	<p>The optional OCXO reference frequency has not yet reached its operating temperature. The message usually disappears a few minutes after power has been switched on.</p>
<b>RF OVLD</b>	<p>Overload of the input mixer or of the analog IF path.</p> <ul style="list-style-type: none"> <li>• Increase the RF attenuation (for RF input).</li> <li>• Reduce the input level (for digital input)</li> </ul> <p>Selecting the "RF OVLD" error message opens a dialog box to configure the amplitude.</p>
<b>UNCAL</b>	<p>One of the following conditions applies:</p> <ul style="list-style-type: none"> <li>• Correction data has been switched off.</li> <li>• No correction values are available, for example after a firmware update.</li> <li>• Record the correction data by performing a self alignment</li> </ul> <p>Selecting the "Uncal" error message opens the "Self Alignment dialog box."</p>
<b>WRONG_FW</b>	<p>The firmware version is out-of-date and does not support the currently installed hardware. Until the firmware version is updated, this error message is displayed and self-alignment fails.</p> <p>Selecting the "Wrong_FW" error message opens a dialog box to manage firmware and options.</p>

## 15.2 Error Messages in Remote Control Mode

In remote control mode error messages are entered in the error/event queue of the status reporting system and can be queried with the command `SYSTEM:ERROR?`. The answer format of R&S ESW to the command is as follows:

<error code>, "<error text with queue query>; <remote control command concerned>"

The indication of the remote control command with prefixed semicolon is optional.

#### Example:

The command `TEST:COMMAND` generates the following answer to the query `SYSTem:ERRor?`

```
-113,"Undefined header;TEST:COMMAND"
```

There are two types of error messages:

- Error messages defined by SCPI are marked by negative error codes. These messages are defined and described in the SCPI standard and not listed here.
- Device-specific error messages use positive error codes. These messages are described below.

**Table 15-3: Device-specific error messages**

Error code	Error text in the case of queue poll Error explanation
1052	<b>Frontend LO is Unlocked</b> This message is displayed when the phase regulation of the local oscillator fails in the RF front-end.
1060	<b>Trigger-Block Gate Delay Error- gate length &lt; Gate Delay</b> This message is displayed when the gate signal length is not sufficient for the pull-in delay with a predefined gate delay.
1064	<b>Tracking LO is Unlocked</b> This message is displayed when the phase regulation of the local oscillator fails on the external generator module.
2028	<b>Hardcopy not possible during measurement sequence</b> This message is displayed when a printout is started during scan sequences that cannot be interrupted. Such sequences are for example: <ul style="list-style-type: none"> <li>• Recording the system error correction data (alignment)</li> <li>• Instrument self-test</li> </ul> In such cases synchronization to the end of the scan sequence should be performed prior to starting the printout.
2033	<b>Printer Not Available</b> This message is displayed when the selected printer is not included in the list of available output devices. A possible cause is that the required printer driver is missing or incorrectly installed.
2034	<b>CPU Temperature is too high</b> This message is displayed when the temperature of the processor exceeds 70 °C.

## 15.3 Troubleshooting Remote Operation

If problems arise during measurement in remote operation, try the following methods to solve them.

### Incompleted sequential commands - blocked remote channels

If a sequential command cannot be completed, for example because a triggered sweep never receives a trigger, the remote control program will never finish and the remote channel to the R&S ESW is blocked for further commands. In this case, you must interrupt processing on the remote channel in order to abort the measurement.

### To regain control over a blocked remote channel

Usually, if you wait a minute for the VISA connection to detect the lost connection and clear the control channel by itself, you can then re-establish the connection again. If this fails, try the following:

1. Press "Local" on the front panel of the R&S ESW to return to manual operation (if not disabled). Then re-establish the connection.
2. Send a "Device Clear" command from the control instrument to the R&S ESW to clear all currently active remote channels. Depending on the used interface and protocol, send the following commands:

- **Visa:** `viClear()`
- **GPIB:** `ibclr()`
- **RSIB:** `RSDLLibclr()`

The remote channel currently processing the incompleted command is then ready to receive further commands again.

3. On the remote channel performing the measurement, send the SCPI command `ABORT` to abort the current measurement and reset the trigger system.
4. If the R&S ESW still does not react to the remote commands, switch it off and back on.

### Ignored commands

When a remote command attempts to define incompatible settings, the command is ignored and the instrument status remains unchanged, i.e. other settings are not automatically adapted. Therefore, control programs should always define an initial instrument status (e.g. using the `*RST` command) and then implement the required settings.

### Detecting false commands

If a remote program does not provide the expected results and you are using a GPIB connection, you can log the commands and any errors that may occur. To activate the SCPI error log function, in the "Network + Remote" dialog box, in the "GPIB" tab, select "I/O Logging".

All remote control commands received by the R&S ESW are recorded in the following log file:

```
C:\Program Files
(x86)\Rohde-Schwarz\ESW\\ScpiLogging\ScpiLog.txt
```

Logging the commands may be extremely useful for debug purposes, e.g. in order to find misspelled keywords in control programs. However, remember to turn off the log-

ging function after debugging to avoid unnecessary access to the hard drive and use of storage space.

## 15.4 Miscellaneous Troubleshooting Hints

Power levels for low frequency signals not correct.....	717
Invalid trace display.....	717
Data capturing takes too long.....	717
Multiple user access to one instrument.....	717
Web browser access to instrument fails .....	718
The transducer factors/limit lines applied to my measurement are different to those displayed in the Transducer/Lines dialog box.....	718

### Power levels for low frequency signals not correct

By default, the R&S ESW uses AC coupling for RF input. For very low frequencies, the input signal may be distorted with this setting. In this case, use DC coupling instead. To change the setting, select "INPUT/OUPUT" > "Input Source Config > Radio Frequency > Input Coupling > DC".

### Invalid trace display

If output to the "IF 2 GHz OUT" connector is activated, the measured values are no longer sent to the display; thus, the trace data currently displayed on the R&S ESW becomes invalid. A message in the status bar indicates this situation.

### Data capturing takes too long Spectrum application only.

Particularly for FFT sweeps, the time required to process the data may be considerably longer than the time required to capture the data. Thus, if you only consider the defined sweep time, you may assume an error has occurred if the measurement takes longer than expected.

However, while the sweep time only defines the time in which data is actually captured, the total sweep *duration* includes the time required for capturing *and processing* the data. Thus, for FFT sweeps in the Spectrum application, the sweep duration is now also indicated in the channel bar, behind the sweep time. In remote operation, the estimated sweep duration can be queried for all sweep modes (also zero span and frequency sweeps).

**Tip:** To determine the necessary timeout for data capturing in a remote control program, double the estimated time and add 1 second.

Remote command:

```
[SENSe:]SWEep:DURation
```

### Multiple user access to one instrument

Using the R&S ESW's LXI browser interface, several users can access *and operate* the same instrument simultaneously. This is useful for troubleshooting or training purposes.

Type the instrument's host name or IP address in the address field of the browser on your PC, for example "http://10.113.10.203". The instrument home page (welcome page) opens.

**Note:** This function can be deactivated for the instrument. After a firmware update, it is automatically activated again.

#### **Web browser access to instrument fails**

If an error message ("Failed to connect to server (code. 1006)") is displayed in the web browser instead of the instrument's user interface then the LXI web browser interface was probably deactivated.

#### **The transducer factors/limit lines applied to my measurement are different to those displayed in the Transducer/Lines dialog box**

If a transducer file was in use when the save set was stored (with the save item "Current Settings" only) it is anticipated that these transducer values should remain valid after every recall of that save set. Thus, even if the transducer file is changed and the original save set file is recalled later, the *originally stored* transducer values are recalled and applied to the measurement. In the "Transducer" dialog box, however, the *changed* transducer file values are displayed as no updated transducer file was loaded.

The same applies to limit line settings.

If you want to apply the changed transducer values after recalling the save set you must force the application to reload the transducer file. To do so, simply open the "Edit Transducer" dialog box (see [Chapter 11.3.2, "Working with Transducers"](#), on page 307) and toggle the "X-Axis" option from "lin" to "log" and back. Due to that change, the transducer file is automatically reloaded, and the changed transducer values are applied to the current measurement. Now you can create a new save set with the updated transducer values.

Similarly, if you want to apply the changed limit values after recalling the save set you must force the application to reload the limit file. To do so, simply open the "Edit Limit Line" dialog box (see [Chapter 9.5.2.2, "Limit Line Settings and Functions"](#), on page 237) and toggle the "Y-Axis" unit. Due to that change, the limit line file is automatically reloaded, and the changed limit values are applied to the current measurement. Now a new save set with the updated limit values can be created.

## 15.5 Collecting Information for Technical Support

If problems occur, the instrument generates error messages which in most cases will be sufficient for you to detect the cause of an error and find a remedy.

In addition, our customer support centers are there to assist you in solving any problems that you may encounter with your R&S ESW. We will find solutions more quickly and efficiently if you provide us with the information listed below.

- **System Configuration:** The "System Configuration" dialog box (in the "Setup" menu) provides information on:
  - **Hardware Info:** hardware assemblies

- **Versions and Options:** the status of all software and hardware options installed on your instrument
- **System Messages:** messages on any errors that may have occurred

An .xml file with information on the system configuration ( "Device Footprint" ) can be created automatically (using the `DIAGnostic:SERvice:SINFo` command or as described in "To collect the support information" on page 80).

- **Error Log:** The `RSError.log` file (in the `C:\Program Files (x86)\Rohde-Schwarz\ESW\<version>\log` directory) contains a chronological record of errors.
- **Support file:** a \*.zip file with important support information can be created automatically (in the `C:\Program Files (x86)\Rohde-Schwarz\ESW\<version>\user` directory). The \*.zip file contains the system configuration information ( "Device Footprint" ), the current eeprom data and a screenshot of the screen display.

### To collect the support information

1. Press the [SETUP] key.
2. Select "Service" > "R&S Support" and then "Create R&S Support Information" .

The file is stored as

```
C:\Program Files (x86)\Rohde-Schwarz\ESW\<version>\user\  
<inst_model>_<serial-no>_<date_and_time>.zip
```

The file is stored as

```
C:\Program Files (x86)\Rohde-Schwarz\ESW\<version>\user\  
ESW_*.zip.
```

Collect the error information and attach it to an email in which you describe the problem. Send the email to the customer support address for your region as listed on the Internet (<http://www.customersupport.rohde-schwarz.com>).



### Packing and transporting the instrument

If the instrument needs to be transported or shipped, observe the notes described in [Chapter 2.1.1, "Unpacking and Checking the Instrument"](#), on page 20.

---

## List of Commands

[SENSe:]BANDwidth:IF.....	498
[SENSe:]BANDwidth:SCPL.....	498
[SENSe:]BANDwidth[:RESolution]:AUTO.....	499
[SENSe:]BANDwidth[:RESolution]:TYPE.....	499
[SENSe:]BANDwidth[:RESolution][:VALue].....	498
[SENSe:]BWIDth:IF.....	498
[SENSe:]BWIDth:SCPL.....	498
[SENSe:]BWIDth[:RESolution].....	498
[SENSe:]BWIDth[:RESolution]:AUTO.....	499
[SENSe:]BWIDth[:RESolution]:TYPE.....	499
[SENSe:]CORRection:SWITch:ADDReSS.....	620
[SENSe:]CORRection:SWITch:COMMeNt.....	620
[SENSe:]CORRection:SWITch:DEFault:EXECute.....	621
[SENSe:]CORRection:SWITch:DEFault[:COMMaNd].....	620
[SENSe:]CORRection:SWITch:DELeTe.....	621
[SENSe:]CORRection:SWITch:INPut.....	621
[SENSe:]CORRection:SWITch:LOAD.....	621
[SENSe:]CORRection:SWITch:NAME.....	622
[SENSe:]CORRection:SWITch:OPC.....	622
[SENSe:]CORRection:SWITch:RANGe<range>:EXECute.....	623
[SENSe:]CORRection:SWITch:RANGe<range>[:COMMaNd].....	622
[SENSe:]CORRection:SWITch:SCPI.....	623
[SENSe:]CORRection:SWITch:SELeCt.....	623
[SENSe:]CORRection:SWITch:STORe.....	623
[SENSe:]CORRection:SWITch:WAIT.....	624
[SENSe:]CORRection:TRANSDucer:ACTive?.....	624
[SENSe:]CORRection:TRANSDucer:ADJust:RLEVel[:STATe].....	624
[SENSe:]CORRection:TRANSDucer:CATalog?.....	624
[SENSe:]CORRection:TRANSDucer:COMMeNt.....	625
[SENSe:]CORRection:TRANSDucer:DATA.....	625
[SENSe:]CORRection:TRANSDucer:DELeTe.....	626
[SENSe:]CORRection:TRANSDucer:INPut<rf>:ACTive?.....	624
[SENSe:]CORRection:TRANSDucer:INPut<rf>[:STATe].....	626
[SENSe:]CORRection:TRANSDucer:SCALing.....	626
[SENSe:]CORRection:TRANSDucer:SELeCt.....	626
[SENSe:]CORRection:TRANSDucer:UNIT.....	626
[SENSe:]CORRection:TRANSDucer:VIEW.....	460
[SENSe:]CORRection:TRANSDucer[:STATe].....	626
[SENSe:]CORRection:TSET:BReAk.....	627
[SENSe:]CORRection:TSET:CATalog?.....	627
[SENSe:]CORRection:TSET:COMMeNt.....	628
[SENSe:]CORRection:TSET:DELeTe.....	628
[SENSe:]CORRection:TSET:INPut<rf>[:STATe].....	629
[SENSe:]CORRection:TSET:RANGe<range>.....	628
[SENSe:]CORRection:TSET:SELeCt.....	629
[SENSe:]CORRection:TSET:UNIT.....	629
[SENSe:]CORRection:TSET[:STATe].....	629

[SENSe:]DEMod:SQUelch:LEVel.....	487
[SENSe:]DEMod:SQUelch[::STATe].....	487
[SENSe:]DETEctor<t>:FMEasurement.....	461
[SENSe:]DETEctor<t>:RECeiver[:FUNction].....	439
[SENSe:]DETEctor<t>[::FUNction].....	442
[SENSe:]FMEasurement:AUTO.....	462
[SENSe:]FMEasurement:LISN:PHASe.....	468
[SENSe:]FMEasurement:TIME.....	462
[SENSe:]FREQUency:CENTer.....	493
[SENSe:]FREQUency:CENTer:STEP.....	493
[SENSe:]FREQUency:MODE.....	440
[SENSe:]FREQUency:SPAN.....	493
[SENSe:]FREQUency:START.....	443
[SENSe:]FREQUency:STOP.....	443
[SENSe:]FREQUency:TDOPTim.....	441
[SENSe:]ROSCillator:LBWidth.....	611
[SENSe:]ROSCillator:O100.....	611
[SENSe:]ROSCillator:O640.....	612
[SENSe:]ROSCillator:OSYNc.....	612
[SENSe:]ROSCillator:SOURce.....	612
[SENSe:]ROSCillator:SOURce:EAUTO?.....	613
[SENSe:]ROSCillator:TRANge.....	614
[SENSe:]SCAN<sr>:BANDwidth:RESolution.....	444
[SENSe:]SCAN<sr>:BARS.....	444
[SENSe:]SCAN<sr>:INPut:ATTenuation:AUTO.....	445
[SENSe:]SCAN<sr>:INPut:ATTenuation[::VALue].....	445
[SENSe:]SCAN<sr>:INPut:GAIN:AUTO.....	445
[SENSe:]SCAN<sr>:INPut:GAIN:LNA:AUTO.....	446
[SENSe:]SCAN<sr>:INPut:GAIN:LNA:STATe.....	446
[SENSe:]SCAN<sr>:INPut:GAIN[::STATe].....	446
[SENSe:]SCAN<sr>:INPut:TYPE.....	447
[SENSe:]SCAN<sr>:LISN:PHASe.....	468
[SENSe:]SCAN<sr>:NAME.....	447
[SENSe:]SCAN<sr>:RANGES[::COUNT].....	447
[SENSe:]SCAN<sr>:START.....	448
[SENSe:]SCAN<sr>:STEP.....	448
[SENSe:]SCAN<sr>:STOP.....	449
[SENSe:]SCAN<sr>:TDOMain.....	441
[SENSe:]SCAN<sr>:TIME.....	449
[SENSe:]SWEep:COUNT.....	449
[SENSe:]SWEep:EGATE:HOLDoff.....	500
[SENSe:]SWEep:EGATE:LENGth.....	500
[SENSe:]SWEep:EGATE:POLarity.....	500
[SENSe:]SWEep:EGATE:SOURce.....	500
[SENSe:]SWEep:EGATE:TYPE.....	501
[SENSe:]SWEep:EGATE[::STATe].....	501
[SENSe:]SWEep:SPACing.....	450
[SENSe:]SWEep:TIME.....	440
*CAL?.....	418
*CLS.....	418



*ESE.....	418
*ESR?.....	418
*IDN?.....	419
*IST?.....	419
*OPC.....	419
*OPT?.....	419
*PCB.....	419
*PRE.....	420
*PSC.....	420
*RST.....	420
*SRE.....	420
*STB?.....	421
*TRG.....	421
*TST?.....	421
*WAI.....	421
ABORT.....	426
CALCulate:STATistics:CAPD[:STATe].....	422
CALCulate<n>:DELTamarker<m>:AOFF.....	525
CALCulate<n>:DELTamarker<m>:MAXimum:LEFT.....	535
CALCulate<n>:DELTamarker<m>:MAXimum:NEXT.....	536
CALCulate<n>:DELTamarker<m>:MAXimum:RIGHT.....	536
CALCulate<n>:DELTamarker<m>:MAXimum[:PEAK].....	536
CALCulate<n>:DELTamarker<m>:MINimum:LEFT.....	537
CALCulate<n>:DELTamarker<m>:MINimum:NEXT.....	537
CALCulate<n>:DELTamarker<m>:MINimum:RIGHT.....	537
CALCulate<n>:DELTamarker<m>:MINimum[:PEAK].....	537
CALCulate<n>:DELTamarker<m>:MODE.....	525
CALCulate<n>:DELTamarker<m>:MREF.....	525
CALCulate<n>:DELTamarker<m>:SGRam:FRAME.....	545
CALCulate<n>:DELTamarker<m>:SGRam:SARea.....	545
CALCulate<n>:DELTamarker<m>:SGRam:XY:MAXimum[:PEAK].....	546
CALCulate<n>:DELTamarker<m>:SGRam:XY:MINimum[:PEAK].....	546
CALCulate<n>:DELTamarker<m>:SGRam:Y:MAXimum:ABOVE.....	546
CALCulate<n>:DELTamarker<m>:SGRam:Y:MAXimum:BELOW.....	546
CALCulate<n>:DELTamarker<m>:SGRam:Y:MAXimum:NEXT.....	547
CALCulate<n>:DELTamarker<m>:SGRam:Y:MAXimum[:PEAK].....	547
CALCulate<n>:DELTamarker<m>:SGRam:Y:MINimum:ABOVE.....	547
CALCulate<n>:DELTamarker<m>:SGRam:Y:MINimum:BELOW.....	548
CALCulate<n>:DELTamarker<m>:SGRam:Y:MINimum:NEXT.....	548
CALCulate<n>:DELTamarker<m>:SGRam:Y:MINimum[:PEAK].....	548
CALCulate<n>:DELTamarker<m>:SPECTrogram:FRAMe.....	545
CALCulate<n>:DELTamarker<m>:SPECTrogram:SARea.....	545
CALCulate<n>:DELTamarker<m>:SPECTrogram:XY:MAXimum[:PEAK].....	546
CALCulate<n>:DELTamarker<m>:SPECTrogram:XY:MINimum[:PEAK].....	546
CALCulate<n>:DELTamarker<m>:SPECTrogram:Y:MAXimum:ABOVE.....	546
CALCulate<n>:DELTamarker<m>:SPECTrogram:Y:MAXimum:BELOW.....	546
CALCulate<n>:DELTamarker<m>:SPECTrogram:Y:MAXimum:NEXT.....	547
CALCulate<n>:DELTamarker<m>:SPECTrogram:Y:MAXimum[:PEAK].....	547
CALCulate<n>:DELTamarker<m>:SPECTrogram:Y:MINimum:ABOVE.....	547
CALCulate<n>:DELTamarker<m>:SPECTrogram:Y:MINimum:BELOW.....	548

CALCulate<n>:DELTamarker<m>:SPECtrogram:Y:MINimum:NEXT.....	548
CALCulate<n>:DELTamarker<m>:SPECtrogram:Y:MINimum[:PEAK].....	548
CALCulate<n>:DELTamarker<m>:TRACe.....	526
CALCulate<n>:DELTamarker<m>:X.....	526
CALCulate<n>:DELTamarker<m>:X:RELative?.....	538
CALCulate<n>:DELTamarker<m>:Y?.....	538
CALCulate<n>:DELTamarker<m>[:STATe].....	526
CALCulate<n>:DLINe<dl>.....	549
CALCulate<n>:DLINe<dl>:STATe.....	549
CALCulate<n>:FLINe<fl>.....	549
CALCulate<n>:FLINe<fl>:STATe.....	550
CALCulate<n>:FMEasurement:PLISt<peak>:ALL?.....	464
CALCulate<n>:FMEasurement:PLISt<peak>:COMMENT.....	464
CALCulate<n>:FMEasurement:PLISt<peak>:DELTA?.....	465
CALCulate<n>:FMEasurement:PLISt<peak>:DETECTOR.....	465
CALCulate<n>:FMEasurement:PLISt<peak>:FREQUENCY?.....	466
CALCulate<n>:FMEasurement:PLISt<peak>:LEVEL?.....	466
CALCulate<n>:FMEasurement:PLISt<peak>:SIZE?.....	466
CALCulate<n>:FMEasurement:PLISt<peak>:TRACe?.....	467
CALCulate<n>:FMEasurement:PLISt<peak>[:DATA]?.....	467
CALCulate<n>:FMEasurement[:AUTO].....	460
CALCulate<n>:LIMit<li>:ACTive?.....	552
CALCulate<n>:LIMit<li>:CLEAR[:IMMEdiate].....	564
CALCulate<n>:LIMit<li>:COMMENT.....	557
CALCulate<n>:LIMit<li>:CONTRol:DOMain.....	557
CALCulate<n>:LIMit<li>:CONTRol:MODE.....	558
CALCulate<n>:LIMit<li>:CONTRol:OFFSet.....	552
CALCulate<n>:LIMit<li>:CONTRol:SHIFt.....	558
CALCulate<n>:LIMit<li>:CONTRol:SPACing.....	558
CALCulate<n>:LIMit<li>:CONTRol[:DATA].....	557
CALCulate<n>:LIMit<li>:COPY.....	552
CALCulate<n>:LIMit<li>:DELeTe.....	553
CALCulate<n>:LIMit<li>:FAIL?.....	564
CALCulate<n>:LIMit<li>:LOWer:MARGin.....	559
CALCulate<n>:LIMit<li>:LOWer:MODE.....	559
CALCulate<n>:LIMit<li>:LOWer:OFFSet.....	553
CALCulate<n>:LIMit<li>:LOWer:SHIFt.....	560
CALCulate<n>:LIMit<li>:LOWer:SPACing.....	560
CALCulate<n>:LIMit<li>:LOWer:STATe.....	553
CALCulate<n>:LIMit<li>:LOWer:THReshold.....	560
CALCulate<n>:LIMit<li>:LOWer[:DATA].....	559
CALCulate<n>:LIMit<li>:NAME.....	561
CALCulate<n>:LIMit<li>:STATe.....	554
CALCulate<n>:LIMit<li>:TRACe.....	554
CALCulate<n>:LIMit<li>:TRACe<t>:CHECK.....	554
CALCulate<n>:LIMit<li>:UNIT.....	561
CALCulate<n>:LIMit<li>:UPPer:MARGin.....	562
CALCulate<n>:LIMit<li>:UPPer:MODE.....	562
CALCulate<n>:LIMit<li>:UPPer:OFFSet.....	555
CALCulate<n>:LIMit<li>:UPPer:SHIFt.....	562

CALCulate<n>:LIMit<li>:UPPer:SPACing.....	563
CALCulate<n>:LIMit<li>:UPPer:STATe.....	555
CALCulate<n>:LIMit<li>:UPPer:THReshold.....	563
CALCulate<n>:LIMit<li>:UPPer[:DATA].....	561
CALCulate<n>:MARKer<m>:AOFF.....	527
CALCulate<n>:MARKer<m>:COUPled[:STATe].....	530
CALCulate<n>:MARKer<m>:FUNction:STRack:BANDwidth.....	491
CALCulate<n>:MARKer<m>:FUNction:STRack:THReshold.....	492
CALCulate<n>:MARKer<m>:FUNction:STRack:TRACe.....	492
CALCulate<n>:MARKer<m>:FUNction:STRack[:STATe].....	491
CALCulate<n>:MARKer<m>:MAXimum:LEFT.....	533
CALCulate<n>:MARKer<m>:MAXimum:NEXT.....	533
CALCulate<n>:MARKer<m>:MAXimum:RIGHT.....	534
CALCulate<n>:MARKer<m>:MAXimum[:PEAK].....	533
CALCulate<n>:MARKer<m>:MINimum:LEFT.....	534
CALCulate<n>:MARKer<m>:MINimum:NEXT.....	534
CALCulate<n>:MARKer<m>:MINimum:RIGHT.....	535
CALCulate<n>:MARKer<m>:MINimum[:PEAK].....	534
CALCulate<n>:MARKer<m>:PEXCursion.....	451
CALCulate<n>:MARKer<m>:SCOupled:LSCan.....	528
CALCulate<n>:MARKer<m>:SCOupled[:STATe].....	529
CALCulate<n>:MARKer<m>:SGRam:FRAME.....	540
CALCulate<n>:MARKer<m>:SGRam:SARea.....	541
CALCulate<n>:MARKer<m>:SGRam:XY:MAXimum[:PEAK].....	541
CALCulate<n>:MARKer<m>:SGRam:XY:MINimum[:PEAK].....	541
CALCulate<n>:MARKer<m>:SGRam:Y:MAXimum:ABOVE.....	542
CALCulate<n>:MARKer<m>:SGRam:Y:MAXimum:BELOW.....	542
CALCulate<n>:MARKer<m>:SGRam:Y:MAXimum:NEXT.....	542
CALCulate<n>:MARKer<m>:SGRam:Y:MAXimum[:PEAK].....	542
CALCulate<n>:MARKer<m>:SGRam:Y:MINimum:ABOVE.....	543
CALCulate<n>:MARKer<m>:SGRam:Y:MINimum:BELOW.....	543
CALCulate<n>:MARKer<m>:SGRam:Y:MINimum:NEXT.....	543
CALCulate<n>:MARKer<m>:SGRam:Y:MINimum[:PEAK].....	544
CALCulate<n>:MARKer<m>:SPECTrogram:FRAME.....	540
CALCulate<n>:MARKer<m>:SPECTrogram:SARea.....	541
CALCulate<n>:MARKer<m>:SPECTrogram:XY:MAXimum[:PEAK].....	541
CALCulate<n>:MARKer<m>:SPECTrogram:XY:MINimum[:PEAK].....	541
CALCulate<n>:MARKer<m>:SPECTrogram:Y:MAXimum:ABOVE.....	542
CALCulate<n>:MARKer<m>:SPECTrogram:Y:MAXimum:BELOW.....	542
CALCulate<n>:MARKer<m>:SPECTrogram:Y:MAXimum:NEXT.....	542
CALCulate<n>:MARKer<m>:SPECTrogram:Y:MAXimum[:PEAK].....	542
CALCulate<n>:MARKer<m>:SPECTrogram:Y:MINimum:ABOVE.....	543
CALCulate<n>:MARKer<m>:SPECTrogram:Y:MINimum:BELOW.....	543
CALCulate<n>:MARKer<m>:SPECTrogram:Y:MINimum:NEXT.....	543
CALCulate<n>:MARKer<m>:SPECTrogram:Y:MINimum[:PEAK].....	544
CALCulate<n>:MARKer<m>:TRACe.....	527
CALCulate<n>:MARKer<m>:X.....	528
CALCulate<n>:MARKer<m>:X:SLIMits:LEFT.....	531
CALCulate<n>:MARKer<m>:X:SLIMits:RIGHT.....	531
CALCulate<n>:MARKer<m>:X:SLIMits[:STATe].....	531

CALCulate<n>:MARKer<m>:Y:PERCent.....	470
CALCulate<n>:MARKer<m>:Y?.....	539
CALCulate<n>:MARKer<m>[:STATe].....	527
CALCulate<n>:MATH:MODE.....	516
CALCulate<n>:MATH:POSition.....	517
CALCulate<n>:MATH:STATe.....	517
CALCulate<n>:MATH<t>:EXPRession[:DEFine].....	516
CALCulate<n>:PEAKsearch:ADD.....	451
CALCulate<n>:PEAKsearch:AUTO.....	452
CALCulate<n>:PEAKsearch:CLEar[:IMMediate].....	452
CALCulate<n>:PEAKsearch:MARGin.....	453
CALCulate<n>:PEAKsearch:METHod.....	453
CALCulate<n>:PEAKsearch:PLISt<peak>:ALL.....	456
CALCulate<n>:PEAKsearch:PLISt<peak>:COMMENT.....	456
CALCulate<n>:PEAKsearch:PLISt<peak>:DELeTe.....	457
CALCulate<n>:PEAKsearch:PLISt<peak>:DELTA?.....	457
CALCulate<n>:PEAKsearch:PLISt<peak>:DETEctor.....	457
CALCulate<n>:PEAKsearch:PLISt<peak>:FREQUency?.....	458
CALCulate<n>:PEAKsearch:PLISt<peak>:LEVel?.....	458
CALCulate<n>:PEAKsearch:PLISt<peak>:SIZE?.....	459
CALCulate<n>:PEAKsearch:PLISt<peak>:TRACe?.....	459
CALCulate<n>:PEAKsearch:PLISt<peak>[:DATA]?.....	459
CALCulate<n>:PEAKsearch:SUBRanges.....	454
CALCulate<n>:PEAKsearch:SUBRanges:PCOunt.....	453
CALCulate<n>:PEAKsearch[:IMMediate].....	452
CALCulate<n>:PSEarch:ADD.....	451
CALCulate<n>:PSEarch:AUTO.....	452
CALCulate<n>:PSEarch:CLEar[:IMMediate].....	452
CALCulate<n>:PSEarch:MARGin.....	453
CALCulate<n>:PSEarch:METHod.....	453
CALCulate<n>:PSEarch:PLISt<peak>:ALL?.....	456
CALCulate<n>:PSEarch:PLISt<peak>:COMMENT.....	456
CALCulate<n>:PSEarch:PLISt<peak>:DELeTe.....	457
CALCulate<n>:PSEarch:PLISt<peak>:DELTA?.....	457
CALCulate<n>:PSEarch:PLISt<peak>:DETEctor?.....	457
CALCulate<n>:PSEarch:PLISt<peak>:FREQUency?.....	458
CALCulate<n>:PSEarch:PLISt<peak>:LEVel?.....	458
CALCulate<n>:PSEarch:PLISt<peak>:SIZE?.....	459
CALCulate<n>:PSEarch:PLISt<peak>:TRACe?.....	459
CALCulate<n>:PSEarch:PLISt<peak>[:DATA]?.....	459
CALCulate<n>:PSEarch:SUBRanges.....	454
CALCulate<n>:PSEarch:SUBRanges:PCOunt.....	453
CALCulate<n>:PSEarch[:IMMediate].....	452
CALCulate<n>:SGRam:CLEar[:IMMediate].....	518
CALCulate<n>:SGRam:FRAME:SELEct.....	518
CALCulate<n>:SGRam:HDEPth.....	519
CALCulate<n>:SGRam:TRACe.....	519
CALCulate<n>:SGRam:TSTamp:DATA?.....	520
CALCulate<n>:SGRam:TSTamp[:STATe].....	521
CALCulate<n>:SGRam[:STATe].....	521

CALCulate<n>:SPECTrogram:CLEar[:IMMediate].....	518
CALCulate<n>:SPECTrogram:FRAMe:SElect.....	518
CALCulate<n>:SPECTrogram:HDEPth.....	519
CALCulate<n>:SPECTrogram:TRACe.....	519
CALCulate<n>:SPECTrogram:TSTamp:DATA?.....	520
CALCulate<n>:SPECTrogram:TSTamp[:STATe].....	521
CALCulate<n>:SPECTrogram[:STATe].....	521
CALCulate<n>:TFLine:STATe.....	550
CALCulate<n>:THReshold.....	532
CALCulate<n>:THReshold:STATe.....	532
CALCulate<n>:TLINe<tl>.....	550
CALCulate<n>:TLINe<tl>:STATe.....	551
CALCulate<n>:UNIT:POWer.....	493
CALibration:RESult?.....	615
CALibration[:ALL]?.....	614
CONFigure:RECeiver:MEASurement[:DEFault].....	430
DIAGnostic:INFO:CCOunt?.....	657
DIAGnostic:SERVice:BIOSinfo?.....	657
DIAGnostic:SERVice:HWINfo?.....	657
DIAGnostic:SERVice:INPut:MC[:DISTance].....	615
DIAGnostic:SERVice:INPut:PULSed:CFREquency.....	615
DIAGnostic:SERVice:INPut:RF[:SPECTrum].....	616
DIAGnostic:SERVice:INPut:SYNTtwo[:FREQuency].....	616
DIAGnostic:SERVice:INPut[:SElect].....	616
DIAGnostic:SERVice:SFUNction.....	662
DIAGnostic:SERVice:SFUNction:LASTresult?.....	663
DIAGnostic:SERVice:SFUNction:RESults:DELeTe.....	663
DIAGnostic:SERVice:SFUNction:RESults:SAVE.....	663
DIAGnostic:SERVice:SINFo?.....	663
DIAGnostic:SERVice:STESt:RESult?.....	617
DIAGnostic:SERVice:VERSinfo?.....	658
DISPlay:ANNotation:CBAR.....	630
DISPlay:ANNotation:FREQuency.....	630
DISPlay:ATAB.....	422
DISPlay:BARGraph:LEVel:LOWer?.....	438
DISPlay:BARGraph:LEVel:UPPer?.....	438
DISPlay:BARGraph:PHOLd:RESet.....	438
DISPlay:BARGraph:PHOLd[:STATe].....	438
DISPlay:BARGraph:TCOupling[:STATe].....	439
DISPlay:CMAP<item>:DEFault<color>.....	633
DISPlay:CMAP<item>:HSL.....	634
DISPlay:CMAP<item>:PDEFined.....	634
DISPlay:FORMat.....	504
DISPlay:ITERm[:STATe].....	630
DISPlay:LOGO.....	583
DISPlay:MINFo[:STATe].....	529
DISPlay:SBAR[:STATe].....	631
DISPlay:SKEYs[:STATe].....	631
DISPlay:TBAR[:STATe].....	631
DISPlay:THEMe:CATalog?.....	635

DISPlay:THEMe:SElect.....	635
DISPlay:TOUChscreen[::STATe].....	631
DISPlay[:WINDow]:TIME.....	632
DISPlay[:WINDow]:TIME:FORMat.....	632
DISPlay[:WINDow<n>]:MTABLE.....	530
DISPlay[:WINDow<n>]:SGRam:COLor:DEFault.....	522
DISPlay[:WINDow<n>]:SGRam:COLor:LOWer.....	522
DISPlay[:WINDow<n>]:SGRam:COLor:SHAPE.....	522
DISPlay[:WINDow<n>]:SGRam:COLor:UPPer.....	523
DISPlay[:WINDow<n>]:SGRam:COLor[::STYLe].....	523
DISPlay[:WINDow<n>]:SIZE.....	505
DISPlay[:WINDow<n>]:SPECTrogram:COLor:DEFault.....	522
DISPlay[:WINDow<n>]:SPECTrogram:COLor:LOWer.....	522
DISPlay[:WINDow<n>]:SPECTrogram:COLor:SHAPE.....	522
DISPlay[:WINDow<n>]:SPECTrogram:COLor:UPPer.....	523
DISPlay[:WINDow<n>]:SPECTrogram:COLor[::STYLe].....	523
DISPlay[:WINDow<n>]:TRACe<t>:MODE.....	462
DISPlay[:WINDow<n>]:TRACe<t>:SYMBol.....	454
DISPlay[:WINDow<n>]:TRACe<t>:X:SPACing.....	492
DISPlay[:WINDow<n>]:TRACe<t>:Y[::SCALE].....	497
DISPlay[:WINDow<n>]:TRACe<t>:Y[::SCALE]:BOTTom.....	497
DISPlay[:WINDow<n>]:TRACe<t>[::STATe].....	463
DISPlay[:WINDow<n>]:ZOOM:AREA.....	513
DISPlay[:WINDow<n>]:ZOOM[::STATe].....	514
FORMat:DEXPort:DSEParator.....	569
FORMat:DEXPort:HEADer.....	514
FORMat:DEXPort:TRACes.....	515
FORMat[::DATA].....	568
HCOPy:ABORt.....	583
HCOPy:CMAP<item>:DEFault<color>.....	583
HCOPy:CMAP<item>:HSL.....	584
HCOPy:CMAP<item>:PDEFined.....	585
HCOPy:CONTent.....	585
HCOPy:DESTination<device>.....	586
HCOPy:DEVice:COLor.....	586
HCOPy:DEVice:LANGUage<device>.....	587
HCOPy:ITEM:WINDow:TEXT.....	588
HCOPy:MODE.....	595
HCOPy:PAGE:COUNT:STATe.....	588
HCOPy:PAGE:MARGin<device>:BOTTom.....	588
HCOPy:PAGE:MARGin<device>:LEFT.....	589
HCOPy:PAGE:MARGin<device>:RIGHT.....	589
HCOPy:PAGE:MARGin<device>:TOP.....	589
HCOPy:PAGE:MARGin<device>:UNIT.....	590
HCOPy:PAGE:ORlentation<device>.....	590
HCOPy:PAGE:WINDow<device>:CHANnel:STATe.....	590
HCOPy:PAGE:WINDow<device>:COUNT.....	591
HCOPy:PAGE:WINDow<device>:SCALE.....	591
HCOPy:PAGE:WINDow<device>:STATe.....	592
HCOPy:TDSamp:STATe<device>.....	593

HCOPY:TREPort:APPend.....	595
HCOPY:TREPort:DEScription.....	595
HCOPY:TREPort:ITEM:DEFault.....	596
HCOPY:TREPort:ITEM:HEADer:LINE<line>:CONTRol.....	596
HCOPY:TREPort:ITEM:HEADer:LINE<line>:TEXT.....	596
HCOPY:TREPort:ITEM:HEADer:LINE<line>:TITLe.....	597
HCOPY:TREPort:ITEM:HEADer:STATe.....	598
HCOPY:TREPort:ITEM:LIST?.....	598
HCOPY:TREPort:ITEM:LOGO.....	598
HCOPY:TREPort:ITEM:LOGO:CONTRol.....	599
HCOPY:TREPort:ITEM:SELect.....	599
HCOPY:TREPort:ITEM:TEMPlate:CATalog?.....	602
HCOPY:TREPort:ITEM:TEMPlate:DELete.....	602
HCOPY:TREPort:ITEM:TEMPlate:LOAD.....	602
HCOPY:TREPort:ITEM:TEMPlate:SAVE.....	603
HCOPY:TREPort:NEW.....	603
HCOPY:TREPort:PAGecount:STATe.....	603
HCOPY:TREPort:PAGesize.....	603
HCOPY:TREPort:PCOLors[:STATe].....	604
HCOPY:TREPort:TDSTamp[:STATe].....	604
HCOPY:TREPort:TEST:REMOve.....	604
HCOPY:TREPort:TEST:REMOve:ALL.....	605
HCOPY:TREPort:TITLe.....	605
HCOPY:TREPort:TITLe:STATe.....	606
HCOPY[:IMMEDIATE<device>].....	587
HCOPY[:IMMEDIATE<device>]:NEXT.....	588
HOLD.....	427
INITiate<n>:CONMeas.....	427
INITiate<n>:CONTInuous.....	428
INITiate<n>:EMITest.....	429
INITiate<n>:FMEasurement.....	429
INITiate<n>:SEQuencer:ABORT.....	430
INITiate<n>:SEQuencer:IMMEDIATE.....	431
INITiate<n>:SEQuencer:MODE.....	431
INITiate<n>[:IMMEDIATE].....	429
INPut:TERMinator.....	632
INPut<ip>:ATTenuation.....	494
INPut<ip>:ATTenuation:AMODE.....	494
INPut<ip>:ATTenuation:AUTO.....	494
INPut<ip>:ATTenuation:LIMiter[:STATe].....	475
INPut<ip>:ATTenuation:PROTection[:STATe].....	495
INPut<ip>:COUPling.....	473
INPut<ip>:GAIN:AUTO.....	495
INPut<ip>:GAIN:LNA:AUTO.....	495
INPut<ip>:GAIN:LNA:STATe.....	496
INPut<ip>:GAIN:STATe.....	496
INPut<ip>:IMPedance.....	474
INPut<ip>:LISN:FILTer:HPASS[:STATe].....	469
INPut<ip>:LISN:PHASe.....	469
INPut<ip>:LISN[:TYPE].....	470

INPut<ip>:PRESelection:FILTer:NOTCh<filter>[:STATe].....	475
INPut<ip>:PRESelection:FILTer:SPLit[:STATe].....	476
INPut<ip>:PRESelection[:STATe].....	476
INPut<ip>:TYPE.....	474
INPut<ip>:UPORt:STATe.....	482
INPut<ip>:UPORt[:VALue].....	482
INSTRument:COUPle:ACDC.....	637
INSTRument:COUPle:ATTen.....	638
INSTRument:COUPle:BANDwidth.....	638
INSTRument:COUPle:BWIDth.....	638
INSTRument:COUPle:CENTer.....	638
INSTRument:COUPle:DEMod.....	639
INSTRument:COUPle:GAIN.....	639
INSTRument:COUPle:LIMit.....	639
INSTRument:COUPle:LLINes.....	639
INSTRument:COUPle:MARKer.....	640
INSTRument:COUPle:PRESel.....	640
INSTRument:COUPle:PROT.....	640
INSTRument:COUPle:SPAN.....	641
INSTRument:COUPle:USER<j>.....	642
INSTRument:COUPle:USER<j>:CHANnel:LIST?.....	642
INSTRument:COUPle:USER<j>:ELEMeNt:LIST?.....	643
INSTRument:COUPle:USER<j>:INFO?.....	644
INSTRument:COUPle:USER<j>:NEW?.....	644
INSTRument:COUPle:USER<j>:NUMBers:LIST?.....	646
INSTRument:COUPle:USER<j>:RELation.....	647
INSTRument:COUPle:USER<j>:REMOve.....	647
INSTRument:COUPle:USER<j>:STATe.....	648
INSTRument:COUPle:USER<j>:WINDow:LIST?.....	648
INSTRument:COUPle:VBW.....	641
INSTRument:CREate:DUPLicate.....	423
INSTRument:CREate:REPLace.....	423
INSTRument:CREate[:NEW].....	423
INSTRument:DELeTe.....	424
INSTRument:LIST?.....	424
INSTRument:REName.....	425
INSTRument[:SELeCt].....	425
LAYout:ADD[:WINDow]?.....	505
LAYout:CATalog[:WINDow]?.....	506
LAYout:IDENtify[:WINDow]?.....	507
LAYout:REMOve[:WINDow].....	507
LAYout:REPLace[:WINDow].....	507
LAYout:SPLitter.....	508
LAYout:WINDow<n>:ADD?.....	509
LAYout:WINDow<n>:IDENtify?.....	510
LAYout:WINDow<n>:REMOve.....	510
LAYout:WINDow<n>:REPLace.....	510
MMEMory:CATalog:LONG?.....	570
MMEMory:CATalog?.....	569
MMEMory:CDIRectory.....	571



MMEMory:CLEar:ALL.....	578
MMEMory:CLEar:STATe.....	579
MMEMory:COMMeNt.....	571
MMEMory:COpy.....	571
MMEMory:DATA.....	571
MMEMory:DELeTe.....	572
MMEMory:LOAD:AUTO.....	579
MMEMory:LOAD:STATe.....	579
MMEMory:LOAD<n>:LIMit.....	556
MMEMory:LOAD<n>:TFACtor.....	619
MMEMory:MDIRectory.....	572
MMEMory:MOVe.....	572
MMEMory:MSIS.....	573
MMEMory:NAME.....	573
MMEMory:NETWork:DISConnect.....	573
MMEMory:NETWork:MAP.....	574
MMEMory:NETWork:UNUSeddrives?.....	574
MMEMory:NETWork:USEDdrives?.....	575
MMEMory:RDIRectory.....	575
MMEMory:SELeCt:CHANnel[:ITEM]:ALL.....	576
MMEMory:SELeCt:CHANnel[:ITEM]:DEFault.....	576
MMEMory:SELeCt:CHANnel[:ITEM]:HWSettings.....	576
MMEMory:SELeCt:CHANnel[:ITEM]:LINES:ALL.....	577
MMEMory:SELeCt:CHANnel[:ITEM]:NONE.....	577
MMEMory:SELeCt:CHANnel[:ITEM]:SGRam.....	577
MMEMory:SELeCt:CHANnel[:ITEM]:TRACe[:ACTive].....	578
MMEMory:SELeCt:CHANnel[:ITEM]:TRANSDucer:ALL.....	578
MMEMory:SELeCt[:ITEM]:ALL.....	576
MMEMory:SELeCt[:ITEM]:DEFault.....	576
MMEMory:SELeCt[:ITEM]:HWSettings.....	576
MMEMory:SELeCt[:ITEM]:LINES:ALL.....	577
MMEMory:SELeCt[:ITEM]:NONE.....	577
MMEMory:SELeCt[:ITEM]:SGRam.....	577
MMEMory:SELeCt[:ITEM]:TRACe[:ACTive].....	578
MMEMory:SELeCt[:ITEM]:TRANSDucer:ALL.....	578
MMEMory:STORe:FINAl.....	455
MMEMory:STORe:PLISt.....	455
MMEMory:STORe<n>:LIMit.....	556
MMEMory:STORe<n>:SGRam.....	606
MMEMory:STORe<n>:SPECTrogram.....	606
MMEMory:STORe<n>:STATe.....	580
MMEMory:STORe<n>:STATe:NEXt.....	581
MMEMory:STORe<n>:TFACtor.....	619
MMEMory:STORe<n>:TRACe.....	607
MMEMory:STORe<n>:TYPE.....	581
OUTPut:PROBe<probe>[:POWeR].....	488
OUTPut:TRIGger<port>:DIRectioN.....	489
OUTPut:TRIGger<port>:LEVeL.....	489
OUTPut:TRIGger<port>:OTYPe.....	489
OUTPut:TRIGger<port>:PULSe:IMMeDiate.....	490

OUTPut:TRIGger<port>:PULSe:LENGth.....	490
OUTPut:UPORt:STATe.....	483
OUTPut:UPORt[:VALue].....	482
OUTPut<i>:IF:AUDio.....	483
OUTPut<i>:IF:COUPling.....	484
OUTPut<i>:IF:IFFrequency.....	484
OUTPut<i>:IF:LPASs:FREQUency:MANual.....	484
OUTPut<i>:IF:LPASs[:STATe].....	485
OUTPut<i>:IF:SCALE.....	485
OUTPut<i>:IF[:SOURce].....	486
OUTPut<i>:LINK.....	486
SOURce:EXTernal:FREQUency.....	477
SOURce:EXTernal:FREQUency:COUPling[:STATe].....	477
SOURce:EXTernal:FREQUency:OFFSet.....	478
SOURce:EXTernal:FREQUency[:FACTor]:DENominator.....	477
SOURce:EXTernal:FREQUency[:FACTor]:NUMerator.....	478
SOURce:EXTernal:POWer[:LEVel].....	479
SOURce:EXTernal:ROSCillator:EXTernal:FREQUency.....	612
SOURce:EXTernal:ROSCillator[:SOURce].....	479
SOURce:EXTernal[:STATe].....	479
SOURce:POWer[:LEVel][:IMMEDIATE]:OFFSet.....	479
SOURce:TEMPerature:FRONtend?.....	617
STATus:OPERation:CONDition?.....	665
STATus:OPERation:ENABle.....	667
STATus:OPERation:NTRansition.....	667
STATus:OPERation:PTRansition.....	668
STATus:OPERation[:EVENT]?.....	666
STATus:PRESet.....	665
STATus:QUESTionable:ACPLimit:CONDition?.....	665
STATus:QUESTionable:ACPLimit:ENABle.....	667
STATus:QUESTionable:ACPLimit:NTRansition.....	667
STATus:QUESTionable:ACPLimit:PTRansition.....	668
STATus:QUESTionable:ACPLimit[:EVENT]?.....	666
STATus:QUESTionable:CONDition?.....	665
STATus:QUESTionable:ENABle.....	667
STATus:QUESTionable:EXTended:CONDition?.....	666
STATus:QUESTionable:EXTended:ENABle.....	667
STATus:QUESTionable:EXTended:INFO:CONDition?.....	666
STATus:QUESTionable:EXTended:INFO:ENABle.....	667
STATus:QUESTionable:EXTended:INFO:NTRansition.....	667
STATus:QUESTionable:EXTended:INFO:PTRansition.....	668
STATus:QUESTionable:EXTended:INFO[:EVENT]?.....	666
STATus:QUESTionable:EXTended:NTRansition.....	667
STATus:QUESTionable:EXTended:PTRansition.....	668
STATus:QUESTionable:EXTended[:EVENT]?.....	666
STATus:QUESTionable:FREQUency:CONDition?.....	666
STATus:QUESTionable:FREQUency:ENABle.....	667
STATus:QUESTionable:FREQUency:NTRansition.....	667
STATus:QUESTionable:FREQUency:PTRansition.....	668
STATus:QUESTionable:FREQUency[:EVENT]?.....	666

STATus:QUESTionable:LIMit<n>:CONDition?	666
STATus:QUESTionable:LIMit<n>:ENABle	667
STATus:QUESTionable:LIMit<n>:NTRansition	667
STATus:QUESTionable:LIMit<n>:PTRansition	668
STATus:QUESTionable:LIMit<n>[:EVENT]?	666
STATus:QUESTionable:LMARgin<n>:CONDition?	666
STATus:QUESTionable:LMARgin<n>:ENABle	667
STATus:QUESTionable:LMARgin<n>:NTRansition	667
STATus:QUESTionable:LMARgin<n>:PTRansition	668
STATus:QUESTionable:LMARgin<n>[:EVENT]?	666
STATus:QUESTionable:NTRansition	667
STATus:QUESTionable:POWer:CONDition?	666
STATus:QUESTionable:POWer:ENABle	667
STATus:QUESTionable:POWer:NTRansition	667
STATus:QUESTionable:POWer:PTRansition	668
STATus:QUESTionable:POWer[:EVENT]?	666
STATus:QUESTionable:PTRansition	668
STATus:QUESTionable:TEMPerature:CONDition?	666
STATus:QUESTionable:TEMPerature:ENABle	667
STATus:QUESTionable:TEMPerature:NTRansition	668
STATus:QUESTionable:TEMPerature:PTRansition	668
STATus:QUESTionable:TEMPerature[:EVENT]?	666
STATus:QUESTionable:TIME:CONDition?	666
STATus:QUESTionable:TIME:ENABle	667
STATus:QUESTionable:TIME:NTRansition	668
STATus:QUESTionable:TIME:PTRansition	668
STATus:QUESTionable:TIME[:EVENT]?	666
STATus:QUESTionable:TRANSDucer:CONDition?	666
STATus:QUESTionable:TRANSDucer:ENABle?	667
STATus:QUESTionable:TRANSDucer:NTRansition?	668
STATus:QUESTionable:TRANSDucer:PTRansition?	668
STATus:QUESTionable:TRANSDucer[:EVENT]?	666
STATus:QUESTionable[:EVENT]?	666
STATus:QUEEue[:NEXT]?	665
SYSTem:CLOGging	610
SYSTem:COMMunicate:GPIB:RDEvice:GENerator:ADDRess	480
SYSTem:COMMunicate:GPIB[:SELF]:ADDRess	650
SYSTem:COMMunicate:GPIB[:SELF]:RTERminator	650
SYSTem:COMMunicate:PRINter:ENUMerate:FIRST?	593
SYSTem:COMMunicate:PRINter:ENUMerate[:NEXT]?	593
SYSTem:COMMunicate:PRINter:SElect<device>	594
SYSTem:COMMunicate:RDEvice:GENerator:INTerface	480
SYSTem:COMMunicate:RDEvice:GENerator:LINK	480
SYSTem:COMMunicate:RDEvice:GENerator:TYPE	481
SYSTem:COMMunicate:TCPip:RDEvice:GENerator:ADDRess	481
SYSTem:DISPlay:FPANel[:STATe]	633
SYSTem:DISPlay:MESSage:STATe	650
SYSTem:DISPlay:MESSage[:TEXT]	650
SYSTem:DISPlay:UPDate	651
SYSTem:ERRor:CLEar:ALL	658

SYSTem:ERRor:CLEar:REMOte.....	651
SYSTem:ERRor:DISPLay.....	651
SYSTem:ERRor:EXTended?.....	659
SYSTem:ERRor:LIST?.....	659
SYSTem:ERRor[:NEXT]?.....	660
SYSTem:FIRMWare:UPDate.....	660
SYSTem:FORMat:IDENt.....	660
SYSTem:HPCoupling.....	652
SYSTem:IDENtify:FACTory.....	652
SYSTem:IDENtify[:STRing].....	653
SYSTem:IFGain:MODE.....	652
SYSTem:KLOCK.....	653
SYSTem:LANGUage.....	653
SYSTem:LXI:INFO?.....	653
SYSTem:LXI:LANReset.....	654
SYSTem:LXI:MDEscription.....	654
SYSTem:LXI:PASSword.....	654
SYSTem:PASSword:RESet.....	664
SYSTem:PASSword[:CENable].....	664
SYSTem:PRESet.....	582
SYSTem:PRESet:CHANnel[:EXEC].....	582
SYSTem:PRESet:COMPatible.....	661
SYSTem:PRESet:FILTer.....	661
SYSTem:PSA:WIDeband.....	654
SYSTem:REBoot.....	610
SYSTem:REVisiOn:FACTory.....	655
SYSTem:REVisiOn[:STRing].....	655
SYSTem:RSWeep.....	656
SYSTem:SECurity[:STATe].....	661
SYSTem:SEQuencer.....	432
SYSTem:SHUTdown.....	611
SYSTem:SPEaker:MAXVolume.....	487
SYSTem:SPEaker:MUTE.....	488
SYSTem:SPEaker:VOLume.....	488
TRACe<n>:COPY.....	515
TRACe<n>:FEED:CONTRol<t>.....	436
TRACe<n>:IF[:DATA].....	437
TRACe<n>:POINts.....	437
TRACe<n>[:DATA].....	436
TRIGger<n>[:SEQuence]:HOLDoff[:TIME].....	502
TRIGger<n>[:SEQuence]:LEVel[:EXTernal<port>].....	502
TRIGger<n>[:SEQuence]:SLOPe.....	503
TRIGger<n>[:SEQuence]:SOURce.....	503

# Index

## Symbols

*IDN	
Format	390
*OPC	364
*OPC?	364
*RST	382
*WAI	364
9.91E37	
Remote control	362
75 Ω (channel bar)	57

## A

AC (trace information)	58
AC/DC coupling	142
Alignment	
Basics	289
Performing	293, 294
Results	290, 291, 293
Settings	291
touchscreen	290, 293
Touchscreen	291
Alphanumeric keys	47
Alphanumeric parameters	67
Analog Demodulation	
Application	83
Annotations	
Hiding/restoring	297
AP (trace information)	58
Application cards	17
Application notes	17
Applications	
Analog Demodulation	83
CISPR APD	83
I/Q Analyzer	83
Real-Time Spectrum	83
Receiver	82
Spectrum	83
APX	
External generator	151
Arranging	
Windows	74, 187
AS (trace information)	58
ASCII trace export	216
Attenuation	115, 116
Attenuation (channel bar)	56
Auto range	115
Automatic coupling	
Frequencies, external generator	149, 155
Automatic login mechanism	
Activating/Deactivating	405
AUX control	
TTL synchronization, external generator	145
AUX PORT	
Connector	52
AV (trace information)	58

## B

Bandwidth	96, 97, 114
-----------	-------------

Bargraph	
Bandwidth	96, 114
Detector	127
Measurement time	95, 115
Bargraph frequency	156
Block data	360
Boolean parameters	359
Brackets	360
Brochures	17

## C

Calibration	
Frequency	331
Frequency MW	332
Frequency RF	332
Remote	418
Remote control	614
Results (remote control)	615
RF	332
Settings	331
Signal	331
Case-sensitivity	
SCPI	356
Channel	
Creating (remote)	423, 425
Deleting (remote)	424
Duplicating (remote)	423
Querying (remote)	424
Renaming (remote)	425
Replacing (remote)	423
Selecting (remote)	425
Channel bar	
Hiding/restoring	297
Information	55
Information, external generator	151
channel settings	
Presetting	249
Channel settings	
Display	55
Channels	
Duplicating	85
New	85
Replacing	85
see also Measurement channels	69
Sequential operation	85
Switching	55
CISPR APD	
Application	83
Cleaning	711
Clear status	
Remote	418
Closing	
Channels	70
Channels (remote)	424
Windows	73, 186
Windows (remote)	507, 510
CLRW (trace information)	58
Colon	360
Color curve	
Shape	201, 210
Spectrograms	201, 215

- Color mapping
  - Color curve ..... 210
  - Color range ..... 210, 211
  - Color scheme ..... 211
  - Softkey ..... 209
  - Spectrograms ..... 200, 209, 213, 214
  - Step by step ..... 213
  - Value range ..... 200
- Color scheme
  - Spectrogram ..... 200, 211
- Colors
  - Assigning to object ..... 301
  - Configuring ..... 301, 303
  - Display ..... 299
  - Editing ..... 299
  - Predefined ..... 302
  - Print ..... 301
  - Printing ..... 299
  - Restoring ..... 302
  - Screen ..... 300
  - User-defined ..... 301
  - User-specific ..... 302
- Comma ..... 360
- Command sequence
  - Recommendation ..... 382
  - Remote ..... 421
- Commands ..... 354
  - Brackets ..... 360
  - Colon ..... 360
  - Comma ..... 360
  - Command line structure ..... 361
  - Common ..... 354
  - Double dagger ..... 360
  - GBIP, addressed ..... 352
  - GBIP, universal ..... 352
  - Instrument control ..... 354
  - Overlapping ..... 363
  - Question mark ..... 360
  - Quotation mark ..... 360
  - SCPI confirmed ..... 354
  - Sequential ..... 363
  - Syntax elements ..... 360
  - Tracking ..... 390
  - Vertical stroke ..... 360
  - White space ..... 360
- Comment
  - Limit lines ..... 241
  - Screenshots ..... 272
  - Softkey ..... 272
- Common commands
  - Syntax ..... 355
- Compatibility
  - FSQ, FSP, FSU, FSV ..... 391
  - GPIB ..... 390
  - Limit lines ..... 233, 238
  - Mode ..... 391
- Computer name ..... 387
  - Changing ..... 36
- CONDition ..... 367
- Connector
  - AC power supply ..... 50
  - AUX PORT ..... 52
  - Display Port ..... 51
  - DVI ..... 51
  - GPIB interface ..... 52
  - Headphones ..... 44
  - IF/VIDEO/DEMOM ..... 51
  - LAN ..... 51
  - Probe power ..... 44
  - REF INPUT ..... 53
  - USB ..... 51
- Connectors
  - AUX control, external generator ..... 145
  - EXT REF ..... 320
  - External generator control ..... 145
  - External generators ..... 52
  - GPIB ..... 145
  - OCHO ..... 53
  - REF OUTPUT ..... 322
  - SYNC TRIGGER ..... 51, 320
  - Trigger Input ..... 45
  - Trigger Output ..... 45
  - USB ..... 43
- Context-sensitive menus ..... 65
- Continuous Sequencer
  - Softkey ..... 88
- Conventions
  - SCPI commands ..... 416
- Copying
  - Channel (remote) ..... 423
  - Traces ..... 205
- Coupling
  - Automatic, external generator ..... 149, 155
  - Frequencies, external generator ..... 149
  - GPIB ..... 392
  - GPIB (remote control) ..... 652
  - Manual, external generator ..... 155
- Cursor keys ..... 45, 46
- D**
  - Data format
    - ASCII ..... 524
    - Binary ..... 524
    - Remote ..... 514, 515, 568
  - Data sheets ..... 17
  - Date
    - Format ..... 295
    - Hiding/restoring ..... 297
    - Instrument setting ..... 295
    - Setting ..... 37
  - Date and Time
    - Printing ..... 272
  - DCL ..... 352
  - Debugging
    - Remote control programs ..... 716
  - Decimal separator
    - Trace export ..... 204
  - DEF ..... 358
  - Default
    - Restoring settings ..... 248
  - Default values
    - Remote ..... 420
  - Deleting
    - Limit line values ..... 242
  - Delta markers ..... 224
    - Defining ..... 224
  - Demodulation
    - Squelch ..... 159
  - Denominator
    - Frequencies, external generator ..... 149, 155
  - Device
    - Softkey ..... 272, 274, 276
  - Device-specific commands ..... 354

- DHCP ..... 34, 388, 398
- DHCP server
  - LAN configuration ..... 36
- Diagnostics
  - Hardware ..... 334
- Diagram area
  - Status display ..... 59
  - Trace information ..... 57
- Diagram footer ..... 59
- Hiding/restoring ..... 297
- Dialog boxes
  - Slider ..... 66
  - Transparency ..... 66
- Dialogs
  - Printing ..... 272
  - Suppressing file selection ..... 275
- Display
  - Colors ..... 299, 303
  - Config (softkey) ..... 182
  - Evaluation bar ..... 73, 186
  - Evaluation methods ..... 182
  - Information ..... 54
  - Settings ..... 294
  - SmartGrid ..... 70, 183
  - Theme ..... 299
  - Update (remote) ..... 389
  - Update rate ..... 295
- Display lines ..... 231
  - Defining ..... 232
  - Settings ..... 231
- Display Port
  - Connector ..... 51
- Displayed items
  - Touchscreen ..... 296
- DNS server
  - IP Address ..... 400
  - LAN configuration ..... 36
- Double dagger ..... 360
- DOWN ..... 358
- Duplicating
  - Channel (remote) ..... 423
- DVI
  - Connector ..... 51
- E**
- Electrostatic discharge ..... 19
- ENABLE ..... 367
- Enable registers
  - Remote ..... 420
- Entering data ..... 66
- ENV216 (LISN) ..... 100, 129
- ENV432 (LISN) ..... 100
- ENV4200 (LISN) ..... 100, 129
- EOI
  - GPIO terminator ..... 389
- Error log ..... 80, 718
- Error messages
  - Status bar ..... 60, 713
- Error queue ..... 369
- Errors
  - External generator ..... 151
  - IF OVLD ..... 61, 377, 714
  - INPUT OVLD ..... 61, 377, 714
  - LOUNL ..... 61, 714
  - Messages, device-specific ..... 715
  - NO REF ..... 62, 714
  - OVEN ..... 62, 714
  - Queues, recommendations ..... 383
  - Remote control programming ..... 383
  - RF OVLD ..... 62, 377, 714
  - UNCAL ..... 62, 714
  - UNLD ..... 377
  - WRONG\_FW ..... 62, 289, 325, 714
- ESD ..... 19
- ESE (event status enable register ) ..... 370
- ESH2-Z5 (LISN) ..... 100, 129
- ESH3-Z5 (LISN) ..... 100, 129
- ESR (event status register) ..... 370
- Evaluation
  - Modes ..... 182
  - Modes, adding ..... 73, 186
- Evaluation bar
  - Using ..... 73, 186
- Evaluation methods
  - Remote ..... 505
- EVENT ..... 367
- Event status enable register (ESE) ..... 370
  - Remote ..... 418
- Event status register (ESR) ..... 366, 370
  - Remote ..... 418
- Export format
  - Traces ..... 216
- Exporting
  - Data ..... 262, 264
  - Functions ..... 255
  - I/Q data ..... 262, 264, 268
  - Measurement settings ..... 204
  - Softkey ..... 261, 263
  - Trace data ..... 211
  - Traces ..... 205, 262, 264
- EXREF (status display) ..... 62, 714
- EXT REF
  - Status message ..... 60
- Ext.Gen (channel bar) ..... 57
- External generator ..... 144
  - Activating/Deactivating ..... 154
  - Basics ..... 144
  - Calibration measurement settings ..... 154
  - Channel bar information ..... 151
  - Connections ..... 145
  - Coupling frequencies ..... 149
  - Errors ..... 151
  - Generators, supported ..... 147
  - Interface ..... 153
  - Interface settings ..... 152
  - Overloading ..... 152
  - Reflection measurement ..... 146
  - Settings ..... 152
  - Transmission measurement ..... 146
  - TTL synchronization ..... 145
- External generators ..... 52
- External monitor
  - Connectors ..... 51
- External reference
  - External generator ..... 147
  - External generator control ..... 153
  - Frequency ..... 322
  - Input ..... 320
  - Loop bandwidth ..... 322
  - Missing ..... 321
  - Output ..... 322
  - Settings ..... 320

- Status message ..... 60
- Tuning range ..... 321
- External trigger ..... 179
- EZ-27 (LISN adapter) ..... 100, 129
- F**
- File format
  - Export Files ..... 216
  - Trace export ..... 216
- File type
  - Storage settings ..... 257
- filename
  - Data files ..... 255
  - Settings ..... 256, 259
- Files
  - Format, I/Q data ..... 264
  - I/Q data binary XML ..... 268
  - I/Q parameter XML ..... 265
- Filter ..... 96
- Final measurement ..... 107
  - Bandwidth ..... 96, 114
  - Detector ..... 127
  - Measurement time ..... 95, 115
- Firmware
  - Updating ..... 325
- Firmware Update
  - Remote control ..... 660
- Firmware updates
  - see User Manual ..... 19
- Focus
  - Changing ..... 66
- Format
  - Data ..... 524
  - Data (remote) ..... 514, 515, 568
  - Date and time ..... 295
  - see also File format ..... 216
- Frames
  - Spectrogram marker ..... 224
- Free Run
  - Trigger ..... 179
- Frequency ..... 171
  - External generator ..... 155
  - External reference ..... 322
  - Reference ..... 320
  - Step size ..... 114
- Frequency (channel bar) ..... 57
- Frequency axis
  - Scaling ..... 169
- Frequency coupling
  - Automatic, external generator ..... 149
  - External generator ..... 149, 155
  - Reverse sweep, external generator ..... 150
  - TTL synchronization, external generator ..... 150
- Frequency denominator
  - External generator ..... 155
- Frequency numerator
  - External generator ..... 155
- Frequency offset
  - External generator ..... 149, 155
- Frequency range ..... 112, 168, 172
  - Calibration sweep, external generator ..... 149
- Frequency step size ..... 98
- Frequency stepsize ..... 173
- Frequency-converting measurements
  - External generator ..... 149
- Front panel
  - Hiding/restoring ..... 297
- Frontend
  - Temperature ..... 290
  - Temperature (remote) ..... 617
- FRQ
  - External generator ..... 151
- Full screen mode ..... 43
- Function keys
  - Details - see User Manual ..... 48
  - Overview ..... 48
- G**
- Gain level ..... 116
- Gate
  - Delay ..... 180
  - Length ..... 181
  - Measurements ..... 175
  - Mode ..... 180
- Gated trigger
  - Activating ..... 180
  - Delay ..... 180
  - Length ..... 181
  - Mode ..... 180
- Generator
  - Frequencies, external generator ..... 149, 155
  - Frequency coupling, external generator ..... 155
  - Frequency offset, external generator ..... 155
  - Output power, external generator ..... 154
- Generator type
  - External generator ..... 153
- Generators
  - Frequency range, external generator ..... 154
  - Power range, external generator ..... 154
  - Setup files, external generator ..... 149, 153
  - Supported, external generator ..... 147
- GET ..... 352
- Getting started ..... 16
- GPIB ..... 345
  - Address ..... 389, 403
  - Address, External generator ..... 153
  - Characteristics ..... 350
  - Coupling ..... 392
  - External generator ..... 153
  - IF Gain (remote control) ..... 652
  - interface messages ..... 350
  - Language ..... 391
  - Language (remote control) ..... 653
  - Settings ..... 388
  - Terminator ..... 389
  - TTL synchronization, External generator ..... 153
- GPIB bus control
  - Remote ..... 419
- GPIB interface
  - Configuring - see User Manual ..... 52
  - Connector ..... 52
  - Remote control ..... 79
- GPIB Language ..... 383
- Grid scale ..... 168
- GTL ..... 352
- H**
- Hard drive ..... 50



- Hardware
    - Check ..... 325
    - Diagnostics ..... 334
    - Information ..... 323
    - Supported ..... 325
  - Headphones ..... 44
  - Help ..... 76
    - Search for topic ..... 77
    - Using ..... 77
  - Hiding/restoring
    - Display items ..... 296
  - HiSLIP ..... 346
    - Protocol ..... 347
    - Resource string ..... 346
  - History
    - Spectrograms ..... 208
  - History Depth
    - Softkey ..... 208
  - Horizontal Line 1/2
    - Softkeys ..... 232
  - HP emulation ..... 676
- I**
- I/O Logging ..... 390
  - I/Q Analyzer
    - Application ..... 83
  - I/Q data
    - Export file binary data description ..... 268
    - Export file parameter description ..... 265
    - Exporting ..... 262, 264
    - Importing/Exporting ..... 262
  - ID String User ..... 383
  - Identification
    - Remote ..... 419
    - String, R&S ESW ..... 389
    - String, resetting (R&S ESW) ..... 389
  - IEC/IEEE bus
    - see GPIB ..... 345
  - IECWIN ..... 385
    - Accessing ..... 29
  - IF analysis ..... 105, 172
  - IF Gain
    - GPIB ..... 392
    - GPIB (remote control) ..... 652
  - IF OVLD
    - Error ..... 61, 714
    - External generator ..... 151
  - IF OVLD (status display) ..... 61, 714
  - IF/VIDEO/DEMODO
    - Connector ..... 51
  - IFC ..... 352
  - Impedance
    - Setting ..... 142
  - Importing
    - Functions ..... 255
    - I/Q data ..... 262, 265
    - Softkey ..... 263
  - INF ..... 358
  - Information
    - Hardware ..... 323
    - Options ..... 323
    - Version ..... 323
  - Input ..... 117
    - Coupling ..... 142
  - Input (channel bar) ..... 56
  - INPUT OVLD
    - Error ..... 61, 714
  - INPUT OVLD (status display) ..... 61, 714
  - Inserting
    - Limit line values ..... 242
  - Installing
    - Options ..... 324, 325
  - Instrument messages ..... 354
  - Instrument name
    - Changing ..... 401
  - Instrument settings
    - Secure user mode ..... 252
  - Interface messages ..... 354
  - Interfaces
    - GPIB ..... 350
    - LAN ..... 345
    - USB ..... 352
  - Interrupt ..... 379
  - Invalid results
    - Remote control ..... 362
  - IP address ..... 346
    - Assigning ..... 398
    - Changing ..... 34
    - Network ..... 388
  - IP Address
    - DNS server ..... 400
  - IP configuration
    - LXI ..... 402
  - IST ..... 366
  - IST flag ..... 370
    - Remote ..... 419
  - Items
    - Saving ..... 254, 255
    - Settings ..... 257
- K**
- Key
    - Power ..... 43
    - Redo ..... 46
    - Undo ..... 46
  - Keyboard
    - On-screen ..... 65
  - Keypad ..... 67
    - Key layout ..... 68
    - Overview ..... 47
  - Keys
    - MKR ..... 222
    - MKR → ..... 226
    - Peak Search ..... 230
    - PRESET ..... 248
  - Keywords
    - see Mnemonics ..... 355
- L**
- LAN
    - Configuration ..... 32
    - Configuration - see user Manual ..... 19
    - Configuring ..... 401
    - Connector ..... 51
    - Interface ..... 345
    - IP address ..... 346
    - Remote control interface ..... 344
    - Reset ..... 395
    - VISA ..... 346
    - VXI protocol ..... 347

- Legacy format
  - \*IDN ..... 390
- LFE0I
  - GPIB terminator ..... 389
- Limit check
  - Activating/Deactivating ..... 243
  - Results ..... 235
- Limit line ..... 121
- Limit lines ..... 233, 237
  - Activating/Deactivating ..... 238
  - Comment ..... 241
  - Compatibility ..... 233, 238
  - Compatible ..... 243
  - Copying ..... 239, 244
  - Creating ..... 239, 244
  - Data points ..... 242
  - Deactivating ..... 240
  - Defining ..... 243
  - Deleting ..... 240, 244
  - Deleting values ..... 242
  - Details ..... 240
  - Editing ..... 239, 243
  - Inserting values ..... 242
  - Managing ..... 237
  - Margin ..... 241
  - Margins ..... 234
  - Name ..... 240
  - Offsets ..... 235
  - Peak search ..... 227
  - Recalling ..... 252
  - Saving ..... 242, 252, 255
  - Selecting ..... 239
  - Shifting ..... 235, 242, 245
  - Storing ..... 237
  - Threshold ..... 234, 241
  - Traces ..... 238
  - View filter ..... 239
  - Violation ..... 235
  - Visibility ..... 238
  - X-axis ..... 241
  - X-Offset ..... 239
  - Y-axis ..... 241
  - Y-Offset ..... 239
- Limit margin ..... 117, 120
- Linear scaling
  - X-axis ..... 169
- Lines
  - Configuration ..... 237
  - Display ..... 231, 232
  - Horizontal ..... 232
  - Limit, see Limit lines ..... 237
  - Vertical ..... 232
- LISN ..... 100, 129, 160
- LISN (channel bar) ..... 56
- LLO ..... 352
- Loading
  - Functions ..... 255
  - Instrument settings ..... 259
  - Settings ..... 251, 252
- Logarithmic scaling
  - Sweep points ..... 169
  - X-axis ..... 169
- Login
  - Network ..... 404
  - Operating system ..... 26
  - Secure user mode ..... 27
- Logo
  - Printing ..... 272
- Loop bandwidth
  - External reference ..... 322
- LOUNL
  - Error ..... 61, 714
- LOUNL (status display) ..... 61, 714
- LVL
  - External generator ..... 151
- LXI
  - Browser interface ..... 401
  - Configuration ..... 394
  - LAN configuration ..... 402
  - Manufacturer Description ..... 394
  - Password ..... 394
  - Ping ..... 403
  - Remote control ..... 78, 348
  - Reset (LCI) ..... 395
  - Settings ..... 393
- M**
- Maintenance ..... 711
- Margins
  - Limit lines ..... 234, 241
  - Violation ..... 235
- Marker
  - Information ..... 58
  - Search area (softkey) ..... 229
  - Search type (softkey) ..... 229
- Marker table
  - Information ..... 58
- Marker to Trace ..... 224
- Markers
  - Assigned trace ..... 224
  - Basic settings ..... 223
  - Configuration (softkey) ..... 223, 225
  - Deactivating ..... 225
  - Delta markers ..... 224
  - Minimum ..... 230
  - Next minimum ..... 230
  - Next peak ..... 230
  - Peak ..... 230
  - Position ..... 223
  - Querying position (remote) ..... 539
  - Spectrograms ..... 199, 213
  - State ..... 223
  - Table ..... 225
  - Tips ..... 218
  - Type ..... 224
  - X-value ..... 223
- MAX ..... 358
- MAXH (trace information) ..... 58
- Maximize
  - Window ..... 75
- Maximizing
  - Windows (remote) ..... 505
- Meas BW (channel bar) ..... 56
- Meas Time (channel bar) ..... 56
- Measurement
  - Continuous ..... 107
  - Single ..... 107
- Measurement bandwidth ..... 96, 97, 114
- Measurement channels
  - Activating ..... 69
  - Closing ..... 70
- Measurement points ..... 98

- Measurement time ..... 95, 115
- Measurements
  - Evaluation methods ..... 182
- Menus
  - Context-sensitive ..... 65
- Messages
  - Commands ..... 354
  - Instrument ..... 354
  - Instrument responses ..... 355
  - Interface ..... 354
- MI (trace information) ..... 58
- Microsoft Windows ..... 25
  - Access ..... 29
- MIN ..... 358
- MINH (trace information) ..... 58
- Mini front panel
  - Hiding/restoring ..... 298
  - Key combination ..... 299
  - Using ..... 305
- Minimum ..... 230
  - Marker positioning ..... 230
  - Next ..... 230
- Minimum attenuation ..... 166
- MKR
  - Key ..... 222
- MKR →
  - Key ..... 226
- Mnemonics ..... 355
  - Optional ..... 357
- Monitor
  - External ..... 303
  - Settings ..... 303
- MultiView
  - Status display ..... 59
  - Tab ..... 81, 85
- N**
- Name
  - Limit lines ..... 240
- NAN ..... 358
- NAN (not a number)
  - Remote control ..... 362
- Navigation control ..... 45
- NCor (enhancement label) ..... 57
- Network
  - Automatic login ..... 405
  - Changing user passwords ..... 405
  - Configuration (dialog box) ..... 388
  - Configuring ..... 344, 397
  - Connecting the instrument ..... 398
  - Creating users ..... 404
  - DNS server ..... 400
  - Login ..... 404
  - Operating the instrument ..... 403
  - Setting up ..... 397
  - Settings ..... 386
  - Sharing directories ..... 406
- Next Minimum ..... 230
  - Marker positioning ..... 230
- Next Mode X
  - Softkey ..... 228
- Next Mode Y
  - Softkey ..... 229
- Next Peak ..... 230
  - Marker positioning ..... 230
- NINF ..... 358
- NO REF
  - Error ..... 62, 714
- Noise
  - Saving settings ..... 255
- NOR
  - External generator ..... 151
- Notch (channel bar) ..... 56
- NTransition ..... 367
- Numerator
  - Frequencies, external generator ..... 149, 155
- Numeric parameters ..... 67, 358
- Numeric values
  - Special ..... 358
- O**
- OCXO ..... 53
- Offset
  - Limit lines ..... 235
- On-screen keyboard ..... 65, 67
- Online help
  - Working with ..... 76
- Online keyboard ..... 43
- Operating mode
  - Presetting ..... 327
- Operating system ..... 25
  - Login ..... 26
  - service packs ..... 26
- Operating temperature ..... 293
- Operation complete
  - Remote ..... 419
- Options
  - Identification (remote) ..... 419
  - Information ..... 323
  - Installing ..... 323, 324, 325
  - Secure user mode (K33) ..... 38, 249
- Orientation
  - Screenshot ..... 276
- Out (channel bar) ..... 56
- Output
  - Buffer ..... 366
  - Configuration (softkey) ..... 156
  - External reference ..... 322
  - Probe power ..... 160
  - Settings ..... 156
  - Trigger ..... 160, 161
- OVEN
  - Error ..... 62, 714
- OVEN (status display) ..... 62, 714
- Overlapping commands ..... 363
  - Preventing ..... 364
- Overloading
  - External generator ..... 152
- P**
- Paint
  - Accessing ..... 29
- Parallel poll register enable
  - Remote ..... 420
- Parameters
  - Block data ..... 360
  - Boolean ..... 359
  - Entering ..... 67
  - Numeric values ..... 358
  - SCPI ..... 357
  - Special numeric values ..... 358

- String ..... 359
  - Text ..... 359
  - Password
    - Secure user mode ..... 328
  - Passwords
    - Changing ..... 405
    - Secure user mode ..... 39, 250
    - Service functions ..... 334
  - Peak excursion ..... 117, 120, 221, 227
  - Peak list ..... 222
    - Peak excursion ..... 227
  - Peak search ..... 107, 117, 220
    - Area (spectrograms) ..... 229
    - Automatic ..... 222
    - Deactivating limits ..... 228
    - Excursion ..... 221
    - Key ..... 230
    - Limits ..... 221, 227
    - List ..... 222
    - Mode ..... 227, 228
    - Mode (spectrograms) ..... 229
    - Threshold ..... 228
    - Type (spectrograms) ..... 229
  - Peaks
    - Marker positioning ..... 230
    - Next ..... 230
    - Softkey ..... 230
  - Persistence spectrum
    - Spectrogram ..... 201
  - Ping ..... 403
  - PK (trace information) ..... 58
  - Ports
    - User ..... 482
  - Position
    - Limit line values ..... 242
  - Power key ..... 43
  - Power supply
    - Connector ..... 50
  - PPC ..... 352
  - PPE register ..... 366, 370
  - PPU ..... 352
  - Preamp (channel bar) ..... 56
  - Preamplifier ..... 116
  - Preselector ..... 143
  - Preset
    - channel settings ..... 249
    - Key ..... 248
    - Recalling settings ..... 261
  - Presetting
    - Channels ..... 140
  - Pretrigger ..... 180
  - Print Screen
    - Softkey ..... 273
  - Printer
    - Selecting ..... 275
  - Printer configuration
    - see user Manual ..... 19
  - Printers
    - Installing ..... 275
  - Printing
    - Colors ..... 299, 301, 303
    - Medium ..... 275
    - Screenshots ..... 273, 278
  - Probe power ..... 44
  - Probe power supply ..... 160
  - Product IDs ..... 353
  - Programming examples
    - Sequencer ..... 471
    - Service request ..... 669
    - Statistics ..... 564, 566
  - Protocol
    - VXI ..... 347
  - PS (channel bar) ..... 56
  - PSA emulation ..... 704
  - PSA89600
    - Wideband ..... 392
  - PTRansition ..... 367
  - PXA emulation ..... 708
- ## Q
- Queries ..... 354, 362
    - Status ..... 381
  - Question mark ..... 360, 362
  - Quick Config
    - Traces ..... 203
  - Quick recall
    - Settings ..... 252
  - Quick save
    - Secure user mode ..... 253, 254
    - Settings ..... 252
  - Quotation mark ..... 360
- ## R
- R&S FSP
    - Emulating ..... 391
    - Emulating (remote) ..... 653
  - R&S FSQ
    - Emulating ..... 391
    - Emulating (remote) ..... 653
  - R&S FSU
    - Emulating ..... 391
    - Emulating (remote) ..... 653
  - R&S FSV
    - Emulating ..... 391
    - Emulating (remote) ..... 653
  - R&S SMA
    - External generator ..... 147
  - R&S SMW
    - External generator ..... 147
  - R&S Support ..... 330
  - Rackmounting ..... 23
  - RBW ..... 96, 97, 114
    - IF analysis ..... 172
  - Ready for trigger
    - Status register ..... 371
  - Real-Time spectrum
    - Application ..... 83
  - Rebooting
    - Remote control ..... 610
  - Recalling
    - Settings ..... 251, 252, 255, 258
    - Settings for preset ..... 261
    - Softkey ..... 255
  - Receive frequency ..... 168
  - Receiver
    - Application ..... 82
  - Receiver frequency ..... 171
  - Recommendations
    - Remote control programming ..... 382
  - Redo ..... 45, 46

- REF INPUT
    - Connector ..... 53
  - Reference
    - External ..... 320
    - Frequency ..... 320
    - Internal ..... 320
    - Softkey ..... 320
  - Reference frequency
    - Default ..... 322
    - External generator ..... 147, 153
    - Input ..... 320
    - Output ..... 322
  - Reference marker ..... 224
  - Reflection measurement
    - External generator ..... 146
  - Registers ..... 366
  - Relay Cycle Counter ..... 335
  - Release notes ..... 17
  - Remote control ..... 79
    - Blocked ..... 716
    - Errors ..... 716
    - Ignored commands ..... 382
    - Interfaces ..... 344
    - LXI settings ..... 393
    - Protocols ..... 344
    - Sequential commands ..... 716
  - Remote Desktop ..... 397, 408
    - Client ..... 410
    - Ending session ..... 411
    - Setting up a connection ..... 411
    - Setting up controller ..... 410
    - Setting up instrument ..... 409
  - Remote display
    - Update ..... 389
  - Remote operation
    - Configuring ..... 344
    - Deactivating the instrument ..... 413
    - GPIB address ..... 403
    - GPIB settings ..... 388
    - see also Remote control ..... 344
    - Setting up ..... 397
    - Settings ..... 386
    - Starting ..... 414
    - Stopping ..... 415
  - Removable hard drive ..... 50
  - Report ..... 282
  - Reset values
    - Remote ..... 420
  - Restoring
    - Channel settings ..... 140
  - Restricted operation
    - Secure user mode ..... 39, 250
  - Restrictions
    - Storage space ..... 38, 250
  - Result displays
    - Programming example ..... 511
  - Result frequency
    - External generator ..... 156
  - Results
    - Data format (remote) ..... 514, 515, 568
    - Displaying ..... 68
    - Exporting ..... 204
    - Managing ..... 248
  - Reverse sweep
    - External generator ..... 150, 155
  - Revision string
    - GPIB ..... 393, 655
    - GPIB (remote control) ..... 655
    - Resetting ..... 393
  - RF attenuation ..... 116
  - RF input ..... 117
  - RF OVLD
    - Error ..... 62, 714
    - External generator ..... 151
  - RF OVLD (status display) ..... 62, 714
  - RF switch ..... 311
  - RM (trace information) ..... 58
  - Rotary knob ..... 45, 46
- ## S
- SA (trace information) ..... 58
  - Safety instructions ..... 17
  - Save/Recall Mode
    - Settings ..... 257
  - Savesets
    - Settings ..... 253
  - Saving
    - Classified data ..... 38, 249
    - Data types ..... 254
    - Functions ..... 255
    - Instrument settings ..... 259
    - Limit lines ..... 242
    - Screenshots ..... 278
    - Settings ..... 255
    - Softkey ..... 255
  - Scalar reflection measurement
    - External generator ..... 146
  - Scaling ..... 168
  - Scan ..... 109
    - Bandwidth ..... 96, 114
    - Detector ..... 127
    - Measurement time ..... 95, 115
  - Scan range ..... 112
  - Scan table ..... 113
  - SCPI
    - Parameters ..... 357
    - Syntax ..... 355
    - version ..... 353
  - SCPI confirmed commands ..... 354
  - Screen
    - See Touchscreen ..... 300
  - Screenshots
    - Printing ..... 273, 278
    - Saving ..... 273, 278
  - SDC ..... 352
  - Search limits
    - Deactivating ..... 228
  - Search Limits
    - Activating ..... 227
  - Searching
    - In help ..... 77
  - Secure user mode
    - Activating ..... 328
    - Activating/deactivating ..... 39, 250
    - Background information ..... 37, 249
    - Instrument settings ..... 252
    - Login ..... 27
    - Passwords ..... 39, 250
    - Quick save ..... 253, 254
    - Redirecting storage ..... 38, 249
    - Remote ..... 661

- Restricted operation ..... 39, 250
- Self-alignment ..... 292, 324, 326, 386, 387
- Self-alignment data ..... 38, 250
- Storage location ..... 255, 256, 258
- Transducer settings ..... 307
- SecureUser ..... 39, 250
- Select Frame
  - Softkey ..... 208
- Select Marker ..... 224
- Self-alignment ..... 291
  - Aborting ..... 292
  - Secure user mode ..... 38, 250, 292, 324, 326, 386, 387
  - Starting ..... 292
- Self-test
  - Performing ..... 293, 330
  - Remote ..... 421
  - Results ..... 330, 617
  - Settings ..... 330
  - Temperature ..... 293
- Sequencer ..... 56
  - Aborted ..... 292, 331
  - Aborting (remote) ..... 430
  - Activating (remote) ..... 431
  - Channels ..... 85
  - Example ..... 87
  - Mode ..... 86, 88
  - Mode (remote) ..... 431
  - Programming example ..... 471
  - RUN SINGLE ..... 87
  - Setting up ..... 88
  - Single Sweep ..... 87
  - Softkey ..... 88
  - State ..... 88
- Sequential commands ..... 363
  - Errors ..... 716
- Service functions ..... 329, 332, 333
  - Numeric mode ..... 334
  - Passwords ..... 334
  - Results ..... 334
- Service manual ..... 16
- Service packs ..... 26
- Service request (SRQ) ..... 344, 366, 369, 379
- Service request enable register (SRE) ..... 366, 369
  - Remote ..... 420
- Setting commands ..... 354
- Settings
  - filename ..... 256, 259
  - Loading ..... 259
  - Managing ..... 248
  - Recalling ..... 251, 252
  - Recalling; restrictions ..... 251
  - Saving ..... 255, 259
  - Storage location ..... 256, 258
  - Storing ..... 251, 252
- Setup files
  - External generator ..... 149, 153
- SGL (channel bar) ..... 56
- Shift x
  - Limit lines ..... 242
- Shift y
  - Limit lines ..... 242
- Shifting
  - Limit lines ..... 235
- Shutdown
  - Automatic ..... 293
- Signal tracking ..... 170, 173
  - Bandwidth ..... 170
  - Softkey ..... 170
  - State ..... 170
  - Threshold ..... 170
  - Trace ..... 170
- Single Sequencer
  - Softkey ..... 88
- Single zoom ..... 188
- SmartGrid
  - Activating ..... 72, 185
  - Arranging windows ..... 74, 187
  - Display ..... 70, 183
  - Evaluation bar ..... 73, 186
  - Features ..... 70, 183
  - Mode ..... 72, 185
  - Programming example ..... 511
- Soft front panels
  - Using ..... 304
- Softkey bar
  - Hiding/restoring ..... 296
- Softkeys
  - Clear All Messages (remote control) ..... 660
  - Clear Spectrogram ..... 209
  - Color Mapping ..... 209
  - Comment ..... 272
  - Continuous Sequencer ..... 88
  - Device ..... 272, 274, 276
  - Display Config ..... 182
  - Export ..... 261, 263
  - Export config ..... 262, 264
  - External ..... 179
  - Free Run ..... 179
  - History Depth ..... 208
  - Horizontal Line 1/2 ..... 232
  - I/Q Export ..... 262, 264
  - Import ..... 263
  - Install Printer ..... 275
  - Line Config ..... 237
  - Marker Config ..... 223, 225
  - Marker Search Area ..... 229
  - Marker Search Type ..... 229
  - Marker to Trace ..... 224
  - Min ..... 230
  - Next Min ..... 230
  - Next Mode X ..... 228
  - Next Mode Y ..... 229
  - Next Peak ..... 230
  - Outputs Config ..... 156
  - Peak ..... 230
  - Print Screen ..... 273
  - R&S Support ..... 330
  - Recall ..... 255
  - Recall File ..... 254, 257
  - Reference ..... 320
  - Save ..... 255
  - Save File ..... 257
  - Select Frame ..... 208
  - Select Marker ..... 224
  - Sequencer ..... 88
  - Signal Track ..... 170
  - Single Sequencer ..... 88
  - Spectrogram ..... 208
  - Startup Recall ..... 258
  - Startup Recall (On/Off) ..... 258
  - Status ..... 64
  - System Messages (remote control) ..... 660

Timestamp .....	209
Trigger Config .....	178
Vertical Line 1/2 .....	232
Source offset	
External generator .....	155
Source power	
External generator .....	154
Span	
IF analysis .....	172
SPD .....	352
SPE .....	352
Specifics for	
Configuration .....	141
Spectrograms	
Activating/Deactivating .....	208
Clearing .....	209
Color curve .....	201, 210, 215
Color mapping .....	200, 209, 213
Color scheme .....	200, 211
Configuring .....	213
Display .....	196
Displaying .....	212
History depth .....	208
Markers .....	199, 213
Removing .....	212
Scaling .....	199
Selecting frames .....	208
Settings .....	207
Softkey .....	208
Time frames .....	198
Timestamps .....	199, 209
Value range .....	200, 214
Spectrum	
Application .....	83
Split	
Window .....	75
Split screen mode .....	43
Splitters	
Window size .....	74
Squelch .....	159
SRE (service request enable register) .....	369
SRQ (service request) .....	369, 379
Start frequency .....	112, 172
Startup recall	
Remote .....	579
Startup Recall	
Softkey .....	258
Statistics	
Programming example .....	564, 566
Status	
Queries .....	381
Status bar	
Color coding .....	61, 713
Error messages .....	60, 713
Error messages, external generator .....	151
Hiding/restoring .....	296
Secure user mode .....	39, 250
Status byte	
Remote .....	418, 421
Status byte (STB) .....	369
Status byte register (STB) .....	366
Status display .....	59
Status registers .....	366
CONDition .....	367
ENABle .....	367
EVENT .....	367
model .....	367
NTRansition .....	367
parts .....	367
PTTransition .....	367
STATus:OPERation .....	371
STATus:QUESTionable .....	372
STATus:QUESTionable:ACPLimit .....	373
STATus:QUESTionable:EXTended .....	374
STATus:QUESTionable:EXTended:INFO .....	374
STATus:QUESTionable:FREquency .....	375
STATus:QUESTionable:LIMit .....	376
STATus:QUESTionable:LMARgin .....	376
STATus:QUESTionable:POWer .....	377
STATus:QUESTionable:TEMPerature .....	290, 617
STATus:QUESTionable:TIME .....	378
STATus:QUESTionable:TRANsducer .....	378
Status reporting system .....	365
Application .....	379
Common commands .....	417
Step (channel bar) .....	56
Stepsize	
Frequency .....	173
Stop frequency .....	112, 172
Storage location	
Data files .....	255
Secure user mode .....	255, 256, 258
Settings .....	256, 258
Storage settings	
File type .....	257
Storing	
Settings .....	251, 252
String in remote commands .....	359
Subnet Mask .....	388
Suffixes .....	356
Common .....	417
Support .....	80, 718
Information .....	329, 330
Suppressing	
File name dialog .....	275
Sweep points	
Logarithmic x-axis scaling .....	169
Sweep Repeat	
GPIB .....	392
GPIB (remote control) .....	656
Sweep status	
Status register .....	371
Sweeps	
Reverse, external generator .....	150
Switch matrix .....	311
SYNC TRIGGER	
Connector .....	51
Syntax elements	
SCPI .....	360
System	
Configuration .....	323
Messages .....	325
Preset operating mode .....	327
System keys .....	43
<b>T</b>	
<b>Tab</b> s	
All .....	69
MultiTab .....	55
MultiView .....	81
Switching .....	55
<b>Task bar</b>	
Accessing .....	29



- TCP/IP
    - Address, External generator ..... 153
    - External generator ..... 153
  - TDF (channel bar) ..... 57
  - Temperature
    - Check ..... 290
    - Check (remote) ..... 617
    - Frontend ..... 290
    - Frontend (remote) ..... 617
    - Frontend, status bit ..... 290
    - Self-alignment ..... 290
    - Self-alignment (remote) ..... 617
  - Template ..... 282
  - Test report ..... 282
  - Text paramters in remote commands ..... 359
  - Theme
    - Display ..... 299, 300
  - Threshold
    - Limit lines ..... 234, 241
    - Peak search ..... 228
    - Signal tracking ..... 170
  - Time
    - Format ..... 295
    - Hiding/restoring ..... 297
    - Instrument setting ..... 295
    - Setting ..... 37
  - Time frames
    - Navigating ..... 199
    - Selecting ..... 208
    - Spectrograms ..... 198
  - Timestamps
    - Softkey (Spectrogram) ..... 209
    - Spectrograms ..... 199, 209
  - Toolbar
    - Hiding/restoring ..... 296
    - Overview ..... 63
  - touchscreen
    - Alignment ..... 290, 293
  - Touchscreen
    - Alignment ..... 291, 294
    - Colors ..... 299, 300
    - De-/Activating ..... 295
    - Displayed items ..... 296
    - Overview ..... 41
    - Settings ..... 295
    - Theme ..... 300
  - Trace information ..... 57
    - Detector type ..... 58
    - Trace number ..... 57
    - Window title bar ..... 57
  - Traces
    - Copying ..... 205
    - Copying (remote control) ..... 515
    - Export format ..... 204
    - Exporting ..... 204, 205, 211
    - Mode ..... 126
    - Saving ..... 255
    - Settings, predefined ..... 203
  - Traces to be Checked
    - Limit lines ..... 238
  - Tracking
    - see External generator ..... 154
  - Tracking bandwidth ..... 170
  - Tracking generator
    - see External generator ..... 144
  - Tracking threshold ..... 170
  - Transducer break ..... 306
  - Transducer factors ..... 306
  - Transducer set ..... 306
  - Transducers ..... 307
    - Checking ..... 317
    - Compatible ..... 317
    - Configuring ..... 316
    - Copying ..... 317
    - Creating ..... 318
    - Deleting ..... 318
    - Editing ..... 317
    - Recalling ..... 252
    - Saving ..... 252, 255
    - Secure user mode ..... 307
    - Shifting ..... 318
  - Transmission measurement
    - External generator ..... 146
  - TRG (channel bar) ..... 57
  - Trigger
    - Configuration (Softkey) ..... 178
    - Event (remote) ..... 421
    - External, errors ..... 716
    - Input ..... 45
    - Level ..... 179
    - offset ..... 180
    - Offset ..... 175
    - Output ..... 45, 161
    - Slope ..... 180
    - Source ..... 179
    - Status register ..... 371
  - Trigger output ..... 160
  - Trigger source
    - External ..... 179
    - Free Run ..... 179
  - Troubleshooting
    - File name error ..... 579
    - Hardware ..... 334
    - Low frequencies ..... 717
    - Overload, external generator ..... 152
    - Remote control programs ..... 390, 716
    - Timeout for data capture ..... 717
    - Trace display ..... 717
  - TTL handshake
    - see TTL synchronization ..... 153
  - TTL synchronization
    - AUX control, external generator ..... 145
    - External generator ..... 145, 150, 153
  - Tuning range
    - External reference ..... 321
- ## U
- UNCAL
    - Error ..... 62, 714
  - UNCAL (status display) ..... 62, 714
  - Undo ..... 45, 46
  - Unit ..... 166
  - UP ..... 358
  - Update Path
    - Remote control ..... 660
  - Update rate
    - Display ..... 295
  - Updating
    - Firmware ..... 325
  - USB
    - Address ..... 352
    - Connector ..... 51
    - Interfaces ..... 352



- USB port ..... 43
- User ports
  - Remote control ..... 482
- Users
  - Network ..... 404
  - Password ..... 405
- V**
- Vendor ID
  - Rohde & Schwarz ..... 352
- Version information ..... 323
- Vertical Line 1/2
  - Softkeys ..... 232
- Vertical stroke ..... 360
- View filter
  - Limit lines ..... 239
- Virus protection ..... 26
- VISA ..... 345, 346
  - Libraries ..... 353
  - Resource string ..... 346, 353
- Visible
  - Limit lines ..... 238
- Volatile memory
  - Secure user mode ..... 38, 249
- Volume control ..... 44
- VXI protocol ..... 347
- W**
- Wait
  - Remote ..... 421
- Waiting for trigger
  - Status register ..... 371
- Warmup time ..... 293
- Web browser
  - Configuration interface ..... 401
- White papers ..... 17
- White space ..... 360
- Wideband
  - PSA89600 ..... 392
- Window title bar ..... 57
- Windows
  - Adding ..... 73, 186
  - Adding (remote) ..... 505
  - Arranging ..... 74, 187
  - Closing ..... 73, 186
  - Closing (remote) ..... 507, 510
  - Configuring ..... 141
  - Dialog boxes ..... 67
  - Layout (remote) ..... 508
  - Maximizing (remote) ..... 505
  - Querying (remote) ..... 506, 507
  - Replacing (remote) ..... 507
  - Size ..... 74
  - Splitting (remote) ..... 505
  - Types (remote) ..... 505
- WordPad
  - Accessing ..... 29
- WRONG\_FW
  - Error ..... 62, 289, 325, 714
- X**
- X-axis
  - Limit lines ..... 241
  - Scaling ..... 169
- X-Offset
  - Limit lines ..... 239
- X-value
  - Marker ..... 223
- Y**
- Y-axis
  - Limit lines ..... 241
- Y-Offset
  - Limit lines ..... 239
- Z**
- Zooming
  - Activating (remote) ..... 514
  - Area (remote) ..... 513
  - Deactivating ..... 188
  - Restoring original display ..... 188
  - Single mode ..... 188