

Torque flange

**T10FS**



<b>Content</b>	<b>Page</b>
<b>Safety instructions</b> .....	<b>5</b>
<b>1 Torque flange versions</b> .....	<b>8</b>
<b>2 Application</b> .....	<b>9</b>
<b>3 Structure and mode of operation</b> .....	<b>10</b>
<b>4 Mechanical installation</b> .....	<b>11</b>
4.1 Conditions on site .....	12
4.2 Mounting position .....	12
4.3 Installation possibilities .....	13
4.3.1 Installation without undoing the antenna ring (without speed measuring system) .....	13
4.3.2 Installation with subsequent stator mounting (without speed measuring system) .....	14
4.3.3 Installation example with couplings .....	15
4.3.4 Installation example with cardan shaft .....	15
4.4 Mounting the rotor .....	16
4.5 Installing the stator .....	18
4.6 Mounting the clamping part .....	20
4.7 Installing the slotted disc (speed measuring system) .....	22
4.8 Fitting the mounting elements (speed measuring system) .....	23
4.8.1 Fixing the mounting elements .....	24
4.8.2 Mounting the torque flange with the speed measuring system ...	24
4.9 Aligning the stator (speed measuring system) .....	26
<b>5 Electrical connection</b> .....	<b>28</b>
5.1 Shielding design .....	28
5.2 Option 2, code KF1 .....	29
5.2.1 Adaptation to the cable length .....	29
5.3 Option 2, code SF1/SU2 .....	31
5.4 Supply voltage .....	33
<b>6 Calibration</b> .....	<b>34</b>
6.1 Calibration Option2, code KF1 .....	34
6.2 Calibration Option2, code SF1/SU2 .....	34
<b>7 Settings</b> .....	<b>35</b>
7.1 Torque output signal, code KF1 .....	36
7.2 Torque output signal, code SF1/SU2 .....	36
7.3 Setting up the zero point .....	36
7.4 Functional testing .....	37
7.4.1 Power transmission .....	37
7.4.2 Alignment of the speed module .....	38
7.5 Setting the pulse count .....	39
7.6 Vibration suppression (hysteresis) .....	40
7.7 Shape of the rotation speed output signal .....	41
7.8 Type of rotation speed output signal .....	42

---

7.9	Reference pulse (option) .....	42
<b>8</b>	<b>Loading capacity</b> .....	<b>44</b>
8.1	Measuring dynamic torque .....	44
<b>9</b>	<b>Maintenance</b> .....	<b>46</b>
9.1	Speed module maintenance .....	46
<b>10</b>	<b>Dimensions</b> .....	<b>47</b>
10.1	Rotor dimensions .....	47
10.2	Dimensions stator .....	48
10.3	Mounting dimensions .....	49
<b>11</b>	<b>Order-No., accessories</b> .....	<b>50</b>
<b>12</b>	<b>Specifications</b> .....	<b>51</b>
<b>13</b>	<b>Supplementary technical information</b> .....	<b>57</b>
13.1	Output signals .....	57
13.1.1	Output MD: torque (plug 1) .....	57
13.1.2	Output N: rotation speed and rotation speed with reference pulse (plug 2) .....	58
13.1.3	Plug 2, double frequency, stat. direction of rotation signal .....	59
13.2	Run-out and concentric tolerances .....	60
13.3	Additional mechanical data .....	60
<b>14</b>	<b>Declaration of conformity</b> .....	<b>61</b>

## **Safety instructions**

### **Use in accordance with the regulations**

Torque flanges T10FS are used exclusively for torque and rotation speed measurement tasks and control and adjustment tasks directly connected thereto. Use for any additional purpose shall be deemed to be **not** in accordance with the regulations.

In the interests of safety, the transducer should only be operated as described in the Operating Manual. It is also essential to observe the appropriate legal and safety regulations for the application concerned during use. The same applies to the use of accessories.

The transducer is not a safety element within the meaning of its use as intended. Proper and safe operation of this transducer requires proper transportation, correct storage, assembly and mounting and careful operation.

### **General dangers of failing to follow the safety instructions**

The transducer corresponds to the state of the art and is fail-safe. The transducer can give rise to remaining dangers if it is inappropriately installed and operated by untrained personnel.

Everyone involved with the installation, commissioning, maintenance or repair of the transducer must have read and understood the Operating Manual and in particular the technical safety instructions.

### **Remaining dangers**

The scope of supply and performance of the transducer covers only a small area of torque measurement technique. In addition, equipment planners, installers and operators should plan, implement and respond to the safety engineering considerations of torque measurement technique in such a way as to minimise remaining dangers. Prevailing regulations must be complied with at all times. Reference must be made to remaining dangers connected with torque measurement technology.

In this Operating Manual remaining dangers are pointed out using the following symbols:



Symbol: **DANGER**

*Meaning:* **Maximum danger level**

Warns of an **imminently** dangerous situation in which failure to comply with safety requirements **will** result in death or serious physical injury.



Symbol: **WARNING**

*Meaning:* **Potentially dangerous situation**

Warns of a **potentially** dangerous situation in which failure to comply with safety requirements **can** result in death or serious physical injury.



Symbol: **CAUTION**

*Meaning:* **Dangerous situation**

Warns of a potentially dangerous situation in which failure to comply with safety requirements **could** result in damage to property or some form of physical injury.



Symbol: **NOTE**

Means that important information about the product or its handling is being given.



Symbol:

*Meaning:* CE mark

The CE mark enables the manufacturer to guarantee that the product complies with the requirements of the relevant EC directives (see Declaration of conformity at the end of this operating manual).

## **Conversions and modifications**

The transducer must not be modified from the design or safety engineering point of view except with our express agreement. Any modification shall exclude all liability on our part for any damage resulting therefrom.

## **Qualified personnel**

The transducer must only to be installed and used by qualified personnel, strictly in accordance with the specifications and with safety requirements and regulations. It is also essential to observe the appropriate legal and safety regulations for the application concerned during use. The same applies to the use of accessories.

Qualified personnel means persons entrusted with the installation, fitting, commissioning and operation of the product who possess the appropriate qualifications for their function.

## **Prevention of accidents**

According to the prevailing regulation to prevent accidents a cover has to be fitted after the mounting of the torque flange T10FS as follows:

- The cover or cladding must not be free to rotate.
- the cover shall avoid any danger of squeezing and provide protection against parts that might come loose
- Covers and cladding must be positioned at a suitable distance or so arranged that it prevents access to any moving parts within.
- Covers and cladding must also be attached if the moving parts of the torque flange are installed outside peoples' movement and operating range.

The only permitted exceptions to the above requirements are if the various parts and assemblies of the machine are already fully protected by the design of the machine or by existing safety precautions.

## **Warranty**

In the case of complaints, a warranty can only be given if the torque flange is returned in the original packaging.

## 1 Torque flange versions

In the case of option 2 "electrical configuration", torque flange T10FS exists in versions KF1, SF1 and SU2. The difference between these versions lies in the electrical inputs and outputs on the stator, the rotors are the same for all the versions of a measuring range. Alternatively, versions SF1 and SU2 can be equipped with a speed measuring system (with or without a reference pulse).

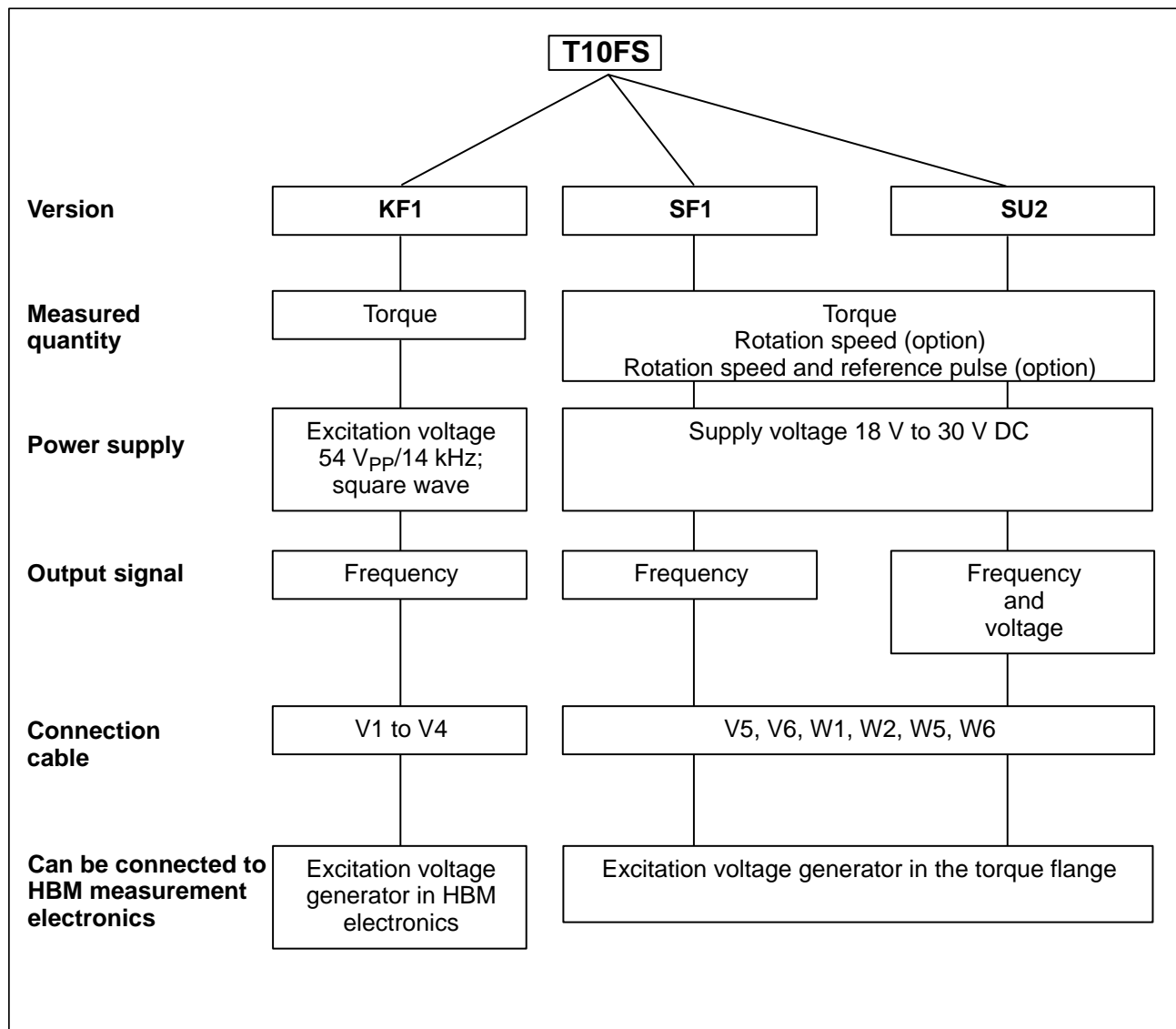

Fig. 1.1: T10FS versions

You can find out which version you have from the stator identification plate. The version is specified in the "T10FS-..." number there.

Example: T10FS-001R-**SU2**-S-0-V1-Y (see also Page 50).



## 2 Application

T10FS torque flanges record static and dynamic torques on fixed or rotating shafts and establish the rotation speed whilst indicating the direction of rotation. A reference pulse can also be output, as well as the rotation speed. Test beds can be extremely compact because of the short construction of the gauging flanges. They offer a very wide range of applications.

In addition to conventional test-rig applications (motor, roller and gear test-rigs) new solutions for torque measurements partly integrated into the machines are possible. Here, you benefit from the T10FS torque flanges' special characteristics:

- Low rotor weights
- Low mass moments of inertia
- Small outside diameters
- No bearings, no slip-rings

Due to their construction without bearings and the non-contact excitation-voltage and measurement transmission, the torque flanges are maintenance-free. This means that effects due to friction or the heating of bearings simply do not arise.

The torque flanges are supplied for nominal (rated) torques from 500 N·m up to 10 kN·m. Depending on the nominal (rated) torque, maximum speeds of up to 22 000 min<sup>-1</sup> are permissible.

The T10FS torque flanges are protected from electromagnetic interferences. They have been tested with regard to EMC according to the relevant European standards, and carry the CE mark.

### 3 Structure and mode of operation

The torque flanges consist of two separate parts: the rotor and the stator. The rotor comprises the measuring body and the signal transmission elements. Strain gauges (S.G.) have been mounted on the measuring body. The rotor electronics for excitation-voltage and measuring-signal transmission is located centrally in the flange. The transmitter coils for the non-contact transmission of excitation voltage and measuring signal are located on the measuring body's outer circumference. The signals are transmitted and received by a divisible antenna ring. The antenna ring is mounted on a housing that includes the electronic system for voltage adaptation and signal conditioning.

The connector for the torque signal, the voltage supply and the speed signal (option) are located on the stator. The antenna ring should be mounted concentrically around the rotor (see chapter 4).

In the case of option2 (speed measuring system), code L, the speed sensor is mounted on the stator, the customer attaches the associated slotted disc on the rotor. In the case of code H, the slotted disc is already mounted on the rotor.

Rotation speed measurement is made visually in accordance with the principle of infrared transmitted light barriers. The reference pulse is generated by a magnet in the slotted disc and a magneto-resistive sensor.

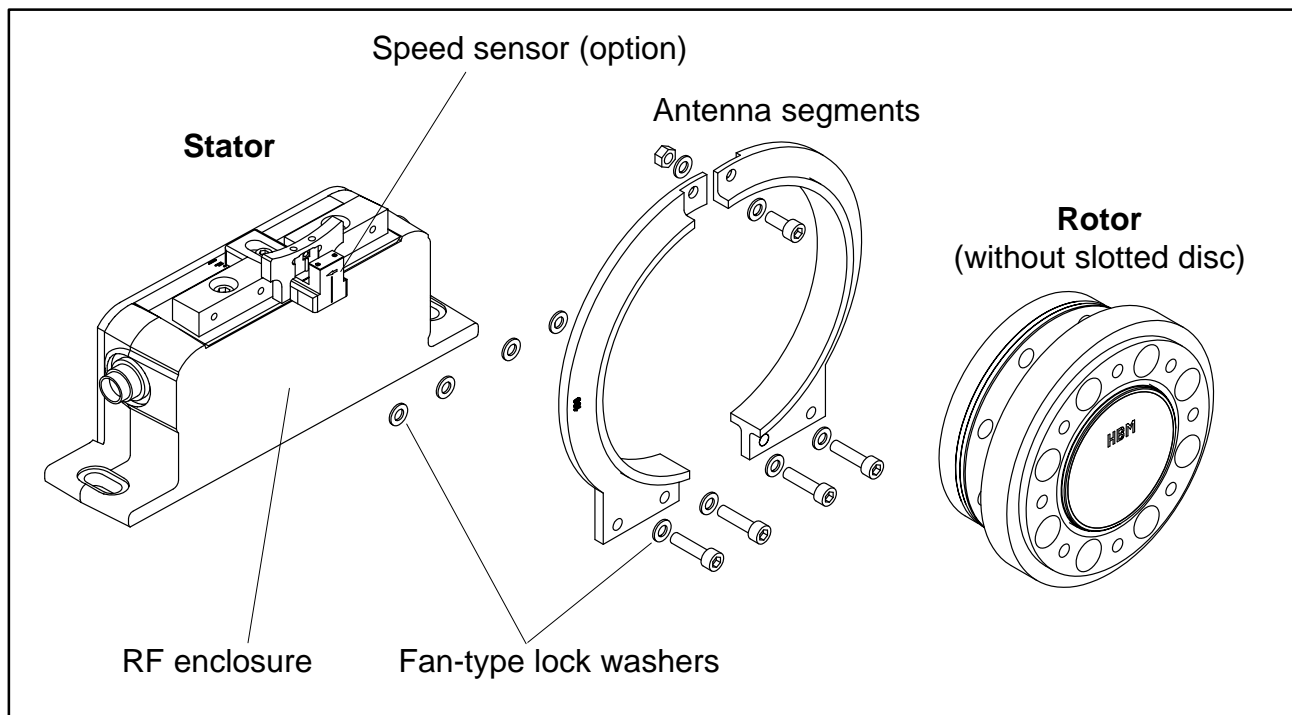

**Fig. 3.1:** Mechanical structure, explosive representation

## 4 Mechanical installation



### WARNING

Handle the torque flange carefully. The transducer might suffer permanent damage from mechanical shock (dropping), chemical effects (e.g. acids, solvents) or thermal effects (hot air, steam).

With alternating loads, you should use a screw locking device (medium) to glue the rotor connection-screws into the counter thread to exclude a pretension loss due to screw slackening.

An appropriate shaft flange enables the T10FS torque flanges to be mounted directly. It is also possible to mount a cardan shaft or relevant compensating element directly on the rotor (using an intermediate flange when required). Under no circumstances must the permissible limits specified for bending moments, transverse and longitudinal forces be exceeded. Due to the T10FS torque flanges' high torsional stiffness, dynamic changes on the shaft run are minimized.



### CAUTION

Do in any case check the effect on critical speeds and natural torsional vibrations to avoid an overloading of the gauging flanges due to resonance step-up.



### NOTE

For regular operation do in any case observe the mounting dimensions (see page 49).



### NOTE

Even if the transducer has been mounted correctly, the zero point balanced at the factory might be offset by about  $\pm 150$  Hz. If this value has been exceeded, we recommend to examine the mounting situation. If the remaining zero offset upon dismounting exceeds  $\pm 50$  Hz, please send the transducer to our Darmstadt plant for examination.

## 4.1 Conditions on site

The T10FS torque flanges are protected to IP54 according to EN 60529. They must be protected against coarse dirt particles, dust, oil, solvents and humidity. During operation, the prevailing safety regulations for the security of personnel must be observed (see "Safety instructions").

The output- and zero signal of the T10FS torque flange are compensated for the effects of temperature variations between wide limits (see specifications on page 51). This compensation is carried out at static temperatures. This guarantees that the circumstances can be reproduced and the properties of the transducer can be reconstructed at any time.

If there are no static temperature ratios, for example, because of the temperature differences between the measuring body and the flange, the values given in the specifications can be exceeded. Then for accurate measurements, static temperature ratios must be obtained by cooling or heating depending on the application. Alternatively, temperature decoupling must be checked, e.g. by heat radiating elements such as laminated couplings.

## 4.2 Mounting position

The gauging flange can be mounted in any position. With clockwise torque, the output frequency is 10 kHz to 15 kHz. With HBM amplifiers or with the "Voltage output" option, a positive output signal (0 V...+10 V) is present.

In the case of the speed measuring system, an arrow is attached to the head of the sensor to clearly determine the direction of rotation. If the gauging flange moves in the direction of the arrow, the connected HBM measuring amplifiers give off a positive output signal (0 V...+10 V).

### 4.3 Installation possibilities

On principle, there are two possibilities for torque flange mounting: with antenna ring complete or disassembled. We recommend to proceed as described in chapter 4.3.1. If mounting in accordance with 4.3.1 is not possible, (e.g. in the case of a subsequent stator replacement or mounting with the speed measuring system), you will have to undo the antenna ring. It is essential in this case to comply with the notes on assembling the antenna segments (see "Installing the stator" and "Installing the slotted disc").

#### 4.3.1 Installation without undoing the antenna ring (without speed measuring system)

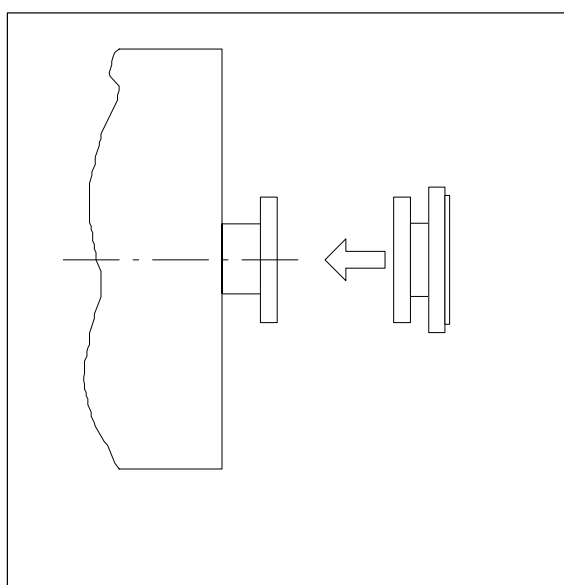

1. Install rotor

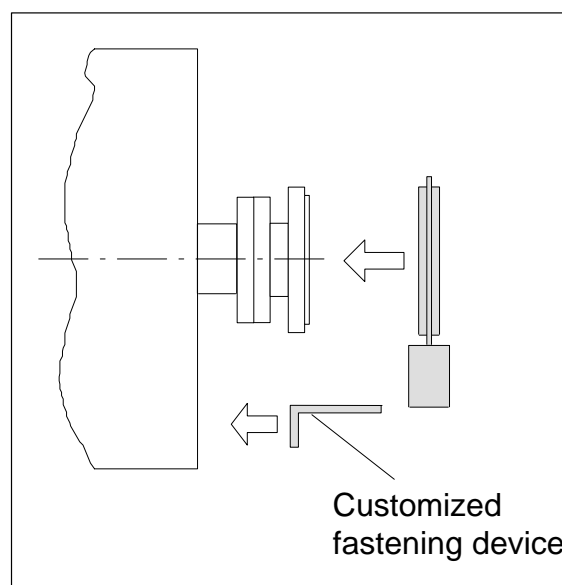

2. Install stator

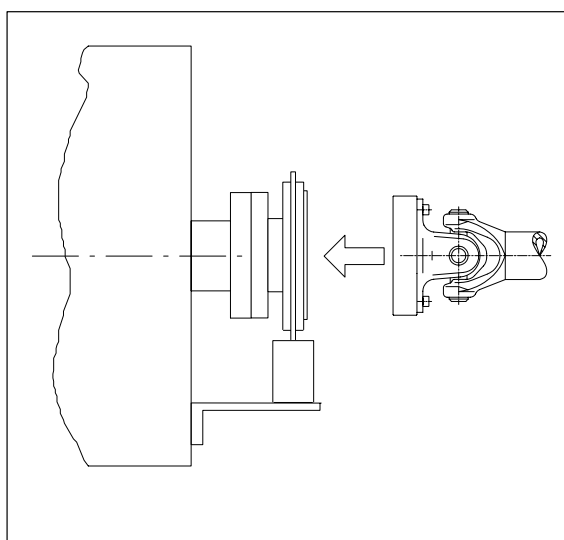

3. Finish installation of shaft run

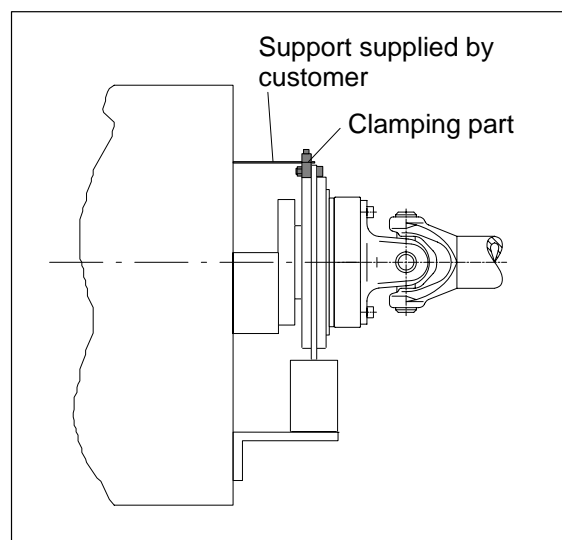

4. Mount the clamping part where required.

### 4.3.2 Installation with subsequent stator mounting (without speed measuring system)

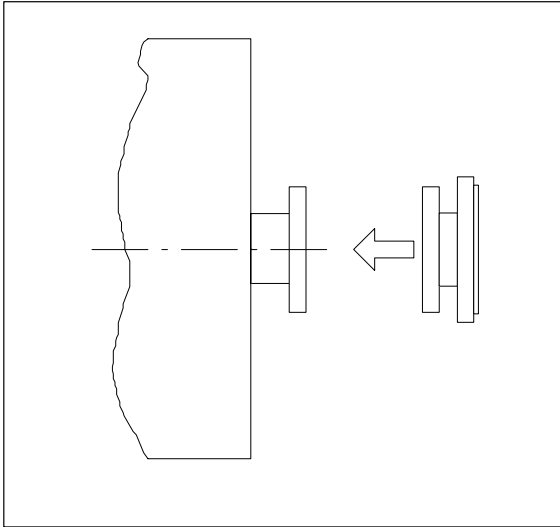

1. Install rotor

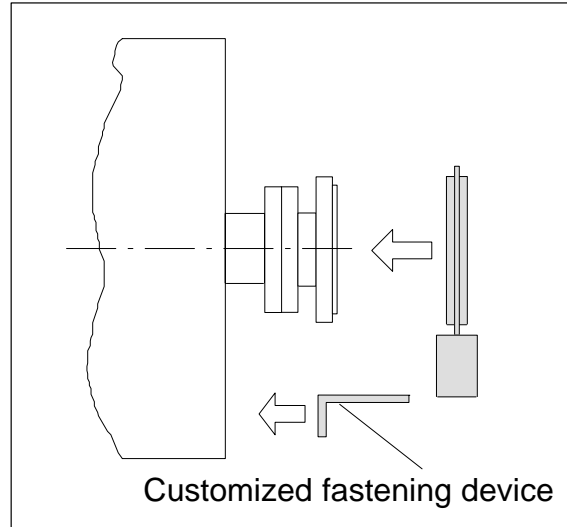

2. Install shaft run



3. Remove one antenna segment

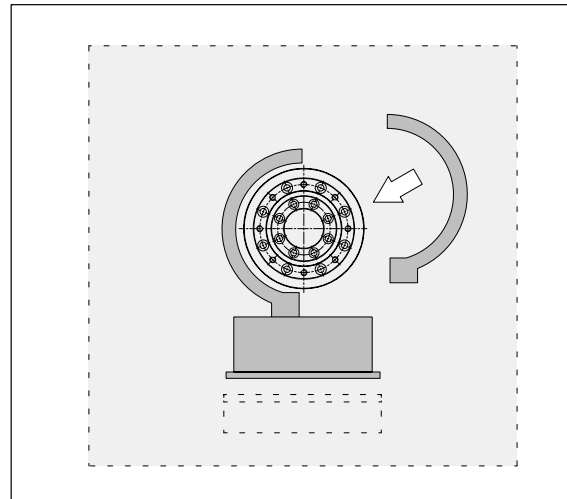

4. Install antenna segment around shaft run

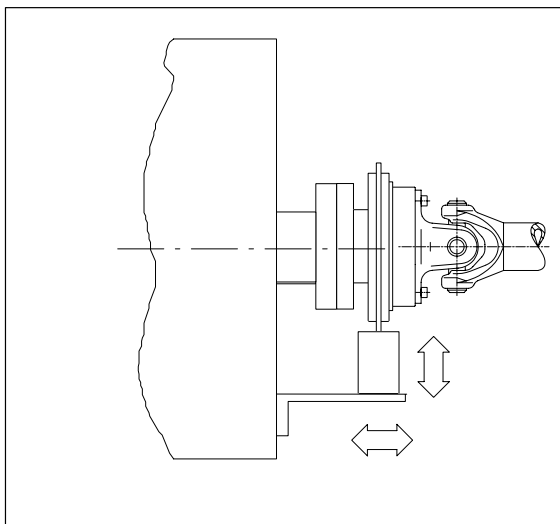

5. Align stator and finish installation

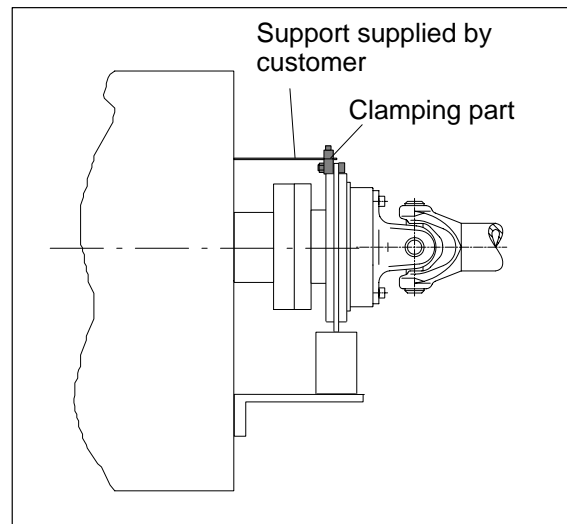

6. Mount the clamping part where required.

### 4.3.3 Installation example with couplings

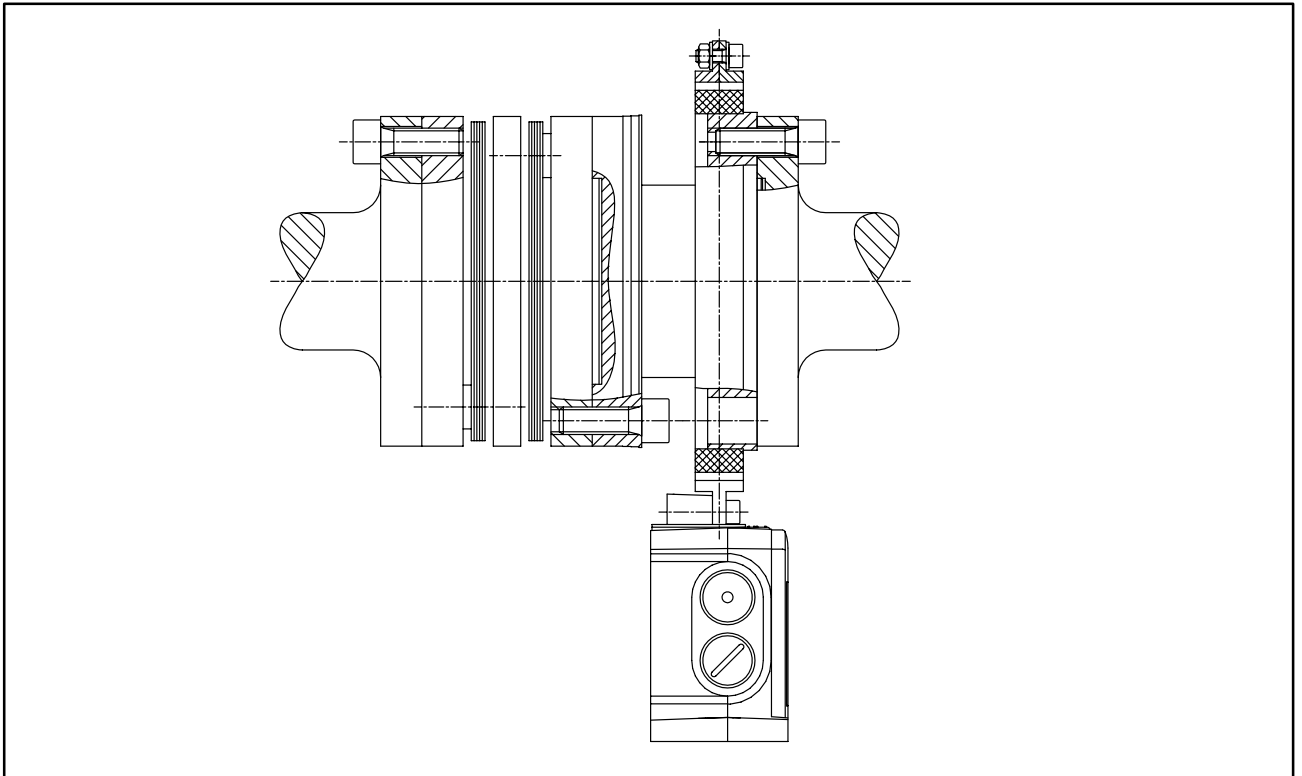

**Fig. 4.1:** Installation example with coupling

### 4.3.4 Installation example with cardan shaft

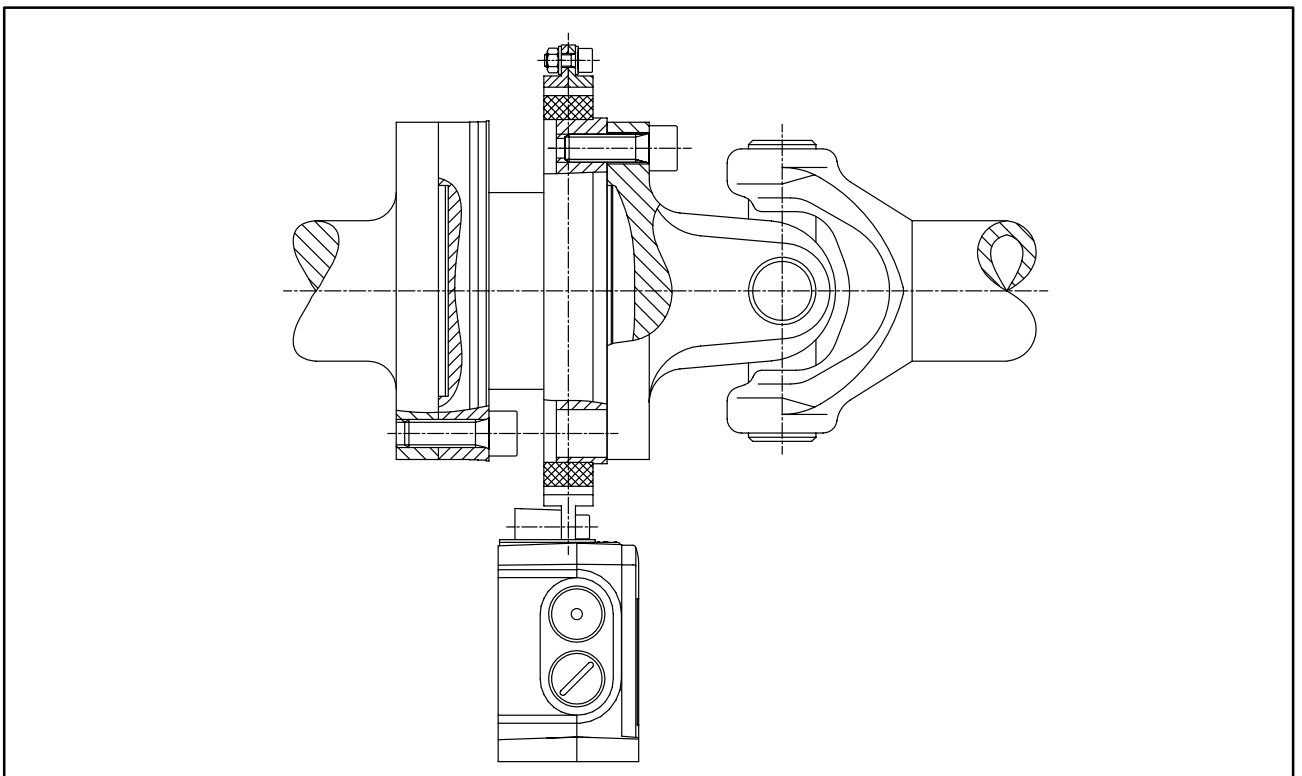

**Fig. 4.2:** Installation example with cardan shaft

## 4.4 Mounting the rotor

Additional installation notes for the speed measuring system can be found in Chapter 4.7, Page 22.



### NOTE

In general, the rotor identification plate is no longer visible after mounting. This is why we include with the rotor additional stickers with the important ratings, which you can attach to the stator or any other relevant test-bench components. You can then refer to them whenever there is anything you wish to know, such as the calibration signal. To enable the data to be assigned unequivocally, an ID number and the measuring range have been engraved on the rotor and are visible from outside (see Fig. 4.1).

1. Prior to installation, clean the gauging flange's and counter flanges' plane surfaces. For safe torque transfer, the surfaces must be clean and free from grease. Use a piece of cloth or paper soaked with a solvent. Make sure that no solvent drips into the gauging flange's interior and that the transmitter coils do not suffer damage.

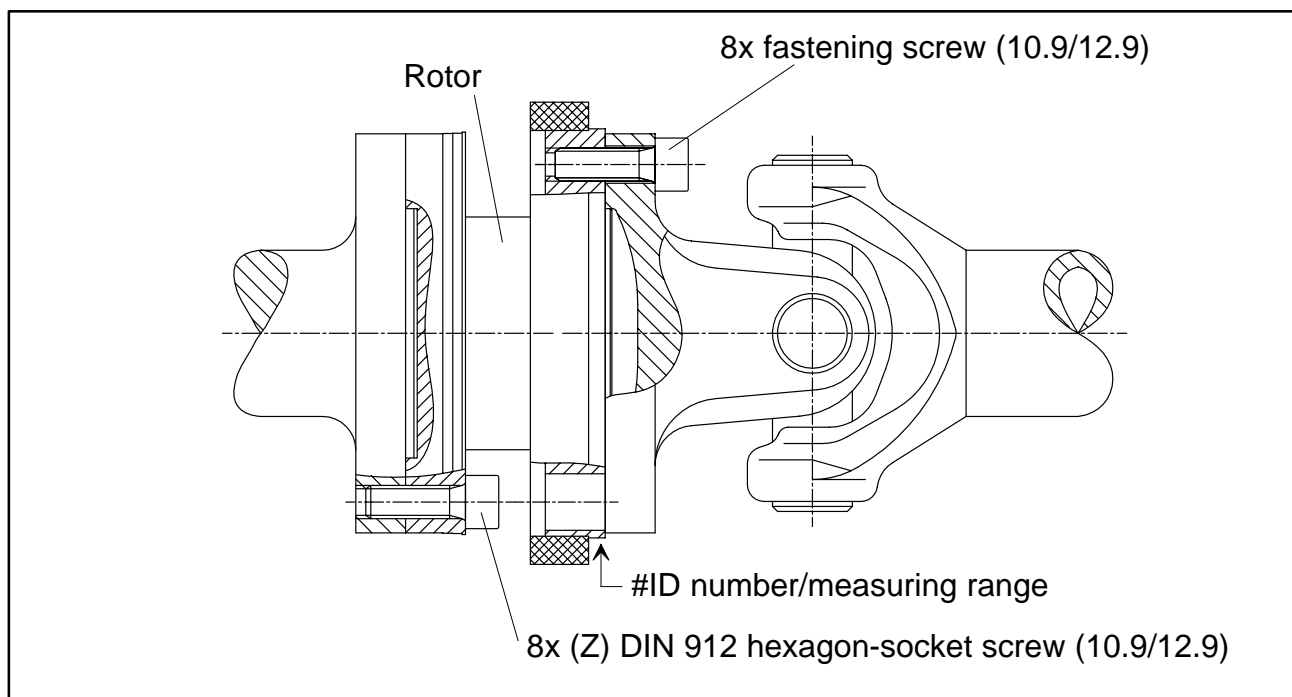

**Fig. 4.1:** Screwed joint of the rotor



2. Use eight **DIN912 hexagon-socket screws, property class 10.9 (measuring range 3 kN·m: 12.9)**, of the appropriate length (depending on the connection geometry) to screw-fasten the rotor.

We recommend fillister-head screws DIN 912 or similar, blackened, smooth-headed, permitted size and shape variance in accordance with DIN ISO 4759, Part 1, product class A.



### WARNING

**With alternating load: Use a screw locking device (e.g. LOCTITE no. 242) to glue the screws into the counter thread to exclude a pretension loss due to screw slackening.**

3. Fasten all screws with the specified tightening torque (Table 4.1).
4. For further mounting of the shaft run, there are eight threaded bores on the rotor. Also use screws of property class 10.9 (or 12.9) and fasten with the tightening torque specified in Table 4.1.



### CAUTION

**With alternating loads, use screw locking device to glue into place the connection screws. Guard against contamination from varnish fragments.**

Nominal (rated) torque (N·m)	Fastening screws (Z) <sup>1)</sup>	Fastening screws Resistance class	Prescribed tightening torque (N·m)
500	M10	10.9	67
1 k	M10		67
2 k	M12		115
3 k	M12	12.9	135
5 k	M14		220
10 k	M16		340

**Table 4.1:** Fastening screws

<sup>1)</sup>DIN 912 black/oiled/ $\mu_{tot}=0.125$

## 4.5 Installing the stator

On delivery, the stator has already been installed and is ready for operation. The antenna segments can be separated from the stator, for example, for maintenance or to facilitate stator mounting. To stop you modifying the centre alignment of the segment rings opposite the base of the stator, we recommend that you separate only one antenna segment from the stator. If your application does not require stator disassembly, proceed as described in sections 2., 6., 7. and 8.

### Version with speed measuring system

As the speed sensor includes the slotted disc, it is not possible to move the stator axially over the pre-assembled rotor. In this case, you should also comply with Chapter 4.7.

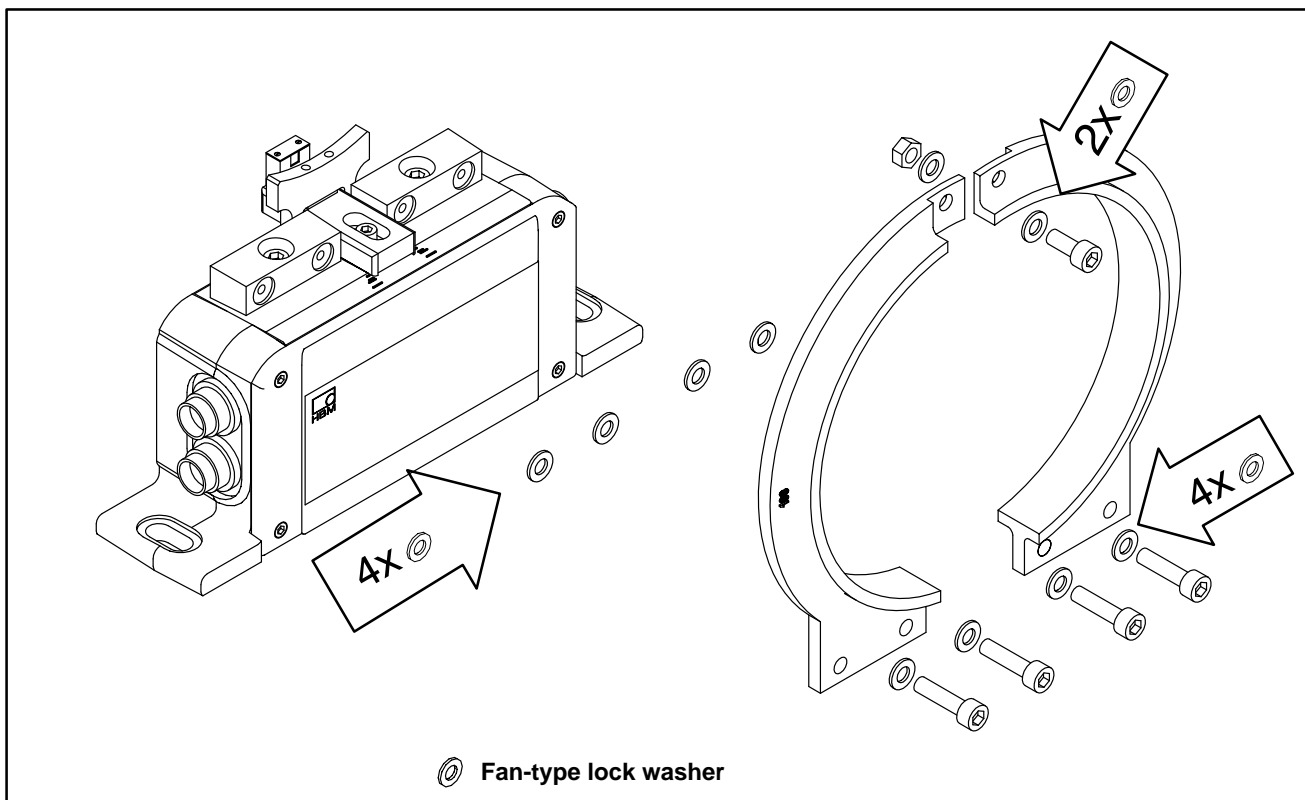

**Fig. 4.2:** Screwed joints of the antenna segments

1. Slacken and remove the screwed joints (M6) on one antenna segment. Make sure that the fan-type lock washers are not lost
2. Use an appropriate foundation plate to install the stator housing in the shaft run such that there is sufficient possibility for horizontal and vertical adjustments. Do not yet fasten the screws.

3. Now mount the antenna segment removed under point 1. back on the stator with two hexagon-socket screws and the fan-type lock washers. Make sure that none of the fan-type lock washers necessary for a defined contact resistance are missing (see Fig. 4.2). Do not yet fasten the screws.
4. Install the two antenna segments' upper connection screw such that the antenna ring is closed. Also pay attention to the fan-type lock washers.
5. Now, fasten all antenna-segment screw fastenings with a starting torque of 5 N·m.
6. Align antenna and rotor such that the antenna encloses the rotor coaxially. Please observe the permissible alignment tolerances specified in the specifications.
7. Fasten the stator-housing screwed joints.
8. Make sure that the opening in the lower antenna-segment section is free from electroconductive foreign substances.



### CAUTION

**To make sure that they function perfectly, the fan-type lock washers (A5,1–FST DIN 6798 ZN/galvanised) must be replaced after the screwed joint of the antenna has been detached three times.**

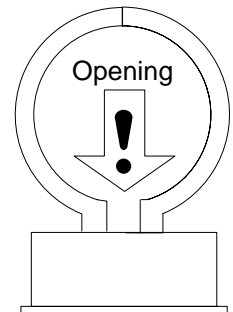

## 4.6 Mounting the clamping part

Depending on the operating conditions, the antenna ring may be excited to vibrate. This effect is dependent on

- the speed,
- the antenna diameter (depends in turn on the measuring range),
- the construction of the machine foundations.

To avoid vibrations, a clamping part is enclosed with the torque flange enabling the antenna ring to be supported.

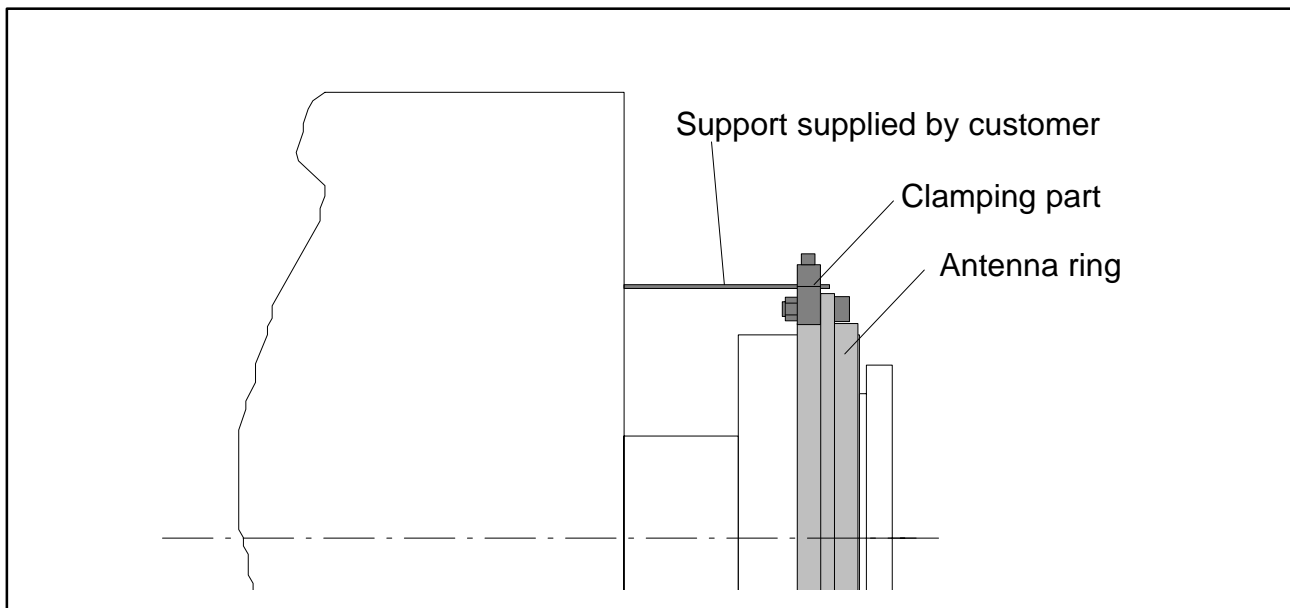

**Fig. 4.3:** Supporting the antenna ring

### Assembly sequence

1. Loosen and remove the upper antenna segment screws.
2. Fasten the clamping part with the enclosed screws as shown in Fig. 4.4. It is essential to use the new fan-type locking washers.
3. Clamp a suitable supporting element (we recommend a threaded rod of  $\varnothing$  3 mm to 6 mm diameter) between the upper and lower parts of the clamping part and tighten the clamping screws.

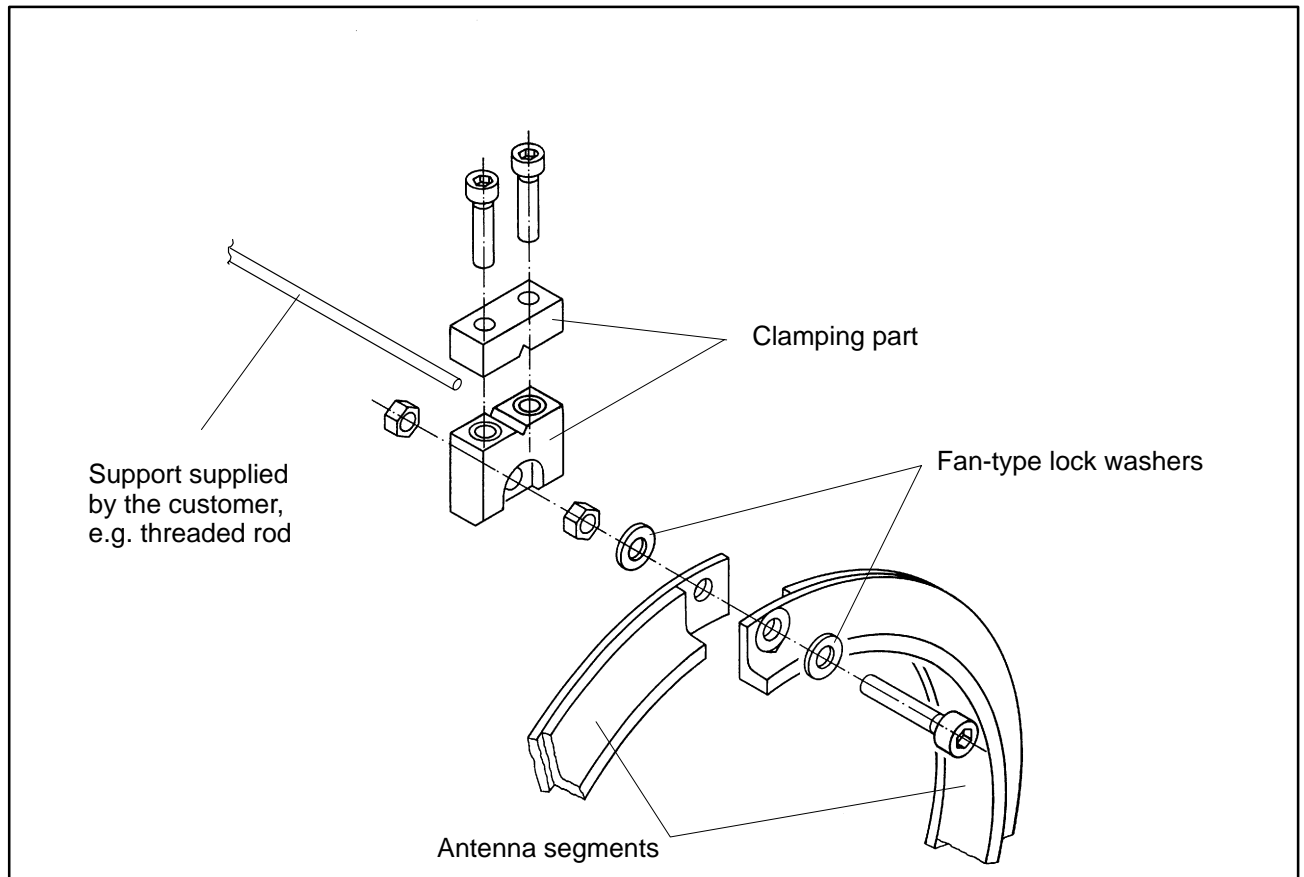
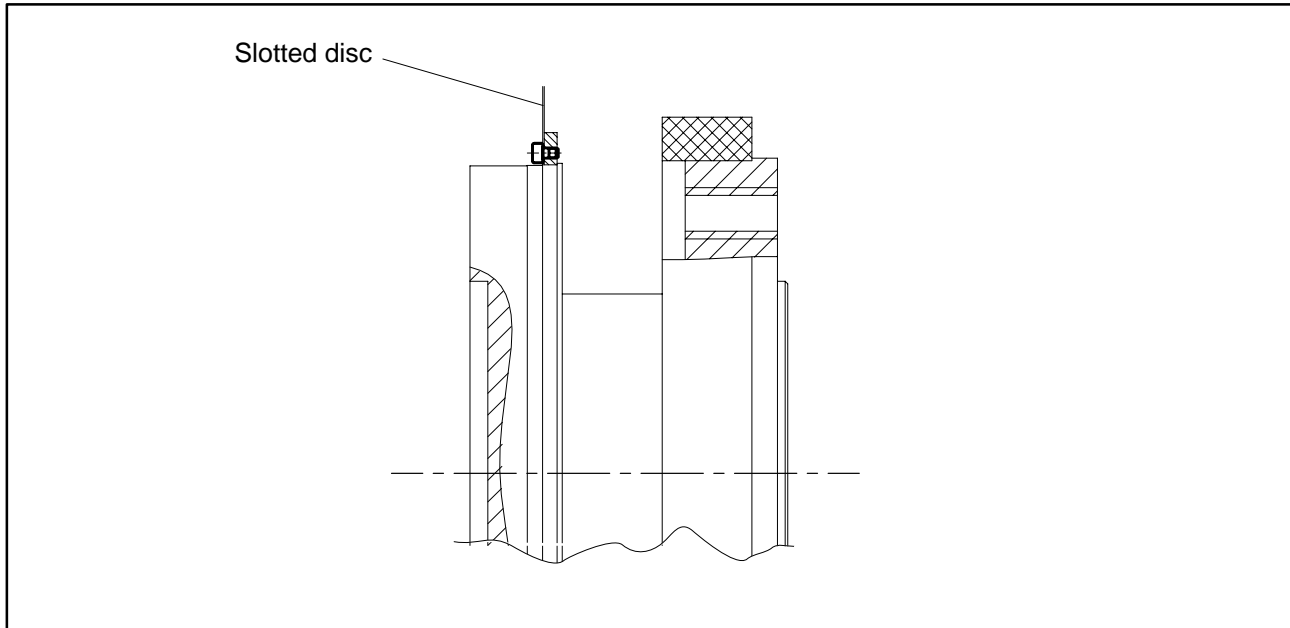

**Fig. 4.4:** Mounting of clamping part

## 4.7 Installing the slotted disc (speed measuring system)

To prevent the slotted disc of the speed measuring system being damaged in transit, it is not mounted on the rotor in the case of gauging flanges with option 2, code L (nominal (rated) speed 8000 rpm to 12000 rpm). Before installing the rotor, it must be attached in the shaft run. The associated speed sensor is already mounted on the sensor.

The requisite screws, a suitable screwdriver and the screw locking device are included in the list of components supplied.



**Fig. 4.5:** Mounting the slotted disc on the rotor



### CAUTION

**When carrying out installation work, be careful not to damage the slotted disc!**

### Assembly sequence

1. Push the slotted disc onto the rotor and align the screw holes.
2. Apply some of the screw locking device to the screw thread and tighten the screws (tightening torque < 15 N·cm).

## 4.8 Fitting the mounting elements (speed measuring system)

Three mounting elements with screws are included with the torque flange to prevent the slotted disc being damaged during installation. The mounting elements hold the rotor centrally in the antenna ring, making installation easier and safer.



### CAUTION

The mounting elements are only an aid to installation and must be removed before the initial operation of the torque flange!

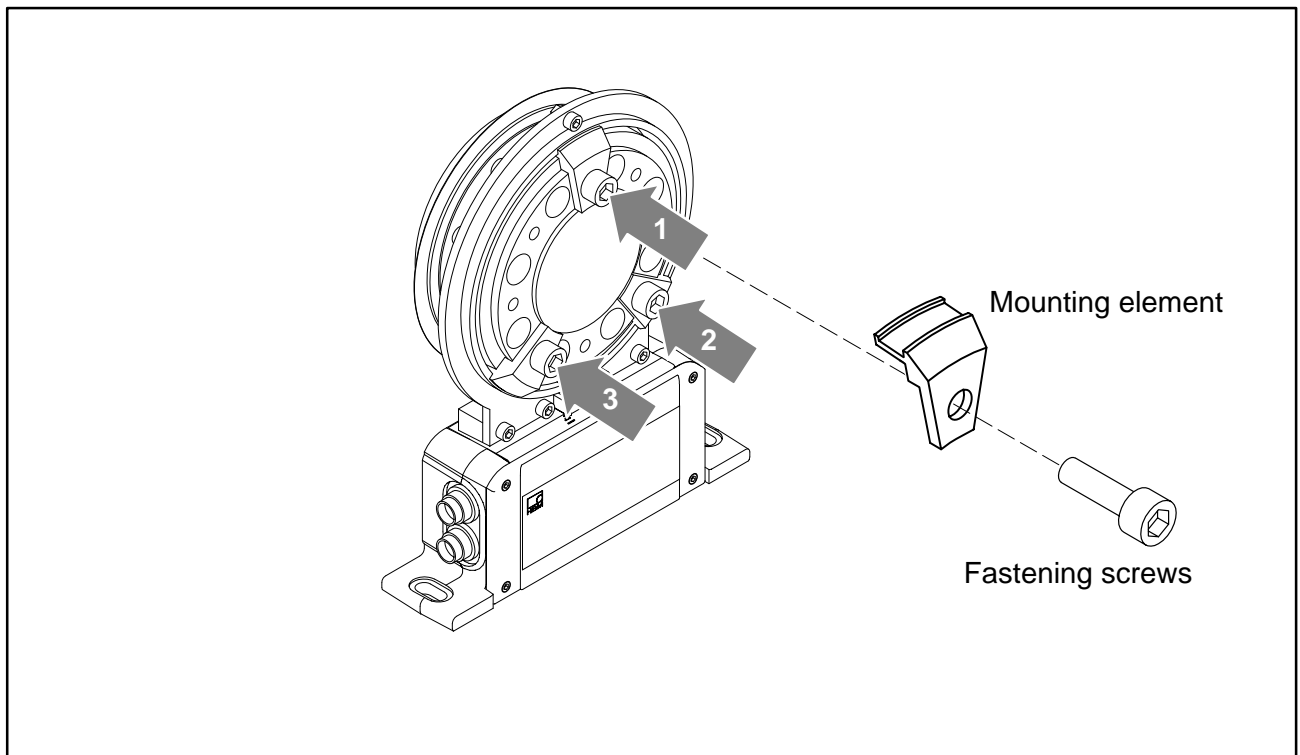

**Fig. 4.6:** Inserting the mounting elements

### 4.8.1 Fixing the mounting elements

1. Place the rotor with the identification plate upward on a flat base.
2. Hold the stator at a slight slant and push it over the rotor until the slotted disc is located in the optical sensor (Step A, Fig. 4.7).
3. Tilt the stator over the rotor until the antenna ring completely covers the transformer (Step B, Fig. 4.7).

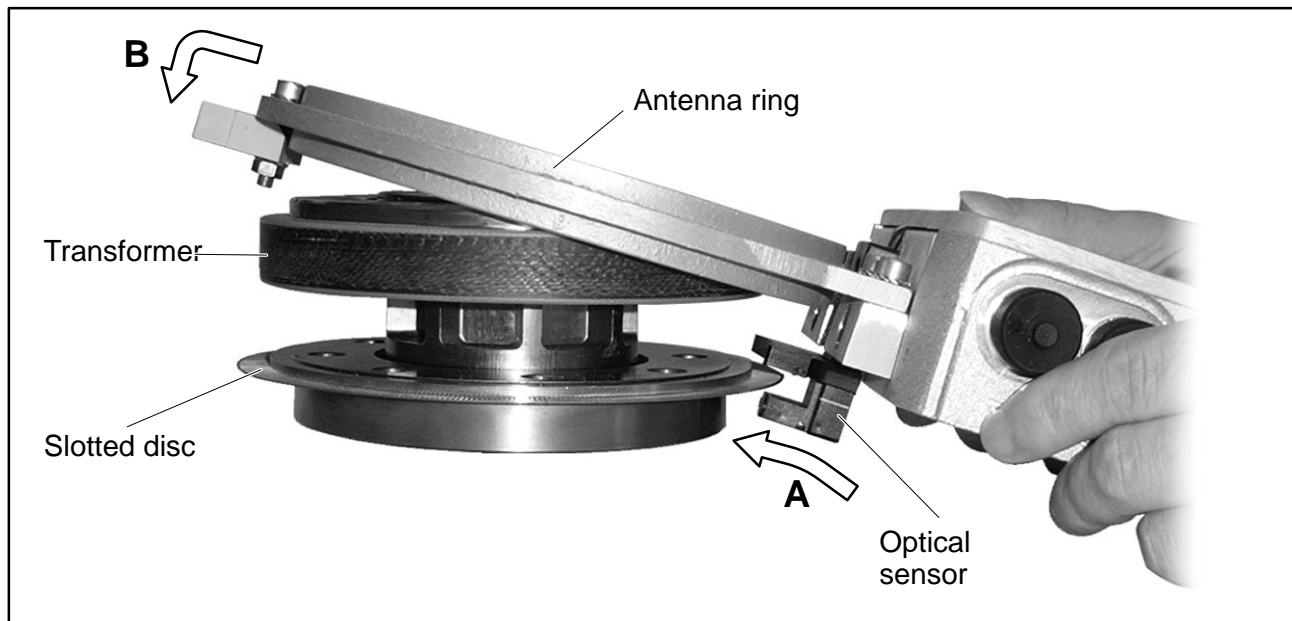

**Fig. 4.7:** Installing the mounting elements

4. Hold the stator centrally over the rotor and one after the other, push the three mounting elements between the transformer and the antenna ring. The mounting elements should be evenly distributed around the circumference (approx. every 120 °).
5. Screw the fastening screws of the mounting elements into the tapped holes of the flange and gently tighten it by hand.

### 4.8.2 Mounting the torque flange with the speed measuring system

1. Mount the torque flange in the shaft run so that the bearing surface of the stator base lies on the prepared mounting surface free from play and stress.
2. Fasten the rotor with 8 screws in the shaft run (for resistance class, see Table 4.1, Page 17). Initially, the screws should only be hand-tight.
3. Compensate for any possible misalignment of the stator by putting adjusting washers underneath or by adjusting the base.



4. Fasten the base retaining screws; only tighten them gently at first, so that the mounting element does not get jammed.
5. Remove the mounting elements (if a mounting element should get jammed, try to move it to the left or right).



### **NOTE**

**It is essential to keep the mounting elements and fastening screws in case any modifications are needed!**

6. Tighten the stator retaining screws. The stator must rest at the markers or stops. The rotor must turn freely.
7. Check whether the axial and radial tolerances have been maintained.
8. With a torque wrench, definitively tighten the fastening screws of the rotor in a diagonally opposite sequence (for tightening torques, see Table 4.1, Page 17).
9. Use a test run (starting at low rotation speeds) to check the correct concentricity of the rotor.

When machines are flexibly suspended, fairly large radial and longitudinal movements may occur. If the motion exceeds the permitted limits (see Specifications, Page 51 foll.), you must make sure that the stator follows the sequence of motions of the rotor.

When couplings are inserted, possible longitudinal and radial play must also be taken into account.

## 4.9 Aligning the stator (speed measuring system)

The stator can be mounted in any position (for example, "upside down" installation is possible).

For measuring mode to operate perfectly, the slotted disc of the speed measuring system must rotate at a defined position in the optical sensor.

### Axial alignment

There are markers in the optical sensor for axial alignment (orientation lines). When installed, the slotted disc should be exactly above these orientation lines. Deviations of up to  $\pm 2$  mm are permissible in measuring mode (total of static and dynamic shift).

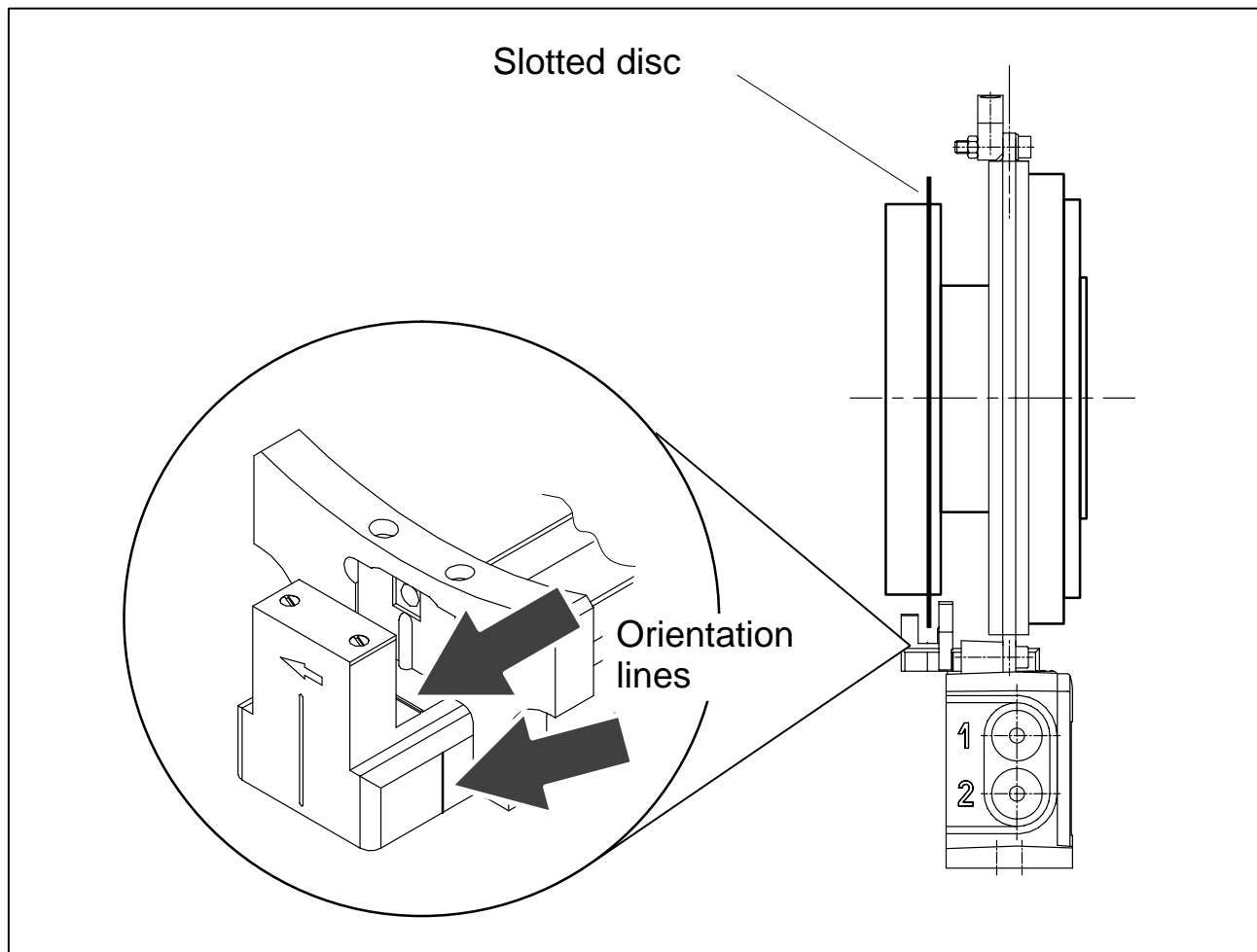

**Fig. 4.8:** Position of the slotted disc in the speed sensor



### NOTE

To attach the stator, we recommend the use of M6 screws with plain washers (width of oblong hole, 9 mm). This size of screw guarantees the necessary travel for alignment.

### Radial alignment

The rotor axis and optical axis of the speed sensor must be along a line at right angles to the stator platform. A vertical marker line on the head of the sensor serves as an orientation guide.

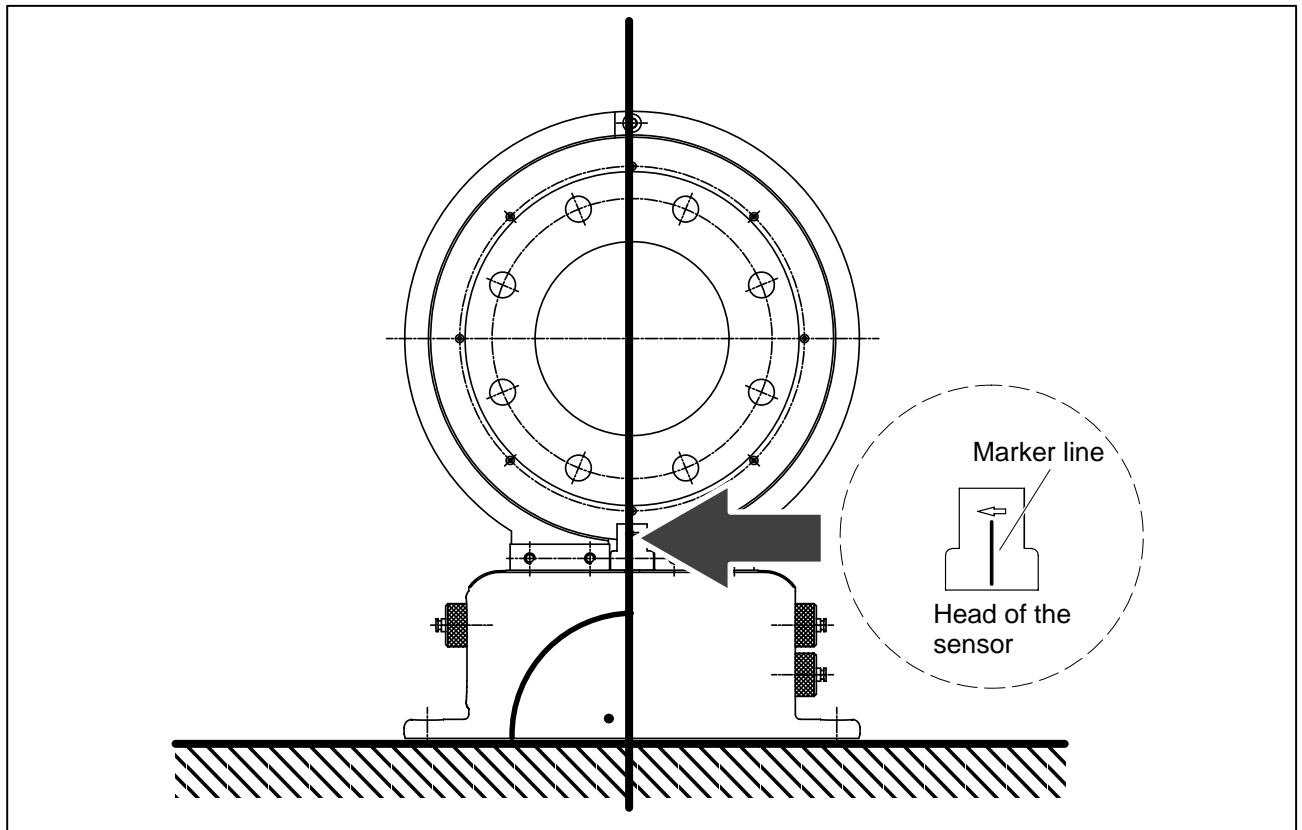

**Fig. 4.9:** Orientation markers on the stator

## 5 Electrical connection



### CAUTION

Transducer connection cables from HBM with attached connectors are identified in accordance with their intended purpose (Md or n). When cables are shortened, inserted into cable ducts or installed in control cabinets, this identification can get lost or become concealed. If this is the case, it is essential for the cables to be re-labelled!

### 5.1 Shielding design

The cable shielding is connected in accordance with the Greenline concept. This encloses the measurement system (without a rotor) in a Faraday cage. It is important that the shield is laid flat on the housing ground at both ends of the cable. Any electromagnetic interference active here does not affect the measurement signal. Special electronic coding methods are used to protect the transmission path and the rotor from electromagnetic interferences.

In the case of interferences due to potential differences (compensating currents), operating-voltage zero and housing ground must be disconnected on the amplifier and a potential equalisation line between stator housing and amplifier housing must be established (copper conductor, 10 mm<sup>2</sup> wire cross-section).

If potential differences arise between the rotor and the stator on the machine, perhaps due to unchecked leakage, and this causes interference, it can usually be overcome by connecting the rotor directly to earth, for instance by a wire loop. The stator should be fully earthed in the same way.

## 5.2 Option 2, code KF1

The stator housing has a 7-pin (Binder 723) male device connector, to which you link the connection cable for voltage supply and torque signal.

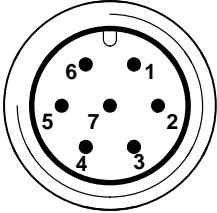
 <p><b>Binder 723</b></p> <p>Top view</p>	Plug Binder Pin	Pin assignment	Wire co- lour	MS3106 plug Pin
	1	Zero operating voltage	WH	A
	2	No function	BK	B
	3	Preamplifier supply voltage (+15 V)	BU	C
	4	Torque measurement signal (12 V <sub>PP</sub> ; 5...15 kHz)	RD	D
	5	No function		
	6	Rotor excitation voltage (54 V/80 V <sub>PP</sub> ; approx.15 kHz)	GN	F
	7	Excitation voltage rotor (0 V)	GY	G
		Shielding connected to enclosure ground		

### 5.2.1 Adaptation to the cable length

The transmission method between the rotor and the stator determines the function of the torque flange, which is dependent on:

- the installation situation (for example, covering, area free of metal parts)
- the cable length
- the tolerances of the excitation voltage supply

To allow for adaptation to the various conditions, there are three switches in the stator housing, which can be accessed by removing the stator cover (see Fig. 5.1).

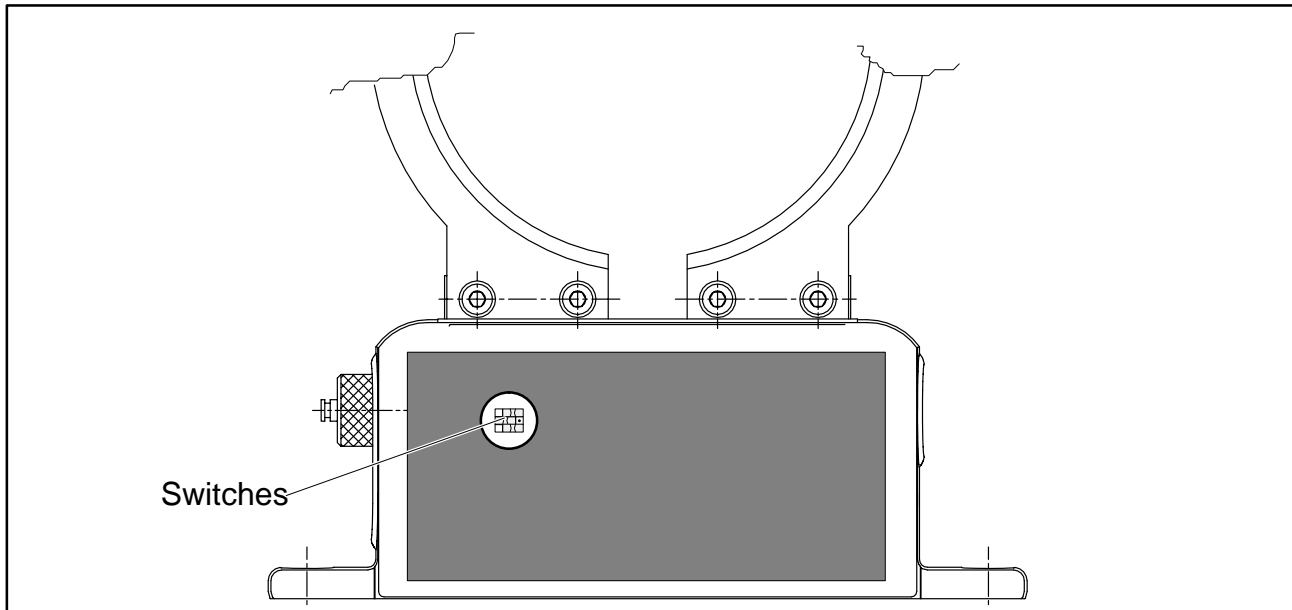

**Fig. 5.1:** Switches in the stator housing

Switch position		Application examples
1		a) Older amplifiers b) For when the calibration signal is unintentionally initiated with very short cable
2		Normal position (factory settings)
3		For cable lengths over approx. 20 m

Please ensure that after switching to switch position 3, the calibration signal is not initiated.

### Possible faults and their elimination:

**Fault:** No signal at the output, amplifier indicates overflow.

**Cause:** Too little power, T10FS disconnects.

**Remedy:** Switch position 3.

**Fault:** The calibration signal has been triggered by mistake.

**Remedy:** Switch position 1.





### 5.3 Option 2, code SF1/SU2

On the stator housing, there are two 7-pin male device connectors (Binder 723) and in the case of the speed module option, there is also an 8-pin male device connector, assigned in accordance with the selected option.

The supply voltage and the calibration signal of plugs 1 and 3 are direct-coupled via multifuses (automatically resetting fuses).

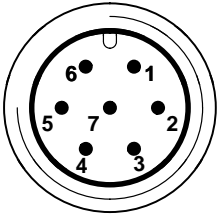
#### Assignment for plug 1:

Voltage supply and frequency output signal.

 <p><b>Binder 723</b></p> <p>Top view</p>	Plug-Binder Pin	Pin assignment	Wire colour	Sub-D connector Pin
	1	Measurement signal torque (frequency output; 5 V <sup>1)</sup> ;  /0 V)	WH	13
	2	Supply voltage 0 V; 	BK	5
	3	Supply voltage 18V ... 30 V	BU	6
	4	Measurement signal torque (frequency output; 5 V <sup>1)</sup> /12 V)	RD	12
	5	Measurement signal 0 V;  symmetrical	GY	8
	6	Calibration signal (external trigger 5 V...30 V	GN	14
	7	Calibration signal 0 V; 	GY	8
	Shielding connected to enclosure ground			



1) Factory settings; RS422 complementary signals



#### CAUTION

The torque flanges of option 3, code SF1/SU2 are only intended for operation with a DC supply voltage. They must not be connected to older HBM measuring amplifiers with square-wave excitation. This could lead to the destruction of the connection board resistances, or other errors in the measuring amplifiers (the torque flange, on the other hand, is protected and once the proper connections have been re-established, is ready for operation again).

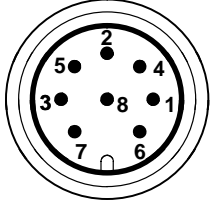

### Assignment Plug 2: Speed measuring system

 <p><b>Binder 723</b></p> <p>Top view</p>	Plug Binder Pin	Pin assignment	Wire colour
	1	Measurement signal rotation speed (pulse sequence, 5 V <sup>1</sup> ); 0°	RD
	2	No function	–
	3	Measurement signal rotation speed (pulse sequence, 5 V <sup>1</sup> ); 90° out-of-phase) <sup>2)</sup>	GY
	4	No function	–
	5	No function	–
	6	Measurement signal rotation speed (pulse sequence, 5 V <sup>1</sup> ); 0°	WH
	7	Measurement signal rotation speed (pulse sequence, 5 V <sup>1</sup> ); 90° out-of-phase) <sup>2)</sup>	GN
	8	Zero operating voltage 	BK
		Shielding connected to enclosure ground	

1) Complementary signals RS 422

2) When switching to double frequency, static direction of rotation signal.

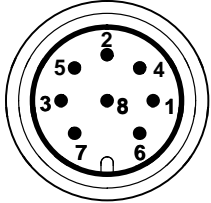
### Assignment Plug 2: Speed measuring system with reference pulse

 <p><b>Binder 723</b></p> <p>Top view</p>	Plug Binder Pin	Pin assignment	Wire colour
	1	Measurement signal rotation speed (pulse sequence, 5 V <sup>1</sup> ); 0°	RD
	2	Reference signal (1 pulse/rev., 5 V <sup>2</sup> )	BU
	3	Measurement signal rotation speed (pulse sequence, 5 V <sup>1</sup> ); 90° out-of-phase) <sup>2)</sup>	GY
	4	Reference signal (1 pulse/rev., 5 V <sup>2</sup> )	BK
	5	No function	
	6	Measurement signal rotation speed (pulse sequence, 5 V <sup>1</sup> ); 0°	WH
	7	Measurement signal rotation speed (pulse sequence, 5 V <sup>1</sup> ); 90° out-of-phase) <sup>2)</sup>	GN
	8	Zero operating voltage 	YE
		Shielding connected to enclosure ground	



1) Complementary signals RS 422

2) When switching to double frequency, static direction of rotation signal.

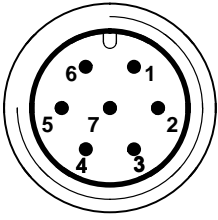

**Assignment for plug 3:**

Voltage supply and voltage output signal.

 <p>Binder 723</p> <p>Top view</p>	Plug Binder Pin	Pin assignment
	1	Measurement signal torque (voltage output; 0 V <sub>meas</sub> )
	2	Supply voltage 0 V; 
	3	Supply voltage 18 V to 30 Vdc
	4	Mesurement signal torque (voltage output, ± 10 V)
	5	No function
	6	Calibration signal trigger 5 V...30 V
	7	Calibration signal 0 V; 
		Shielding connected to enclosure ground

## 5.4 Supply voltage

The notes in this chapter relate to the standalone operation of the T10FS without HBM system solutions.

The supply voltage is electrically isolated from signal outputs and calibration signal inputs. Connect a separated extra-low voltage of 18 V ...30 V to pin 3 (+) and pin 2 () of plug 1 or 3. We recommend that you use HBM cable KAB 8/00–2/2/2 and relevant Binder sockets, that at nominal (rated) voltage (24 V) can be up to 50 m long and in the nominal (rated) voltage range, 20 m long (see Accessories, Page 50). If the permissible cable length is exceeded, you can supply the voltage in parallel over two connection cables (plug 1 and 3). This enables you to double the permissible length. Alternatively an on-site power pack should be installed.

If you feed the supply voltage through an unshielded cable, the cable must be twisted (interference suppression). We also recommend that a ferrite element should be located close to the connector on the cable, and the stator should be earthed.



### CAUTION

**At the instant of switching on, a current of up to 2 A may flow and this may switch off power packs with electronic current limiters.**

## 6 Calibration

T10FS torque flanges deliver an electrical calibration signal that can be switched at the amplifier end for measurement chains with HBM components. The gauging flange generates a calibration signal of about 50 % of the nominal (rated) torque. The precise value is specified on the identification plate. Adjust the amplifier output signal to the calibration signal supplied by the connected torque flange to adapt the amplifier to the gauging flange.



### NOTE

**The gauging flange should not be under load when the calibration signal is being measured, since the calibration signal is mixed additively.**



### CAUTION

**To maintain measurement accuracy, the calibration signal should be connected for no more than 5 minutes. A similar period is then needed as a cooling phase before triggering the calibration signal again.**

### 6.1 Calibration Option2, code KF1

Increasing the excitation voltage from 54 V<sub>PP</sub> to 80 V<sub>PP</sub> (pins 6 and 7, plug 1), triggers the calibration signal.

### 6.2 Calibration Option2, code SF1/SU2

Applying a 5 V separated extra-low voltage to pins 6 (+) and 7(⊖) on plug 1 or 3, triggers the calibration signal.

The nominal (rated) voltage for triggering the calibration signal is 5 V (triggered when  $U > 2.7$  V). The trigger voltage is galvanically isolated from the supply voltage and the measurement voltage. The maximum permissible voltage is 30 V. At voltages lower than 0.7 V, the gauging flange is in measuring mode. Current consumption at nominal (rated) voltage is approx. 2 mA and at maximum voltage is approx. 22 mA.



### NOTE

**In the case of HBM system solutions, the measuring amplifier triggers the calibration signal.**

# 7 Settings



## NOTE

You will find a table containing all the relevant switch positions on the back of the stator cover. Changes to the factory settings should be noted here using a waterproof felt-tip pen.





Einstellungen / Settings OPTION 5								
Impulse/Umdrehungen Pulses/rotation	360	180	90	60	30	15	720	
$M_{nom}$ 500 N·m bis 3 kN·m								WERKSEINSTELLUNG Factory settings Eigene Einstellungen Customized settings <input checked="" type="checkbox"/> <input type="checkbox"/>
$M_{nom}$ 5 kN·m bis 10 kN·m								
 Hysteresese Hysteresis	ein / on <input checked="" type="checkbox"/>				aus / off <input type="checkbox"/>			ON DIP  1 2 3 4 5 6
Frequenz Ausgangsspannung Frequency output voltage	CH1 CH2 <input checked="" type="checkbox"/>				CH1  2 x f CH2 <input type="checkbox"/>			

Fig. 7.1: Sticker with the switch positions

## 7.1 Torque output signal, code KF1

The factory setting for the frequency output voltage is 12 V (asymmetrical). The frequency signal is on pin 4 opposite pin 1. Switching is not possible.

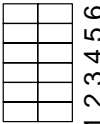
## 7.2 Torque output signal, code SF1/SU2

The factory setting for the frequency output voltage is 5 V (symmetrical, complementary RS422 signals). The frequency signal is on pin 4 opposite pin 1. You can change the output voltage to 12 V (asymmetrical). To do this, change switches S1 and S2 to position 1 (and pin 1 → ).

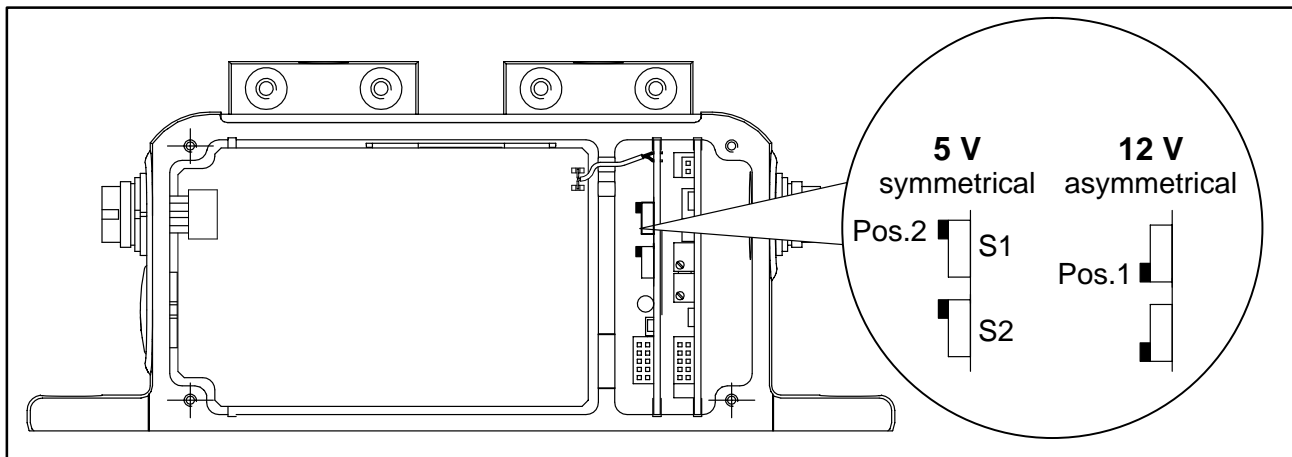

**Fig. 7.2:** Switch for changing the frequency output voltage

## 7.3 Setting up the zero point

In the case of the torque flange with the voltage output option (SU2), you can access two potentiometers by removing the stator cover. You can use the zero point potentiometer to correct certain zero point deviations. The balancing range is a minimum of  $\pm 400$  mV at nominal (rated) gain. The end point potentiometer is used for compensation at the factory and is capped with varnish so that it cannot be turned unintentionally.



## CAUTION

Turning the end point potentiometer changes the factory calibration of the voltage output.

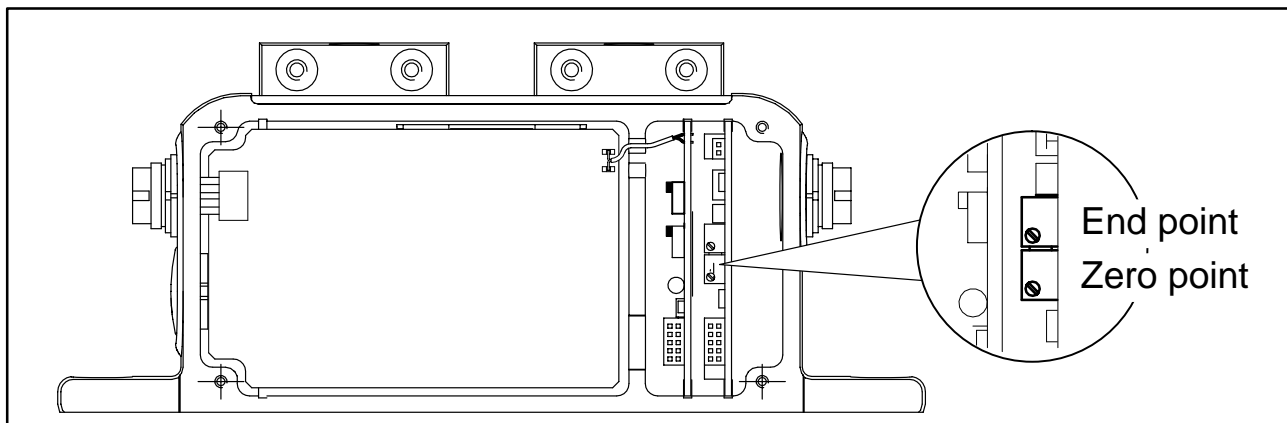

Fig. 7.3: Setting up the voltage output zero point

## 7.4 Functional testing

### 7.4.1 Power transmission

If you suspect that the transmission system is not working properly, you can remove the stator cover and test for correct functioning. If the LED is on, the rotor and stator are properly aligned and there is no interference with the transmission of measuring signals. When the calibration signal is triggered, the LED shines more brightly.

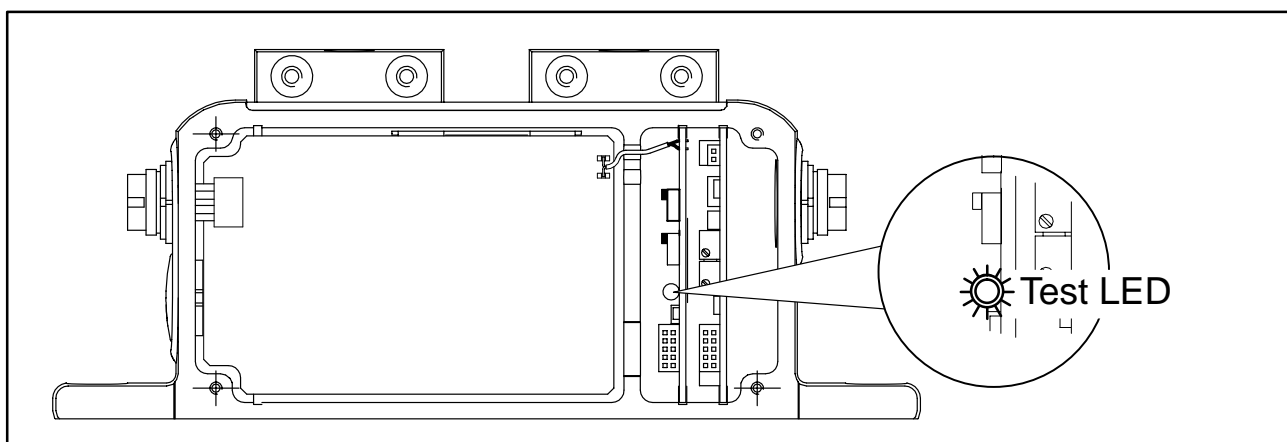

Fig. 7.4: Functional test for power transmission

### 7.4.2 Alignment of the speed module

When required, you can test the correct functioning of the speed measuring system.

1. Remove the cover of the stator housing.
2. Turn the rotor by at least 2 rpm.

If both the control LEDs come on while you are turning the rotor, the speed measuring system is properly aligned and fully operational.

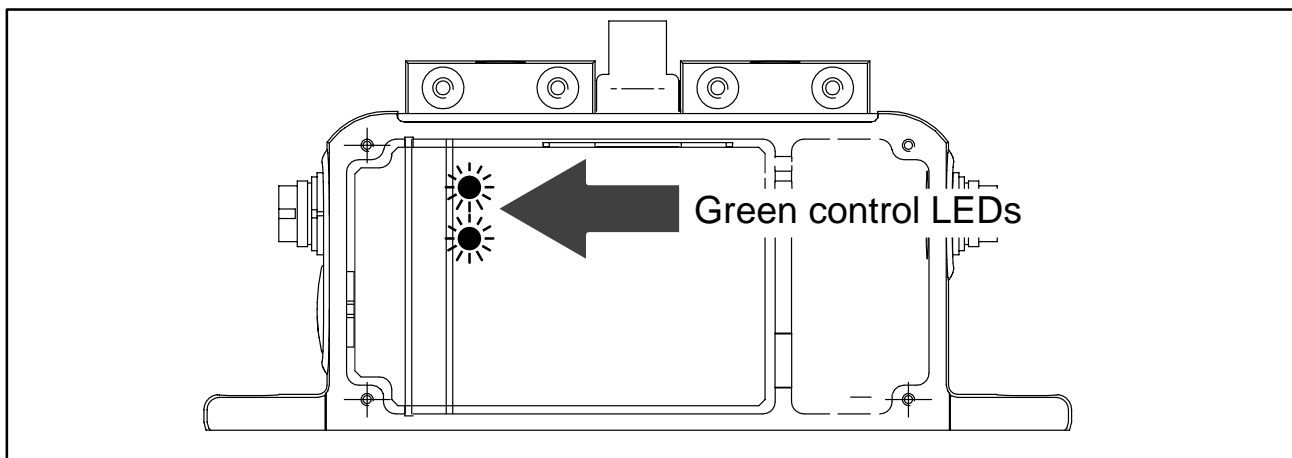

Fig. 7.5: Control LEDs of the speed measuring system



### CAUTION

When closing the cover of the stator housing, make sure that the internal connector cables are positioned in the grooves provided and are not caught up.

## 7.5 Setting the pulse count



### NOTE

The factory setting is 360 pulses/revolution. Please make sure that when you change the pulse count, you also change the pulse duration!

$$\text{puls duration} = \frac{1}{2 \cdot \text{puls count} \cdot \text{rotation speed}}$$

In the case of the speed module option, the number of pulses per revolution of the rotor can be adjusted by using DIP switches S1...S4.

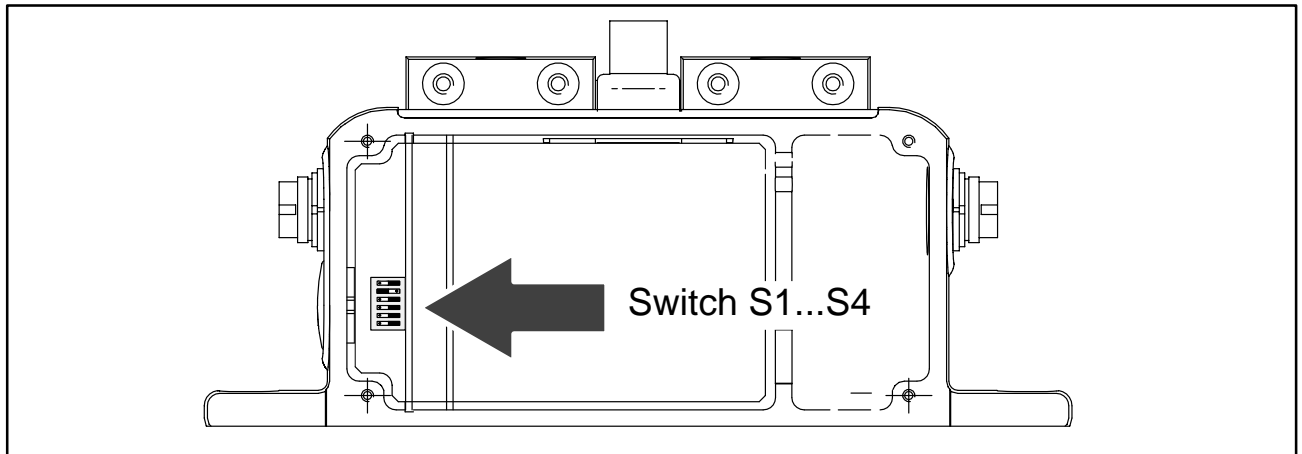

Fig. 7.6: Switches for setting the pulse count

### Setting the pulse count

1. Remove the stator cover.
2. Use switches S1...S4 in accordance with Table 7.1 to set the required pulse count.

Pulses/revolution	360 <sup>1)</sup>	180	90	60	30	15	720
Nominal (rated) torque 500 N·m ... 3 kN·m							
Nominal (rated) torque 5 kN·m ... 10 kN·m							

Table 7.1: Switch position for the pulse count (■  $\triangle$  switch lever)

<sup>1)</sup> Factory settings

## 7.6 Vibration suppression (hysteresis)

Low rotation speeds and higher relative vibrations between the rotor and the stator can cause disturbance signals that reverse the direction of rotation. Electronic suppression (hysteresis) to eliminate these disturbances is connected at the factory. Disturbances caused by radial stator vibration amplitudes of approx. 2 mm are thus suppressed.

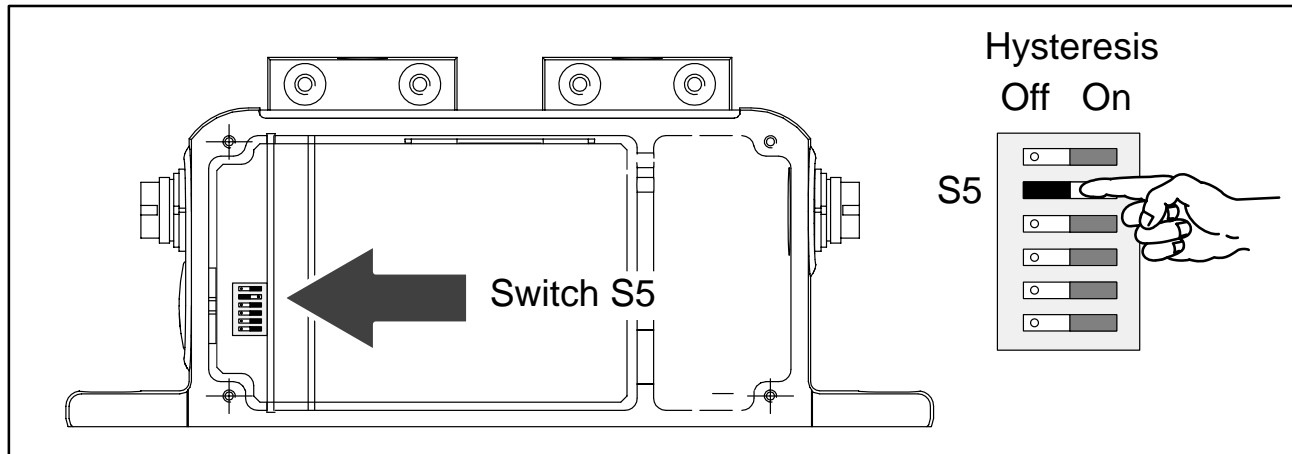
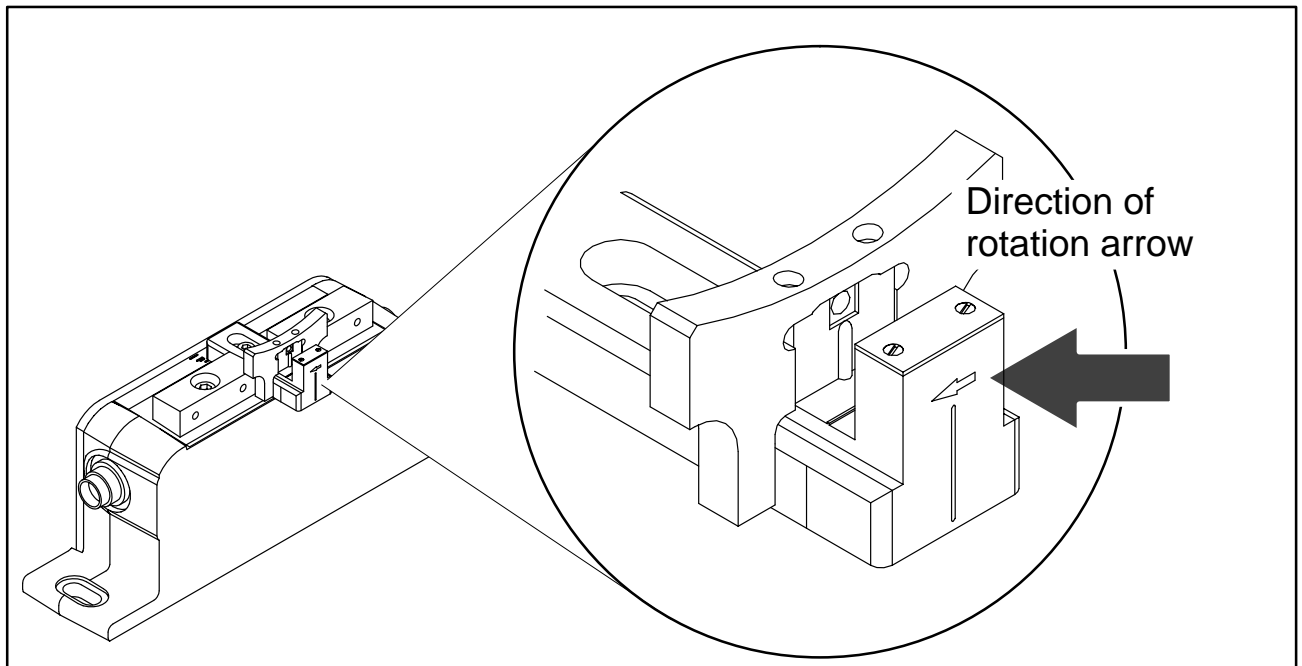

**Fig. 7.7:** Switch for switching off hysteresis



## 7.7 Shape of the rotation speed output signal

In the factory settings, two 90° phase-offset speed signals (5 V symmetrical, complementary RS422 signals) are available. You can double the pulse count set in each case by moving switch S6 to the "On" position. Pin 3 then outputs the direction of rotation as a static direction of rotation signal (pin 3 = +5 V, pin 7 = 0 V opposite pin 8), if the shaft turns in the direction of the arrow. At a rotation speed of 0 rpm, the direction of rotation signal has the last measured value.



**Fig. 7.8:** Direction of rotation arrow on the head of the sensor

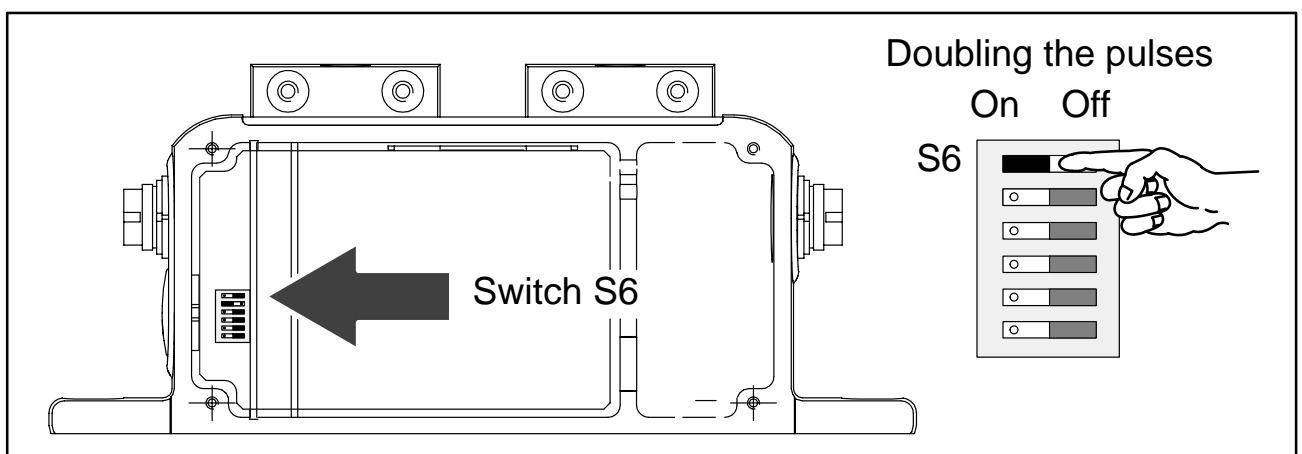

**Fig. 7.9:** Switch for doubling the pulses

## 7.8 Type of rotation speed output signal

You can use switch S7 to change the symmetrical 5 V output signal (factory setting) to an asymmetrical signal of 0 V ... 5 V.

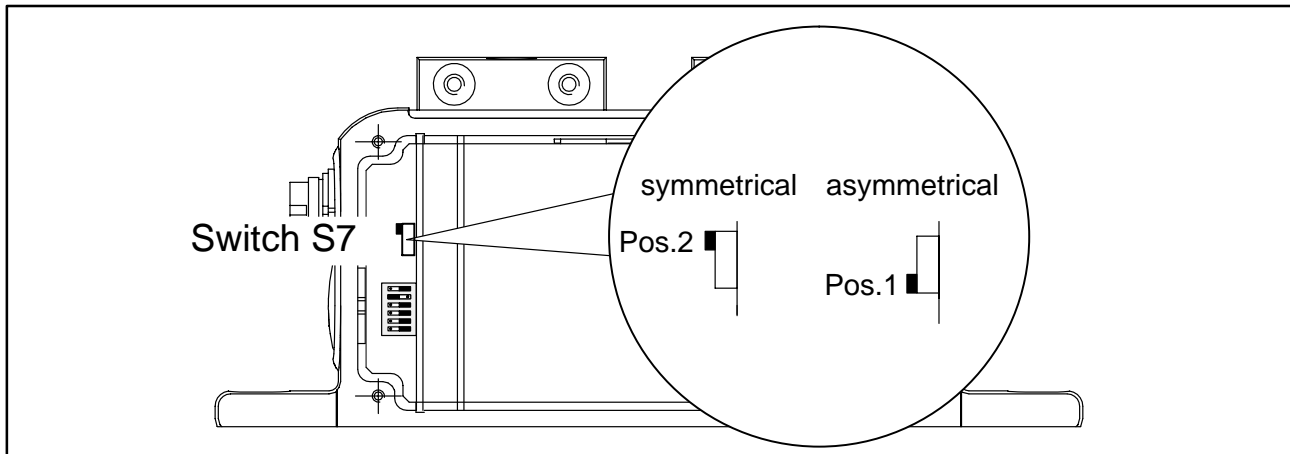

**Fig. 7.10:** Switch S7; symmetrical/asymmetrical output signal

## 7.9 Reference pulse (option)

In the case of the reference pulse option, a magnet is integrated into the slotted disc of the speed measuring system, that generates a pulse at each full revolution of the rotor. The pulse can be picked up at switch 2 (see Page 32).

The reference pulse is synchronised with the rotation speed output signal ( $5\text{ V}^1$ ,  $0^\circ$ ) and is output if the reference marker is passed and a rising edge occurs during the rotation speed signal.

The pulse length corresponds to the length of a speed increment which depends on the selected pulse number and on the speed (see Page 39 for computation).

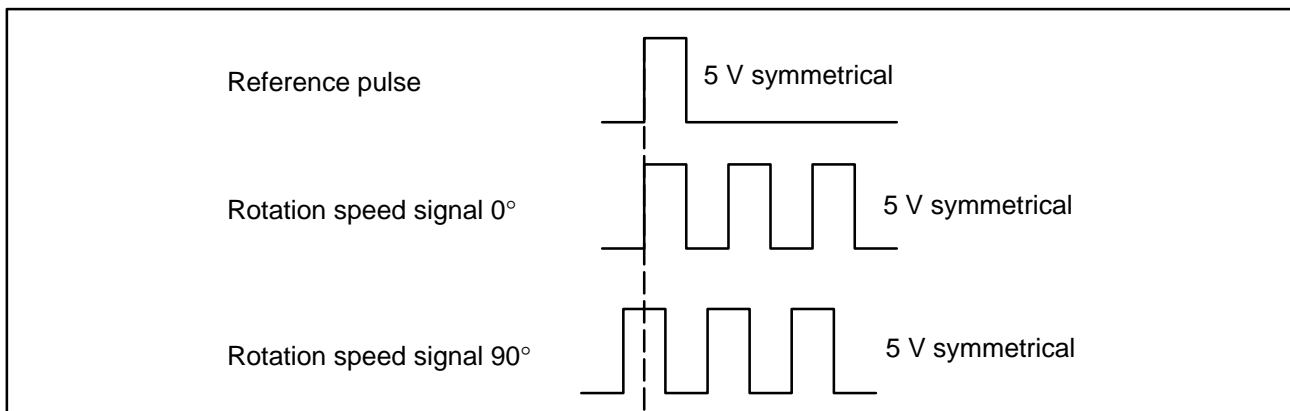

**Fig. 7.11:** Electrical condition of the reference pulse

<sup>1)</sup> Complementary signals RS 422

LED L4 flashes (minimum speed 2 rpm) and is on permanently from approx. 1000 rpm, if the speed measuring system and the reference pulse are properly synchronised. If the LED is **not** on, please change switch S8 (see Fig. 7.12).



## CAUTION

Viewed from above the opened stator housing, switch S8 is behind switch S7.

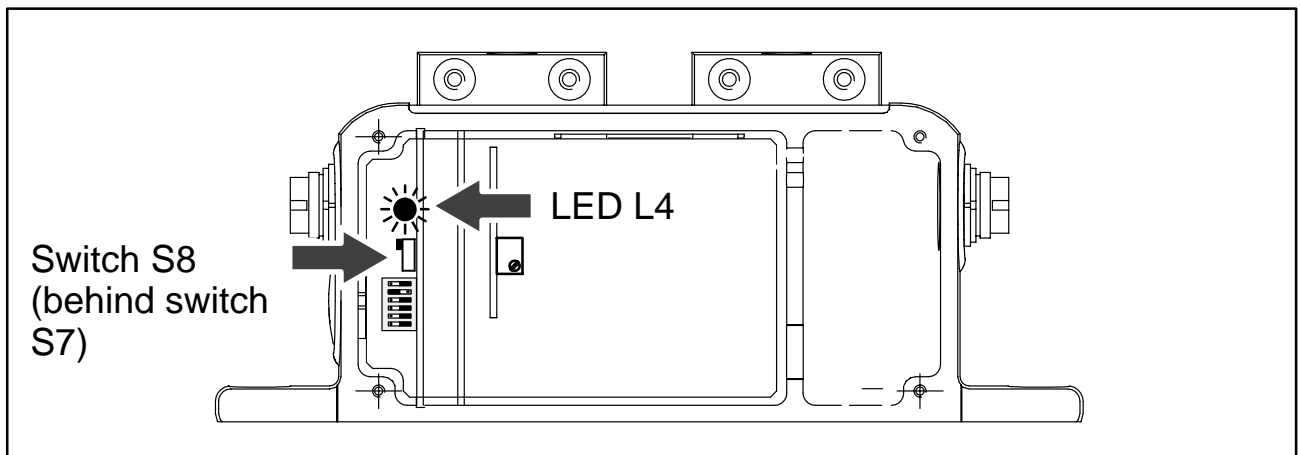

**Fig. 7.12:** Switch S8; optimising the reference pulse

## 8 Loading capacity

Nominal (rated) torque can be exceeded statically up to the limit torque. If nominal (rated) torque is exceeded, additional irregular loading is not permissible. This includes longitudinal forces, lateral forces and bending moments. Limit values can be found in the "Specifications" chapter, Page 51.

### 8.1 Measuring dynamic torque

The torque flanges can be used to measure static and dynamic torques. The following applies to the measurement of dynamic torque:

- The T10FS calibration made for static measurements is also valid for dynamic torque measurements.
- The natural frequency  $f_0$  for the mechanical measuring system depends on the moments of inertia  $J_1$  and  $J_2$  of the connected rotating masses and the T10F's torsional stiffness.

Use the below equation to determine the natural frequency  $f_0$  for the mechanical measuring system:

$$f_0 = \frac{1}{2\pi} \cdot \sqrt{c_T \cdot \left( \frac{1}{J_1} + \frac{1}{J_2} \right)}$$

$f_0$	=	Natural frequency in Hz
$J_1, J_2$	=	Mass moment of inertia in $\text{kgm}^2$
$c_T$	=	Torsional stiffness in $\text{Nm/rad}$

- The vibration bandwidth (peak-to-peak) must never exceed 200% of the nominal (rated) torque rated for the T10FS, even in the event of alternating load. In all cases the vibration bandwidth must lie within the loading range defined by  $-M_{nom}$  and  $+M_{nom}$ . The same also applies to transient resonance points.

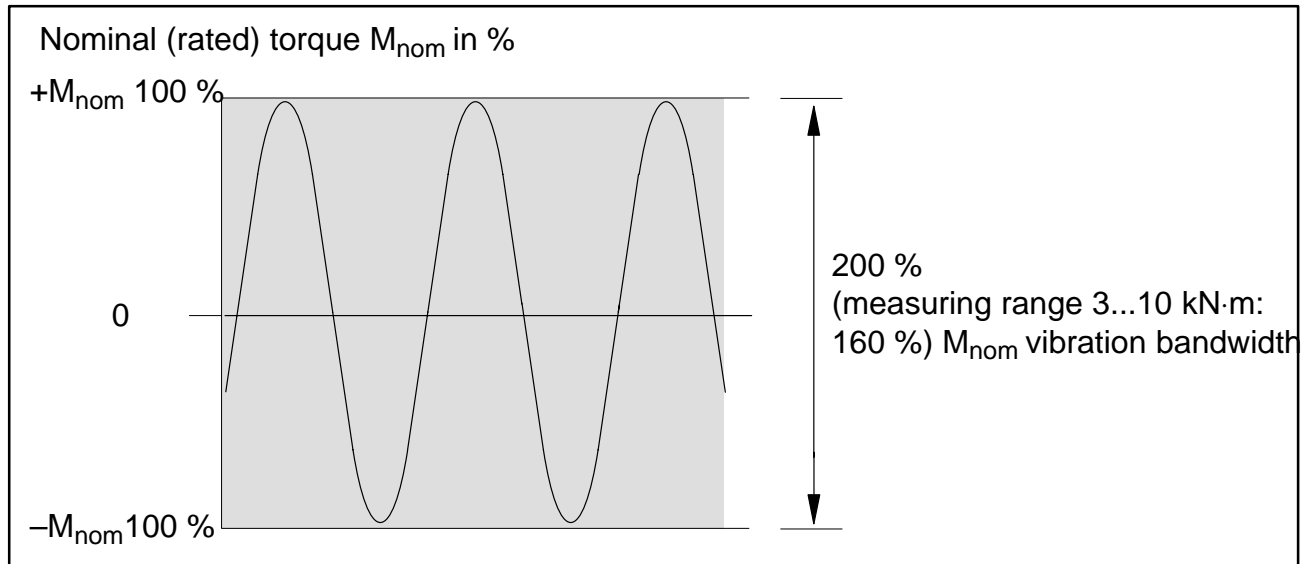

**Fig. 8.1:** Permissible dynamic loading

## 9 Maintenance

Torque flanges are maintenance free.

### 9.1 Speed module maintenance

During operation and depending on the ambient conditions, the slotted disc of the rotor and the associated stator sensor optics can get dusty. This will become noticeable when the polarity of the display changes. Should this occur, the sensor and the slotted disc must be cleaned.

1. Use compressed air (up to 6 bar) to clean the slotted disc.
2. Carefully clean the sensor optics with a dry cotton bud or one which has been soaked in spirit. **Do not use any other solvent!**

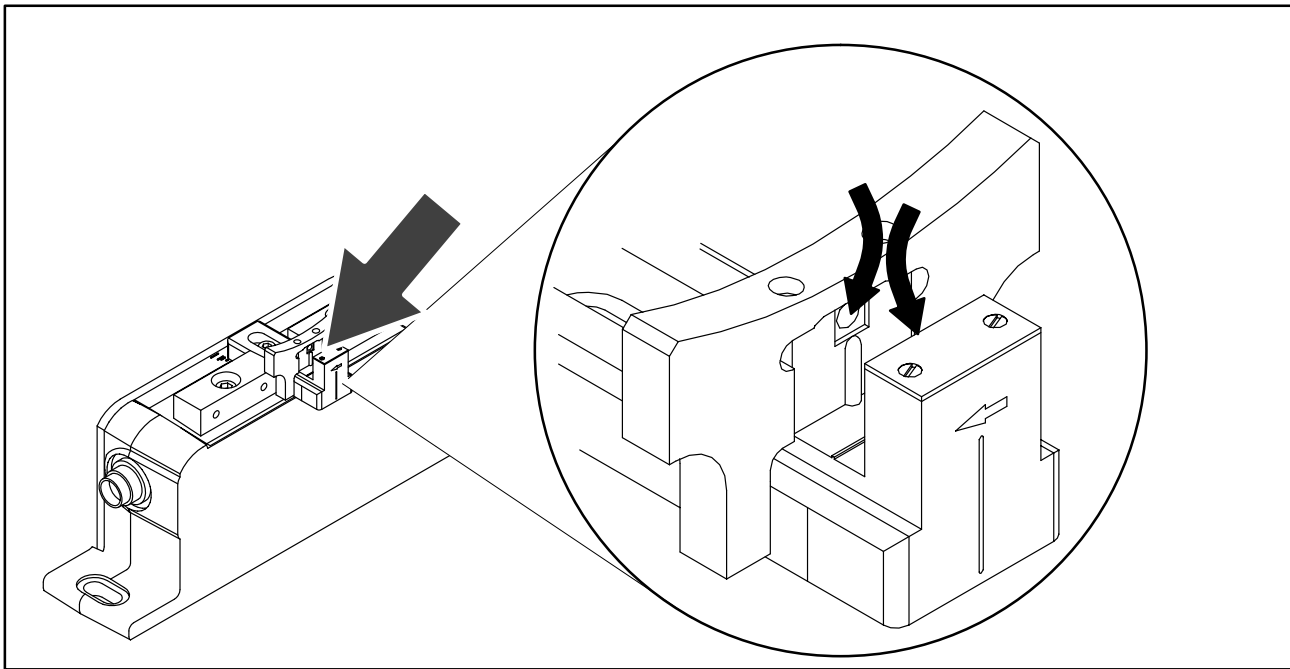

**Fig. 9.1:** Cleaning points on the speed sensor

# 10 Dimensions

## 10.1 Rotor dimensions

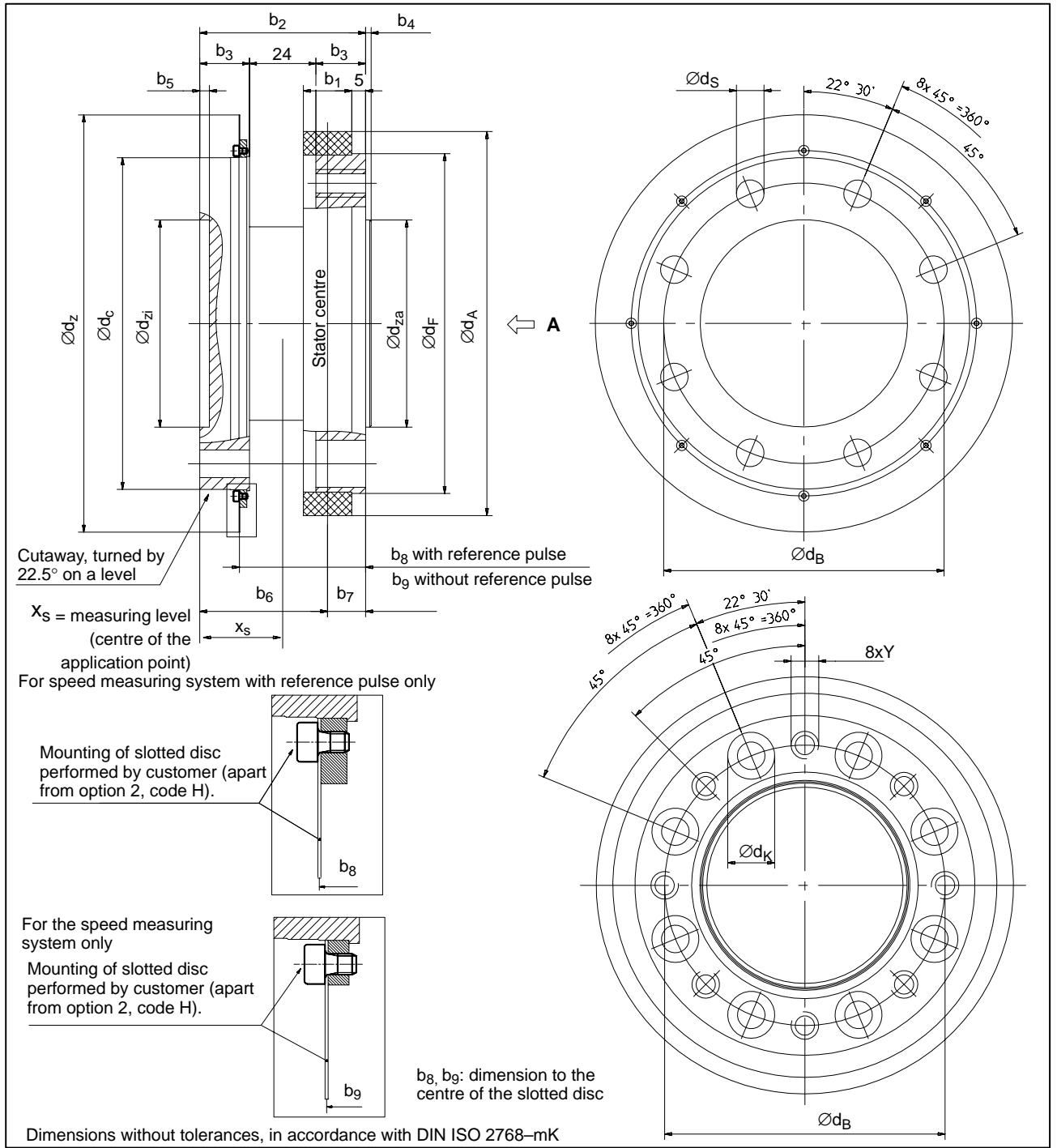

Measuring range	Dimensions in mm										
	$b_1$	$b_2$	$b_3$	$b_4$	$b_5$	$b_6$	$b_7$	$b_8$	$b_9$	$x_s$	Y
500 N·m / 1 kN·m	17,5	60	18	2	3,5	46,3	13,7	45,5	45	30	M10
2 kN·m / 3 kN·m	20,5	64	20	2,5	5	48,8	15,2	47,5	47	32	M12
5 kN·m	22,5	84	26	2,8	3	67,8	16,2	62,7	62,7	42	M14
10 kN·m	28,5	92	30	3,5	5	72,8	19,2	66,7	66,7	46	M16

Measuring range	Dimensions in mm								
	$\varnothing d_A$	$\varnothing d_B$	$\varnothing d_C$	$\varnothing d_F$	$\varnothing d_K$	$\varnothing d_S^{C12}$	$\varnothing d_Z$	$\varnothing d_{za\ g5}$	$\varnothing d_{zi}^{H6}$
500 N·m / 1 kN·m	139	101,5	120	123	17	10	151	75	75
2 kN·m / 3 kN·m	175	130	155	160	19	12	187	90	90
5 kN·m	209	155,5	180	188	22	14	221	110	110
10 kN·m	256	196	222	230	26	17	269	140	140

## 10.2 Dimensions stator

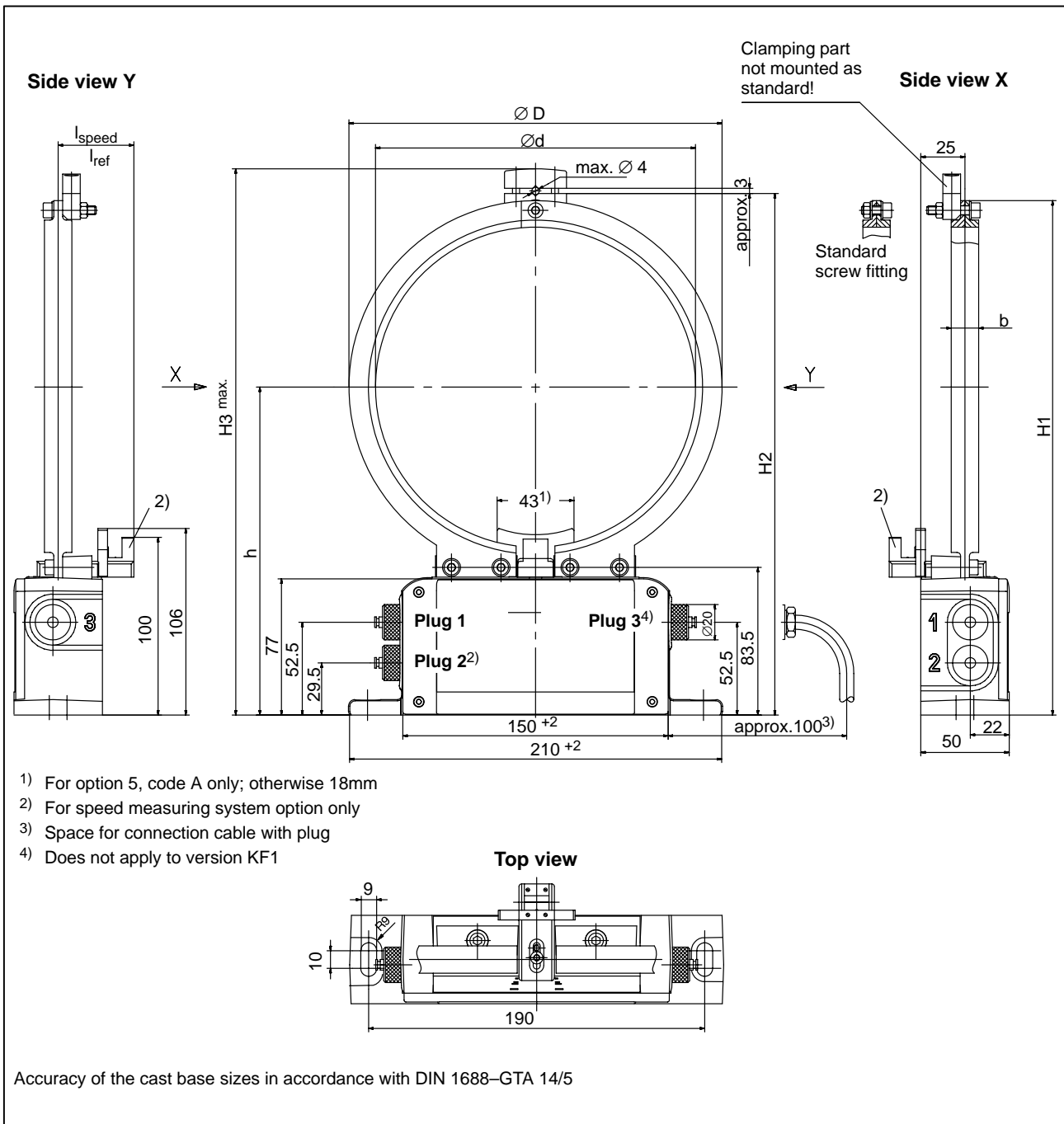

Measuring range	Dimensions in mm								
	b	Ød	ØD	H1	H2	H3	h	l <sub>speed</sub>	l <sub>ref</sub>
500 N·m 1 kN·m	17,5	145	175	255	259	273	167,5	42	42,5
2 kN·m 3 kN·m	20,5	181	211	291	295	309	185,5	42,5	43
5 kN·m	22,5	215	245	324	329	343	202,5	57	57
10 kN·m	28,5	263	293	373	377	391	226,5	58	58



### 10.3 Mounting dimensions

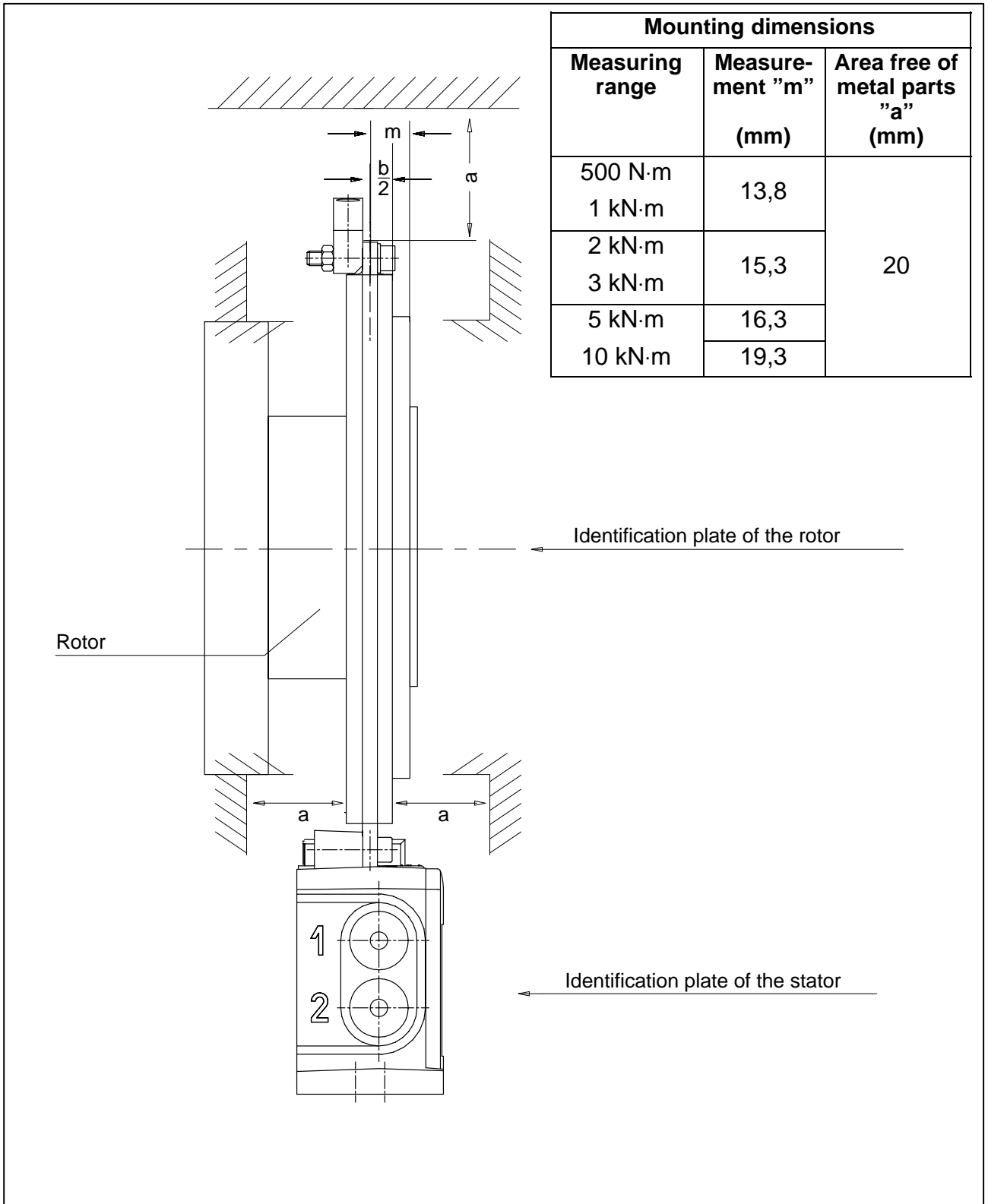

# 11 Order-No., accessories

Code	Option 1: measuring range
500Q	N·m
001R	1 kN·m
002R	2 kN·m
003R	3 kN·m
005R	5 kN·m
010R	10 kN·m

Code	Option 2: nominal (rated) speed
L	Nominal (rated) speed dependent on measuring range from 8000 rpm to 12000 rpm
H	Nominal (rated) speed dependent on measuring range from 12000 rpm to 22000 rpm

Code	Option 3: electrical configuration
KF1	Output signal 10 kHz $\pm$ 5 kHz, excitation voltage 14 kHz/54 V; square wave
SF1	Output signal 10 kHz $\pm$ 5 kHz, supply voltage 18...30 V dc
SU2	Output signal 10 kHz $\pm$ 5 kHz and $\pm$ 10 V, supply voltage 18...30 V dc

Code	Option 4: accuracy
S	Standard
G	Greater accuracy <sup>1)</sup> Lin. $< \pm 0.03\%$ and $TK_0 < \pm 0.03\%$

Code	Option 5: speed measuring system <sup>2)</sup>
0	Without speed measuring system
1	With speed measuring system
A	With speed measuring system and reference pulse

Code	Option 6: connection cable
0V	Without connection cable
V1	Torque connection cable for KF1, 423 free ends, 6 m
V2 <sup>*)</sup>	Torque connection cable for KF1, 423 free ends, max. 80 m
V3	Torque connection cable for KF1, 423-MS3106PEMV, 6 m
V4 <sup>*)</sup>	Torque connection cable for KF1, 423-MS3106PEMV, max. 80 m
V5	Torque connection cable for SF1/SU2, 423-D-Sub 15P, 6 m
V6 <sup>*)</sup>	Torque connection cable for SF1/SU2, 423-D-Sub 15P, max. 50 m
W1	Torque and rotation speed, one cable each 423-D-Sub 15P, 6 m
W2 <sup>*)</sup>	Torque and rotation speed, one cable each, 423-D-Sub 15P, max. 50 m
W5	Torque and rotation speed with reference pulse, one cable each, 423 free ends, 6 m
W6 <sup>*)</sup>	Torque and rotation speed with reference pulse, one cable each, 423 free ends, max. 50 m

Code	Option 7: accessories
N	Without accessories

- 1) For voltage output:  
Lin.  $< \pm 0.05\%$ ;  $TK_0 < \pm 0.13\%$
- 2) For option 3, code SF1, SU2 only

Order-No.:

K-T10FS - [ ] [ ] [ ] [ ] - [ ] - [ ] [ ] [ ] [ ] - [ ] - [ ] [ ] [ ] [ ] - [ ] [ ] [ ] [ ] m<sup>\*)</sup> \*)

Ordering example

K-T10FS - [5] [0] [0] [Q] - [H] - [S] [F] [1] - [S] - [0] - [V] [5] - [N] [ ] [ ] [ ] [ ] m<sup>\*)</sup>

\*) With selections V2, V4, V6 and W2, W6, please specify required length of cable.

## Accessories, to be ordered separately

423G-7S, cable socket 7-pin, straight cable entry, for torque output (plugs 1, 3), order no. 3-3101.0247

423W-7S, cable socket 7-pin, 90 ° cable entry, for torque output (plugs 1, 3), order no. 3-3312.0281

423G-8S, cable socket 8-pin, straight cable entry, for speed output (plug 2), order no. 3-3312.0120

423W-8S, cable socket 8-pin, 90 ° cable entry, for speed output (plug 2), order no. 3-3312.0282

Raw cable Kab8/00-2/2/2, order no. 4-3301.0071

## 12 Specifications

Type		T10FS					
Accuracy class		0.1					
Torque measuring system							
Nominal (rated) torque $M_{nom}$ for reference only	N·m	500	1 k	2 k	3 k	5 k	10 k
	ft·lb	375	750	1,500	2,250	3,750	7,500
<b>Nominal (rated) sensitivity</b> (spread between torque = zero and nominal (rated) torque) Frequency output	kHz	5					
	V	10					
<b>Characteristic tolerance</b> (deviation of the actual output at $M_{nom}$ of the nominal (rated) sensitivity) Frequency output	%	±0.1					
	V	±0.2					
<b>Output signal at Torque = zero</b> Frequency output	kHz	10					
	V	0					
<b>Nominal (rated) output signal</b> Frequency output at positive nominal (rated) torque	kHz	15 (5 V symmetrical <sup>1</sup> )/12 V asymmetrical <sup>2</sup> )					
	kHz	5 (5 V symmetrical <sup>1</sup> )/12 V asymmetrical <sup>2</sup> )					
Voltage output at positive nominal (rated) torque	V	+10					
	V	-10					
<b>Load resistance</b> Frequency output	kΩ	≥2					
	kΩ	≥5					
<b>Long-term drift over 48 h</b> Voltage output	mV	≤±3					
	Hz	0 ... 1000 (-3 dB)					
<b>Group delay</b> Frequency output	ms	0.15					
	ms	0.9					
<b>Residual ripple</b> Voltage output	mV	40 (peak-to-peak)					

1) RS422 complementary signals; factory settings version SF1/SU2

2) Factory settings version KF1 (no switching possible)

## Specifications (continued)

<b>Effect of temperature per 10 K in nominal (rated) temperature range on the output signal, relative to the actual value of the signal span</b>		
Frequency output	%	< ± 0.1
Voltage output	%	< ± 0.2
<b>on the zero signal, relative to the nominal (rated) sensitivity</b>		
Frequency output	%	< ± 0.05 (< ± 0.03 optional)
Voltage output	%	< ± 0.15 (< ± 0.13 optional)
<b>Power supply (version KF1)</b>		
Excitation voltage (square wave)	V	54 ± 5% (peak-to-peak)
Release of calibration signal	V	80 ± 5 %
Frequency	kHz	approx. 14
Max. current consumption	A	1 (peak-to-peak)
<b>Preamplifier excitation voltage</b>	V	0/0/+15
<b>Preamplifier, max. current consumption</b>	mA	0/0/+25
<b>Power supply (version SF1/SU2)</b>		
Nominal (rated) supply voltage (separated extra-low voltage (SELV))	V (DC)	18 ... 30; asymmetrical
Current consumption in measuring mode	A	< 0.9
Current consumption in start-up mode	A	< 2
<b>Nominal (rated) power consumption</b>	W	< 12
<b>Linearity deviation including hysteresis, related to the nominal (rated) sensitivity</b>		
Frequency output	%	< ± 0.05 (< ± 0.03 optional)
Voltage output	%	< ± 0.07 (< ± 0.05 optional)
<b>Rel. standard deviation of reproducibility</b> according to DIN 1319, by reference to variation of the output signal		
Frequency output	%	< ± 0.02
Voltage output	%	< ± 0.03
approx. 50 % of $M_{nom}$ ; value given to the identification plate		
<b>Calibration signal</b>		
<b>Tolerance of calibration signal, related to <math>M_{nom}</math></b>	%	< ± 0.05

## Specifications (continued)

Nominal (rated) torque $M_{nom}$ for reference only	N·m	500	1 k	2 k	3 k	5 k	10 k
	ft-lb	375	750	1,500	2,250	3,750	7,500
<b>Speed measuring system</b>							
<b>Rotation speed measurement system</b>		optical, by means of infrared light and metallic slotted disc					
<b>Mechanical increments</b>	Number	360				720	
<b>Positional tolerance of the increments</b>	mm	± 0.05					
<b>Tolerance of the slot width</b>	mm	± 0.05					
<b>Pulses per rotation</b>							
Electrically adjustable	Number	360 <sup>*)</sup> ; 180; 90; 60; 30; 15				720; 360 <sup>*)</sup> ; 180; 90; 60; 30; 15	
<b>Output signal</b>	V	5 <sup>4)</sup> symmetrical; 2 square-wave signals, approx. 90 ° out-of-phase					
<b>Minimum speed for sufficient pulse stability</b>	rpm	2					
<b>Group delay</b>	µs	< 5 (typically 2.2)					
<b>Hysteresis of reversing the direction of rotation</b> <sup>3)</sup> in the case of relative vibrations between the rotor and the stator							
Torsional vibration of rotor	degree	< approx. 2					
Radial vibration of stator	mm	< approx. 2					
<b>Load resistance</b>	kΩ	≥ 2					
<b>Permitted degree of soiling</b> , in the optical path of the optical sensor (lenses, slotted disc)	%	< 50					
<b>Protection against ambient light</b>		By optical sensor and infrared filter					
<b>Measurement system: reference pulse</b>							
<b>Measurement system</b>		Magnetic, by magnetic-field dependent resistor and magnet, synchronized with rising*) or falling edge of the optical speed measuring system's 0 ° output signal					
<b>Number of pulses per revolution</b>		1					
<b>Output signal</b>	V	5 symmetrical <sup>4)</sup>					
<b>Pulse width</b>		0.5 degrees at 360 speed pulses/revolution (factory setting)					
<b>Minimum speed for sufficient pulse stability</b>	rpm	2					
<b>Group delay time</b>	µs	< 5 (typically 2.2)					
<b>Additional phase errors at</b> speed < 20 rpm speed > 20 rpm	degree degree	typically < 0.1; leading negligible					
<b>Reproducibility at 360 speed pulses/revolution</b>	degree	typ. < ± 0.04 (ideal mounting, non-vibrating operation)					

3) can be switched off

4) complementary signals RS-422

## Specifications (continued)

General specifications								
<b>Nominal (rated) torque <math>M_{nom}</math></b> for reference only	N·m	500	1 k	2 k	3 k	5 k	10 k	
	ft·lb	375	750	1,500	2,250	3,750	7,500	
<b>EMC</b> <b>EME</b> (Emission according to EN61326–1, table 4) RFI field strength	–	Class B						
<b>Immunity from interferences</b> (EN61326–1, table A.1)								
Electromagnetic field AM	V/m	10						
Magnetic field	A/m	30						
<b>ESD</b>								
Contact discharge	kV	4						
Air discharge	kV	8						
Burst	kV	1						
Surge	kV	1						
Line-conducted disturbance (AM)	V	3						
<b>Protection class according to EN 60529</b>		IP 54						
<b>Weight,</b> approx. Rotor	kg	2.4	2.4	4.9	4.9	8.3	14.6	
Stator	kg	1.2	1.2	1.3	1.3	1.3	1.3	
<b>Reference temperature</b>	°C [°F]	+23 [73.4]						
<b>Nominal (rated) temperature range</b>	°C [°F]	+10...+60 [+50...+140]						
<b>Operating temperature range</b>	°C [°F]	–10...+60 [+14...+140]						
<b>Storage temperature range</b>	°C [°F]	–20...+70 [–4...+158]						
<b>Impact resistance, test severity level according to DIN IEC68; Part 2-27; IEC68-2-27-1987</b>								
Number of impacts	n	1000						
Duration	ms	3						
Acceleration (half-sine)	m/s <sup>2</sup>	650						
<b>Vibration resistance, test severity level according to DIN IEC 68, Part 2-6: IEC 68-2-6-1982</b>								
Frequency range	Hz	5...65						
Duration	h	1.5						
Acceleration (amplitude)	m/s <sup>2</sup>	50						
<b>Nominal (rated) speed</b>	rpm	12 000				10 000	8 000	
<b>Nominal (rated) speed optional</b>	rpm	22 000		18 000		14 000	12 000	

## Specifications (continued)

Nominal (rated) torque $M_{nom}$ for reference only	N·m	500	1 k	2 k	3 k	5 k	10 k
	ft-lb	375	750	1,500	2,250	3,750	7,500
<b>Load limit <sup>5)</sup></b>							
<b>Limit torque, relative to <math>M_{nom}</math></b>	%	200			160		
<b>Breaking torque, relative to <math>M_{nom}</math></b>	%	>400			>320		
<b>Longitudinal limit force</b>	kN	16	19	39	42	80	120
<b>Lateral limit force</b>	kN	4	5	9	10	12	18
<b>Bending limit moment</b>	Nm	200	220	560	600	800	1200
<b>Vibration bandwidth to DIN 50 100 (peak-to-peak)</b>	Nm	1000	2000	4000	4800	8000	16000
<b>Mechanical values</b>							
<b>Torsional stiffness <math>c_T</math></b>	kN·m/ rad	540	900	2300	2600	4600	7900
<b>Torsion angle at <math>M_{nom}</math></b>	degree	0.055	0.066	0.049	0.066	0.06	0.07
<b>Maximum excursion at longitudinal force limit</b>	mm	< 0.03		< 0.05		< 0.1	
<b>Additional max. concentric error at lateral force limit</b>	mm	< 0.01					
<b>Additional in-plane deviation at bending moment limit</b>	mm	< 0.04		< 0.06		< 0.09	
<b>Balance quality-level to DIN ISO 1940</b>		G 2.5					
<b>Max. limits for relative shaft vibration (peak-to-peak)<sup>6)</sup></b>	µm	$s_{max} = \frac{4500}{\sqrt{n}}$ (n in rpm)					
<b>Mass moment of inertia of the rotor</b>							
$I_V$ (about axis of rotation)	kg·m <sup>2</sup>	0.0059		0.0192	0.037	0.097	
$I_V$ with speed module	kg·m <sup>2</sup>	0.0061	0.0062	0.0196	0.0375	0.0976	
<b>Pro rata mass moment of inertia for transmitter side</b>							
without speed measuring system	%	57		55		54	
with speed measuring system	%	55		54		53	
<b>Max. permissible static eccentricity of the rotor (radially)</b>							
without speed module	mm	± 2					
with speed module	mm	± 1					
<b>Permissible axial displacement between rotor and stator</b>							
without speed module	mm	± 3					
with speed module	mm	± 2					

<sup>5)</sup> Each type of irregular stress (bending moment, lateral or longitudinal force, exceeding nominal (rated) torque) can only be permitted up to its specified static limit load provided none of the others can occur at the same time. If this condition is not met, the limit values must be reduced. If 30 % of the bending moment limit and lateral force limit occur at the same time, only 40 % of the longitudinal force limit is permissible and nominal (rated) torque must not be exceeded. The permissible bending moments, longitudinal forces and lateral forces can affect the measurement result by approx. 1 % of nominal (rated) torque.

<sup>6)</sup> Relative undulation in the connection flange range, following DIN 45670/VDI 2059





### 13 Supplementary technical information

#### 13.1 Output signals

##### 13.1.1 Output MD: torque (plug 1)

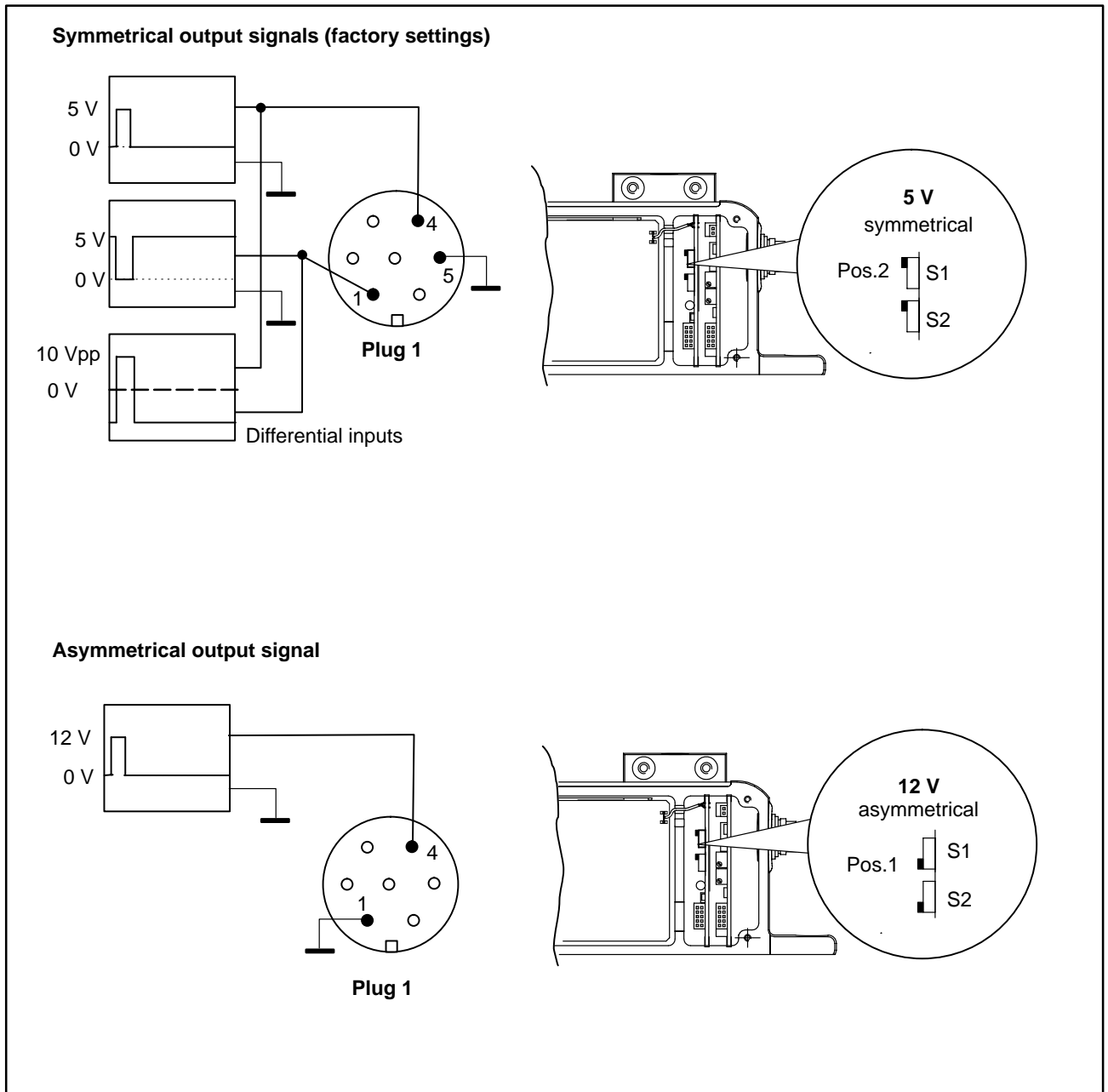

### 13.1.2 Output N: rotation speed and rotation speed with reference pulse (plug 2)

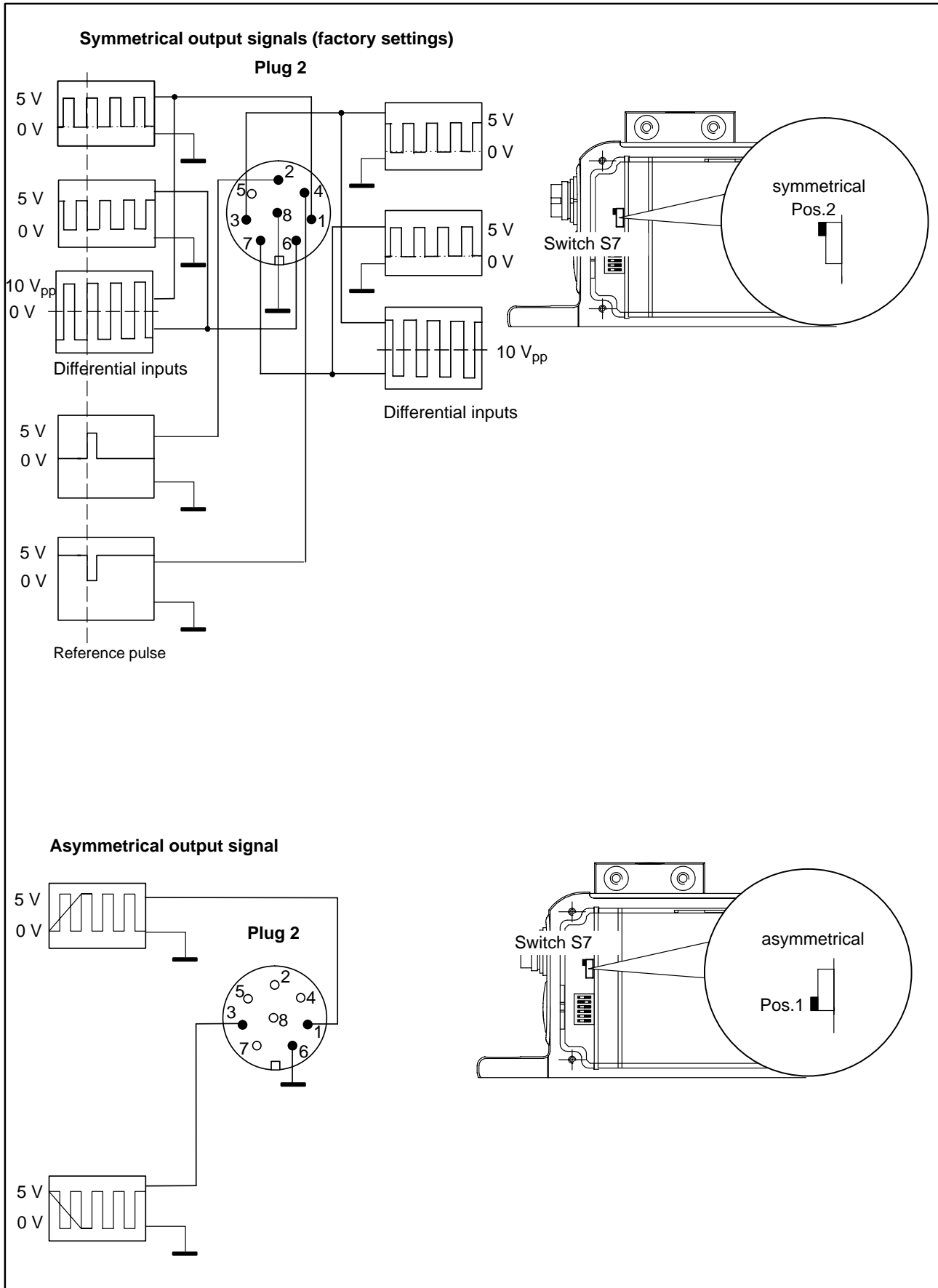

### 13.1.3 Plug 2, double frequency, stat. direction of rotation signal

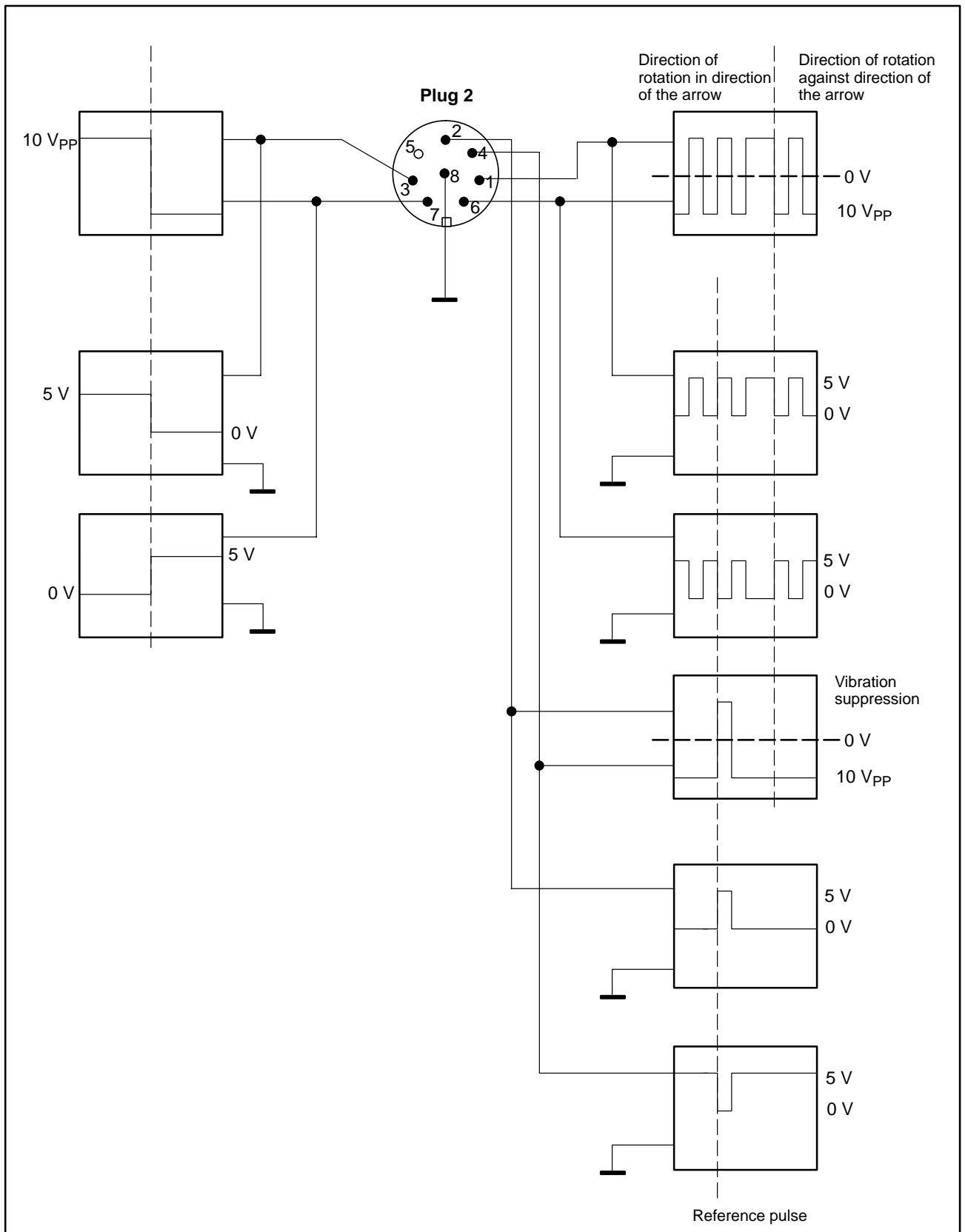

## 13.2 Run-out and concentric tolerances

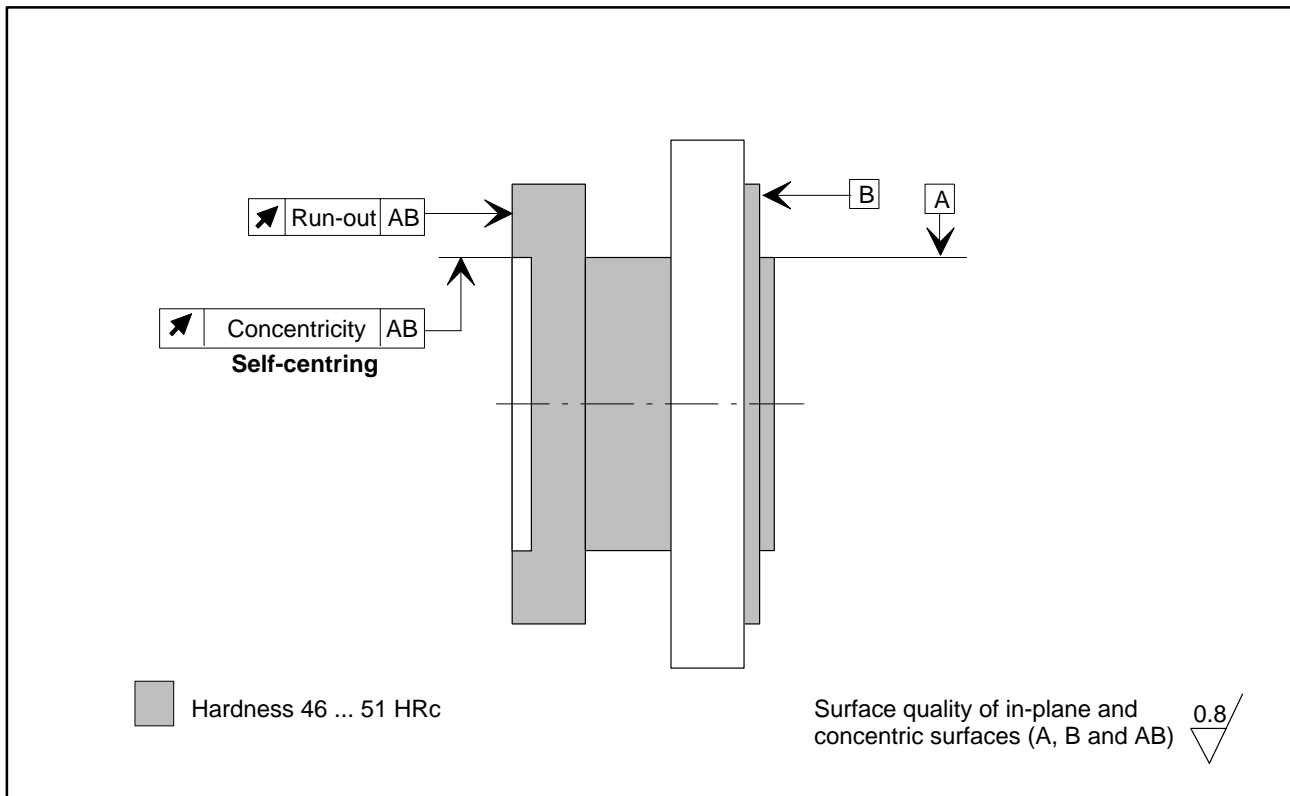

Measuring range	Run-out tolerance (mm)	Concentric tolerance (mm)
500 N·m	0.01	0.01
1 kN·m		
2 kN·m	0.02	0.02
3 kN·m		
5 kN·m	0.02	0.02
10 kN·m		

To maintain the features of the torque flange in the assembled state, we recommend to choose the specified tolerances for the form and position, the surface quality and hardness also for the connections on the customer's side.

## 13.3 Additional mechanical data

Noimnal (rated) torque $M_{nom}$	N·m	500	1 k	2 k	3 k	5 k	10 k
for reference only	ft-lb	375	750	1,500	2,250	3,750	7,500
Mechanical values							
Stiffness in the axial direction $c_a$	kN/mm	900	970	1000	1100	950	1600
Stiffness in the radial direction $c_r$	kN/mm	700	840	1400	1600	1400	2500
Stiffness during the bending moment round a radial axis $c_b$	kN·m/degree	9.5	9.8	21.7	22.4	31.4	71

## 14 Declaration of conformity



Hottinger Baldwin Messtechnik GmbH

Im Tiefen See 45 - D-64293 Darmstadt  
Tel. ++49/6151/803-0, Fax. ++49/6151/894896

### Konformitätserklärung

### Declaration of Conformity

### Déclaration de Conformité

Document: 145/01.2002

Wir,

We,

Nous,

**Hottinger Baldwin Messtechnik GmbH, Darmstadt**

erklären in alleiniger Verantwortung,  
dass das Produkt

declare under our sole  
responsibility that the product

déclarons sous notre seule  
responsabilité que le produit

#### **Drehmoment-Meßsystem T10FS**

auf das sich diese Erklärung  
bezieht, mit der/den folgenden  
Norm(en) oder normativen  
Dokument(en) übereinstimmt (siehe  
Seite 2) gemäß den Bestimmungen  
der Richtlinie(n)

to which this declaration relates is  
in conformity with the following  
standard(s) or other normative  
document(s) (see page 2)  
following the provisions of  
Directive(s)

auquel se réfère cette déclaration  
est conforme à la (aux) norme(s) ou  
autre(s) document(s) normatif(s)  
(voir page 2) conformément aux  
dispositions de(s) Directive(s)

89/336/EWG - Richtlinie des Rates vom 3. Mai 1989 zur Angleichung der Rechtsvorschriften der Mitgliedstaaten über die elektromagnetische Verträglichkeit, geändert durch 91/263/EWG, 92/31/EWG, 93/68/EWG und 93/97/EWG

Die Absicherung aller produkt-spezifischen Qualitätsmerkmale erfolgt auf Basis eines von der DQS (Deutsche Gesellschaft zur Zertifizierung von Managementsystemen) seit 1986 zertifizierten Qualitätsmanagementsystems nach DIN ISO 9001 (Reg. Nr. DQS-00001). Die Überprüfung der sicherheitsrelevanten Merkmale (Elektromagnetische Verträglichkeit, Sicherheit elektrischer Betriebsmittel) führt ein von der DATech erstmals 1991 akkreditiertes Prüflaboratorium (Reg. Nr. DAT-P-006 und DAT-P-012) unabhängig im Hause HBM durch.

All product-related features are secured by a quality system in accordance with DIN ISO 9001, certified by DQS (Deutsche Gesellschaft zur Zertifizierung von Managementsystemen) since 1986 (Reg. No. DQS-00001). The safety-relevant features (electromagnetic compatibility, safety of electrical apparatus) are verified at HBM by an independent testing laboratory which has been accredited by DATech in 1991 for the first time (Reg. Nos. DAT-P-006 and DAT-P-012).

Chez HBM, la détermination de tous les critères de qualité relatifs à un produit spécifique est faite sur la base d'un protocole DQS (Deutsche Gesellschaft zur Zertifizierung von Managementsystemen) certifiant, depuis 1986, notre système d'assurance qualité selon DIN ISO 9001 (Reg. Nr. DQS-00001). De même, tous les critères de protection électrique et de compatibilité électromagnétique sont certifiés par un laboratoire d'essais indépendant et accrédité depuis 1991 (Reg. Nr. DAT-P-006 et DAT-P-012).

Darmstadt, 2002-01-29

Dr. Michael Altwein

H. Fritz

Seite 2 zu

Page 2 of

Page 2 du

Document: 145/01.2002

Diese Erklärung bescheinigt die Übereinstimmung mit den genannten Richtlinien, beinhaltet jedoch keine Zusicherung von Eigenschaften.  
Die Sicherheitshinweise der mitgelieferten Produktdokumentation sind zu beachten.

Folgende Normen werden zum Nachweis der Übereinstimmung mit den Vorschriften der Richtlinie(n) eingehalten:

**EN 61326 : 1997  
+ A1 : 1998**

**Messbereiche:  
Optionen:  
weitere Optionen:**

**Elektrische Betriebsmittel für Leittechnik und Laboreinsatz** - EMV-Anforderungen;  
Deutsche Fassung

**500Nm, 1kNm, 2kNm, 3kNm, 5kNm, 10kNm  
SF1, SF2, SU1, KF1  
Drehzahlmeßsystem, Referenzimpuls**

This declaration certifies conformity with the Directives listed above, but is no asseveration of characteristics.  
Safety directions of the delivered product documentation have to be followed.

The following standards are fulfilled as proof of conformity with the provisions of the Directive(s):

Cette déclaration atteste la conformité avec les directives citées mais n'assure pas un certain caractère.  
S.v.p. observez les indications de sécurité de la documentation du produit ajoutée.

Pour la démonstration de la conformité aux disposition de(s) Directive(s) le produit satisfait les normes:



Modifications reserved.  
All details describe our products in general form only. They are not to be understood as express warranty and do not constitute any liability whatsoever.

**Hottinger Baldwin Messtechnik GmbH**

Postfach 10 01 51, D-64201 Darmstadt  
Im Tiefen See 45, D-64293 Darmstadt  
Tel.: +49/61 51/ 8 03-0; Fax: +49/61 51/ 8039100  
E-mail: [support@hbm.com](mailto:support@hbm.com) [www.hbm.com](http://www.hbm.com)



measurement with confidence