

3U VITA 62 VPX HOLD-UP MODULES

WHAT WE DO

PCI-SYSTEMS MANUFACTURES A VARIETY OF COTS MODULAR DESIGNED CONDUCTION COOLED CHASSIS FOR VPX AND CPCI APPLICATIONS, INCLUDING ATR AND ARINC 600 ENCLOSURES. OUR MISSION IS TO PROVIDE TECHNICALLY EXCELLENT DESIGN SOLUTIONS TO OEM'S BY DELIVERING THE MOST COST-EFFECTIVE, TECHNICALLY ADVANCED, AND RELIABLE/STABLE DESIGNS.

ISOLATED

GALVANIC ISOLATION IS ACHIEVED BY ISOLATING TWO CIRCUITS USING A TRANSFORMER. FOR MANY REASONS: SAFETY, NOISE IMMUNITY, CIRCUIT PROTECTION LIKE SHORT CIRCUIT PROTECTION.

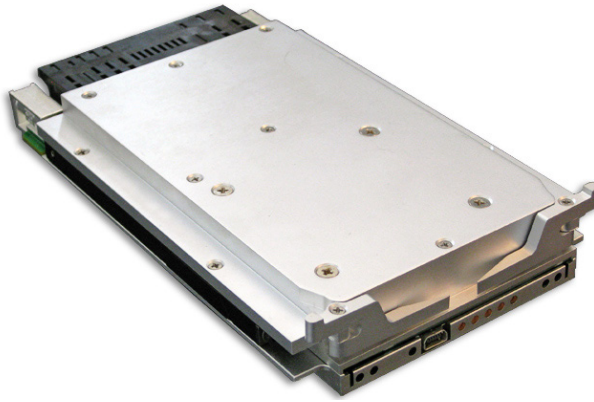

Features

- Downstream Mil-Std 704 protection
- Mil-Std 1275 compliance
- Reverse Polarity Protection
- SMART.PSU compatible
- 480ms @ 300W

3U VITA 62 HOLD-UP MODULE 28VDC 500W

This module is a +28VDC IN power conditioner with SUPERCAP holdup feature. It protects downstream DC-DC converters: Transients, low voltage conditions and power interruptions.

It provides up to 280 milliseconds of holdup time at full power. This module is built to meet MIL 810F and is conduction cooled.

DC Input	
Input	+28 VDC nominal
Input Discrete Signaling	One input discrete signal (short/open) provided to support configurable logic.
Input Transient Protection	MIL-STD-704A through F, optionally Mil-Std 1275AT
EMI	Per MIL-STD-461F
Reverse Polarity Protection	Will not be damaged when subjected to reverse DC polarity on the input
DC Output	
Main DC Output Power	Provides 20VDC to 30VDC @ 500 watts max. to the systems DC/DC Converters
Auxiliary DC Output Power	Provides standby output of 5VDC @ 0.5 amps
Holdup Time	300 watts of primary power for 480 milliseconds @ -40 to 65°C (380ms @ -40 to 85°C) 500 watts of primary power for 280 milliseconds @ -40 to 65°C (180ms @ -40 to 85°C)
Holdup cap charge time	8 seconds max.
Power Dissipation	6 Watts

3U VITA 62 VPX HOLD-UP MODULES

NO.WIRES

PCI-SYSTEMS CHASSIS

HIGHLY INTEGRATED REAR I/O

DESIGNS USES ZERO WIRES, ONLY

HIGH SPEED CONNECTORS AND

PRINTED CIRCUIT BOARDS

SWITCHED BACKPLANE PCIe GEN. 3

NO STUB DESIGNS ELIMINATE

BANDWIDTH DEGRADATION.

SWITCHES ARE DESIGNED AT

MID-PLANE ON THE BACKPLANE

BOARDS FOR SMALL PACKAGING

AND SUPERIOR SIGNAL QUALITY.

ASK FOR OUR

3D BACKPLANE

TECHNOLOGY BROCHURE!

WWW.PCISYSTEMS.COM

Signal Types	
Charged	Indicates holdup is charged and available. (Active low)
VIn OK	Indicates that the input voltage is between 20VDC and 30VDC. (Active low)
VOut OK	Indicates that the output voltage is between 20VDC and 30VDC. (Active low)
External On/Off	Connection to external closure available
Environmental	
Temperature Range	Operating: -40C to +85C at 100% load Storage: -55°C to +125°C
Reliability (MTBF)	200,000 hours, ground benign at 50°C cooling surface
Vibration, shock, Acceleration	Built to meet 810F
Enclosure	3U VITA 62 aluminum, nickel plated
Weight	720 Grams (1.6 pounds)

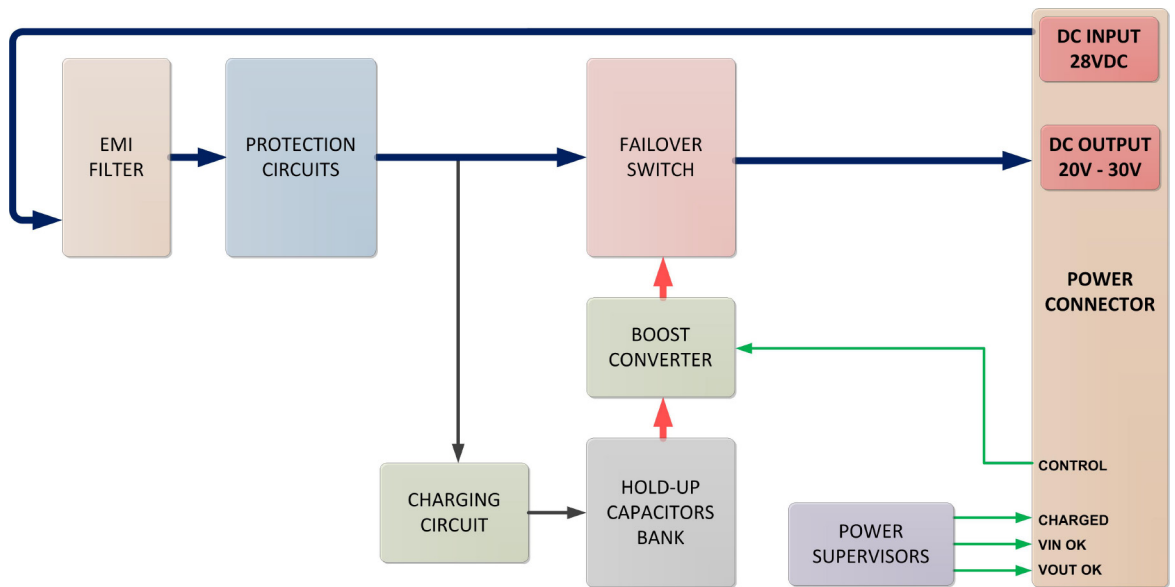

VITA 62 Power Supply Specification Ready - Featuring Tyco VITA 62 Connector 6450849-7. Please request the electrical ICD for this product for specific pin out information.



Ordering Information

PCI_800.401 -- 3U **VITA 83** VPX 500W input hold-up super cap 28V companion module

PCI_800.408 -- 3U **VITA 62** VPX 500W input hold-up super cap 28V companion module