

INTERNATIONAL STANDARD

ISO
9352

Second edition
1995-11-01

Plastics — Determination of resistance to wear by abrasive wheels

Plastiques — Détermination de la résistance à l'usure par galets abrasifs



Reference number
ISO 9352:1995(E)

Foreword

ISO (the International Organization for Standardization) is a worldwide federation of national standards bodies (ISO member bodies). The work of preparing International Standards is normally carried out through ISO technical committees. Each member body interested in a subject for which a technical committee has been established has the right to be represented on that committee. International organizations, governmental and non-governmental, in liaison with ISO, also take part in the work. ISO collaborates closely with the International Electrotechnical Commission (IEC) on all matters of electrotechnical standardization.

Draft International Standards adopted by the technical committees are circulated to the member bodies for voting. Publication as an International Standard requires approval by at least 75 % of the member bodies casting a vote.

International Standard ISO 9352 was prepared by Technical Committee ISO/TC 61, *Plastics*, Subcommittee SC 2, *Mechanical properties*.

This second edition cancels and replaces the first edition (ISO 9352:1989), of which it constitutes a minor revision.

Annex A forms an integral part of this International Standard.

© ISO 1995

All rights reserved. Unless otherwise specified, no part of this publication may be reproduced or utilized in any form or by any means, electronic or mechanical, including photocopying and microfilm, without permission in writing from the publisher.

International Organization for Standardization
Case postale 56 • CH-1211 Genève 20 • Switzerland

Plastics — Determination of resistance to wear by abrasive wheels

1 Scope

1.1 This International Standard specifies a general method for determining the resistance to abrasive wear of plastics under the action of abrasive wheels. It is equally applicable to moulded test specimens, components and finished products.

1.2 The particular test conditions and the method of expressing the results may differ according to the type of material. The test conditions and specific method are specified in the relevant standards for each material or product.

This method is not applicable to cellular materials or paints.

2 Normative references

The following standards contain provisions which, through reference in this text, constitute provisions of this International Standard. At the time of publication, the editions indicated were valid. All standards are subject to revision, and parties to agreements based on this International Standard are encouraged to investigate the possibility of applying the most recent editions of the standards listed below. Members of IEC and ISO maintain registers of currently valid International Standards.

ISO 48:1994, *Rubber, vulcanized or thermoplastic — Determination of hardness (hardness between 10 IRHD and 100 IRHD)*.

ISO 291:1977, *Plastics — Standard atmospheres for conditioning and testing*.

ISO 293:1986, *Plastics — Compression moulding test specimens of thermoplastic materials*.

ISO 294:1995, *Plastics — Injection moulding of test specimens of thermoplastic materials*.

ISO 295:1991, *Plastics — Compression moulding of test specimens of thermosetting materials*.

ISO 2818:1994, *Plastics — Preparation of test specimens by machining*.

ISO 6506:1981, *Metallic materials — Hardness test — Brinell test*.

ISO 6507-1:1982, *Metallic materials — Hardness test — Vickers test — Part 1: HV 5 to HV 100*.

3 Definitions

For the purposes of this International Standard, the following definitions apply.

3.1 abrasive wheel: A small grinding wheel or a roller faced with abrasive paper.

3.2 abrasive wear: The progressive loss of material from the operating surface of a plastic material resulting from the cutting or scratching action of the abrasive wheel.

4 Principle

Two abrasive wheels are applied to the test specimen with a specified load. The wear obtained after rotation of the test specimen through a specified number of revolutions is assessed by an appropriate procedure (e.g. mass loss, volume loss, change in optical properties, etc.).

5 Apparatus

5.1 Abrasion test machine

The test specimen is placed on a motor-driven rotating disc. A pair of abrasive wheels are allowed to turn freely on their axis and are applied to the test specimen at a specified position under a specified load. Figure 1 illustrates the relative positions of these different components. The apparatus shall comply with the following requirements:

5.1.1 The test specimen support disc shall be flat and fixed to its driving shaft. When the disc is rotated, no point on a 45 mm radius circle traced on its horizontal surface shall oscillate vertically through more than 0,05 mm about its mean position. The disc shall have a nominal diameter of 100 mm and its speed of rotation shall be 72 rev/min at 60 Hz and 60 rev/min at 50 Hz

5.1.2 The abrasive wheels shall be supported by two symmetrical arms that can oscillate freely about a horizontal axis. The method of attaching the wheels shall permit free rotation, e.g. by means of ball bearings. In the test position, the mounting bosses shall be coaxial and positioned in such a way that the vertical projection of their common axis on to the plane of the test specimen support disc is 19,1 mm \pm 0,1 mm from a parallel line passing through the axis of the disc (see figure 1).

The distance between the inside faces of the abrasive wheels shall be 52,4 mm \pm 0,2 mm.

Each arm shall be constructed in such a way as to permit the fitting of a counterweight to balance its mass against that of the abrasive wheel and additional loads of known mass (see 5.4).

5.1.3 The abrasive wheels shall have a cylindrical shape. They shall contain an axial hole allowing them

to be fitted without play to the mounting bosses in the arms.

They shall consist of one of the following two alternatives:

- an abrasive material (abrasive wheels). The thickness of the wheels shall be 12,7 mm \pm 0,1 mm and their external diameter 51,6 mm \pm 0,1 mm when new, but in no case less than 44,4 mm,
- a metal disc with its periphery clad with a 6 mm layer of vulcanized rubber of hardness 50 IRHD to 55 IRHD (international hardness in accordance with ISO 48) bonded without gaps or overlap with a strip of abrasive paper (for example, secured with the aid of double-sided adhesive tape). The abrasive wheel shall have a thickness of 12,7 mm \pm 0,2 mm and a diameter of 51,6 mm \pm 0,2 mm. The width of the abrasive paper shall be as specified in the relevant material (or product) standard.

The quality of the abrasive wheel or abrasive paper to be used shall be as stated in each relevant material (or product) specification. Refer to table 1 for guidance in selecting suitable abrasive wheels. The abrasive-power properties of the wheels may be characterized, if requested, by the procedure given in annex A.

Table 1 — Abrasive wheel selection chart

Series designation	Wheel type	Composition	Recommended load range	Abrasive action	Approximate grit size (No. of abrasive particles/cm ²)
			N		
CS10	Resilient	Rubber and abrasive grain	4,9 to 9,8	Mild	1 420
CS10F	Resilient	Rubber and abrasive grain	2,5 to 4,9	Very mild	1 420
CS17	Resilient	Rubber and abrasive grain	4,9 to 9,8	Harsh	645
H10	Non-resilient	Vitrified	4,9 to 9,8	Coarse	1 160
H18	Non-resilient	Vitrified	4,9 to 9,8	Medium coarse	1 160
H22	Non-resilient	Vitrified	4,9 to 9,8	Very coarse	515
H38	Non-resilient	Vitrified	2,5; 4,9; 9,8	Very coarse Hard	5 785

NOTES

- Under normal conditions, the "CS" series wheels shall be used when testing a flexible specimen, the "H" series wheels shall be used for testing rigid specimens.
- CS10F wheels are subject to deterioration due to ageing of the rubber, especially in high-ozone atmospheres. It is therefore important to use these wheels before the expiration date on the wheel.
- When refacing (see 8.10), the recommended number of rotations for CS10, CS10F and CS17 wheels is 25 to 50.
- Results from two different wheels, even of the same type, may not always be comparable.

Dimensions in millimetres

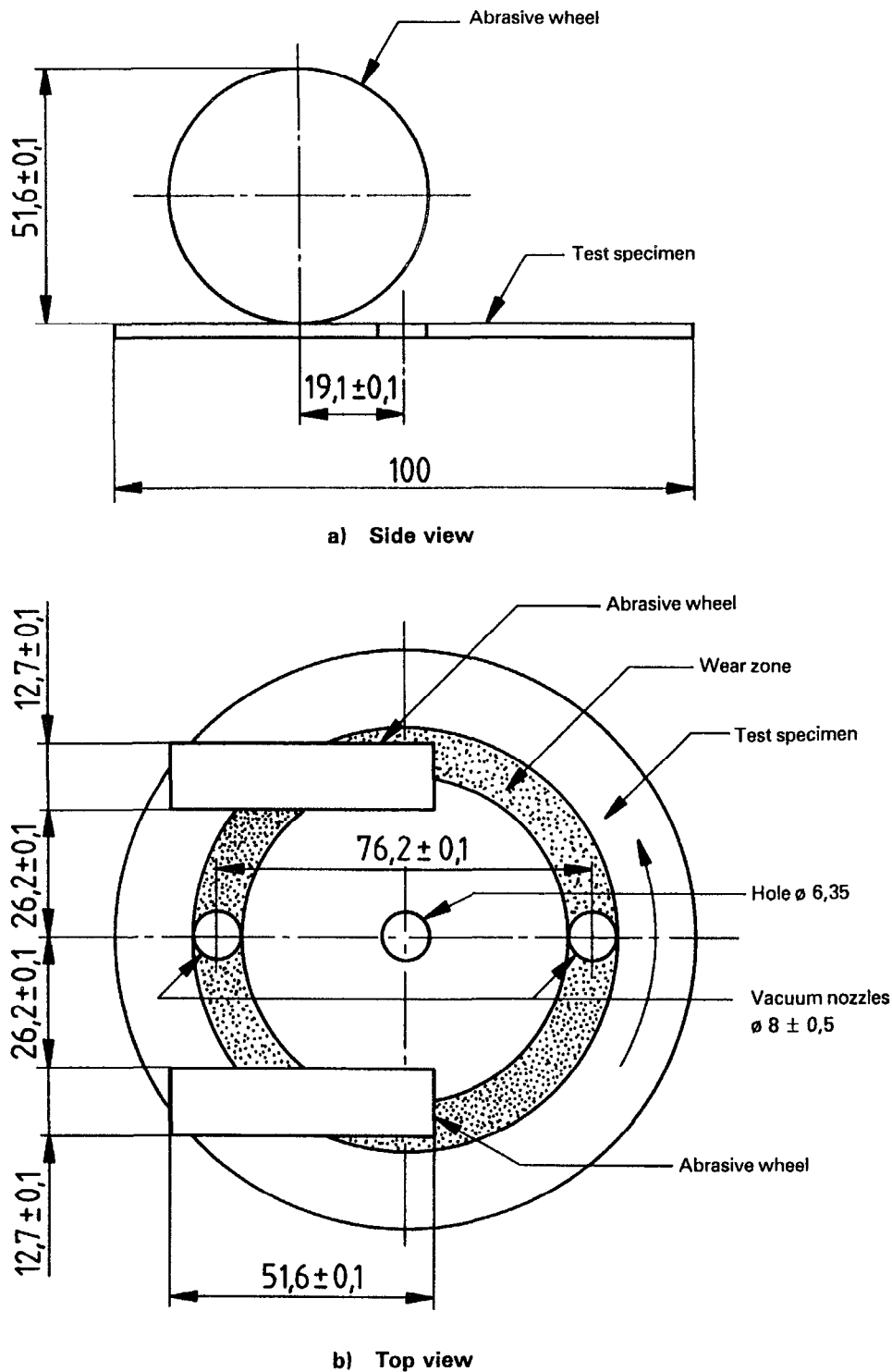

Figure 1 — Diagrammatic arrangement of apparatus

5.1.4 The vacuum device for removal of the wear debris shall include two exhaust nozzles above the test specimen wear zone. One nozzle shall be located between the abrasive wheels and the other shall be located diametrically opposite (see figure 1). The bore of each nozzle shall have an internal diameter of $8 \text{ mm} \pm 0,5 \text{ mm}$ and its distance from the test specimen shall be maintained at $1,5 \text{ mm} \pm 0,5 \text{ mm}$. When the nozzles are blocked closed, the pressure shall be $1,5 \text{ kPa}$ to $1,6 \text{ kPa}$

5.1.5 The apparatus shall be equipped with a device enabling the test to be stopped after a predetermined number of revolutions of the rotating disc.

5.1.6 For testing thin specimens, or flexible plastics, the apparatus shall be equipped with a clamp ring to enable such specimens to be fitted on to the support disc

5.2 Conditioning enclosure, permitting the maintenance of an atmosphere of $23 \text{ }^\circ\text{C} \pm 2 \text{ }^\circ\text{C}$ and $(50 \pm 5) \%$ relative humidity, in accordance with ISO 291.

5.3 Standard zinc plates, for calibrating the abrasive power of the wheels (see annex A)

5.4 Additional masses, for loading each abrasive wheel to the requirements of the relevant material (or product) specification

5.5 Apparatus for refacing the abrasive wheels, permitting the elimination of all refuse and at the same time assuring perpendicular contact between the specimen and the wheel

5.6 Equipment for assessing the wear, in accordance with the relevant material (or product) specification

6 Test specimens

6.1 Shape and dimensions

The test specimens shall be

- either discs of nominal diameter 100 mm ,
- or octagons obtained by cutting off the corners of squares of nominal side length 100 mm , when the use of the clamp ring (see 5.1.6) is not necessary.

Their thickness shall be uniform and between $0,5 \text{ mm}$ and 10 mm

6.2 Preparation of test specimens

Test specimens may be obtained by moulding in accordance with ISO 293, ISO 294 or ISO 295, or by machining in accordance with ISO 2818. Each speci-

men shall contain a $6,35 \text{ mm}$ diameter centre hole to accommodate the stud of the rotating disc

6.3 Cleaning of test specimens

The test specimen surface shall be cleaned with the aid of a suitable neutral volatile solvent or mild soap solution, selected in accordance with the requirements of the relevant material (or product) specification or by agreement between the interested parties

WARNING — Use of a cleaner (however volatile) may affect abrasion characteristics.

6.4 Number of test specimens

The number of test specimens shall be as stated in the relevant material (or product) specification. In the absence of any such indication, the minimum number shall be three.

7 Conditioning of test specimens

The test specimens shall be conditioned in the enclosure (5.2) in accordance with the requirements of the relevant material (or product) specification or, in the absence of such requirements, for a duration of at least 48 h before test.

NOTE 1 Certain specifications also specify the conditioning of the abrasive wheel or abrasive paper

8 Procedure

8.1 The test shall be performed in the enclosure (5.2) of an environmentally controlled room having the same characteristics.

8.2 For each test specimen, perform the preliminary measurements specified by the relevant material (or product) specification (see the warning in 8.3)

8.3 Fit the test specimen to the specimen carrier disc

WARNING — During the course of the operations described in 8.2 and 8.3, take care not to contaminate the surface to be tested, e.g. with oil from finger contact.

8.4 Fit the apparatus with the abrasive wheels (see 5.1.3) specified by the relevant material (or product) specification, carefully avoiding touching the cylindrical abrasive zone. Lower the arms and gently place the abrasive wheels on the test specimen.

The abrasive power of the wheels (abrasive wheels or abrasive paper) may be verified in accordance with the procedure given in annex A. In the case of abrasive wheels, this operation shall be followed by refacing using the refacing apparatus (5.5).

8.5 Adjust the loading of each abrasive wheel to the value specified in the relevant material (or product) specification, using the counterweights and additional masses (5.4).

8.6 Adjust the position of the vacuum device (see 5.1.4).

8.7 Set the number of revolutions to the value specified by the relevant material (or product) specification, or as agreed between the interested parties, using the device provided (see 5.1.5) (see also note 2 below).

8.8 Start the motor driving the rotation of the test specimen and the vacuum system (see 5.1.4).

8.9 When the stipulated number of revolutions has been completed and the motor stopped, remove the test specimen and perform the final measurements specified in the relevant material (or product) specification.

NOTE 2 Certain specifications do not specify a fixed number of revolutions but they require periodic examination of the worn surface, the test being terminated when a defined threshold of degradation is reached.

8.10 In cases where grinding wheels are used, they shall be refaced before each test with the aid of the refacing apparatus (5.5) in such a way that the abrasive surface is exactly cylindrical and that the edges between the abrasive surface and the side faces are sharp, without any blending radius.

In cases where discs with abrasive paper are used, the abrasive paper shall be replaced after 500 revolutions or when clogging or loss of abrasive occurs. Clogging of the abrasive paper is dependent upon the test specimen material. With a soft, wax-like material, inspect the abrasive paper every 25 revolutions. In all other cases, inspect the abrasive paper every 50 revolutions or 100 revolutions.

Abrasive wheels are less susceptible to clogging and shall be inspected every 50 revolutions to 100 revolutions (cleaned with a wire brush when needed).

9 Expression of results

The results shall be expressed in one of the following ways:

a) as the change in a particular property after a defined number of revolutions, for example change in thickness, mass, luminous diffusion; in this case, calculate the mean value for the test specimens tested;

- b) as the number of revolutions required to obtain a defined deterioration in appearance; in this case, round the value obtained to the nearest multiple of 25 revolutions;
- c) as the loss in mass, in kilograms per thousand revolutions, for tests performed under a specific set of conditions on materials of similar density,
- d) as the loss in volume, in cubic millimetres per thousand revolutions, when comparing materials of different densities.

10 Precision

The precision of this test method is not known because interlaboratory data are not available. It should be recognized that the precision of the method will depend upon the procedure used to assess abrasive wear; different results are to be expected when evaluating mass loss, volume loss, changes in optical properties, etc. This method may not be suitable for use in specifications or in case of disputed results as long as interlaboratory data are not available.

11 Test report

The test report shall include the following particulars:

- a) a reference to this International Standard and to the relevant material (or product) specification if it exists;
- b) complete details of the material or product tested;
- c) complete details of the abrasive used (abrasive wheel or paper) and, if determined, its abrasive power as measured under the conditions described in annex A,
- d) the method of cleaning the test specimen surface;
- e) the load applied to each abrasive wheel,
- f) the number of revolutions set (when the test result is not itself expressed as a number of revolutions),
- g) the value of each individual determination, the mean value, and the method by which the wear was assessed;
- h) all other details of the test (changing of the abrasive paper, cleaning, conditioning, etc.).

Annex A (normative)

Determination of the abrasive power of the abrasive wheels

The abrasive power of the abrasive wheels shall be determined under the conditions defined in the relevant material (or product) specification. It is characterized by the loss in mass of a reference standard zinc plate after a specified number of revolutions.

A.1 Reference test specimen

The reference test specimen shall be prepared from a sheet of pure zinc (purity at least 99 %), with a thickness of 0,7 mm to 0,8 mm, pre-treated at 200 °C for 60 min.

The Vickers hardness of the surface of this sheet, measured in accordance with ISO 6507-1, shall be $42 \text{ HV } 100 \pm 2 \text{ HV } 100$, or the equivalent Brinell hardness value measured in accordance with ISO 6506.

A.2 Procedure

Clean the reference test specimen with acetone, weigh it to the nearest 1 mg, then subject it to the test in accordance with the procedure described in clause 8. The applied load and the number of revolutions shall be as specified in the relevant material (or

product) standard. In the absence of any such instructions, use a load of 4,9 N and 1 000 revolutions

After the test, weigh the specimen again to the nearest 1 mg.

A.3 Expression of results

The abrasive power of the wheels used (abrasive wheels or abrasive paper) shall be characterized by the loss, calculated for 1 000 revolutions, in mass or volume, or as specified in the relevant material (or product) specification.

A.4 Frequency of calibration

A.4.1 In the case of abrasive wheels, it is recommended that the wheels be calibrated on receipt and that this procedure be repeated every 3 months. After each calibration, the wheels shall be refaced before the first test.

A.4.2 In the case of abrasive paper, calibration shall be performed on a representative sample and the first test shall be performed on a fresh (unused) portion of the abrasive paper. It is recommended that the paper be calibrated on receipt and that the procedure be repeated every 3 months, or as specified in the relevant material (or product) specification.

ICS 83.080

Descriptors: plastics, tests, wear tests, abrasive tests, determination, wear resistance, abrasion resistance, test equipment, test specimens

Price based on 6 pages
