

GDL
GDLS
GDL-B
GDLS-B

GDL、GDLS、GDL-B、GDLS-B系列

立式管道多级离心泵

L I S H I G U A N D A O D U O J I L I X I B E N G

使用说明书



上海协晋泵业有限公司
ShangHai XieJin Pumps CO.,LTD.

产品概述

GDL 型多级管道离心泵是我单位在国内外优秀泵型之基础上结合用户的使用要求及消防有关标准，并根据 JB / TQ6435-92 标准设计制造的新一代产品。

本型泵采用立式节段式外加不锈钢壳体结构，使得泵的进出口位于同一水平线上且口径相同，能象阀门一样安装于管路之中，它同时集中了多级泵之高压，立式泵之占地面积小及管道泵之安装方便的优点，同时由于采用了优秀的水力模型，所以还具有高效节能，运行平稳等优点，且轴封采用耐磨机械密封，无泄漏使用寿命长。

为了能更好地满足用户的要求，本单位还开发了出水口位于上部的 GDLS 型，其进出口可以不同的相对位置(0°、90°、180°)安装，使用极为方便。

为了使用户能更加安全、可靠的使用该型泵，本单位特别研制了便拆式结构型，它除拥有 GDL、GDLS 的一切优点外，更为您更换机械密封等易损件提供了更加方便，快捷、省力的途径，使本型泵更无忧运行与维护。

应用范围

本型泵主要适用于高压运行系统中冷热清水的循环和增压、高层建筑多台泵并联供水、消防、锅炉给水和冷却水系统及各种冲洗液的输送等。

工作条件

1. 本型泵可输送清水或物理化学性质类似于清水的液体；
2. 液体温度：-15℃~+120℃；
3. 工作压力：最大工作压力<2.5MPa，即系统压力=入口压力+闭阀工作时的压力<2.5MPa；
4. 周围环境的温度应低于 40℃，相对湿度不超过 95%；
5. 输送含腐蚀性介质及热液体时，请于订货时提出，以便采用特殊材质满足使用要求。

☆ 型号意义

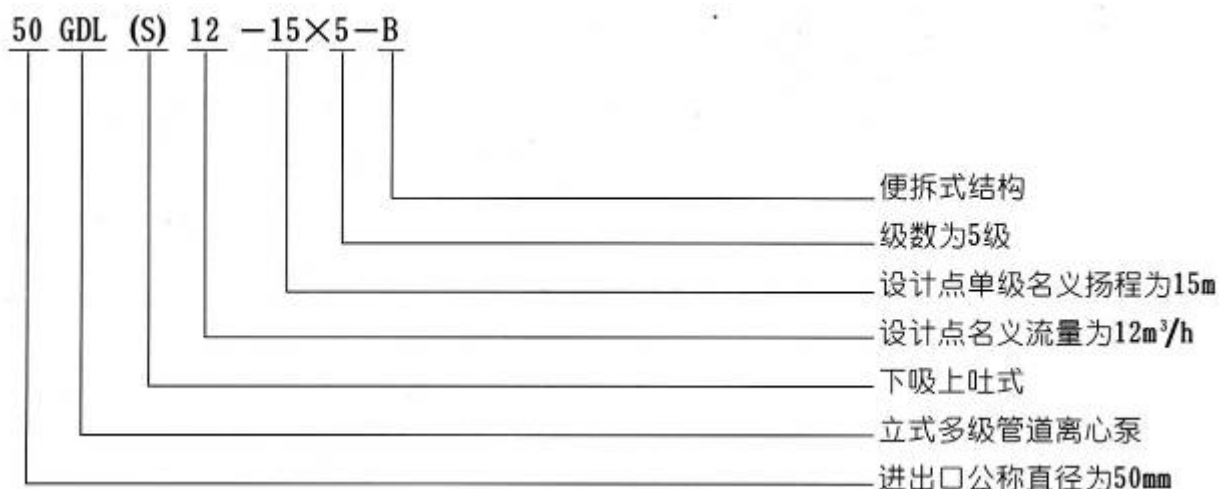

☆ 结构简图

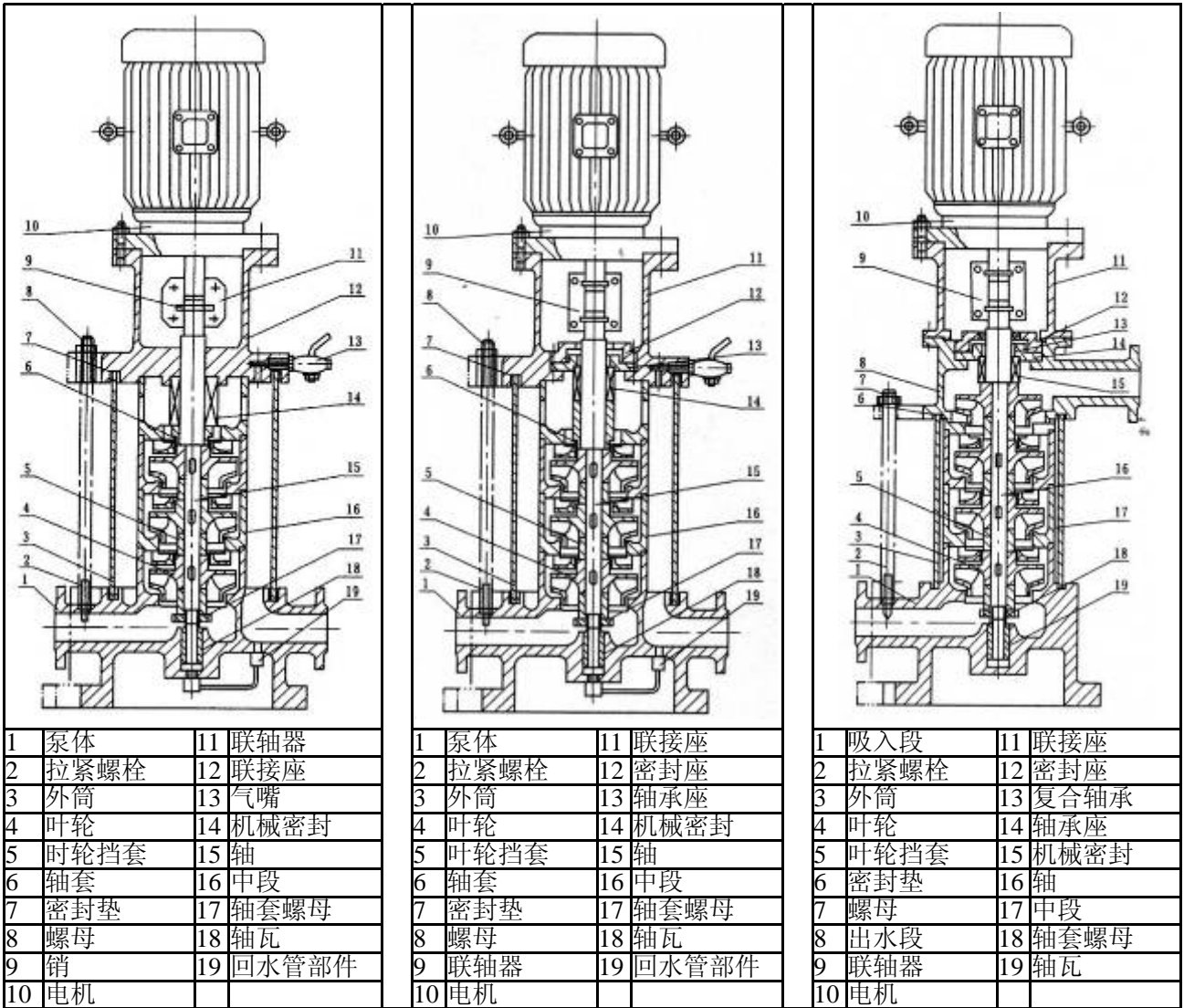

☆ 型谱图

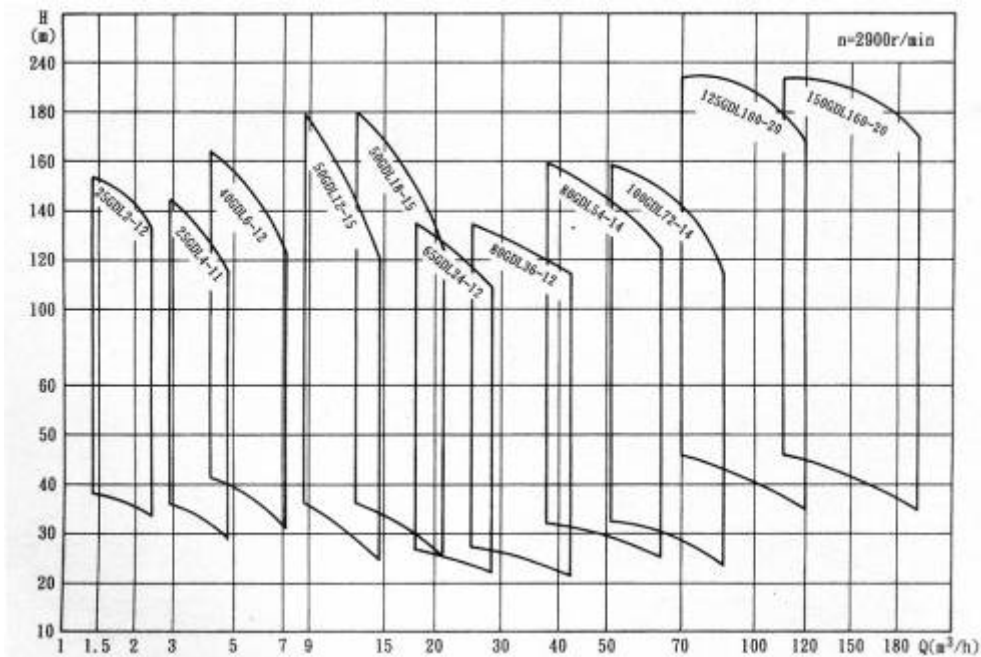

☆ 性能曲线图

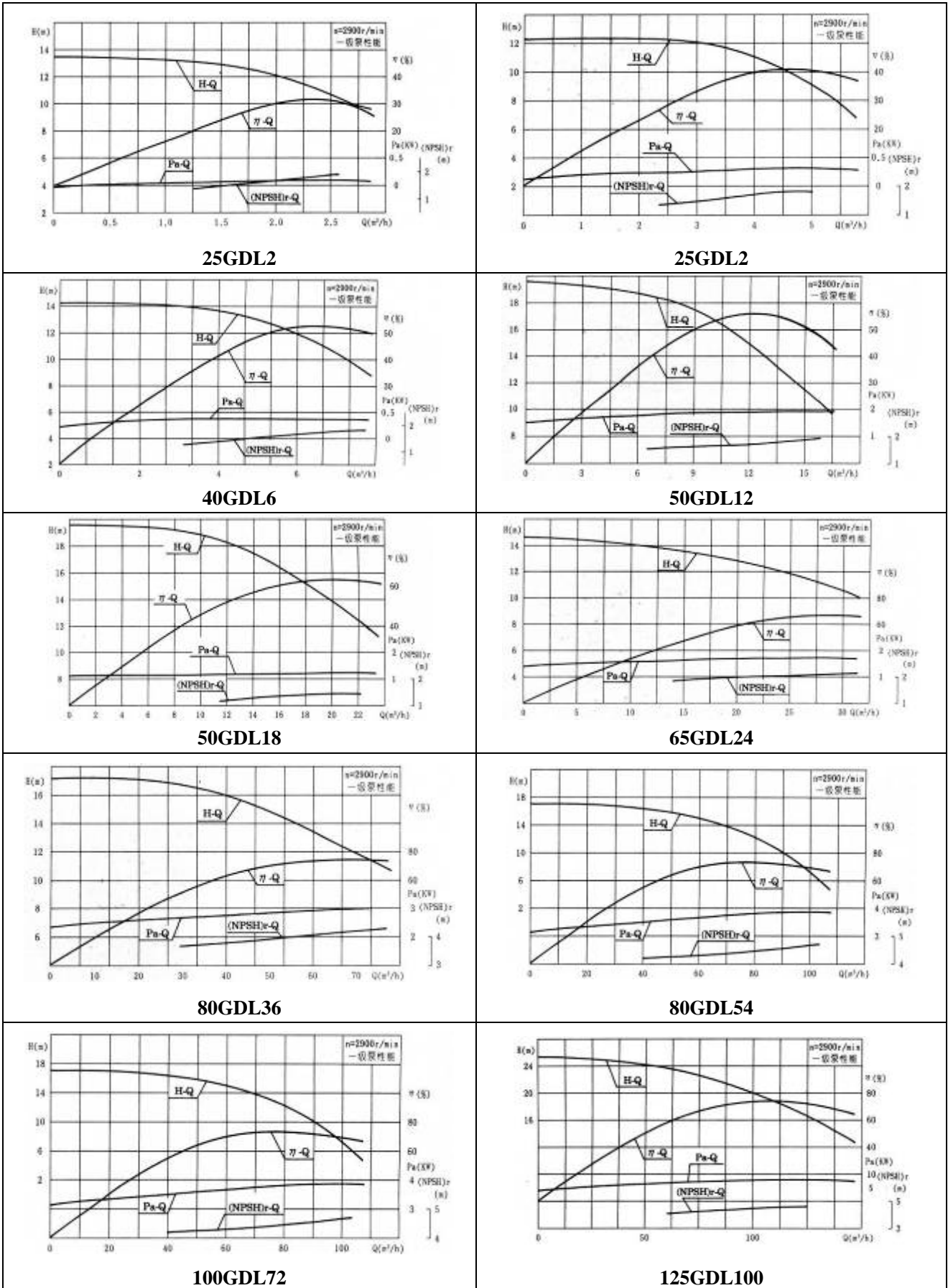

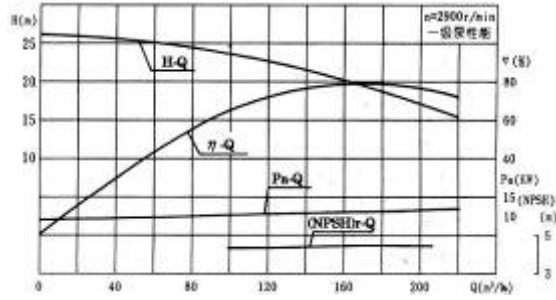

150GDL-160

☆性能参数表

型号	流量		扬程 (m)	效率 (%)	转速 (r/min)	功率(KW)		汽蚀 余量 (m)	进出 口径 (mm)	高度 H (m)	重量 (kg)	高度 h1 (m)
	(m³/h)	(L/S)				轴功率	电机功 率					
25GDL2-12×3	1.4	0.39	38	23	2900	0.63	1.1	1.4	25	606	58	125
	2	0.56	36	30		0.65		1.7				
	2.4	0.67	33	32		0.67		1.8				
25GDL2-12×4	1.4	0.39	50	23	2900	0.83	1.1	1.4	25	646	62	165
	2	0.56	48	30		0.87		1.7				
	2.4	0.67	44	32		0.90		1.8				
25GDL2-12×5	1.4	0.39	63	23	2900	1.04	1.5	1.4	25	711	68	205
	2	0.56	60	30		1.09		1.7				
	2.4	0.67	55	32		1.12		1.8				
25GDL2-12×6	1.4	0.39	76	23	2900	1.26	1.5	1.4	25	751	72	245
	2	0.56	72	30		1.30		1.7				
	2.4	0.67	66	32		1.35		1.8				
25GDL2-12×7	1.4	0.39	88	23	2900	1.46	2.2	1.4	25	816	78	285
	2	0.56	84	30		1.52		1.7				
	2.4	0.67	77	32		1.57		1.8				
25GDL2-12×8	1.4	0.39	101	23	2900	1.63	2.2	1.4	25	856	82	325
	2	0.56	96	30		1.74		1.7				
	2.4	0.67	88	32		1.80		1.8				
25GDL2-12×9	1.4	0.39	114	23	2900	1.89	2.2	1.4	25	896	86	365
	2	0.56	108	30		1.96		1.7				
	2.4	0.67	99	32		2.02		1.8				
25GDL2-12×10	1.4	0.39	126	23	2900	2.01	3	1.4	25	981	98	405
	2	0.56	120	30		2.17		1.7				
	2.4	0.67	110	32		2.24		1.8				
25GDL2-12×11	1.4	0.39	139	23	2900	2.31	3	1.4	25	1021	102	445
	2	0.56	132	30		2.39		1.7				
	2.4	0.67	121	32		2.47		1.8				
25GDL2-12×12	1.4	0.39	152	23	2900	2.52	3	1.4	25	1061	106	485
	2	0.56	144	30		2.61		1.7				
	2.4	0.67	132	32		2.70		1.8				

25GDL4-11×3	2.8	0.78	36	32	2900	0.86	1.1	1.4	25	606	58	125
	4	1.11	33	40		0.90		1.7				
	4.8	1.33	28.5	41		0.91		1.8				
25GDL4-11×4	2.8	0.78	48	32	2900	1.14	1.5	1.4	25	671	65	165
	4	1.11	44	40		1.20		1.7				
	4.8	1.33	38	41		1.21		1.8				
25GDL4-11×5	2.8	0.78	60	32	2900	1.43	2.2	1.4	25	736	72	205
	4	1.11	55	40		1.50		1.7				
	4.8	1.33	47.5	41		1.51		1.8				
25GDL4-11×6	2.8	0.78	72	32	2900	1.72	2.2	1.4	25	776	76	245
	4	1.11	66	40		1.80		1.7				
	4.8	1.33	57	41		1.82		1.8				
25GDL4-11×7	2.8	0.78	84	32	2900	2.00	3	1.4	25	861	86	285
	4	1.11	77	40		2.10		1.7				
	4.8	1.33	66.5	41		2.12		1.8				
25GDL4-11×8	2.8	0.78	96	32	2900	2.29	3	1.4	25	901	90	325
	4	1.11	88	40		2.40		1.7				
	4.8	1.33	76	41		2.42		1.8				
25GDL4-11×9	2.8	0.78	108	32	2900	2.57	3	1.4	25	941	94	365
	4	1.11	99	40		2.70		1.7				
	4.8	1.33	85.5	41		2.73		1.8				
25GDL4-11×10	2.8	0.78	120	32	2900	2.86	4	1.4	25	1011	110	405
	4	1.11	110	40		3.00		1.7				
	4.8	1.33	95	41		3.03		1.8				
25GDL4-11×11	2.8	0.78	132	32	2900	3.14	4	1.4	25	1051	114	445
	4	1.11	121	40		3.30		1.7				
	4.8	1.33	104.5	41		3.33		1.8				
25GDL4-11×12	2.8	0.78	144	32	2900	3.43	4	1.4	25	1091	118	485
	4	1.11	132	40		3.60		1.7				
	4.8	1.33	114	41		3.64		1.8				
25GDL4-11×13	2.8	0.78	156	32	2900	3.72	4	1.4	25	1131	122	525
	4	1.11	143	40		3.90		1.7				
	4.8	1.33	123.5	41		3.94		1.8				

注:1: GDLS、GDL-B、GDLS-B 型除重量 H 尺寸稍有不同外其性能参数与 GDL 型相同。

2:h1 尺寸仅用于 GDLS 及 GDLS-B

型号	流量		扬程 (m)	效率 (%)	转速 (r/min)	功率(KW)		汽蚀 余量 (m)	进出 口径 (mm)	高度 H (mm)	重量 (kg)	高度 h1 (m)
	(m ³ /h)	(L/s)				轴功率	电机功 率					
40GDL6-12×3	4.2	1.17	41	43	2900	1.09	1.5	1.4	40	657	72	125
	6	1.67	36	52		1.13		1.7				
	7.2	2.0	30.5	52		1.15		1.8				
40GDL6-12×4	4.2	1.17	54	43	2900	1.45	2.2	1.4	40	722	78	165
	6	1.67	48	52		1.5		1.7				
	7.2	2.0	40.6	52		1.53		1.8				
40GDL6-12×5	4.2	1.17	68	43	2900	1.81	2.2	1.4	40	762	82	205
	6	1.67	60	52		1.88		1.7				
	7.2	2.0	51	52		1.92		1.8				
40GDL6-12×6	4.2	1.17	82	43	2900	2.18	3	1.4	40	847	92	245
	6	1.67	72	52		2.26		1.7				
	7.2	2.0	61	52		2.30		1.8				
40GDL6-12×7	4.2	1.17	95	43	2900	2.54	3	1.4	40	887	96w	285
	6	1.67	84	52		2.64		1.7				
	7.2	2.0	71	52		2.69		1.8				
40GDL6-12×8	4.2	1.17	109	43	2900	2.91	4	1.4	40	967	112	325
	6	1.67	96	52		3.01		1.7				
	7.2	2.0	81	52		3.07		1.8				
40GDL6-12×9	4.2	1.17	123	43	2900	2.27	4	1.4	40	1007	116	365
	6	1.67	108	52		3.39		1.7				
	7.2	2.0	91	52		3.45		1.8				
40GDL6-12×10	4.2	1.17	136	43	2900	3.63	4	1.4	40	1047	120	405
	6	1.67	120	52		3.77		1.7				
	7.2	2.0	102	52		3.84		1.8				
40GDL6-12×11	4.2	1.17	150	43	2900	4.0	5.5	1.4	40	1132	140	445
	6	1.67	132	52		4.15		1.7				
	7.2	2.0	112	52		4.22		1.8				
40GDL6-12×12	4.2	1.17	164	43	2900	4.36	5.5	1.4	40	1172	146	485
	6	1.67	144	52		4.52		1.7				
	7.2	2.0	122	52		4.60		1.8				
50GDL12-15×2	8.4	2.33	36	48	2900	1.72	2.2	1.4	50	766	113	158
	12	3.33	30	56		1.75		1.8				
	14.4	4.0	24	53		1.85		1.8				
50GDL12-15×3	8.4	2.33	54	48	2900	2.57	3	1.4	50	866	129	233
	12	3.33	45	56		2.63		1.8				
	14.4	4.0	36	53		2.78		1.8				
50GDL12-15×4	8.4	2.33	72	48	2900	3.43	4	1.4	50	1001	149	308
	12	3.33	60	56		3.5		1.8				
	14.4	4.0	48	53		3.70		1.8				
50GDL12-15×5	8.4	2.33	90	48	2900	4.2	5.5	1.4	50	1126	181	383
	12	3.33	75	56		4.27		1.8				
	14.4	4.0	60	53		4.63		1.8				

50GDL12-15×6	8.4	2.33	108	48	2900	5.15	5.5	1.4	50	1201	190	458
	12	3.33	90	56		5.25		1.8				
	14.4	4.0	72	53		5.55		1.8				
50GDL12-15×7	8.4	2.33	126	48	2900	6.0	7.5	1.4	50	1276	204	533
	12	3.33	105	56		6.12		1.8				
	14.4	4.0	84	53		6.48		1.8				
50GDL12-15×8	8.4	2.33	144	48	2900	6.86	7.5	1.4	50	1351	212	608
	12	3.33	120	56		7.0		1.8				
	14.4	4.0	96	53		7.40		1.8				
50GDL12-15×9	8.4	2.33	162	48	2900	7.72	11	1.4	50	1556	265	683
	12	3.33	135	56		7.87		1.8				
	14.4	4.0	108	53		8.33		1.8				
50GDL12-15×10	8.4	2.33	180	48	2900	8.58	11	1.4	50	1631	273	758
	12	3.33	150	56		8.75		1.8				
	14.4	4.0	120	53		9.25		1.8				
50GDL18-15×2	12.6	3.5	36	53	2900	2.33	3	1.4	50	791	122	158
	18	b	30	62		2.37		1.8				
	21.6	6	25	62		2.37		1.8				
50GDL18-15×3	12.6	3.5	54	53	2900	3.5	4	1.4	50	926	142	233
	18	5	45	62		3.56		1.8				
	21.6	6	37.5	62		3.56		1.8				
50GDL18-15×4	12.6	3.5	72	53	2900	4.66	5.5	1.4	50	1051	175	308
	18	5	60	62		4.75		1.8				
	21.6	6	50	62		4.75		1.8				
50GDL18-15×5	12.6	3.5	90	53	2900	5.83	7.5	1.4	50	1126	189	383
	18	5	75	62		5.93		1.8				
	21.6	6	62.5	62		5.93		1.8				
50GDL18-15×6	12.6	3.5	108	53	2900	7.0	7.5	1.4	50	1201	198	458
	18	5	90	62		7.12		1.8				
	21.6	6	75	62		7.12		1.8				
50GDL18-15×7	12.6	3.5	126	53	2900	8.16	11	1.4	50	1406	252	533
	18	5	105	62		8.30		1.8				
	21.6	6	82.5	62		8.31		1.8				
50GDL18-15×8	12.6	3.5	144	53	2900	9.32	11	1.4	50	1481	261	608
	18	5	120	62		9.49		1.8				
	21.6	6	100	62		9.49		1.8				
50GDL18-15×9	12.6	3.5	162	53	2900	10.49	15	1.4	50	1556	280	683
	18	5	135	62		10.68		1.8				
	21.6	6	112.5	62		10.68		1.8				
50GDL18-15×10	12.6	3.5	180	53	2900	11.66	15	1.4	50	1631	289	758
	18	5	150	62		11.87		1.8				
	21.6	6	125	62		11.87		1.8				

注:1: GDLS、GDL-B、GDLS-B 型除重量 H 尺寸稍有不同外其性能参数与 GDL 型相同。

2:h1 尺寸仅用于 GDLS 及 GDLS-B

型号	流量		扬程 (m)	效率 (%)	转速 (r/min)	功率(KW)		汽蚀 余量 (m)	进出口 口径 (mm)	高度 H (mm)	重量 (kg)	高度 h1 (mm)
	(m ³ /h)	(L/s)				轴功 率	电机 功率					
65GDL24-12×2	16.8	4.67	27	56	2900	2.21	3	2.9	65	821	131	160
	24	6.67	24	65		2.41		3				
	28.8	8	22	67		2.57		3.1				
65GDL24-12×3	16.8	4.67	40.5	56	2900	3.31	4	2.9	65	936	153	235
	24	6.67	36	65		3.62		3				
	28.8	8	33	67		3.87		3.1				
65GDL24-12×4	16.8	4.67	54	56	2900	4.41	5.5	2.9	65	1061	182	310
	24	6.67	48	65		4.83		3				
	28.8	8	44	67		5.15		3.1				
65GDL24-12×5	16.8	4.67	67.5	56	2900	5.52	7.5	2.9	65	1136	198	385
	24	6.67	60	65		6.03		3				
	28.8	8	55	67		6.44		3.1				
65GDL24-12×6	16.8	4.67	81	56	2900	6.62	7.5	2.9	65	1211	214	460
	24	6.67	72	65		7.24		3				
	28.8	8	66	67		7.73		3.1				
65GDL24-12×7	16.8	4.67	94.5	56	2900	7.72	11	2.9	65	1416	263	535
	24	6.67	84	65		8.45		3				
	28.8	18	77	67		9.01		3.1				
65GDL24-12×8	16.8	4.67	108	56	2900	8.83	11	2.9	65	1491	273	610
	24	6.67	96	65		9.65		3				
	28.8	8	88	67		10.3		3.1				
65GDL24-12×9	16.8	4.67	121.5	56	2900	9.93	15	2.9	65	1556	293	685
	24	6.67	108	65		10.85		3				
	28.8	8	99	67		11.59		3.1				
65GDL24-12×10	16.8	4.67	135	56	2900	11.0	15	2.9	65	1641	303	760
	24	6.67	120	65		12.06		3				
	28.8	8	110	67		12.88		3.1				
80GDL36-12×2	25.2	7	27	59	2900	3.14	4	3.5	80	917	193	182
	36	10	24	68		3.46		4				
	43.2	12	21	67		3.68		4.2				
80GDL36-12×3	25.2	7	40.5	59	2900	4.71	5.5	3.5	80	1052	227	267
	36	10	36	68		5.19		4				
	43.2	12	31.5	67		5.53		4.2				
80GDL36-12×4	25.2	7	54	59	2900	6.29	7.5	3.5	80	1137	244	352
	36	10	48	68		6.92		4				
	43.2	12	42	67		7.37		4.2				
80GDL36-12×5	25.2	7	67.5	59	2900	7.86	11	3.5	80	1352	292	437
	36	10	60	68		8.67		4				
	43.2	12	52.5	67		9.22		4.2				
	25.2	7	81	59		9.43		3.5				

80GDL36-12×6	36	10	72	68	2900	10.39	11	4	80	1437	302	522
	43.2	12	63	67		11.06		4.2				
80GDL36-12×7	25.2	7	94.5	59	2900	11.0	15	3.5	80	1522	322	607
	36	10	84	68		12.12		4				
	43.2	12	73.5	67		12.9		4.2				
80GDL36-12×8	25.2	7	108	59	2900	12.58	15	3.5	80	1607	332	692
	36	10	96	68		13.85		4				
	43.2	12	84	67		14.75		4.2				
80GDL36-12×9	25.2	7	121.5	59	2900	14.14	18.5	3.5	80	1737	365	777
	36	10	108	68		15.59		4				
	43.2	12	94.5	67		16.5		4.2				
80GDL36-12×10	25.2	7	135	59	2900	15.71	18.5	3.5	80	1822	375	862
	36	10	120	68		17.31		4				
	43.2	12	115	67		18.4		4.2				
80GDL54-14×2	37.8	10.5	32	62	2900	5.32	7.5	3.7	80	967	218	182
	54	15	28	70		5.88		4				
	64.8	18	25	73.5		6.01		4.2				
80GDL54-14×3	37.8	10.5	48	62	2900	7.97	11	3.7	80	1182	267	267
	54	15	42	70		8.82		4				
	64.8	18	37.5	73.5		9.01		4.2				
80GDL54-14×4	37.8	10.5	64	62	2900	10.13	15	3.7	80	1267	287	352
	54	15	56	70		11.76		4				
	64.8	18	50	73.5		12.01		4.2				
80GDL54-14×5	37.8	10.5	80	62	2900	13.3	18.5	3.7	80	1397	320	437
	54	15	70	70		14.7		4				
	64.8	18	62.5	73.5		15.0		4.2				
80GDL54-14×6	37.8	10.5	96	62	2900	15.9	18.5	3.7	80	1482	330	522
	54	15	84	70		17.64		4				
	64.8	18	75	73.5		18.0		4.2				
80GDL54-14×7	37.8	10.5	112	62	2900	18.6	22	3.7	80	1592	373	607
	54	15	98	70		20.58		4				
	64.8	18	87.5	73.5		21.0		4.2				
80GDL54-14×8	37.8	10.5	128	62	2900	21.3	30	3.7	80	1607	400	692
	54	15	112	70		23.54		4				
	64.8	18	100	73.5		24.0		4.2				
80GDL54-14×9	37.8	10.5	144	62	2900	23.9	30	3.7	80	1757	421	777
	54	15	126	70		26.49		4				
	64.8	18	112.5	73.5		27.0		4.2				
8QGDL54-14×10	37.8	10.5	160	62	2900	26.6	37	3.7	80	1882	432	862
	54	15	140	70		29.43		4				
	64.8	18	125	73.5		30.0		4.2				

注:1: GDLS、GDL-B、GDLS-B 型除重量 H 尺寸稍有不同外其性能参数与 GDL 型相同。

2:h1 尺寸仅用于 GDLS 及 GDLS-B

型号	流量		扬程 (m)	效率 (%)	转速 (r/min)	功率(KW)		汽蚀 余量 (m)	进出口 口径 (mm)	高度 H (mm)	重量 (kg)	高度 h1 (mm)
	(m ³ /h)	(L/S)				轴功 率	电机 功率					
100GDL72-14×2	50.4	14	32	64	2900	6.87	11	4.2	100	1200	276	187
	72	20	28	73		7.53		4.5				
	86.4	24	24	73		7.74		4.7				
100GDL72-14×3	50.4	14	48	64	2900	10.3	15	4.2	100	1335	298	272
	72	20	42	73		11.29		4.5				
	86.4	24	36	73		11.61		4.7				
100GDL72-14×4	50.4	14	64	64	2900	13.7	18.5	4.2	100	1460	336	357
	72	20	56	73		15.05		4.5				
	86.4	24	48	73		15.48		4.7				
100GDL72-14×5	50.4	14	80	64	2900	17.17	22	4.2	100	1650	381	442
	72	20	70	73		18.81		4.5				
	86.4	24	60	73		19.35		4.7				
100GDL72-14×6	50.4	14	96	64	2900	20.6	30	4.2	100	1740	453	527
	72	20	84	73		22.57		4.5				
	86.4	24	72	73		23.22		4.7				
100GDL72-14×7	50.4	14	112	64	2900	24.03	30	4.2	100	1825	466	612
	72	20	98	73		26.34		4.5				
	86.4	24	84	73		27.09		4.7				
100GDL72-14×8	50.4	14	128	64	2900	27.4	37	4.2	100	1900	493	697
	72	20	112	73		30.1		4.5				
	86.4	24	96	73		30.96		4.7				
100GDL72-14×9	50.4	14	144	64	2900	30.9	37	4.2	100	1980	582	782
	72	20	126	73		33.9		4.5				
	86.4	24	108	73		34.83		4.7				
100GDL72-14×10	50.4	14	160	64	2900	34.3	45	4.2	100	2070	595	867
	72	20	140	73		37.6		4.5				
	86.4	24	120	73		38.7		4.7				
125GDL100-20×2	70	19.4	46	65	2900	13.5	18.5	4.2	125	1185	292	204
	100	27.7	40	74		14.7		4.5				
	120	33.3	34	73		15.2		4.7				
125GDL100-20×3	70	19.4	69	65	2900	20.2	30	4.2	125	1315	430	289
	100	27.7	60	74		22.1		4.5				
	120	33.3	51	73		22.8		4.7				
125GDL100-20×4	70	19.4	92	65	2900	27.0	37	4.2	125	1410	463	394
	100	27.7	80	74		29.5		4.5				
	120	33.3	68	73		30.4		4.7				
125GDL100-20×5	70	19.4	115	65	2900	33.7	45	4.2	125	1585	555	489
	100	27.7	100	74		36.8		4.5				
	120	33.3	85	73		38.1		4.7				
125GDL100-20×6	70	19.4	138	65	2900	40.5	55	4.2	125	1865	640	584
	100	27.7	120	74		44.2		4.5				
	120	33.3	102	73		45.7		4.7				
125GDL100-20×7	70	19.4	161	65	2900	47.2	75	4.2	125	1960	840	679
	100	27.7	140	74		51.5		4.5				
	120	33.3	119	73		53.3		4.7				
125GDL100-20×8	70	19.4	181	65	2900	54.0	75	4.2	125	2055	855	774
	100	27.7	160	74		58.9		4.5				
	120	33.3	136	73		60.9		4.7				
125GDL100-20×9	70	19.4	207	65	2900	60.7	75	4.2	125	2225	870	869
	100	27.7	180	74		66.3		4.5				
	120	33.3	153	73		68.5		4.7				
125GDL100-20×10	70	19.4	230	65	2900	67.5	90	4.2	125	2370	955	964
	100	27.7	200	74		73.6		4.5				

	120	33.3	170	73		76.1		4.7				
150GDL160-20×2	112	31.1	46	69	2900	20.3	30	4.4	150	1325	422	205
	160	44.4	40	78		22.3		4.5				
	192	53.3	34	77		23.1		4.7				
150GDL160-20×3	112	31.1	69	69	2900	30.5	37	4.4	150	1420	452	300
	160	44.4	60	78		33.5		4.5				
	192	53.3	51	77		34.6		4.7				
150GDL160-20×4	112	31.1	92	69	2900	40.6	55	4.4	150	1705	613	395
	160	44.4	80	78		44.7		4.5				
	192	53.3	68	77		46.2		4.7				
150GDL160-20×5	112	31.1	115	69	2900	50.9	75	4.4	150	1875	820	490
	160	44.4	100	78		55.9		4.5				
	192	53.3	85	77		57.8		4.7				
150GDL160-20×6	112	31.1	138	69	2900	61.0	75	4.4	150	1970	836	585
	160	44.4	120	78		67.1		4.5				
	192	53.3	102	77		69.3		4.7				
150GDL160-20×7	112	31.1	161	69	2900	71.2	90	4.4	150	2115	922	680
	160	44.4	140	78		78.3		4.5				
	192	53.3	119	77		80.9		4.7				
1150GDL160-20×8	112	31.1	184	69	2900	81.4	110	4.4	150	2400	1198	775
	160	44.4	160	78		89.4		4.5				
	192	53.3	136	77		92.4		4.7				
150GDL160-20×9	112	31.1	207	69	2900	91.6	110	4.4	150	2495	1214	870
	160	44.4	180	78		100.6		4.5				
	192	53.3	153	77		104.0		4.7				
150GDL160-20×10	112	31.1	230	69	2900	101.7	132	4.4	150	2670	1340	965
	160	44.4	200	78		111.8		4.5				
	192	53.3	170	77		115.5		4.7				

☆外型图及尺寸

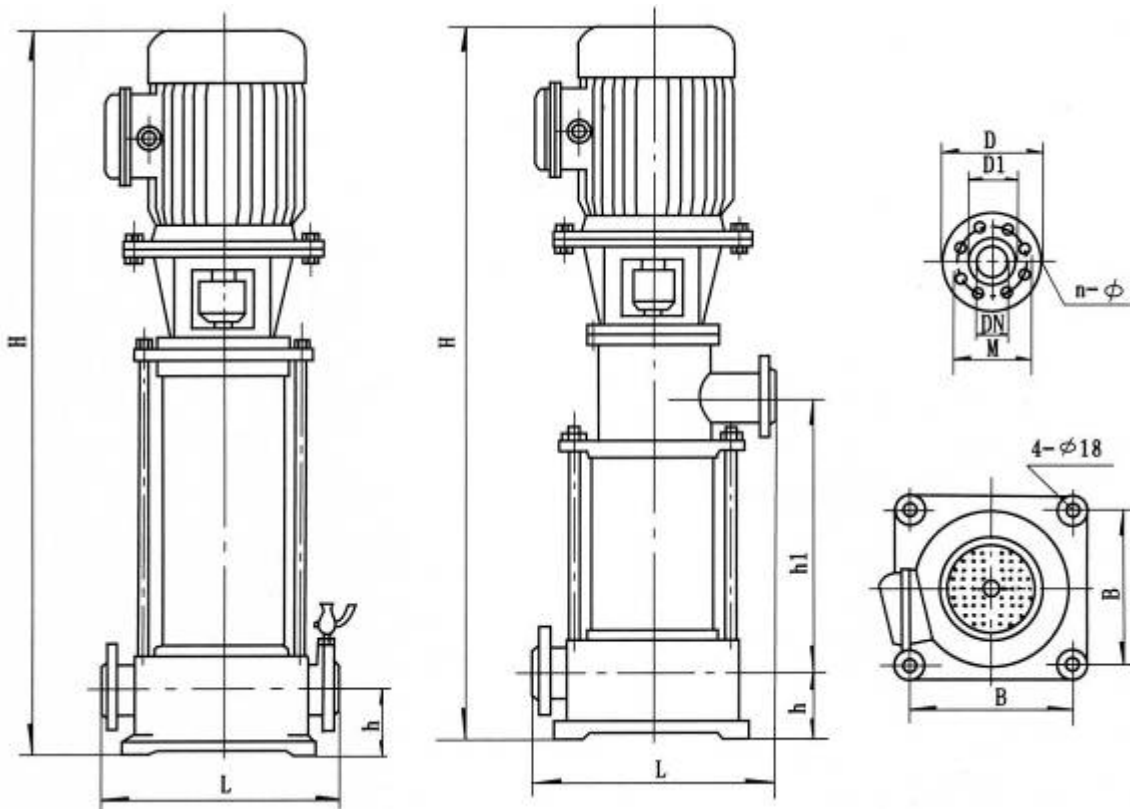

型号	h	L	B	进出口法兰				
				DN	M	n- ϕ	D1	D
25GDL(S)	75	300	205	ϕ 25	ϕ 85	4~ ϕ 14	ϕ 68	ϕ 115
40GDL(S)	90	330	215	ϕ 40	ϕ 110	4~ ϕ 18	ϕ 88	ϕ 150
50GDL(S)	100	360	235	ϕ 50	ϕ 125	4~ ϕ 18	ϕ 102	ϕ 160
65GDL(S)	110	360	235	ϕ 65	ϕ 145	4~ ϕ 18	ϕ 122	ϕ 180
80GDL(S)	130	420	300	ϕ 80	ϕ 160	8~ ϕ 18	ϕ 133	ϕ 200
100GDL(S)	140	420	300	ϕ 100	ϕ 180	8~ ϕ 18	ϕ 158	ϕ 220
125GDL(S)	160	500	350	ϕ 125	ϕ 210	8~ ϕ 18	ϕ 184	ϕ 250
150GDL(S)	180	500	350	ϕ 150	ϕ 240	8~ ϕ 22	ϕ 212	ϕ 285

☆ 安装说明

- 1.安装时管路重量不应承受在泵上，否则易损坏水泵；
- 2.泵与电机是整体结构，出厂时已由厂家校正，所以安装时无需调整，因此安装时十分方便；
- 3.安装时必须拧紧地脚螺栓，且每间隔一定时段应对泵进行检查防止其松动，以免水泵启动时发生剧烈振动而影响泵性能；
- 4.安装水泵前应仔细检查泵流道内有无影响水泵运行的硬物质(如石块、铁砂等)以免水泵运行时损坏过流部件；
- 5.为了维修方便和使用安全，在泵的进出口管路上安装一只调节阀及在泵进出口附近安装一只压力表，对于高扬程泵，为防止水锤，还应在出口闸阀前安装一只止回阀以应付突然断电等失去动力事故，从而确保水泵在最佳工况下运行，增长水泵的使用寿命；
- 6.泵用于有吸程场合，应装有底阀，并且进口管路不应有过多弯道，同时不得有漏水、漏气现象，以免影响水泵的吸入性能；
- 7.为不使杂质进入泵内而堵塞流道影响性能，应在泵进口前面安装过滤器；
- 8.安装管路前转动水泵的转子部件，应无磨擦声或卡死现象，否则应将泵拆开检查原因。

☆ 启动与停车

- 1.用手拔转联轴器，叶轮应无卡磨现象：转动灵活；
- 2.打开进口阀门，打开排气阀使液体充满整个泵腔，然后关闭排气嘴；
- 3.如输送热液体时，启动前应预热，升温速度为 $50^{\circ}\text{C} / \text{h}$ ，泵的预热是用所输送液体不断循环来达到，以使各部位受热均匀；
- 4.应先用手盘动泵几圈以使润滑水进入机械密封端面；
- 5.点动电机，确定转向是否正确。

启动与运行

- 1.全开进口阀门，关闭吐出管路阀门；
- 2.接通电源，当泵达到正常转速后，再逐渐打开吐出管路上的阀门，并调节到所需工况；
- 3.注意观察仪表读数，检查轴封泄漏情况，正常时机械密封泄漏为 3 滴 / 分，检查电机、轴承处温度 $\leq 75^{\circ}\text{C}$ ，如果发现异常情况，应及时处理。

停 车

- 1.逐渐关闭吐出管路阀门，切断电源；
- 2.关闭进口阀门；
- 3.如环境温度低于 0°C ，应将泵内液体放尽，以免冻裂水泵；
- 4.如长期停用，应将泵拆卸清洗，包装保管。

☆ 维护与保养

- 1.进水管路必须高度密封，不能漏水、漏气；
- 2.禁止泵在汽蚀状态下长期运行；
- 3.禁止泵在大流量工况运行时，电机超电流长期运行；
- 4.定时检查泵运行中的电机电流值，尽量使泵在设计工况范围内运行；
- 5.泵在运行中应有专人看管，以免发生意外；
- 6.泵每运行 500 小时应对轴承进行加油；
- 7.泵进行长期运行后，由于机械磨损，使机组噪声及振动增大时，应停车检查，必要时可更换易损零件及轴承，机组大修期一般为一年。

机械密封的维护与保养

- 1.机械密封润滑液应清洁无固体颗粒；
- 2.严禁机械密封在干磨情况下工作；
- 3.起动前应盘动泵(电机)几圈，以免突然起动造成机械密封断裂损坏。

☆ 故障分析及排除方法

故障现象	可能产生的原因	排除方法
1.水泵不出水	a.进出口阀门未打开，进出管路阻塞，叶轮流道阻塞 b.电机运行方向不对，电机缺相转速很慢 c.吸入管漏气 d.泵没灌满液体，泵腔内有空气 e.进口供水不足，吸程过高，底阀漏水 f.管路阻力过大，泵选型不当	a.检查，去除阻塞物 b.调整电机转向，紧固电机接线 c.拧紧各密封面，排除空气 d.打开泵上盖或打开排气阀，排尽空气 e.停机检查、调整(并网自来水管和带吸程使用易出现此现象) f.减少管路弯道，重新选泵
2.水泵流量不足	a.先按 1.原因检查 b.管道、泵流道或叶轮部分阻塞，水垢积、阀门开度不足 c.电压偏低 d.叶轮磨损	a.先按 1.排除 b.去除阻塞物，重新调整阀门开度 c.稳压 d.更换叶轮
4.功率过大	a.超过额定流量使用 b.吸程过高 c.泵轴承磨损	a.调节流量，关小出口阀门 b.降低 c.更换轴承
5.杂音振动	a.管路支撑不稳 b.液体混有气体 c.产生汽蚀 d.轴承损坏 e.电机超载运行	a.稳固管路 b.提高吸入压力，排气 c.降低真空度 d.更换轴承 e.调整按 5.
6.电机发热	a.流量过大，超载运行 b.局部摩擦 c.电机轴承损坏 d.电压不足	a.关小出口阀门 b.检查排除 c.更换轴承 d.稳压
7.水泵漏水	a.机械密封磨损 b.泵体有砂孔或破裂 c.密封面不平整 d.安装螺栓松懈	a.更换 b.焊补或更换 c.修整 d.紧固