

# IS IH 系列

# 单级离心泵

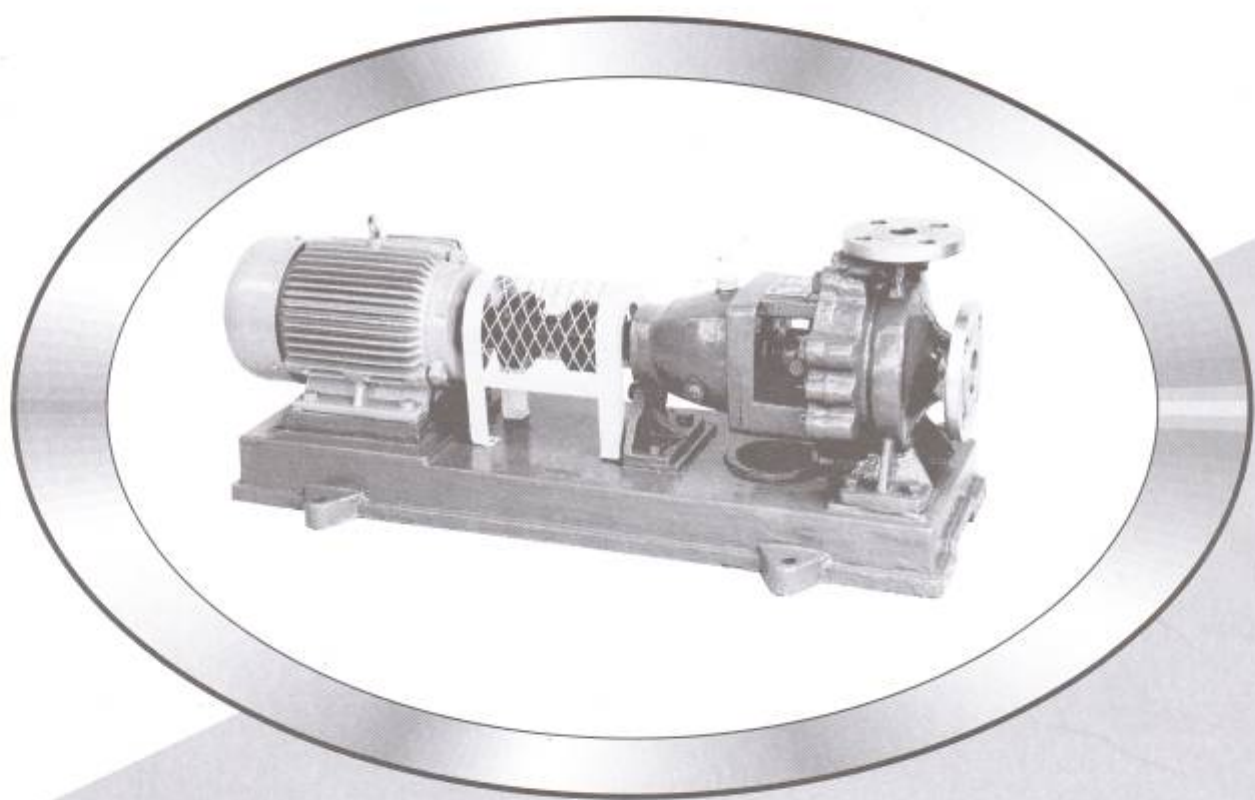

DAN JI LI XIN BENG

上海协晋泵业有限公司

SH 卧式不锈钢化工泵 Shanghai XieJin Pumps CO.,LTD.

☆ 产品概述

IH 型不锈钢化工泵是单级单吸悬臂式离心泵，其标记额定性能点和尺寸等效采用国际标准 ISO 2858-1975(E)，是一种用以取代 F 型耐腐蚀泵更新换代的节能产品，适用于化工、石油、冶金、电站、食品、制药、合成纤维等部门输送温度在-20℃~105℃(订制最高温度可达 400℃)的腐蚀性介质或物理、化学性能类似于水的介质。

IH 型化工泵的性能范围(按设计点)

流量：6.3~400 米<sup>3</sup>/时

扬程：5~125 米

泵的最高工作设计压力为 1.6 兆帕。

用户可根据被输送介质的腐蚀性程度对泵的过流部分主要零件选用不同材料。泵的过流部分主要零件的材料及其代号有下列五种：

材料名称	ZG1Cr18Ni9	ZG1Cr18Ni9Ti	ZG0Cr18Ni12Mo2Ti	ZG1Cr18Ni12Mo2Ti	ZG1Cr18Mn13Mo2CuN
代号	303	305	306	307	402

注：除上表已列出的材料外、生产厂还可根据用户需要，选用适合制造该系列化工泵的材料。

所选材料及其代号应原则符合 GB2100-80。对国家尚未规定代号的材料，允许采用国际或国内通用的材料代号(如行业或工厂标准)。

型号意义

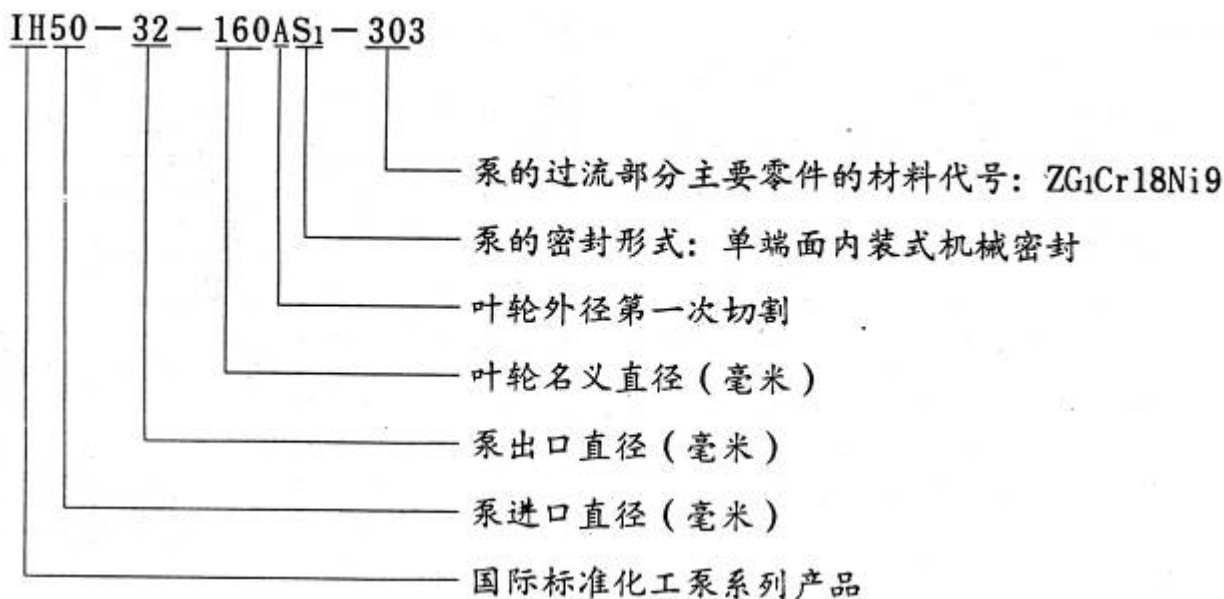

☆ 性能参数表

型号	转速 n(r/min)	流量Q		扬程H (m)	效率n (%)	功率P		必需汽蚀余量 (NPSH) r (m)
		(m <sup>3</sup> /h)	(L/s)			轴功率P <sub>轴</sub>	电机功率P <sub>电</sub>	
						(KW)		
IH50-32-125	2900	7.5	2.08	23	43	1.09	2.2	2.0
		12.5	3.47	20	51	1.33		2.0
		15.0	4.17	18	49	1.50		2.5
	1450	3.75	1.04	5.75	36	0.16	0.55	
		6.3	1.74	5.0	45	0.19		
		7.5	2.08	4.5	44	0.21		
IH50-32-160	2900	7.5	2.08	34.5	33	2.13	3	2.0
		12.5	3.47	32	46	2.37		2.0
		15.0	4.17	30	50	2.45		2.5
	1450	3.75	1.04	8.6	29	0.30	0.6	2.0
		6.3	1.74	8.0	40	0.34		2.0
		7.5	2.08	7.5	43	0.36		2.5
IH50-32-200	2900	7.5	2.08	51.8	28	3.78	5.5	2.0
		12.5	3.47	50	39	4.36		2.0
		15.0	4.17	48	43	4.56		2.5
	1450	3.75	1.04	12.9	23	0.57	0.75	
		6.3	1.74	12.5	33	0.65		
		7.5	2.08	12.0	36	0.68		
IH50-32-250	2900	7.5	2.08	82	23	7.28	11	2.0
		12.5	3.47	80	33	8.25		2.0
		15.0	4.17	78.5	36.5	8.79		2.5
	1450	3.75	1.04	20.5	17	1.23	1.5	
		6.3	1.74	20	27	1.27		
		7.5	2.08	19j6	31	1.29		
IH65-50-125	2900	15	4.17	21.3	47	1.85	3	
		25	6.94	20	62	2.2		
		30	8.33	18.6	63	2.4		
	1450	7.5	2.08	5.4	44	0.25	0.55	
		12.5	3.47	5	55	0.31		
		15	4.17	4.5	56	0.33		
IH65-50-160	2900	15	4.17	34.2	44	3.18	5.5	2.0
		25	6.94	32	57	3.82		2.0
		30	8.33	30	59	4.15		2.0
	1450	7.5	2.08	8.55	39	0.45	0.75	
		12.5	3.47	8	51	0.53		
		15.0	4.17	7.5	52.5	0.58		
IH65-40-200	2900	15	4.17	53.2	41	5.30	7.5	2.0
		25	6.94	50	52	6.55		2.0
		30	8.33	47.6	53.5	7.27		2.5
	1450	7.5	2.08	13.3	35	0.78	1.1	
		12.5	3.47	12.5	46	0.93		
		15.0	4.17	11.9	47.5	1.02		
IH65-40-250	2900	15	4.17	81.2	34	9.76	15	
		25	6.94	80	46	11.84		
		30	8.33	78.4	50	12.8		
	1450	7.5	2.08	20.3	28	1.48	2.2	
		12.5	3.47	20	39	1.75		
		15	4.17	19.6	43	1.86		
IH65-40-315	2900	15	4.17	126.8	28	18.5	30	2.0
		25	6.94	125	39	21.8		2.0
		30	8.33	124	42.5	23.8		2.5
	1450	7.5	2.08	32.4	22	3.0	4	
		12.5	3.47	32	33	3.3		
		15.0	4.17	31.7	37	3.5		

型号	转速 n(r/min)	流量Q		扬程H (m)	效率n (%)	功率P		必需汽蚀余量 (NPSH) <sub>r</sub> (m)
		(m <sup>3</sup> /h)	(L/s)			轴功率P <sub>轴</sub>	电机功率P <sub>电</sub>	
						(KW)		
IH80-65-125	2900	30	8.33	23.2	60	3.16	5.5	3.0
		50	13.9	20	69	3.95		3.0
		60	16.7	17.6	67	4.29		4.0
	1450	15	4.17	5.8	54	0.44	0.75	2.5
		25	6.94	5.0	64	0.53		2.5
		30	8.33	4.4	62	0.58		3.0
IH80-65-160	2900	30	8.33	36	57	5.16	7.5	2.0
		50	13.9	32	67	6.5		2.3
		60	16.7	28.4	65	7.14		3.3
	1450	15	4.17	9	50	0.74	1.5	
		25	6.94	8	62	0.88		
		30	8.33	7.2	62	0.95		
IH80-50-200	2900	30	8.33	55.2	53	8.5	15	2.0
		50	13.9	50	63	10.8		2.5
		60	16.7	45.2	62	11.9		3.2
	1450	15	4.17	13.5	44	1.25	2.2	2.0
		25	6.94	12.5	57	1.49		2.0
		30	8.33	11.5	58	1.6		2.5
IH80-50-250	2900	50	13.88	80	58	18.8	22	
	1450	25	6.94	20	52	2.62	3	
IH80-50-315	2900	50	13.88	125	52	32.7	37	
	1450	25	6.94	32	46	4.73	5.5	
IH100-50-125	2900	100	27.7	20	72	18.9	11	2.5
	1450	50	13.88	12.5	68	2.5	1.5	2.0
IH100-80-160	2900	60	16.7	37	60	10.1	15	3.8
		100	27.8	32	73	11.9		4.3
		120	33.3	28	73	12.5		5G
	1450	30	8.33	9.25	58	1.3	2.2	3.0
		50	13.9	8	69	1.58		3.4
		60	16.7	7	68	1.68		3.7
IH100-65-200	2900	60	16.7	56	63	14.5	22	3.4
		100	27.8	50	72	18.9		3.9
		120	33.3	44	71	20.3		5.2
	1450	30	8.33	14.0	60	1.91	4	2.5
		50	13.9	12.5	68	2.5		2.5
		60	16.7	11.0	63	2.85		3.0
IH100-65-250	2900	60	16.7	88	57	25.2	37	3.0
		100	27.8	80+	68	32.0		3.6
		120	33.3	74	67	36.1		4.5
	1450	30	8.33	22	50	3.6	5.5	2.5
		50	13.9	20	63	4.3		2.5
		60	16.7	18.5	64	4.7		3.0
IH100-65-315	2900	60	16.7	132	48	44.9	75	2.8
		100	27.8	125	62	54.9		3.2
		120	33.3	119	64	60.8		4.2
	1450	30	8.33	33.5	44	6.2	11	2.0
		50	13.9	32	58	7.5		2.0
		60	16.7	30.5	60	8.3		2.5
IH125-100-200	2900	120	33.3	61	68	29.3	45	4.5
		200	55.6	50	77	35.4		5.0
		240	66.7	41	70	38.3		5.8
	1450	60	16.7	15.25	64	3.89	7.5	2.5
		100	27.8	12.5	73	4.66		2.9
		120	33.3	10.25	66	5.08		3.6

型号	转速n(r/min)	流量Q		扬程H (m)	效率n (%)	功率P		必需汽蚀余量 (NPSH) <sub>r</sub> (m)
		(m <sup>3</sup> /h)	(L/s)			轴功率P <sub>轴</sub>	电机功率P <sub>电</sub>	
						(KW)		
IH125-100-250	2900	120	33.3	90	62	47.4	75	3.7
		200	55.6	80	75	58.1		4.5
		240	66.7	73	74	64.5		5.5
	1450	60	16.7	22.5	59	6.23	11	2.0
		100	27.8	20	72	7.56		2.3
		120	33.3	18.25	71	8.40		3.0
IH125-100-315	2900	200	55.55	80	75	58.1	90	
	1450	100	27.77	32	67	13	22	
IH125-100-400	1450	100	27.77	50	62	22	30	
IH150-125-250	1450	120	33.3	24.8	66	12.3	30	2.5
		200	55.6	20	77	14.1		2.8
		240	66.7	15	68	14.4		3.5
IH150-125-315	1450	120	33.3	36.3	63	18.8	30	2.5
		200	55.6	32.0	75	23.2		2.8
		240	66.7	28.5	72	25.9		3.8
IH150-125-400	1450	120	33.3	57.5	61	30.8	55	2.0
		200	55.6	50	70	38.9		2.5
		240	66.7	44	63	45.6		3.0
IH200-150-250	1450	400	111.1	20	79	27.6	37	
IH200-150-315	1450	240	66.7	35.6	67	34.7	55	3.0
		400	111.1	32.0	79	44.1		3.5
		460	127.8	29.4	77	47.8		4.0
IH200-150-400	1450	240	66.7	55.8	67	54.4	90	3.0
		400	111.1	50	78	69.8		3.5
		460	127.8	47	75	78.5		4.0

☆ 产品结构

二、结构简介

IH 化工泵的结构特点(见图)是,泵盖通过止口固定在中间支架上,然后通过泵体与中间支架止口的连接把泵盖夹紧在中间。泵体是轴向吸入,径向排出,脚支承式,可直接固定在底座上。悬架部件通过止口固定在中间支架上,并用悬架支架支撑在底座上。为拆卸方便,设计了加长联轴器,检修时可以不拆卸进出口联接管路、泵体和电动机。只需拆下加长联轴器的中间联接件,即可退出转子部件进行检修。这是国际上一种通用的结构形式。

泵的密封型式采用填料密封或机械密封,由用户根据需要选用,同时根据需要允许采用适合于 IS03069 规定的密封空腔尺寸的其他结构的轴封型式(如带波纹管的机械密封和付叶轮密封等等)。

泵的尺寸见图 3 和表 2,泵盼吸入口和排出口的法兰连接尺寸见图 4 和表 3。

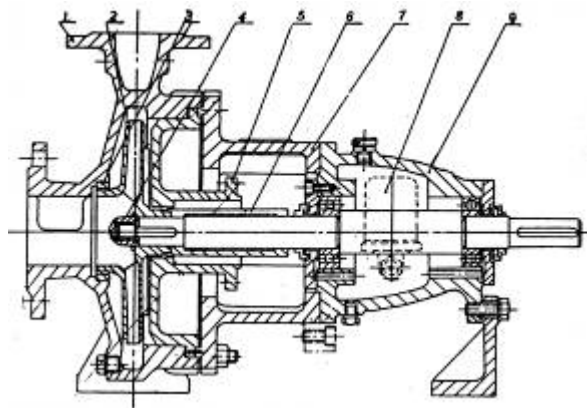

- 1、泵体
- 2、叶轮
- 3、密封环
- 4、叶轮螺母
- 5、泵盖
- 6、密封部件
- 7、中间支架
- 8、轴
- 9、悬架部件

## ☆ 装配与拆卸

### 1、拆卸：

由于采用了加长联轴器，拆卸泵时，不必拆卸进、出口管路，泵体和电机。只需拆下加长联轴器中的中间联轴器，即可拆出转子部件，进行维修、保养。

1、拆下泵体上的泄液管堵和悬架体上的放油管堵，放净泵内液体和悬架体内的润滑油。（注：如泵上还有另外附加管路亦应拆下）。

2、拆开泵体与中间支架的联结、并将中间支架、悬架部件和泵盖等全部转子部件从泵体中一起退出。

3、拆下叶轮螺母、取下叶轮和键。

4、将泵盖连同轴套、机械密封端盖和机械密封等部件一起从轴上退出。注意勿使轴套相对于泵盖等发生滑动，然后再拆下机械密封端盖，将机械密封连同轴套一起取下，再将轴套和机械密封拆开。

如果密封采用填料，则可从泵盖中直接拆下轴套，再顺次拆下填料压盖，填料和填料环等。

如果密封采用特殊结构，应注意不同的拆卸方法。

5、拆下中间支架与悬架支架。

6、拆下泵联轴器和键。

7、拆下悬架体两端的防尘盘和轴承的前、后盖，再将轴连同轴承一起从悬架体内取下。

8、从泵轴上拆下轴承。

### 2、装配

与拆卸程序相反进行。

## ☆ 安装说明

1、泵的安装是否合理，对泵的正常运行和使用寿命有很重要的影响，所以安装前必须仔细校正，不得草率，泵的外形及安装尺寸，详见图 5 和表 4。

2、必须保证泵在工作时不超过其允许汽蚀余量。泵的吸上高度(或倒灌高度)必须根据泵的汽蚀余量特性，管路阻力损失特性及高温水的吸入液面压力来确定。

泵吸上使用情况下，应在吸入管路上装上底阀，并在出口管路上设置灌液螺孔或阀门，以供起动前灌泵之用；

泵倒灌使用情况下，应在吸入管路上装上阀门和过滤器，以免杂物进入。

3、吸入和吐出管路应该有支架，不能用泵作支承。

4、安装泵的地点，应便于巡回检查和检修。

### 5、安装顺序

(1)将机组放在埋有地脚螺栓的基础上，在底座和基础之间放置成对的楔垫作找正之用。

(2)松开联轴器。用水平仪分别放在泵轴或底座上，通过调整楔垫，找正机组的水平后，适当拧紧地脚螺栓，以防走动。

(3)用混凝土灌注底座和地脚螺栓孔。

(4)待混凝土干固后，应拧紧地脚螺栓，并重新检查泵轴的水平度。

(5)在接好管路及确定原动机转动方向以后，接上联轴器，再核对一遍轴的同心度，测量联轴器的外园上下，左右的差异不得超过 0.1mm，两联轴器端面间隙，在\_周内最大和最小的间隙差不得超过 0.3mm。

(6)在机组实际运行 3-4 小时后作最后检查，如无不良现象，则认为安装合格。

## ☆ 使用说明

### 1、起动前准备

(1) 起动前要把泵和现场清理干净。

(2) 检查托架内润滑油量是否适量(油面在油位计中心线 2mm 左右)油位计是否完好。

(3) 未接联轴器前检查原动机的转向, 与泵的转向箭头一致后, 接好联轴器。

(4) 在装好机械密封或填料和联轴器后可方便地用手转动泵轴, 应无碰擦现象, 并将联轴器的防护罩安装好。

(5) 泵在吸上情况下使用, 起动前应灌泵或抽真空; 泵在倒灌情况下使用, 起动前应用所输送液体将泵灌满, 驱除泵中的空气后, 将吐出管的闸阀关闭。

(6) 起动前检查基础螺栓有无松动。压盖是否歪斜, 以及润滑油和冷却水的供应情况。

### 2、起动

(1) 关闭进出口压力(或真空)计和出水阀门、(如有旁通管、此时也应关闭。)起动电机(最好先点动、确认泵转向正确后, 才开始正式运行。), 然后打开进出口压力(或真空)计, 当泵达到正常转速, 且仪表指出相应压力时, 再慢慢打开出水阀门, 调节到需要的工况。在吐出管路关闭的情况下, 泵连续工作的时间, 不能超过 3 分钟。

(2) 起动过程中要时时注意原动机的功率读数及泵的振动情况, 振动数不应超过 0.06 毫米, 测定部位是轴承座。

(3) 密封情况: 机械密封应无泄漏、发热现象、填料密封应呈连续滴流状态。

### 3、运行

(1) 经常检查泵和电机的发热情况(轴承的温升不应超过 75℃)及油位计供油情况。(一般每运行 1500 小时后, 要全部更换润滑油一次)。

(2) 不能用吸入阀来调节流量, 避免产生汽蚀。

(3) 泵不宜在低于 30% 设计流量下连续运转, 如果必须在该条件下连续运转, 则应在出口处安装旁通管, 排放多余的流量。

(4) 注意泵运转有无杂音, 如发现异常状态时, 应及时消除或停车检查。

### 4、停止

(1) 缓慢关闭吐出管路闸阀(如果泵在倒灌情况下使用, 还要关闭吸入管路的闸阀)、并关闭各种仪表的开关。

(2) 切断电源

(3) 如果密封采用外部引液时, 还要关闭外引液阀门。

(4) 如果环境温度低于液体凝固点时, 要放净泵内的液体, 以防冻裂。

(5) 如果长时间停车不用, 除将泵内的腐蚀性液体放净外, 各零部件应拆卸清洗干净, 尤其是密封腔。最好是将泵拆下清洗后重新装好, 除涂油防锈处理和封闭泵进、出口外, 还应定期检查。

## ☆ 机械密封注意事项

1、由于机械密封一般适用在清洁的, 无悬浮颗粒的介质中使用, 因此, 对新安装的管路系统和储液灌, 应认真冲洗干净, 严防固体杂质进入机械密封端面而使密封失效。

2、在易结晶的介质中, 使用机械密封应注意经常冲洗。停车后重新起动前, 要将机械密封上的结晶清洗干净。

3、拆卸机械密封应仔细, 不许用手锤, 铁器等敲击, 以免破坏动、静环密封面。

4、如果有污垢拆不下来时, 应设法清除污垢, 冲洗干净后再进行拆卸, 以免损坏密封元件。

5、安装机械密封前, 应检查所有密封元件是否有失效或损坏, 如有则应重新修复或更换。

6、应严格检查动环与静环的相对磨擦密封面, 不允许有任何细微的划痕、碰伤等缺陷。所有另部件, 包括泵体, 叶轮, 密封腔等在装配前均应冲洗干净, 尤其是动、静环端面, 要用清洁, 柔软的布或棉纱认真擦拭干净, 然后涂上一层清洁的油脂或机油。

- 7、装配中要注意消除偏差，紧固螺钉时，要均匀拧紧，避免发生偏斜，使密封失效。
- 8、正确调整弹簧的压缩量，泵安装好以后，以手扳动转子时，应感觉到密封弹簧既有一定的压缩量，而又能轻快、灵活地转动没有咬紧的感觉。如感觉太紧或盘不动，则应适当调松一些。
- 9、对有外部冲洗的机械密封，起动前应先开启冲洗液，使密封腔内充满密封液。停车时，先停泵，后关密封冲洗液。

☆ 常见故障及排除方法

故障现象							
产生振动及噪音				密封处泄漏过多			
功率消耗过大				轴封(包括填料函)发热			
流量、扬程不足				泵过份发热及转不动			
泵输不出液体				轴承发热及轴承磨损			
故障的可能因素				消除方法			
泵内或吸入管内留有空气	●	●	●				重新灌泵排除空气
吸上扬程过高或灌注高不够	●	●	●				降低泵位，增加进口处压力
吸入管经过小或有杂物堵塞	●	●	●				加大吸入管径，清除堵塞
吸入管浸入深度不够或漏气	●	●					增大浸入深度或检修管路
转速过高或过低	●	●	●				按规定要求检查原动机转速
泵转向不对	●	●					调整转向
总扬程与泵扬程不符	●	●	●				降低吐出系统阻力或高度
介质重度与粘度与泵要求不符	●	●	●				应进行换算
在流量过小时运转产生振动			●	●		●	●加大流量或设旁通循环管
泵与电机轴线不一致或轴弯曲			●	●		●	●校正
转动部分与固定部分有磨擦			●	●		●	●检修泵或改善使用工况
轴承磨损严重或损坏			●		●	●	●更换之
密封环磨损过多		●	●				更换之
轴套、填料或动静环磨损过多			●	●	●	●	更换之
填料(或机械密封)选用或安装不当			●	●	●	●	按使用要求重新选用或安装
转动部分不平衡引起振动			●	●	●	●	●检查原因设法消除
油室油量过多(或油过脏)			●	●			●按油位要求计加油(或换新油)
管路或泵内有杂物堵塞	●	●	●				检查并排除
密封液压力不当					●	●	应按密封腔前的压力，加大0.049~0.147MPa
填料压盖过紧或过松			●	●	●		适当调整之



☆ 泵尺寸

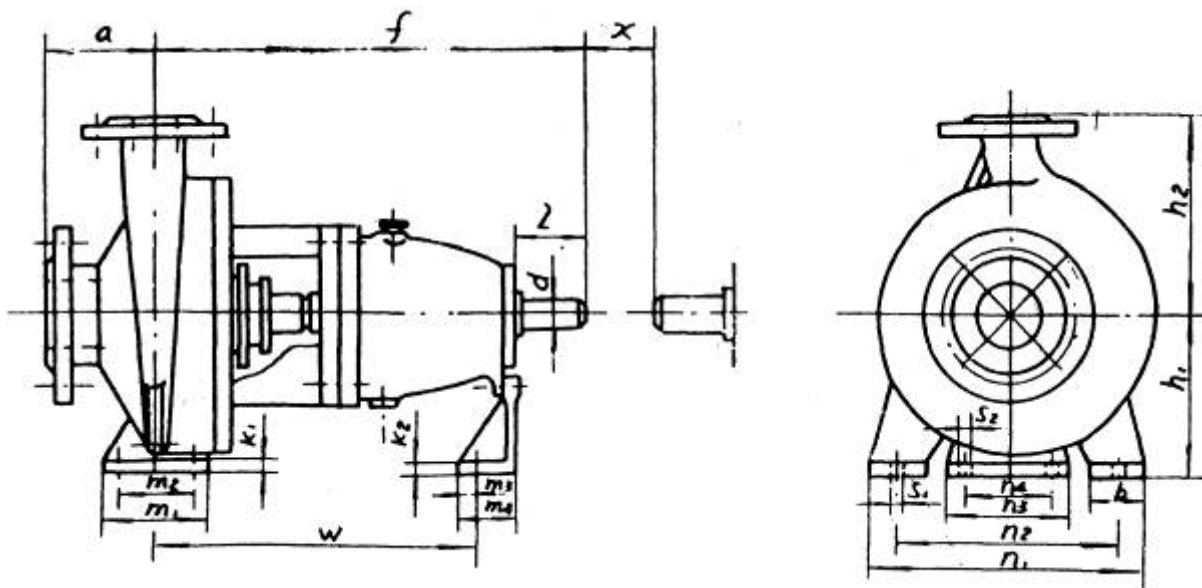

产品型号	泵				泵脚座												W	螺栓孔		轴端		间隔	
	a	f	h1	h2	b	m1	m2	m3	m4	n1	n2	n3	n4	K1	K2	S1		S2	d	L	X		
IH50-32-125	80	385	112	140	50	100	70	19	60	190	140	110	145	12	10	285	M12	M12	24	50	100		
IH50-32-160			132	160						240	190												
IH50-32-200			160	180																			
IH50-32-250	100	500	180	225	65	125	95	25	65	320	250			16	14	370			32	80			
IH65-50-125	80	385	112	140	50	100	70	19	60	210	160	110	145	12	10	285	M12	M12	24	50	100		
IH65-50-160			132	160						240	190												
IH65-40-200			100	160						180	265								212				
IH65-40-250		500	180	225	65	125	95	25	65	320	250			16	14	370			32	80			
IH65-40-315	125		200	250						345	280												
IH80-65-125	100	385	132	160	50	100	70	19	60	240	190	110	145	12	10	285	M12	M12	24	50	100		
IH80-65-160			160	180						265	212												
IH80-50-200				200																			
IH80-50-250	125	500	180	225	65	125	95	25	65	320	250			16	14	370			32	80			
IH80-50-315			225	280						345	280												
IH100-80-125	100	385		180	65	125	95	19	60	280	212	110	145	12	10	285	M12	M12	24	50	100		
IH100-80-160		500	160	200						24									16	370		32	80
IH100-65-200			180	225						25	65								320	250		14	
IH100-65-250	125		200	250	80	160	120			360	280						M16						
IH100-65-315		530	225	280				28		400	315								42	110			
IH125-100-200	125	500	200	280	80	160	120	25	65	360	280	110	145	16	14	370	M16	M12	32	80	140		
IH125-100-250	140	530	225					28		400	315			20					42	110			
IH125-100-315			250	315																			
IH125-100-400			280	355	100	200	150			500	400						M20						
IH150-125-250			250		80	160	120	28	65	400	315	110	145	20	14	370	M16	M12	42	110	140		
IH150-125-315	140	530	280	355	100	200	150			500	400						M20						
IH150-125-400			315	400																			
IH200-150-250	160	530	280	375	100	200	150	28	65	500	400	110	145	20	14	370	M20	M12	42	110	180		
IH200-150-315		670	315	400				38	80	550	450	140	200	30	500					M16	48		
IH200-150-400				450																			

IH 卧式不锈钢化工泵

☆ 法兰尺寸

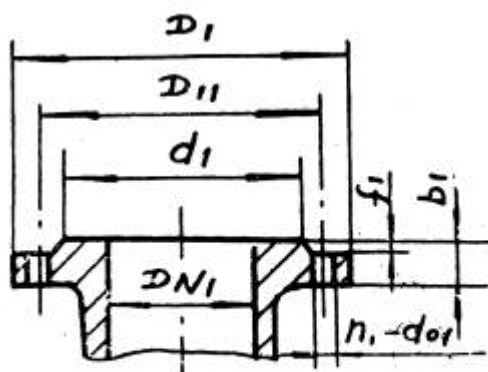

吸入口法兰

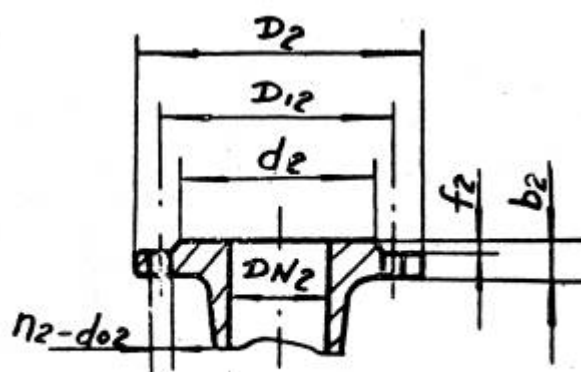

排出口法兰

产品型号	吸入口法兰尺寸							排出口法兰尺寸						
	DN1	D1	D11	d1	b1	f1	n1-d01	DN2	D2	D12	d2	b2	f2	n2-d02
IH50-32-125	50	165	125	99	20	3	4-17.5	32	140	100	76	18	2	4-17.5
IH50-32-160														
IH50-32-200														
IH50-32-250														
IH65-50-125	65	185	145	118	20	3	4-17.5	50	150	110	84	18	3	4-17.5
IH65-50-160														
IH65-40-200														
IH65-40-250														
IH65-40-315	80	200	160	132	20	3	8-17.5	65	165	125	99	20	3	4-17.5
IH80-65-125														
IH180-65-160														
IH80-50-200														
IH80-50-250	100	220	180	156	22	3	8-17.5	50	185	145	118	20	3	4-17.5
IH80-50-315														
IH100-80-125														
IH100-80-160														
IH100-65-200	125	250	210	184	22	3	8-17.5	80	200	160	132	20	3	4-17.5
IH100-65-250														
IH100-65-315														
IH125-100-200														
IH125-100-250	150	285	240	211	24	3	8-22	65	250	210	184	22	3	8-17.5
IH125-100-315														
IH125-100-400														
IH150-125-250														
IH150-125-315	200	340	295	266	24	3	12-22	80	285	240	211	24	3	8-22
IH150-125-400														
IH200-150-250														
IH200-150-315														
IH200-150-400	200	340	295	266	24	3	12-22	100	285	240	211	24	3	8-22
IH200-150-250														
IH200-150-315														
IH200-150-400														

☆ 外形尺寸

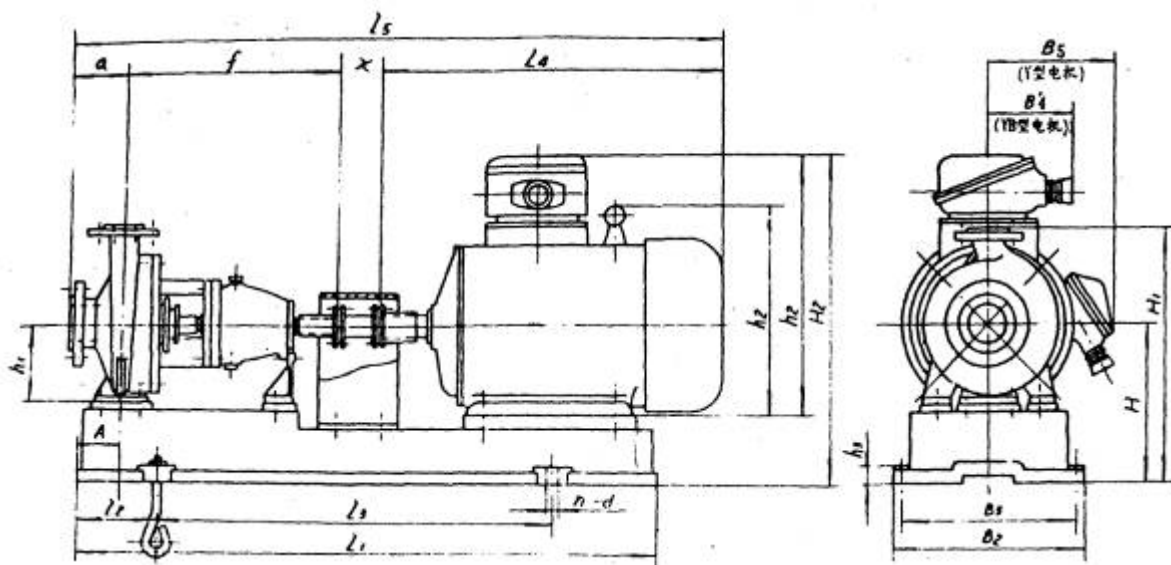

产品型号	电机型号 功率 (Kw)	外形及安装尺寸																				
		A	L1	L2	L3	L4	a	f	X	L5	B2	B3	B4/B5	h1	h2/h2'	h3	H	H1	H2	n-d		
IH50-32-125	YB801-4/0.55	80	820	150	540	330	80	385	100	895	360	320	150/225	112	170/325	25	197	317	442	4-φ19		
	YB802-2/1.1					360				925			155/225		190/340				197		317	447
	YB90S-2/1.5					385				950			155/225		190/340				30		447	
	YB90L-2/2.2					430				995			180/225		245/370				30		467	
	YB100L-2/3.0																					
IH50-32-160	YB801-4/0.55	80	820	150	540	330	80	385	100	895	360	320	150/225	132	170/325	25	217	377	462	4-φ19		
	YB802-4/0.75					360				925			155/225		190/340	25			467			
	YB90S-4/1.1					385				950			180/225		245/370	30			482			
	YB90L-2/2.2					430				995			190/225		265/385	30			490			
	YB100L-2/3.0					460				1025			190/225		265/385	30			490			
	YB112M-2/4.0																					
	YB132S1-215.5					510				1070			210/240		315/430	60			510		4-φ24	
IH50-32-200	YB801-4/0.55	80	820	150	540	330	80	385	100	895	360	320	150/225	160	170/325	30	245	425	490	4-φ19		
	YB802-4/0.75					360				925			155/225		190/340	25			425		495	
	YB90S-4/I. I					380				950			155/225		190/340	30			495			
	YB90L-4/1.5					460				1025			190/225		265/385	30			518			
	YB112M-2/4.0																					
	YB132S1-215.5					510				1075			210/240		315/430	30			543		4-φ24	
	YB132S2-2/7.5																					
	YB160M1-2/11					655				1220			255/240		385/485	30			585			
IH50-32-250	YB90S-4/1.1	95	1020	190	660	360	100	500	100	1060	450	400	155/255	180	190/340	30	265	490	515	4-φ24		
	YB90L-4/1.5					385				1085			155/255		190/340				265		490	515
	YB100L1-4/2.2					430				1130			180/225		245/370				30		535	
	YB100L2-4/3.0																					
	YB132S2-2/7.5					510				1210			210/240		315/430				30		578	4-φ24
	YB160M1-2/11					655				1355			255/240		385/485				300		525	625
	YB160M2-2/15																					
	YB160L-2/18.5					695				1395			285/240		385/485				300		625	
	YB180M1-2/22					730				1430			285/240		430/525						645	

产品型号	电机型号 功率(Kw)	外形及安装尺寸																				
		A	L1	L2	L3	L4	a	f	X	L5	B2	B3	B4/B5	h1	h2/h2'	h3	H	H1	H2	n-d		
IH65-50-125	YB801-4/0.55	80	820	150	540	330	80	385	100	895	360	320	150/225	112	170/325	25	197	337	442	4-φ19		
	YB802-4/0.75					950				155/225			190/340		447							
	YB90L-2/2.2		920	170	600	385				995	390	350	180/225		245/370				30		467	
	YB100L-2/3.0					430							190/225		265/385						495	
	YB112M-2/4.0		1020	190	660	460				1075	450	400	210/240		315/430				30		490	4-φ24
	YB132S1-2/5.5					510							1075		450						400	210/240
IH65-50-160	YB801-4/0.55	80	820	150	540	330	80	385	100	895	360	320	150/225	132	170/325	25	217	377	462	4-φ19		
	YB802-4/0.75					950				155/225			190/340		467							
	YB90S-4/1.1		920	170	600	360				995	390	350	180/225		245/370				30		487	
	YB90L-4/1.5					385							190/225		265/385						490	
	YB100L-2/3.0		1020	190	660	430				1075	450	400	210/240		315/430				30		515	4-φ24
	YB112M-2/4.0					460							1075		450						400	
	YB132S1-2/5.5		1140	210	740	655				1220	490	440	255/240		385/485				30	557	4-φ24	
	YB132S-2/7.5					510							1075		450					400		210/240
YB160M1-2/11	655	1220	490	440	255/240	385/485	557	4-φ24														
IH65-40-200	YB802-4/0.75	80	920	170	600	330	100	385	100	915	390	350	150/225	160	170/325	30	245	425	490	4-φ19		
	YB90S-4/1.1					945				155/225			190/340		495							
	YB90L-4/1.5		920	170	600	360				970	350	180/225	245/370		30				515			
	YB100L1-4/2.2					385						1015	180/225						245/370		515	
	YB132S1-2/5.5		1020	190	660	430				1095	450	400	210/240		315/430				30		543	4-φ24
	YB132S1-2/7.5					460							1095		450						400	
	YB160M1-2/11		1140	210	740	655				1240	490	440	255/240		385/485				30	585	4-φ24	
	YB160Mr2/15					655							1240		490					440		255/240
IH65-40-250	YB90S-4/1.1	95	1020	190	660	360	100	500	100	1060	450	400	155/225	180	190/340	30	265	490	515	4-φ24		
	YB90L-4/1.5					385				1080			180/225		245/370				535			
	YB100L1-4/2.2		1020	190	660	430				1130	400	180/225	245/370		30				538			
	YB100L1-4/3.0					460						1130	180/225						245/370		538	
	YB112M-4/4.0		1270	225	840	655				1355	540	490	255/240		385/485				30		625	4-φ24
	YB160M1-2/11					655							1355		540						490	
	YB160M-2/15		1270	225	840	695				1395	540	490	285/240		430/525				30	645	4-φ24	
	YB160L-2/18.5					695							1395		540					490		285/240
	YB180M-2/22		1420	250	940	730				1420	610	550	310/290		475/590				40	710	4-φ28	
YB200L1-2/30	803	1503				610	550	310/290	475/590				710	4-φ28								
IH65-40-315	YB100L-4/3.0	95	1140	210	740	430	125	500	100	1155	490	440	180/225	200	245/370	30	300	550	570	4-φ24		
	YB112M-4/4.0					460				1185			190/225		265/385				573			
	YB132S-4/5.5		1140	210	740	510				1235	440	210/240	315/430		30				598			
	YB132M-4/7.5					550						1275	210/240						315/430		598	
	YB160M-4/11		1270	225	840	655				1380	540	490	255/240		385/485				30		645	4-φ24
	YB160M-2/15					655							1380		540						490	
	YB160L-2/18.5		1270	225	840	695				1420	540	490	285/240		430/525				30	665	4-φ24	
	YB180M-2/22					695							1420		540					490		285/240
	YB200L1-2/30		1420	250	940	803				1528	610	550	310/290		475/590				40	730	4-φ28	
	YB200L-2/37					803							1528		610					550		310/290
	YB225M-2/45		840	1565	610	550				345/290	530/615	730	4-φ28									

产品型号	电机型号 功率 (Kw)	外形及安装尺寸																																			
		A	L1	L2	L3	L4	a	f	X	L5	B2	B3	B4/B5	h1	H2/h2'	h3	H	H1	H2	n-d																	
IH80-65-125	YB801-4/0.55	80	820	150	540	330	100	385	100	915	360	320	150/225	170/325	25	217	377	462	4-φ19																		
	YB802-4/0.75					360				945			155/225							190/340	467																
	YB90S-4/1.1					380				970			180/225							245/370	487																
	YB90L-4/1.5					430				1015			190/225							265/385	490																
	YB100L-2/3.0		1020	190	660	430				100	385	100	1015	390				350		180/225	245/370	30	315/430	30	217	377	487										
	YB112M-2/4.0					460							1045							190/225								265/385	490								
	YB132S1-2/5.5					510							1095							450/400								210/240	515								
	YB132S2-2/7.5					655							1240							490/440								255/240	557								
YB160M1-2/11	1140	210	740	655	100	385	100	1240	490				440	255/240	385/485	232	392	557	4-φ24																		
YB802-4/0.75	920	170	600	330				915						390						350	150/225						170/325	25	490								
YB90S-4/1.1				360				945													155/225							190/340		495							
YB90L-4/1.5				385				970													180/225							245/370		515							
YB100L1-4/2.2				430				1015	190/225	245/370	515																										
1噶132S1-2/5.5	1020	190	660	510				100	385	100	1095	450	400	210/240	315/430					30	315/430	30	245	425	543												
YB132S2-2/7.5				510							1095			450/400												210/240	543										
YB160MI-2/11				655							1240			490/440												255/240	585										
YB160M2-2/15				1140	210	740	655				585																										
YB90S-4/1.1	80	920	170	600	360	100	385				100	945	390	350	155/225	190/340	245	445	515						495	4-φ18.5											
YB90L-4/1.5					385							970			180/225												245/370	518									
YB100L1-4/2.2					430							1015			190/225												265/385	518									
YB100L2-4/3.0					460							1045			190/225												265/385	518									
YB112M-4/4.0					1020			190	660	510		100	385	100	1095	450				400	210/240	315/430	30	315/430	30		260	460	543								
YB132S2-2/7.5										510					1095						450/400									210/240	543						
YB160MI-2/11										655					1240						490/440									255/240	585						
YB160M2-2/15										1140					210						740									655	585						
YB160L-2/18.5	1140	210	740	695	100	385	100	1315	490	440	285/240				430/525	260	460	605	4-φ24																		
YB180M-2/22				730				1315			285/240									430/525	605																
YB100L1-4/2.2				1020				190			660									430	125	500				100			1155	450	400	180/225	245/370	265	490	535	535
YB100L2-4/3.0																				460									1185			190/225					
YB112M-4/4.0	510	1235	190/225						265/385	538																											
YB1325-415.5	550	1275	490/440						210/240	578																											
YB132M-4/7.5	1140	210	740	550				125	500	100	1275	490	440	210/240	315/430					280			505	578	4-φ24												
YB160M2-2/15				655							1380			255/240													385/485	625									
YB160L-2/18.5				695	1420	540/490	255/240				625																										
YB180M-2/22				730	1455	285/240	430/525				645																										
YB200L1-2/30	1420	250	940	803	125	500	100				1528	610	550	310/290	475/590	40	320	545	715																		
YB200L1-2/37				803							1528			310/290							475/590	715															
YB225M-2/45				840							1565			345/290							530/615	730															
YB100L1-4/2.2				1140							210			740							460	125			500	100	1135	490	440	190/225	265/385	30	325	605	598		
YB132S-4/5.5	510	1235	210/240					315/430	623																												
YB132M-4/7.5	550	1275	210/240					315/430	623																												
YB160M-4/11	655	1380	255/240					385/485	670																												
YB160L-4/15	1270	225	840	695				125	500	100	1420	540	490	255/240	385/485				40	345	625		670														
YB200L1-2/30				803	1528	310/290	475/590				755																										
YB200L2-2/37				840	1565	345/290	530/615				755																										
YB225M-2/45				840	1565	345/290	530/615				755																										
YB250M-2/55	1620	290	1060	935	125	500	100				1660	660	600	385/330	575/740	40	385	665				875															
YB280S-2/75				1010							1735			730/670									410/330	905													
YB250M-2/55	1820	320	1200	935							125	500	100	1660	660							600	385/330	575/740	40	385	665	875									
YB280S-2/75				1010										1735									730/670						410/330	905							

产品型号	电机型号	外形及安装尺寸																								
	功率(Kw)	A	L1	L2	L3	k	a	f	X	L5	B2	B3	B4/B5	h1	H2/h2'	h3	H	H1	H2	n-d						
IH100-80-125	YB802-4/0.75	95	920	170	600	330	100	385	100	915	390	350	150/225	160	170/325	30	245	425	490	4-φ19						
	YB90S-4/1.1					360				945			155/225		190/340				495							
	YB90L-4/1.5					385				970			180/225		245/370				515							
	YBI00L1-4/2.2					430				1015			190/225		265/385				518							
	YBI00L-4/3.0					460				1045			210/240		315/430				543							
	YBI12M-4/4.0					510				1095			210/240		315/430				543							
	YBI32S1-2/5.5					510				1095			450/400		210/240				315/430		245	425	543	4-φ24		
	YBI32S2-2/7.5					510				1240			490/440		255/240				385/485		30	260	440		585	
	YB160M1-2/11					655				1240			490/440		255/240				385/485		30	260	440		585	
YB160M2-2/15	655	1140	210	740	655	100	385	100	1240	490	440	255/240	160	385/485	30	260	440	585	4-φ24							
IH100-80-160	YB90L-4/1.5	95	1020	190	660	385	100	500	100	1085	450	400	155/225	160	190/340	30	245	445	495	4-φ24						
	YBI00L1-4/2.2					430				1130			180/225		245/370				515							
	YBI00L2-4/3.0					460				1160			190/225		365/385				518							
	YBI12M-4/4j0					510				1210			490/440		210/240				315/430		260	460	558			
	YBI32S-2/7.5					510				1210			490/440		210/240				315/430		260	460	558			
	YB160M1-2/11					655				1355			540		490				255/240		385/485	30	280	480	605	
	YB160M2-2/15					695				1395			540		490				255/240		385/485	30	280	480	605	
	YB160L-2/18.5					730				1430			610		550				285/240		430/525	40	300	500	625	
	YB180M-2/22					803				1503			610		550				310/290		475/590	40	300	500	690	4-φ28
YB200L1-2/30	803	1503	610	550	310/290	475/590	40	300	500	690	4-φ28															
IH100-65-200	YBI00L1-4/2.2	95	1140	210	740	430	100	500	140	1170	490	440	180/225	160	245/370	30	280	505	550	4-φ24						
	YBI00L-4/3.0					460				1200			190/225		265/385				553							
	YBI12M-4/4.0					510				1250			210/240		315/430				578							
	YBI32S-4/5.5					550				1290			210/240		315/430				578							
	YBI32M-4/7.5					550				1290			210/240		315/430				578							
	YB160M-2/15					655				1395			540		490				255/240		385/485	30	525	625		
	YB160L-2/18.5					695				1435			540		490				255/240		385/485	30	525	625		
	YB180M-2/22					730				1470			610		550				285/240		430/525	40	300	545	645	
	YB200L1-2/30					803				1543			610		550				310/290		475/590	40	300	545	710	4-φ28
YB200L2-2/37	803	1543	610	550	310/290	475/590	40	300	545	710	4-φ28															
YB225M-2/45	340	158C	610	550	345/290	530/615	320	545	710	4-φ28																
IH100-65-250	YBI00L2-4/3.0	110	1140	210	740	430	125	500	140	1195	490	440	180/225	200	245/370	30	300	550	570	4-φ24						
	YBI12M-4/4.0					460				1225			190/225		265/385				573							
	YBI32S2-4/5.5					510				1275			210/240		315/430				598							
	YBI32M-4/7.5					550				1315			210/240		315/430				598							
	YB160M-4/11					665				1420			540		490				255/240		385/485	320	570	645		
	YB160L1-4/15					695				1460			540		490				255/240		385/485	320	570	645		
	YB180M-2/22					730				1495			610		550				285/240		430/525	40	300	550	665	
	YB200L1-2/30					803				1570			610		550				310/290		475/590	40	340	590	736	
	YB200L2-2/37					803				1570			610		550				310/290		475/590	40	340	590	736	
	YB225M-2/45					870				1635			660		600				345/290		530/615	40	340	590	750	4-φ28
	YB250M-2/55					935				170C			660		600				385/290		575/740	40	360	610	850	
	YB280S-2/75					1010				1775			730		670				410/330		640/800	40	360	610	880	

产品型号	电机型号 功率(Kw)	外形及安装尺寸																		
		A	L1	L2	L3	k	a	f	X	L5	B2	B3	B4/B5	h1	h2/h2'	h3	H	H1	H2	n-d
IH100-65-315	YB132S-4/5.5	110	1270	225	840	510	125	530	140	1305	540	490	210/240	315/430	30	345	625	643	4-φ24	
	YB132M-4/7.5					550				1345										670
	YB160M-4/11					655				1450										770
	YB160L-4/15					695				1490										810
	YB180M-4/18.5					730				1525										850
	YB200L2-2/37					770				1560										890
	YB225M-2/45					870				1665										990
	YB250M-2/55					935				1730										1055
	YB280S-2/75					1010				1805										1130
	YB280M-2/90					1060				1855										1180
IH125-100-200	YB112M-4/4.0	110	1140	210	740	460	125	500	140	1225	490	440	190/225	265/385	30	300	580	573	4-φ24	
	YB132S-4/5.5					510				1275										623
	YB132M-4/7.5					550				1315										663
	YB160M-4/11					655				1420										768
	YB200L-2/30					803				1568										923
	YB200L2-2/37					840				1605										960
	YB225M-2/45					840				1605										960
	YB250M-2/55					935				1700										1055
YB280S-2/75	1010	1775	1130																	
IH125-100-250	YB132S-4/5.5	110	1270	225	840	510	140	530	140	1320	540	490	210/240	315/430	30	345	625	643	4-φ24	
	YB132M-4/7.5					550				1360										663
	YB160M-4/11					655				1465										768
	YB160L-4/15					695				1505										808
	YB180M-4/18.5					730				1540										848
	YB225M-2/45					840				1650										958
	YB250M-2/55					935				1745										1053
	YB280S-2/75					1010				1820										1128
	YB280M-2/90					1060				1870										1178
	IH125-100-315					YB160M-4/11				110										1270
YB160L-4/15		695	1505	735																
YB180M-4/18.5		730	1540	775																
YB180L-4/22		750	1560	795																
YB200L-4/30		803	1613	848																
YB225S-4/37		845	1655	890																
YB280S-2/75		1010	1820	1128																
YB280M-2/90		1060	1870	1178																
IH125-100-400	YB160L-4/15	130	1620	290	1060	695	140	530	140	1505	660	600	225/240	385/485	40	440	795	836	4-φ28	
	YB180M-4/18.5					730				1540										775
	YB180L-4/22					750				1560										795
	YB200L-4/30					803				1613										848
	YB225S-4/37					845				1655										890
	YB225M-4/45					870				1680										915
	YB250M-4/55					935				1745										980

产品型号	电机型号 功率 (Kw)	外形及安装尺寸																														
		A	L1	L2	L3	L4	a	f	X	L5	B2	B3	B4/B5	h1	h2/h27	h3	H	H1	H2	n-d												
IH150-125-250	YB160M-4/11	110	270	225	840	655	140	530	140	1465	540	490	255/240	250	385/485	30	370	725	695	4-φ24												
	YB160L-4/15		1420	250	940	695				1505	610	550									285/240	430/525	40	390	745	715						
	YB180M-4/18.5					730				1540			660		600				310/290							475/590	735					
	YB180L-4/22					750				1560																		310/290	475/590	780		
	YB220L-4/30					803				1613																					345/290	530/615
	YB225S-4/37					845				1655																						
IH150-125-315	YB180M-4/18.5	130	1620	290	1060	140	530	140	1540	660	600	285/240	280	430/525	40	440	775	785	4-φ28													
	YB180L-4/22								750											1560	310/290	475/S90	830									
	YB200L-4/30								803			1613		345/290				530/61S														
	YB225S-4/37								840			1650								38S/330				STS/740								
	YB225M-4/45								870			1680																				
	YB250M-4/55								935			1745																				
IH150-125-400	YB200L-4/30	110	1620	290	1060	140	530	140	1613	660	600	310/290	315	475/S90	40	475	875	865	4-φ28													
	YB225S-4/37								845											1655	325/290	S30/61S	965									
	YB225M-4/45								870			1680		385/330				575/740														
	YB250M-4/55								935			1745								410/330				640/800								
	YB280S-4/75								1010			1820													730	670						
	YB280M-4/90								1060			1870																				
IH200-150-250	YB180L-4/22	130	1620	290	1060	160	530	180	1620	660	600	51. SSP. 40	280	430/525	40	440	815	785	4-φ28													
	YB200L-4/30								803											1673	310/290	475/590	830									
	YB225S-4/37								840			1710		345/290				575/740														
	YB225M-4/45								870			1740								385/330				640/800								
	YB250M-4/55								935			1805													410/330	640/880						
	YB280S-4/75								1010			1880															730	670				
IH200-150-315	YB200L-4/30	130	1820	320	1200	160	670	180	1813	730	670	310/290	315	475/S90	40	475	875	865	4-φ28													
	YB225S-4/37								845											1855	34S/290	530/615	965									
	YB225M-4/45								870			1880		385/330				575/740														
	YB250M-4/55								935			1945								410/330				640/800								
	YB280S-4/75								1010			2020													730	670						
	YB280M-4/90								1060			2070																				
IH200-150-400	YB250M-4/55	130	1820	320	1200	160	670	180	1945	730	670	38S/330	315	575/740	40	475	925	965	4-φ28													
	YB280S-4/75								1010											2020	410/330	640/800										
	YB200M-4/90								1060			2070																				