

XP-SP25 Series

- Equipped with optical glass lens, sensing distance up to 25M.
- Removable glass lens, easy installation and maintenance.
- Good environmental resistance up to IP67.
- All product are CE approved.



Item	Specifications
Model number	XP-SP25MN
Sensing method	Through-beam
Sensing distance	25M
Switching output	NPN NO
Standard sensing object	Opaque 20mm
Operating voltage	DC 12~24V±10%
Response time	<25ms
Load current	<200mA
Light source	Infrared LED
Operation indicator	Red LED
Circuits protection	Reversed polarity & Short circuit protection
Enclosure protection	IEC IP67
Ambient temperature & humidity range	Operating : -20 ~ 55°C / RH 35 ~85% (with no icing or condensation)

Ambient illumination	Lamplight < 3500 Lux / Sunlight < 11000 Lux
Housing material	Case : ABS / Lens : Glass
Connecting method	Pre-wired 2M Cable
Accessories	Nuts

Dimension

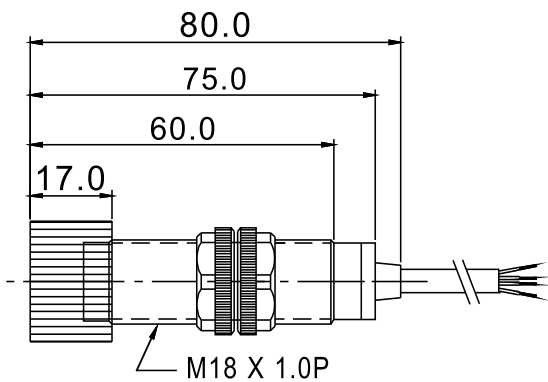

Wiring Diagram

Emitter of Thru-beam

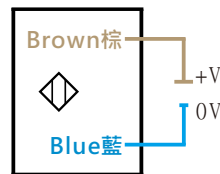

NPN NO Type

