

**Sub-Cell® GT
Agarose Gel
Electrophoresis
Systems**

Instruction Manual

**Catalog Numbers
170-4401 to 170-4406
170-4481 to 170-4486**

BIO-RAD

Warranty

Bio-Rad Laboratories warrants the Sub-Cell GT, Wide Mini-Sub[®] cell GT, and Mini-Sub cell GT electrophoresis systems against defects in materials and workmanship for 1 year. If any defects occur in the instrument during this warranty period, Bio-Rad Laboratories will repair or replace the defective parts free. The following defects, however, are specifically excluded:

1. Defects caused by improper operation.
2. Repair or modification done by anyone other than Bio-Rad Laboratories or an authorized agent.
3. Use of fittings or other spare parts supplied by anyone other than Bio-Rad Laboratories.
4. Damage caused by accident or misuse.
5. Damage caused by disaster.
6. Corrosion due to use of improper solvent or sample.

This warranty does not apply to parts listed below:

1. Platinum Electrode Wires

To insure the best performance from the Sub-Cell GT electrophoresis systems, become fully acquainted with these operating instructions before use. Bio-Rad recommends that you first read these instructions carefully. Assemble and disassemble the unit completely without casting a gel. After these preliminary steps, you should be ready to cast and run a gel.

Bio-Rad also recommends that all Sub-Cell GT system components and accessories be inspected for damage, cleaned as recommended in this manual, and rinsed thoroughly with distilled water before use.

Record the following for your records:

Model _____

Catalog No. _____

Date of Delivery _____

Warranty Period _____

Serial No. _____

Invoice No. _____

Purchase Order No. _____

For any inquiry or request for repair service, contact Bio-Rad Laboratories after confirming the model and serial number of your instrument.

Table of Contents

	Page
Section 1 General Information.....	1
1.1 Introduction	1
1.2 Safety	1
1.3 System Components.....	2
1.4 Specifications	4
Section 2 Operating Instructions	4
2.1 DNA Gel Preparation	4
2.2 Casting Agarose Gels	6
2.3 Electrophoresis	8
2.4 Nucleic Acid Staining and Visualization.....	9
2.5 Note on Blotting	10
Section 3 Gel and Electrophoresis Reagent Preparation	10
Section 4 Care and Maintenance.....	11
4.1 Cleaning Sub-Cell GT Components	12
4.2 Compatible Cleaning Agents	12
4.3 Maintenance Schedule	12
4.4 Electrode Replacement.....	13
4.5 RNase Decontamination	14
Section 5 Troubleshooting.....	14
Section 6 Product Information.....	15
6.1 Sub-Cell GT Systems.....	15
6.2 Sub-Cell GT System Accessories	16
6.3 Related Bio-Rad Products	18
Section 7 References	21

Section 1

General Information

1.1 Introduction

The Sub-Cell GT instruments (basic Sub-Cell GT cell, Wide Mini-Sub[®] cell GT, and Mini-Sub cell GT) comprise a comprehensive and flexible gel electrophoresis system that effectively separates nucleic acids using submerged agarose gels. Submarine agarose gels are easy to cast and readily dissipate heat. These gels allow sample underlaying and prevent electrical field discontinuities caused by wicks or sample well dehydration. Agarose gels are ideal for the separation of DNA restriction digestions, Polymerase Chain Reaction (PCR^{*})-amplified fragments, and genomic DNA and RNA prior to Southern or northern blotting. If operated correctly, agarose gel submarine electrophoresis can effectively separate nucleic acids from 20 base pairs to 20 kilobase pairs in length.

The Sub-Cell GT systems are designed for years of reproducible and rigorous use. These rugged systems incorporate many features that make casting and running agarose gels simple and efficient. The gel caster provides tape-free gel casting in trays. Gels can also be cast in the GT bases using specially designed wedge gates. Replaceable electrode cassettes provide a simple way to replace electrode wires. A comprehensive assortment of base and tray sizes, including a variety of preparative, analytical, and multichannel pipet compatible combs, makes these systems ideal for any agarose gel application.

Note: This manual contains instructions for the Sub-Cell GT electrophoresis systems only. Prior to the release of the Sub-Cell GT systems, Bio-Rad supplied similar agarose gel electrophoresis cells: the original Sub-Cell DNA electrophoresis cell, Wide Mini-Sub cell, and Mini-Sub cell systems. This manual does not provide information on these earlier versions. Contact your local Bio-Rad representative for information concerning the original Sub-Cell systems.

Definition of Symbols



Caution, risk of electrical shock



Caution (refer to accompanying documents)

1.2 Safety



The Sub-Cell GT electrophoresis systems are designed for maximum user safety. The buffer chambers are made of 3/16 inch (.476 cm) thick injection-molded acrylic to create a leak-free electrophoresis environment. The safety lids surround the buffer chamber to protect the user from exposure to electrical currents. All Sub-Cell GT systems were designed for indoor use only.

Before use, inspect the GT base for cracks or chips, which may allow the buffer to leak from the base and cause a potential electrical hazard. Additionally, inspect all electrical cables, banana jacks, and plugs for loose connections, cracks, breaks, or corrosion. Do not use any part that is cracked, charred, or corroded. These parts may also cause a potential electrical hazard. Contact your local Bio-Rad representative before using a part that may be considered hazardous.

During electrophoresis, inspect the base and workbench for any signs of buffer leakage. If leaking buffer is detected, disconnect the power to the cell immediately and contact your local Bio-Rad representative.

Power to Sub-Cell GT units is supplied by an external DC voltage power supply. This power supply must be ground isolated in such a way that the DC voltage output floats with

respect to ground. All of Bio-Rad’s power supplies meet this important safety requirement. The recommended power supply for this apparatus is the PowerPac 300 power supply. The PowerPac 300 power supply contains safety features such as no load, overload, rapid resistance change, and ground leak detection capabilities. The maximum specified operating parameters for the Sub-Cell GT systems are given in Table 1.1.

Table 1.1 Sub-Cell GT systems operating parameters

	Sub-Cell GT Cell	Wide Mini-Sub Cell GT	Mini-Sub Cell GT
Maximum voltage limit	200 VDC	150 VDC	150 VDC
Maximum power limit	40 Watts	45 Watts	10 Watts
Maximum Buffer temperature	40 °C	40 °C	40 °C

Current to the cell, provided from the external power supply, enters the unit through the lid assembly, providing a safety interlock. Current to the cell is broken when the lid is removed. Do not attempt to circumvent this safety interlock, and always turn the power supply off before removing the lid or when working with the cell.

Important: These Bio-Rad instruments are certified to meet IEC 1010-1** safety standards. IEC-certified products are safe to use when operated in accordance with the instruction manual. This instrument should not be modified in any way. Alteration of this instrument will:

- Void the manufacturer’s warranty
- Void the IEC 1010-1 safety certification
- Create a potential safety hazard

IEC 1010-1 certification applies to equipment designed to be safe between the operating temperatures of 4 °C and 40 °C and altitudes up to 2,000 meters. Instruments are also safe at a maximum relative humidity of 80% for temperatures up to 31 °C decreasing linearly to 50 % at 40 °C. Bio-Rad is not responsible for any injury or damage caused by the use of this instrument for purposes other than those for which it is intended, or by modifications of the instrument not performed by Bio-Rad or an authorized agent. No user-serviceable parts are contained in this apparatus. To insure electrical safety, do not attempt to service this apparatus.

1.3 System Components

Each of the Sub-Cell GT systems comes with the components listed in Table 1.2 (see Figure 1.1 for part description). Check your instrument to be sure all items are present. Note any damage to the unit which may have occurred during shipping. Notify Bio-Rad Laboratories if any items are missing or damaged.

Table 1.2 Sub-Cell GT System Components

Item	Sub-Cell GT System	Wide Mini-Sub Cell GT System	Mini-Sub Cell GT System
	Quantity	Quantity	Quantity
GT Base (buffer chamber)	1	1	1
Gel Casting Gates	2	2	2
Safety Lid and Cables	1	1	1
UVTP Gel Tray	1	1	1
Fixed Position Comb	2	2	2
	(15 well, 1.5 mm thick)	(15 well, 1.5 mm thick)	(8 well, 1.5 mm thick)
	(20 well, 1.5 mm thick)	(20 well, 1.5 mm thick)	(15 well, 1.5 mm thick)
Leveling Bubble	1	1	1
Gel Caster (optional)	1	1	1
Instruction Manual	1	1	1

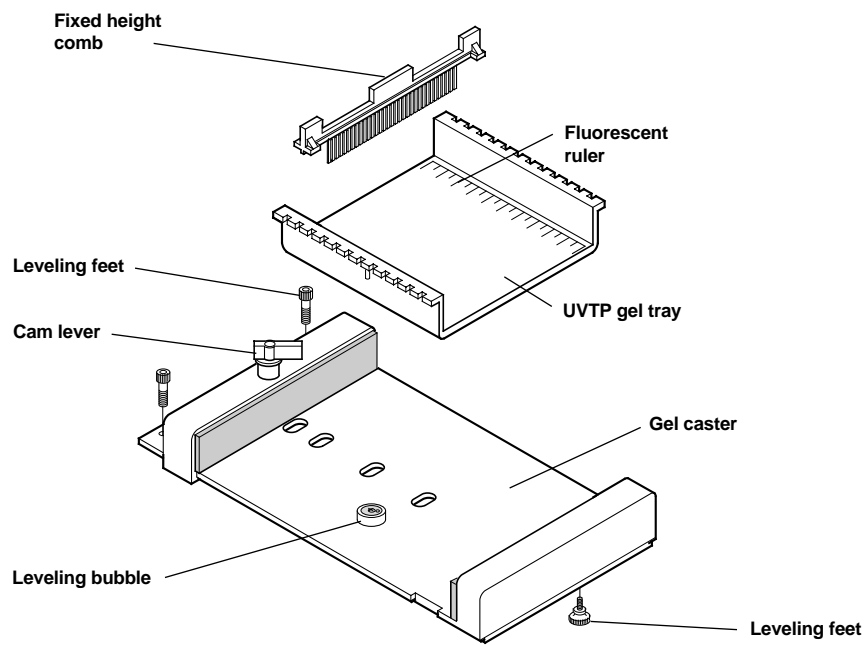
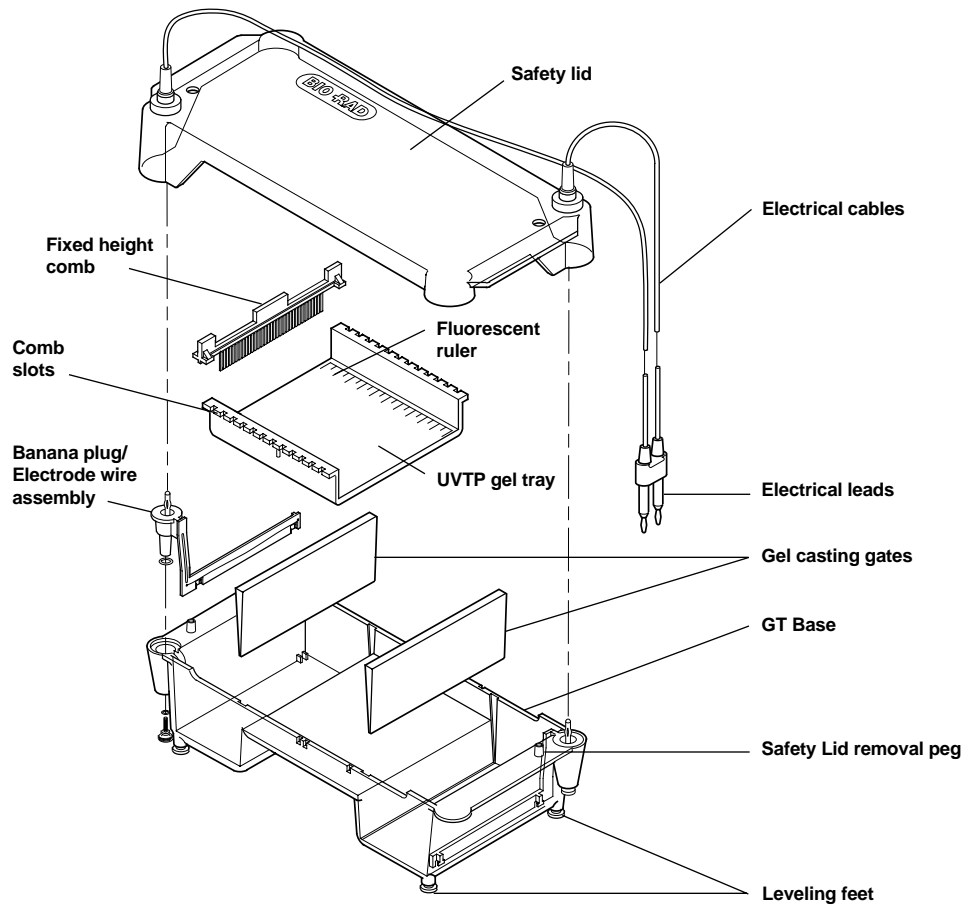

Fig.1.1. Sub-Cell GT parts.

1.4 Specifications

	Sub-Cell GT System	Wide Mini-Sub Cell GT System	Mini-Sub Cell GT System
GT base footprint (L x W x H)	42 x 19.5 x 10 cm	26 x 20 x 7.5 cm	26 x 12 x 6.5 cm
GT base buffer volume [†]	1,500–2,000 ml	650–900 ml	265–320 ml
GT base gel size	15 x 15 cm	15 x 7 cm	7 x 7 cm
Gel tray sizes	15 x 10 cm	15 x 7 cm	7 x 7 cm
	15 x 15 cm	15 x 10 cm	7 x 10 cm
	15 x 20 cm		
	15 x 25 cm		

Construction

GT base	Molded clear plastic
Gel casting gates	Aluminum
Safety lid	Molded clear plastic
Banana plug/electrode cassette	Molded polycarbonate
Banana plugs	Gold-plated brass, 4.4 cm length
Electrodes	Platinum, 0.25 mm diameter
Electrical cables	Dual, 20 AWG, tinned copper wire cable
	Flame-retardant polyurethane insulation jacket
Electrical leads	Nickel silver
Gel tray	UV-transparent acrylic plastic (UVTP)
Combs	Molded plastic and machined acrylic
Gel casting device	Polycarbonate
	0.64 cm silicon foam

[†] GT base buffer volumes will vary depending on the size and thickness of the gel used.

Section 2 Operating Instructions

Note: See Section 3, Gel and Electrophoresis Reagent Preparation, for information on the preparation of RNA gels. See References 1 and 2 for more information on DNA and RNA electrophoresis.

2.1 DNA Gel Preparation

DNA agarose gels can be used to separate and visualize DNA of various sizes. Before casting an agarose gel, consult Table 2.1 to determine the appropriate percent agarose gel to use, based on the size of DNA to be separated.

Procedure

1. Determine the amount of agarose (grams) required to make the desired agarose gel concentration and volume. Use Tables 2.1 and 2.2 as a guide for agarose concentration and gel volume requirements.

Example: For a 1% agarose gel, add 1 gram of agarose to 100 ml of 1x electrophoresis buffer.

Table 2.1 Gel Concentration Required for DNA Separation¹⁻²

Gel Concentration (%)	DNA Size (Kb)
0.50	1–30
0.75	0.8–12
1.00	0.5–10
1.25	0.4–7
1.50	0.2–3
2–5*	0.01–0.5

* Sieving agarose such as AmpliSize® agarose

Table 2.2 Gel Volume Requirements

Gel Size	0.25 cm thick	0.5 cm thick	0.75 cm thick	1.0 cm thick
Base				
7 x 7 cm	10 ml	20 ml	30 ml	40 ml
15 x 7 cm	20 ml	40 ml	60 ml	80 ml
15 x 15 cm	50 ml	100 ml	150 ml	200 ml
Tray				
7 x 7 cm	10 ml	20 ml	30 ml	40 ml
7 x 10 cm	15 ml	30 ml	45 ml	60 ml
15 x 7 cm	20 ml	40 ml	60 ml	80 ml
15 x 10 cm	30 ml	60 ml	90 ml	120 ml
15 x 15 cm	50 ml	100 ml	150 ml	200 ml
15 x 20 cm	70 ml	140 ml	210 ml	280 ml
15 x 25 cm	90 ml	180 ml	270 ml	360 ml

2. Add the agarose to a suitable container (*e.g.*, 250 ml Erlenmeyer flask, Wheaton bottle, etc.). Add the appropriate amount of 1x electrophoresis buffer (see Section 3, Gel and Electrophoresis Reagent Preparation, for electrophoresis buffer preparation) and swirl to suspend the agarose powder in the buffer. If using an Erlenmeyer flask, invert a 25 ml Erlenmeyer flask into the open end of the 250 ml Erlenmeyer flask containing the agarose. The small flask acts as a reflux chamber, allowing long or vigorous boiling without much evaporation.

Note: A mark can be put on the lower flask at the same level as the liquid. If evaporation occurs, water can be added to bring the liquid back to the original starting level.

3. The agarose can be melted by boiling on a magnetic hot plate (Step 4a) or in a microwave oven (Step 4b).

Caution: Always wear protective gloves, goggles, and a lab coat while preparing and casting agarose gels. The vessels containing hot agarose can cause severe burns if allowed to contact skin. Additionally, molten agarose can boil over when swirled.

Magnetic Hot Plate Method

- 4a. Add a stir bar to the undissolved agarose solution. Heat the solution to boiling while stirring on a magnetic hot plate. Bubbles or foam should disrupt before rising to the neck of the flask.

Microwave Oven Method

- 4b. Place the gel solution into the microwave. Using a low to medium setting, set the timer for a minimum of 5 minutes, stopping the microwave oven every 30 seconds and swirling the flask gently to suspend the undissolved agarose. This technique is the fastest and safest way to dissolve agarose.
5. Boil and swirl the solution until all of the small translucent agarose particles are dissolved. With the small flask still in place, set aside to cool to 60 °C before pouring.

2.2 Casting Agarose Gel Slabs

There are several ways to cast agarose submarine gels using the Sub-Cell GT systems. Gels may be cast with or without a UV-transparent plastic (UVTP) tray directly on the stage of the Sub-Cell GT bases using the gel casting gates. Gels may also be cast on the removable UVTP trays with the aid of the gel caster or with standard laboratory tape.

Casting gels on the base stages

1. Level the Sub-Cell base using the leveling bubble provided.
2. Slide the gel casting gates into the slots at opposite ends of the gel stage.
3. Place the comb(s) into the appropriate slot(s) of the base so that the sample wells are near the cathode (black). DNA samples will migrate toward the anode (red) during electrophoresis.
4. Prepare the desired concentration and amount of agarose in 1x electrophoresis buffer (see Section 2.1). When the agarose solution has cooled to 50–60 °C pour the molten agarose between the gates.

Warning: Hot agarose (>60 °C) may cause the plastic in the cell to warp or craze and will decrease the lifetime of the Sub-Cell base. Warping may also result in sample wells of uneven depth.

5. Allow 20–40 minutes for the gel to solidify at room temperature.
6. Carefully remove the comb from the solidified gel. Remove the gel casting gates.
7. Submerge the gel beneath 2 to 6 mm of 1x electrophoresis buffer (see Section 3, Gel and Electrophoresis Reagent Preparation). Use greater depth overlay (more buffer) with increasing voltages to avoid pH and heat effects.

Casting Gels on the Base Stage With UVTP Tray

1. Level the cell using the leveling bubble provided.
2. Place the UVTP tray on the cell base stage.

Note: The Mini-Sub cell GT requires the 7 x 7 cm UVTP tray for casting in the base. The Wide-Mini-Sub cell GT requires the 15 x 7 cm UVTP tray and the Sub-Cell GT system requires the 15 x 15 cm UVTP tray for casting in the base.

3. Slide the gel casting gates into the slots at opposite ends of the base stage. Insure the gates are evenly seated in the slots and the gates uniformly contact all edges of the UVTP tray. The weight of the gates provides a tight seal to prevent any leakage problems during gel casting.
4. Place the comb(s) into the appropriate slot(s) of the trays so that the sample wells are near the cathode (black). DNA samples will migrate toward the anode (red) during electrophoresis.
5. Prepare the desired concentration and amount of agarose in 1x electrophoresis buffer (see Section 2.1). When the agarose solution has cooled to 50-60 °C, pour the molten agarose between the gates.

Warning: Hot agarose (>60 °C) may cause the tray to warp or craze and will decrease the lifetime of the tray. Warping may also result in sample wells of uneven depth.

6. Allow 20-40 minutes for the gel to solidify at room temperature.
7. Carefully remove the comb from the solidified gel. Remove the gel casting gates.
8. Submerge the gel beneath 2 to 6 mm of 1x electrophoresis buffer (see Section 3, Gel and Electrophoresis Reagent Preparation). Use greater depth overlay (more buffer) with increasing voltages to prevent pH and heat effects.

Removable tray (UVTP) gel casting using a Gel Caster or Mini-Gel Caster

1. Level the Gel Caster or Mini-Gel Caster using the leveling feet in the gel caster and the leveling bubble provided.
2. Disengage and slide the movable wall to the open end of the Gel Caster or Mini-Gel Caster by turning and lifting the cam peg upward.

Note: If casting more than one gel with the Gel Caster, add the removable gel casting wall to the gel caster. The removable wall will allow casting of two 15 x 10 cm trays, four 7 x 10 cm trays or one 15 x 10 cm and one 15 x 15 cm trays.

3. Place the open edge of the UVTP tray against the fixed wall of the Gel Caster or Mini-Gel Caster.
4. Slide the movable wall against the edge of the UVTP tray (Figure 2.1).
5. To seal the open tray ends, engage the cam peg by turning and pressing downward simultaneously.
6. When the cam peg has dropped into the appropriate slot, turn the peg in either direction until resistance is felt. This action seals the edges of the tray for casting.
7. Place the comb(s) into the appropriate slot(s) of the tray.

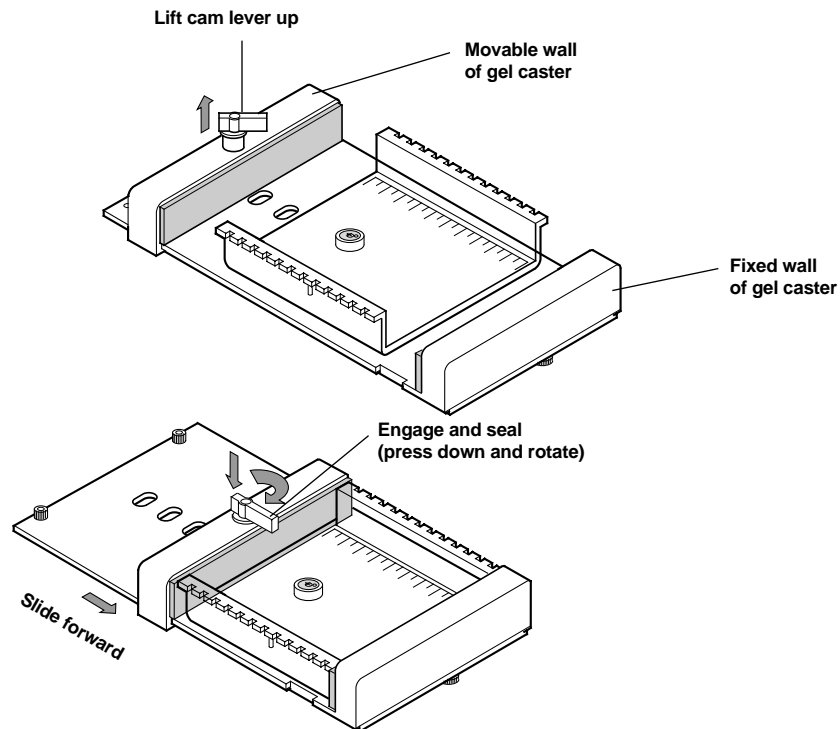

Fig. 2.1. Sealing the UVTP tray for gel casting.

8. Prepare the desired concentration and amount of agarose in 1x electrophoresis buffer (see Section 2.1). When the agarose solution has cooled to 50–60 °C pour the molten agarose between the gates.

Warning: Hot agarose (>60 °C) may cause the tray to warp or craze and will decrease the lifetime of the tray. Warping may also result in sample wells of uneven depth.

9. Allow 20–40 minutes for the gel to solidify at room temperature.
10. Carefully remove the comb from the solidified gel.
11. Disengage the cam peg by turning and lifting upward. Slide the movable wall away from the tray. Remove the tray from the Gel Caster or Mini-Gel Caster.

Note: While the gel is solidifying, a light seal is formed between the gasket and the gel (especially for low percentage agarose gels [$<0.8\%$]). Before moving the wall away from the tray, carefully lift the tray on one side to release the seal or use a spatula to break the seal between the agarose and gasket.

12. Place the tray onto the leveled Sub-Cell base so that the sample wells are near the cathode (black). DNA samples will migrate toward the anode (red) during electrophoresis.
13. Submerge the gel beneath 2 to 6 mm of 1x electrophoresis buffer (see Section 3, Gel and Electrophoresis Reagent Preparation). Use greater depth overlay (more buffer) with increasing voltages to avoid pH and heat effects.

Removable tray (UVTP) gel casting using tape

1. Seal the ends of the UVTP gel tray securely with strips of standard laboratory tape. Press the tape firmly to the edges of the gel tray to form a fluid-tight seal.
2. Level the gel tray on a leveling table or workbench using the leveling bubble provided with the instrument.
3. Prepare the desired concentration and amount of agarose in 1x electrophoresis buffer (see Section 2.1). When the agarose solution has cooled to 50–60 °C pour the molten agarose into the gel tray.

Warning: Hot agarose (>60 °C) may cause the tray to warp or craze and will decrease the lifetime of the tray. Warping may also result in sample wells of uneven depth.

4. Allow 20–40 minutes for the gel to solidify at room temperature.
5. Carefully remove the comb from the solidified gel.
6. Remove the tape from the edges of the gel tray.
7. Place the tray onto the leveled Sub-Cell base so that the sample wells are near the cathode (black). DNA samples will migrate toward the anode (red) during electrophoresis.
8. Submerge the gel under 2 to 6 mm buffer (see Section 3, Gel and Electrophoresis Reagent Preparation). Use greater depth overlay (more buffer) with increasing voltages to avoid pH and heat effects.

2.3 Electrophoresis

After the agarose gel has solidified, sample loading and electrophoresis can begin. Agarose gels can be run in many different types of electrophoresis buffers. Nucleic acid agarose gel electrophoresis is usually conducted with either Tris-Acetate-EDTA (TAE) buffer or Tris-Borate-EDTA (TBE) buffer. While TAE buffer provides faster electrophoretic migration of linear DNA and better resolution of supercoiled DNA, TBE buffers have a stronger buffering capacity for longer or higher voltage electrophoresis runs. Bio-Rad offers premixed 50x TAE and 10x TBE buffers, as well as individual buffer reagents for use with the Sub-Cell GT systems.

1. Prepare samples for gel loading. The maximum sample loading volumes for Bio-Rad's combs are listed in Section 6.2. Loading volume is dependent upon the type of comb used (*i.e.*, well thickness and length) and thickness of the gel.

- When loading volume is determined, add standard nucleic acid sample loading dye to a final 1x concentration to make samples dense for underlaying into sample wells (see Section 3, Gel and Electrophoresis Reagent Preparation, for sample loading dye preparation).
- Load the samples into the wells using standard pipets. Multichannel pipets can be used for loading samples only with the Bio-Rad MP combs (see Section 6.2).

Note: Sample wells are often difficult to see. Well visualization can be enhanced by placing black paper or tape under the base or trays where comb placement or well formation is common.

- Place the lid on the DNA cell carefully. Do not disturb the samples. The Sub-Cell GT system lids attach to the base in only one orientation. To attach the lid correctly, match the red and black banana jacks on the lid with the red and black banana plugs of the base.
- Power requirements vary depending on gel thickness, length and concentration, and type of electrophoresis buffer used. Refer to Tables 2.3 and 2.4 for relative sample migration rates and for DNA size migration with sample loading dyes for the different Sub-Cell GT systems.

Note: Buffer recirculation is not required for most standard DNA and RNA agarose gel electrophoresis. If buffer recirculation is required, simply turn off the power supply, remove the safety lid, and mix the running buffer as desired. After the buffer has been mixed, reconnect the safety lid and continue electrophoresis.

Table 2.3 Relative Sample Migration Rates*

Cell Type	Voltage	Bromophenol Blue Migration Rate
Sub-Cell GT cell, 15 x 15 cm gel	75 V	3.0 cm/hr
Wide Mini-Sub cell GT, 15 x 10 cm gel	75 V	4.5 cm/hr
Mini-Sub cell GT, 7 x 10 cm gel	75 V	4.5 cm/hr

* These sample migration rates were determined based on a 0.5 cm thick 1.0% agarose gel using Bio-Rad's Molecular Biology Certified Agarose in 1x TAE electrophoresis buffer (diluted from Bio-Rad's Premixed 50x TAE Buffer). Migration rates will vary depending on the voltage, current, and type of agarose or buffer used.

Table 2.4 DNA size migration with sample loading dyes

Agarose Concentration (%)	Xylene Cyanol	Bromophenol Blue
0.5–1.5	4–5 Kb	400–500 bp
2.0–3.0**	750 bp	100 bp
4.0–5.0**	125 bp	25 bp

** Sieving agarose such as AmpliSize agarose.

2.4 Nucleic Acid Staining and Visualization

Gels can be removed from the base or gel tray for nucleic acid staining. The gel can also remain on the UVTP gel tray for staining.

Ethidium Bromide Staining Procedure

- Place the gel into the appropriate volume of 0.5 µg/ml ethidium bromide (EtBr) stain for 15–30 minutes. Use enough staining solution to cover the entire gel.

Caution: Ethidium bromide is a suspected carcinogen and should be handled with extreme care. Always wear gloves, eye glasses, and a laboratory coat. Dispose of used EtBr solutions and gels appropriately (Review EtBr Material Safety Data Sheet [MSDS] for proper disposal methods).

- Destain the gel for 10–30 minutes in dH₂O using the same volume used for staining.

Note: Ethidium Bromide can be removed from the DNA with extended destaining. This will cause lower sensitivity of detection. However, insufficient destaining will create higher background fluorescence.

- Rinse the gel briefly with dH₂O to remove any residual staining solution.
- Place the gel on a UV transilluminator for nucleic acid visualization and analysis. DNA-Ethidium Bromide complexes may be illuminated with UV light of 254, 302, or 366 nm. Sensitivity decreases with illumination at higher wavelengths. However, nicking of DNA will increase below 302 nm. Table 2.5 gives the percentage of transmittance of UV light through 1/4" (.64 cm) UV-transparent plastic.

Note: Nucleic acids in the gel can be visualized through the UVTP trays. If a UVTP tray is not used, place household plastic wrap between the UV transilluminator and the gel to avoid contaminating the transilluminator with nucleic acids or EtBr.

Table 2.5 Percent UV Transmittance through 1/4" (.64 cm) UV Transparent Plastic (UVTP)

Wavelength (nm)	Approximate % Transmittance
254	0
302	80
360	90

- Photograph the gel using standard cameras and film (*e.g.*, Bio-Rad's Standard Polaroid Gel Documentation System) or with CCD-based digitized image analysis systems (*e.g.*, Gel Doc™ 1000 UV fluorescent gel documentation system). Gels are generally photographed with a yellow, orange, or red interference filter. Red filters generally give the cleanest background. Bio-Rad offers a full-line of standard photography and CCD-based imaging systems for nucleic acid gel analysis.

2.5 Note on Blotting

Nucleic acids within the gel can be transferred to membranes using the techniques of Southern and Northern blotting. It is beyond the scope of this instruction manual to include blotting procedures. Consult references 1 and 2 for blotting techniques. Bio-Rad offers a full line of nitrocellulose and positively charged nylon membranes, as well as vacuum and electrophoretic blotting apparatus for Southern and Northern blotting.

Section 3 Gel and Electrophoresis Reagent Preparation

RNA Agarose Formaldehyde Gels

For 100 ml of a 1% agarose formaldehyde gel prepare as follows:

- 62 ml of 1.6% melted agarose
- 20 ml 5x MOPS electrophoresis buffer (1x final concentration)
- 18 ml 12.3 M (37.5%) formaldehyde (2.2 M final concentration)

Caution: Formaldehyde solutions and formaldehyde vapors are toxic. When handling solutions or gels that contain formaldehyde use a chemical hood. Always wear gloves, eye glasses, and a laboratory coat while using formaldehyde. See the MSDS for safety information.

Nucleic Acid Electrophoresis Buffers¹⁻²

DNA agarose gel electrophoresis is usually conducted with either Tris-Acetate-EDTA (TAE) or Tris-Boric Acid-EDTA (TBE). While TAE provides faster electrophoretic migration of linear DNA and better resolution of supercoiled DNA, TBE buffers have a stronger buffering capacity for longer or higher voltage electrophoresis runs. Bio-Rad offers premixed 50x TAE and 10x TBE buffers for use with the Sub-Cell GT systems. RNA formaldehyde gels require a MOPS [3-(N-morpholino)-propanesulfonic acid] electrophoresis buffer.

1x Tris-Acetate-EDTA (TAE)—40 mM tris (pH 7.6), 20 mM acetic acid, and 1 mM EDTA.

50x Stock (1 liter)—dissolve in 600 ml distilled water:
242 g tris base (FW = 121)
57.1 ml glacial acetic acid
100 ml 0.5 M EDTA (pH 8.0).
Fill to a final volume of 1 liter with distilled water.

1x Tris-Boric Acid-EDTA (TBE)—89 mM tris (pH 7.6), 89 mM boric acid, 2 mM EDTA

10x Stock (1 liter)—dissolve in 600 ml distilled water:
108 g tris base (FW = 121)
55 g boric acid (FW = 61.8)
40 ml 0.5 M EDTA (pH 8.0)
Fill to a final volume of 1 liter with distilled water.

1x MOPS Buffer (RNA Gels)—0.02 M MOPS [3-(N-morpholino)-propanesulfonic acid] (pH 7.0), 8 mM sodium acetate, 1 mM EDTA (pH 8.0)

5x Stock (1 liter)—dissolve in 600 ml DEPC-treated distilled water:
20.6 g MOPS
13.3 ml 3 M sodium acetate (DEPC treated), pH 7.4
10 ml 0.5 M EDTA (DEPC-treated), pH 8.0
Fill to a final volume of 1 liter with DEPC-treated distilled water.

Caution: DEPC is a suspected carcinogen. Always wear gloves, eye glasses, and a laboratory coat. Use caution when handling DEPC containing solutions. Consult the DEPC MSDS (Material Safety Data Sheet) for more information.

DNA and RNA Sample Loading Dye¹⁻²

A convenient 10x sample buffer stock consists of 50% glycerol, 0.25% bromophenol blue, and 0.25% xylene cyanole FF in 1x TAE buffer. Only 1–10 ml of the 10x loading dye should be prepared.

RNA Sample Preparation¹⁻²

Prior to loading RNA onto an agarose formaldehyde gel prepare each RNA sample as follows:
6 µl RNA in DEPC-treated water
10 µl 5x MOPS buffer (final concentration 1.67x)
9 µl 12.3 M formaldehyde (final concentration 3.7 M)
25 µl formamide (final concentration 50% v/v)

Caution: Formamide is a teratogen. Always wear gloves, eye glasses, and a laboratory coat. Use caution when handling formamide. Consult the formamide MSDS for more information.

Ethidium Bromide Solution

Add 10 mg of EtBr to 1 ml distilled water. Bio-Rad offers EtBr solutions (10 mg/ml).

Section 4 Care and Maintenance

4.1 Cleaning Sub-Cell GT Components

1. All Sub-Cell GT system parts should be washed with a mild detergent solution in warm water.
Note: Be careful not to snag or break the electrode wire in the GT base while cleaning.
2. Rinse all parts thoroughly with warm water or distilled water and air dry, if possible.

4.2 Compatible Cleaning Agents

Chemically compatible cleaners must be used to insure long life of parts. These include:

- **Aqueous solutions of soaps and mild detergents:**
Bio-Rad Cleaning Concentrate (catalog number 161-0722)
Dishwashing liquid
- **Organic Solvents:**
Hexane
Aliphatic hydrocarbons

Do not leave plastic parts to soak in detergents more than 30 minutes. A short detergent rinse typically is all that is required.

Caution: Do not use the following chemicals to clean Sub-Cell GT parts. Exposure to these chemicals may cause the plastic parts to crack, craze, etch, or warp.

- **Chlorinated Hydrocarbons**
Carbon tetrachloride
Chloroform
- **Aromatic Hydrocarbons**
Benzene
Phenol
Toluene
Methyl ethyl ketone
Acetone
- **Alcohols**
Methanol
Ethanol
Isopropyl alcohol

Do not use abrasive or highly alkaline cleaners on Sub-Cell GT parts.

Do not expose Sub-Cell GT parts to temperatures $>60^{\circ}\text{C}$. Do not sterilize Sub-Cell GT parts by autoclaving or dry heat.

4.3 Maintenance Schedule

Item	Look For	Frequency	Action
All parts	Dried salts, agarose, grease, and dirt	Each use	Clean parts as described in Section 4.1
Electrical cables	Breaks or fraying	Each use	Replace cables
Trays	Chips or cracks	Each use	Replace tray
Electrode wires	Breaks	Each use	See Section 4.4 (Electrode Cassette Replacement)
Cable connections (banana jacks and plugs)	Looseness	Weekly	Replace banana jacks or banana plug holders
GT base	Crazing, cracks, or leaks	Monthly	Replace GT base or banana plug holder o-ring

4.4 Electrode Replacement

The Sub-Cell GT systems allow easy replacement of broken electrode wires by removing the banana plug/electrode wire assembly and ordering a new assembly from Bio-Rad (Figure 4.1). Order the new assembly using the part description and catalog numbers listed in Section 6, Product Information.

1. Remove the thumb screw and rubber gasket from the banana plug chamber of the GT base to release the banana plug/electrode wire assembly. Do not discard this thumb screw or rubber gasket (keep these parts with the GT base).
2. Remove the broken wire assembly by lifting upward on the banana plug. Discard the broken assembly.
3. Insert the new assembly into the banana plug chamber of the GT base. Make sure the electrode wire guard guides are properly seated into the electrode wire guard slots in the bottom of the GT base.
4. Replace and tighten the thumb screw and rubber gasket to secure the assembly in the base and to form a leak-free seal in the banana plug holder chamber.

Note: Test for buffer leakage, by filling the base with water and checking for leakage of water through the banana plug chamber of the base. If leakage occurs, tighten the thumb screw.

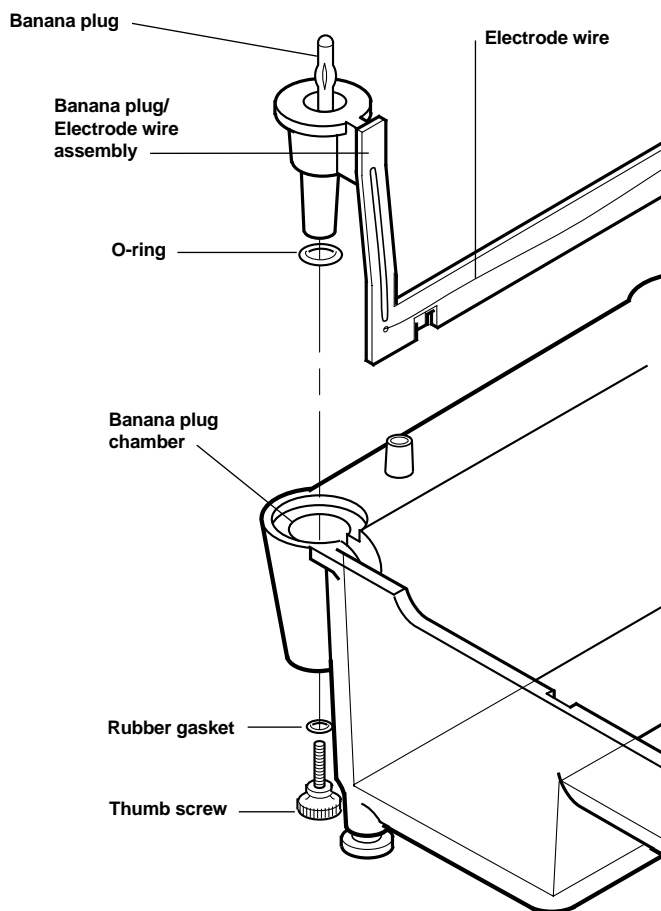

Fig. 4.1. Removal of banana plug/electrode wire assembly.

4.5 RNase Decontamination

Sub-Cell GT parts can be cleaned with a mild detergent and treated for 10 minutes with 3% hydrogen peroxide (H₂O₂), and then rinsed with 0.1% DEPC- (diethyl pyrocarbonate) treated distilled water, to eliminate RNases prior to using the Sub-Cell GT systems for RNA gels.¹⁻² Consult references 1-2 for other suggestions regarding the use of DEPC in RNase decontamination.

Caution: DEPC is a suspected carcinogen. Always wear gloves, eye glasses, and a laboratory coat. Use caution when handling DEPC-containing solutions. Consult the DEPC MSDS for more information.

Do not attempt to RNase decontaminate Sub-Cell GT parts using extreme dry heat.

Note: Several commercial products are available for eliminating RNase contamination. RNaseZAP™ (Ambion) is a safe, simple, and effective method that if used properly does not craze or fog the Sub-Cell GT parts. See manufacturer's instructions for proper use.

Section 5 Troubleshooting

Symptoms	Cause	Solutions
Slanted lanes (bands)	Gel not fully solidified Comb warped or at an angle	Let gel solidify for at least 30–45 minutes. Check alignment of comb.
Curved line or distortion of lanes (bands)	Bubbles in sample wells	Remove bubbles prior to electrophoresis.
Differential relative mobilities	Sample spilled out of wells	Samples should have proper density. Apply carefully.
	Unit not leveled	Level unit. Place on steady work bench.
Curved bands, smiles	Sample overload	Reduce load.
Ragged bands	Sample density incorrect	See sample application instructions.
	Sample well deformed	Carefully remove comb, especially from soft gels. Be sure gel has solidified. Cooling soft gels aids in comb removal.
Band smearing and streaking	Excessive power or heating	Reduce voltage. See electrophoresis instructions.
	Agarose has improper endosmosis (m _p)	Consult Bio-Rad about agarose.
	Salt concentration in sample too high	Reduce salt concentration to ≤ 0.1 M.
	Excessive power and heating	Reduce voltage. See electrophoresis instructions.
	Sample spilled out of well	Apply sample carefully. Increase gel thickness for large sample volumes. Adjust comb height.
	Incomplete digest, nuclease contamination, bad enzyme	Heat sample. Check enzyme activity. Digest sample further.

Symptoms	Cause	Solutions
	Sample wells cast through the gel. Sample leaks along bottom of running surface.	Comb should be placed 1 to 2 mm above the base of the running surface.
	Sample overload	Dilute sample.
Bands sharp but too few bands seen	Too high gel percentage	Lower gel percentage.
	Incomplete digest	Check enzyme activity, digest further.
High MW bands sharp; Low MW bands smeared	Gel percentage too low	Increase gel percentage. Switch to polyacrylamide.
Gels crack	Too high voltage gradient, especially with low melting temperature agarose or low gel strength gels	Reduce voltage. Run gel at lower temperature.

Section 6 Product Information

6.1 Sub-Cell GT Systems

Catalog Number	Product Description
170-4401	Sub-Cell GT System , with 15 x 10 cm tray
170-4402	Sub-Cell GT System , with 15 x 15 cm tray
170-4403	Sub-Cell GT System , with 15 x 20 cm tray
170-4404	Sub-Cell GT System , with 15 x 25 cm tray
170-4481	Sub-Cell GT System , with 15 x 10 cm tray and gel caster
170-4482	Sub-Cell GT System , with 15 x 15 cm tray and gel caster
170-4483	Sub-Cell GT System , with 15 x 20 cm tray and gel caster
170-4484	Sub-Cell GT System , with 15 x 25 cm tray and gel caster
170-4405	Wide Mini-Sub Cell GT System
170-4485	Wide Mini-Sub Cell GT System , with gel caster
170-4406	Mini-Sub Cell GT System
170-4486	Mini-Sub Cell GT System , with gel caster
Sub-Cell GT/PowerPac 300 Power Supply Systems*	
165-4349	Sub-Cell GT/PowerPac 300 System , 100/120 V
165-4350	Sub-Cell GT/PowerPac 300 System , 220/240 V
165-4348	Wide Mini-Sub Cell GT/PowerPac 300 System , 100/120 V
165-4351	Wide Mini-Sub Cell GT/PowerPac 300 System , 220/240 V
165-4347	Mini-Sub Cell GT/PowerPac 300 System , 100/120 V
165-4352	Mini-Sub Cell GT/PowerPac 300 System , 220/240 V

* All Sub-Cell GT/PowerPac 300 systems come with 15 x 15 cm UVTP tray and gel caster.

6.2 Sub-Cell GT System Accessories

Catalog Number	Product Description
Sub-Cell GT Systems	
170-4410	Sub-Cell GT Base
170-4411	Sub-Cell GT Safety Lid with Cables
170-4412	Gel Caster
170-4413	Sub-Cell GT Electrode (Anode), red
170-4414	Sub-Cell GT Electrode (Cathode), black
170-4415	Sub-Cell GT Gel Casting Gates
170-4416	GT UVTP Gel Tray, 15 x 10 cm
170-4417	GT UVTP Gel Tray, 15 x 15 cm
170-4418	GT UVTP Gel Tray, 15 x 20 cm
170-4419	GT UVTP Gel Tray, 15 x 25 cm
Wide Mini-Sub Cell GT Systems	
170-4420	Wide Mini-Sub Cell GT Base
170-4421	Wide Mini-Sub Cell GT Safety Lid with Cables
170-4422	Mini-Gel Caster
170-4423	Wide Mini-Sub Cell GT Electrode (Anode), red
170-4424	Wide Mini-Sub Cell GT Electrode (Cathode), black
170-4425	Wide Mini-Sub Cell GT Gel Casting Gates
170-4416	GT UVTP Gel Tray, 15 x 10 cm
170-4426	GT UVTP Gel Tray, 15 x 7 cm
Mini-Sub Cell GT Systems	
170-4430	Mini-Sub Cell GT Base
170-4431	Mini-Sub Cell GT Safety Lid with Cables
170-4422	Mini-Gel Caster
170-4432	Mini-Sub Cell GT Electrode (Anode), Red
170-4433	Mini-Sub Cell GT Electrode (Cathode), Black
170-4434	Mini-Sub Cell GT Gel Casting Gates
170-4435	GT UVTP Gel Tray, 7 x 10 cm
170-4436	GT UVTP Gel Tray, 7 x 7 cm

Sub-Cell Systems Combs**Fixed Height Combs For Sub-Cell GT and Wide Mini-Sub Cell GT Systems**

Catalog Number	Well Number	Thickness (mm)	Well Width (mm)	Well Volume Capacity* (µl)
170-4440	1	1.50	106.43	800.0
170-4441	2	1.50	50.29	377.0
170-4442	4	1.50	26.42	200.0
170-4443	10	0.75	9.87	37.0
170-4444	10	1.50	9.87	74.0
170-4445	15	0.75	5.52	20.7
170-4446	15	1.50	5.52	41.4
170-4447	20	0.75	4.84	18.2
170-4448	20	1.50	4.84	36.4
170-4449	30	1.50	2.69	20.2

Multi-channel Pipet Compatible (MP) Fixed Height Combs For Sub-Cell GT and Wide Mini-Sub Cell GT Systems

Catalog Number	Well Number	Thickness (mm)	Well Width (mm)	Well Volume Capacity* (µl)
170-4450	10	0.75	5.82	21.8
170-4451	10	1.50	5.82	43.6
170-4452	14	0.75	5.82	21.8
170-4453	14	1.50	5.82	43.6
170-4454	18	0.75	2.91	10.9
170-4455	18	1.50	2.91	21.8
170-4456	26	0.75	2.91	10.9
170-4457	26	1.50	2.91	21.8

Adjustable Height Combs For Sub-Cell GT and Wide Mini-Sub Cell GT Systems (Adjustable height combs require a comb holder [catalog 170-4320])

Catalog Number	Well Number	Thickness (mm)	Well Width (mm)	Well Volume Capacity* (µl)
170-4328	1	1.50	106.43	800.0
170-4345	2	1.50	50.29	377.0
170-4325	10	0.75	9.87	37.0
170-4326	10	1.50	9.87	74.0
170-4323	15	0.75	5.52	20.7
170-4324	15	1.50	5.52	41.4
170-4321	20	0.75	4.84	18.2
170-4322	20	1.50	4.84	36.4
170-4344	30	1.50	2.69	20.2

Fixed Height Combs for Mini-Sub Cell GT

Catalog Number	Well Number	Thickness (mm)	Well Width (mm)	Well Volume Capacity* (µl)
170-4460	1	1.50	43.43	325.7
170-4461	2	1.50	20.32	152.4
170-4462	8	0.75	5.54	20.8
170-4463	8	1.50	5.54	41.6
170-4464	15	0.75	2.59	9.7
170-4465	15	1.50	2.59	19.4

Adjustable Height Combs for Mini-Sub Cell GT (Adjustable height combs require a comb holder [catalog 170-4331])

Catalog Number	Well Number	Thickness (mm)	Well Width (mm)	Well Volume Capacity* (µl)
170-4342	1	1.50	43.43	325.7
170-4333	8	1.50	5.54	41.6
170-4332	15	1.50	2.59	19.4

* Well volume capacity was determined based on a well depth of 0.5 cm.

6.3 Related Bio-Rad Products

Power Supplies

165-5050 **PowerPac 300 Power Supply, 100/120 V**

165-5051 **PowerPac 300 Power Supply, 220/240 V**

Blotting Membranes

161-0153 **Zeta-Probe® Positively Charged Nylon Blotting Membrane,** sheets, 9 x 12 cm, 15

161-0154 **Zeta-Probe Positively Charged Nylon Blotting Membrane,** sheets, 10 x 15 cm, 15

161-0155 **Zeta-Probe Positively Charged Nylon Blotting Membrane,** sheets, 15 x 15 cm, 15

161-0156 **Zeta-Probe Positively Charged Nylon Blotting Membrane,** sheets, 15 x 20 cm, 15

161-0157 **Zeta-Probe Positively Charged Nylon Blotting Membrane,** sheets, 20 x 20 cm, 15

161-0158 **Zeta-Probe Positively Charged Nylon Blotting Membrane,** sheets, 20 x 25 cm, 3

161-0159 **Zeta-Probe Positively Charged Nylon Blotting Membrane,** roll, 30 cm x 3.3 m, 1

161-0165 **Zeta-Probe Positively Charged Nylon Blotting Membrane,** roll, 20 cm x 3.3 m, 1

161-0190 **Zeta-Probe GT (Genomic Tested) Positively Charged Nylon Blotting Membrane,** sheets, 9 x 12 cm, 15

161-0191 **Zeta-Probe GT (Genomic Tested) Positively Charged Nylon Blotting Membrane,** sheets, 10 x 15 cm, 15

- 161-0192 **Zeta-Probe GT (Genomic Tested) Positively Charged Nylon Blotting Membrane**, sheets, 15 x 15 cm, 15
- 161-0193 **Zeta-Probe GT (Genomic Tested) Positively Charged Nylon Blotting Membrane**, sheets, 15 x 20 cm, 15
- 161-0194 **Zeta-Probe GT (Genomic Tested) Positively Charged Nylon Blotting Membrane**, sheets, 20 x 20 cm, 15
- 161-0195 **Zeta-Probe GT (Genomic Tested) Positively Charged Nylon Blotting Membrane**, sheets, 20 x 25 cm, 3
- 161-0196 **Zeta-Probe GT (Genomic Tested) Positively Charged Nylon Blotting Membrane**, roll, 30 cm x 3.3 m, 1
- 161-0197 **Zeta-Probe GT (Genomic Tested) Positively Charged Nylon Blotting Membrane**, roll, 20 cm x 3.3 m, 1
- 161-0090 **Supported Nitrocellulose Membrane**, 0.45 micron, sheets, 7 x 8.4 cm, 10
- 161-0091 **Supported Nitrocellulose Membrane**, 0.45 micron, sheets, 10 x 15 cm, 10
- 161-0092 **Supported Nitrocellulose Membrane**, 0.45 micron, sheets, 15 x 15 cm, 10
- 161-0093 **Supported Nitrocellulose Membrane**, 0.45 micron, sheets, 20 x 20 cm, 10
- 161-0094 **Supported Nitrocellulose Membrane**, 0.45 micron, roll, 30 cm x 3 m, 1
- 161-0095 **Supported Nitrocellulose Membrane**, 0.20 micron, sheets, 7 x 8.4 cm, 10
- 161-0096 **Supported Nitrocellulose Membrane**, 0.20 micron, sheets, 15 x 15 cm, 10
- 161-0097 **Supported Nitrocellulose Membrane**, 0.20 micron, roll, 30 cm x 3 m, 1

Vacuum Blotting Apparatus

- 165-5000 **Model 785 Vacuum Blotter**
- 165-5001 **Model 785 Vacuum Blotter System**, 120 VAC
- 165-5002 **Model 785 Vacuum Blotter System**, 220/240 VAC

Semi-Dry Transfer Cells

- 170-3940 **Trans-Blot® SD Semi-Dry Electrophoresis Transfer Cell**
- 170-3948 **Trans-Blot SD System**, 100/120 VAC
- 170-3949 **Trans-Blot SD System**, 220/240 VAC

UV Crosslinking Chamber

- 165-5031 **GS Gene Linker® UV Chamber**, 120 VAC
- 165-5032 **GS Gene Linker UV Chamber**, 220 VAC
- 165-5033 **GS Gene Linker UV Chamber**, 240 VAC
- 165-5034 **GS Gene Linker UV Chamber**, 100 VAC

Gel Reagents and Standards

162-0019	Low Melt Preparative Grade Agarose , 100 g
162-0133	Molecular Biology Certified Agarose , 500 g
162-0126	High Strength Analytical Grade Agarose , 500 g
170-8200	AmpliSize DNA Size Standard , 50-2,000 bp
170-8210	DNA Size Standard , 1-4.2 Kb ladder
170-8220	DNA Size Standard , 0.7-8.4 Kb
170-3470	DNA Size Standard , λ -Hind III
170-3465	DNA Size Standard , pBR322 AVa II/Eco RI
161-0404	Bromophenol Blue , 10 g
161-0423	Xylene Cyanole FF , 25 g
161-0433	Ethidium Bromide Solution , 10 ml, 10 mg/ml

Electrophoresis Buffers

161-0733	10x Tris/Boric Acid/EDTA (TBE) , 1 l
161-0743	50x Tris/Acetic Acid/EDTA (TAE) , 1 l
161-0719	Tris , 1 kg
161-0751	Boric Acid , 1 kg
161-0729	EDTA , 500 g

DNA Gel Image Analysis and Documentation Systems

170-3742	Standard Polaroid® Documentation System , 120 VAC
170-3746	Standard Polaroid Documentation System , 100 VAC
170-3747	Standard Polaroid Documentation System , 220/240 VAC
170-7520	Gel Doc™ 1000 UV Gel Documentation System-PC , 100 VAC
170-7521	Gel Doc 1000 UV Gel Documentation System-PC , 120 VAC
170-7522	Gel Doc 1000 UV Gel Documentation System-PC , 220/240 VAC
170-7525	Gel Doc 1000 UV Gel Documentation System-Mac , 100 VAC
170-7526	Gel Doc 1000 UV Gel Documentation System-Mac , 120 VAC
170-7527	Gel Doc 1000 UV Gel Documentation System-Mac , 220/240 VAC

Section 7

References

1. Sambrook, Fritsch, and Maniatis, **Molecular Cloning, A Laboratory Manual**, Second Edition, Cold Spring Harbor Laboratory Press, 1989.
2. **Current Protocols in Molecular Biology**, Greene Publishing Associates and Wiley-Interscience, 1989.

Additional Reading

3. Kopchick, J. J., Cullen, B. R. and Stacey, D. W., *Anal. Biochem.*, **115**, 419 (1981).
4. Southern, E., *Methods in Enzymol.*, **68**, 152 (1979).
5. The Bio-Rad Silver Stain - Bulletin 1089, Bio-Rad Laboratories, Hercules, CA.
6. Bittner, M., Kupferer, P. and Morris, C. F., *Anal. Biochem.*, **102**, 459 (1980).
7. Bio-Rad Trans-Blot Cell Operation Instructions, Bulletin 1082, Bio-Rad Laboratories, Hercules, CA.
8. Winberg, G. and Hammarskjold, M. L., *Nucleic Acids Res.*, **8**, 253 (1980).
9. Jytatekadze, T. V., Axelrod, V. D., Gorbulev, V. G., Belzhelarskaya, S. N. and Vartikyan, R. M., *Anal. Biochem.*, **100**, 129 (1979).
10. Dretzen, G., Bellard, M., Sassone-Corsi, P. and Chambon, P., *Anal. Biochem.*, **112**, 295 (1981).

* The Polymerase Chain Reaction (PCR) process is covered by patents owned by Hoffmann-LaRoche. Use of the PCR process requires a license.

** IEC 1010-1 is an internationally accepted electrical safety standard for laboratory instruments.



**Bio-Rad
Laboratories**

**Life Science
Group**

2000 Alfred Nobel Drive
Hercules, California 94547
Telephone (510) 741-1000
Fax: (510) 741-5800

Australia, Bio-Rad Laboratories Pty Limited, Block Y Unit 1, Regents Park Industrial Estate, 391 Park Road, Regents Park, NSW 2143 • Phone 02-9414-2800 • Fax 02-9914-2888
Austria, Bio-Rad Laboratories Ges.m.b.H., Auhofstrasse 78D, 1130 Wien • Phone (1) 877 89 01 • Fax (1) 876 56 29
Belgium, Bio-Rad Laboratories S.A./N.V., Begoniastraat 5, 9810 Nazareth Eke • Phone 09-385 55 11 • Fax 09-385 65 54
Canada, Bio-Rad Laboratories (Canada) Ltd., 5671 McAdam Road, Mississauga, Ontario L4Z 1N9 • Phone (905) 712-2771 • Fax (905) 712-2990
China, Bio-Rad Laboratories, 14, Zhi Chun Road, Hai Dian District, Beijing 100088 • Phone (01) 2046622 • Fax (01) 2051876
Denmark, Bio-Rad Laboratories, Symbion Science Park, Fruebjergvej 3, DK-2100 Copenhagen • Phone 39 17 9947 • Fax 39 27 1698
Finland, Bio-Rad Laboratories, Business Center Länsikeskus, Pihatörmä 1A SF-02240, Espoo, • Phone 90 804 2200 • Fax 90 804 1100
France, Bio-Rad S.A., 94/96 rue Victor Hugo, B.P. 220, 94 203 Ivry Sur Seine Cedex • Phone (1) 49 60 68 34 • Fax (1) 46 71 24 67
Germany, Bio-Rad Laboratories GmbH, Heidemannstraße 164, D-80939 München/Postfach 450133, D-80901 München • Phone 089 31884-0 • Fax 089 31884-100
India, Bio-Rad Laboratories, C-248 Defence Colony, New Delhi 110 024 • Phone 91-11-461-0103 • Fax 91-11-461-0765
Italy, Bio-Rad Laboratories S.r.l., Via Cellini, 18/A, 20090 Segrate Milano • Phone 02-21609 1 • Fax 02-21609-399
Japan, Nippon Bio-Rad Laboratories, 7-18, Higashi-Nippori 5-Chome, Arakawa-ku, Tokyo 116 • Phone 03-5811-6270 • Fax 03-5811-6272
The Netherlands, Bio-Rad Laboratories B. V., Fokkerstraat 10, 3905 KV Veenendaal • Phone 0318-540666 • Fax 0318-542216
New Zealand, Bio-Rad Laboratories Pty Ltd., P. O. Box 100-051, North Shore Mail Centre, Auckland 10 • Phone 09-443 3099 • Fax 09-443 3097
Pacific, Bio-Rad Laboratories, Unit 1111, 11/F., New Kowloon Plaza, 38, Tai Kok Tsui Road, Tai Kok Tsui, Kowloon, Hong Kong • Phone 7893300 • Fax 7891257
Singapore, Bio-Rad Laboratories (Singapore) Ltd., 221 Henderson Rd #05-19, Henderson Building, Singapore 0315 • Phone (65) 272-9877 • Fax (65) 273-4835
Spain, Bio-Rad Laboratories, S. A. Avda Valdelaparra 3, Pol. Ind. Alcobendas, E-28100 Alcobendas, Madrid • Phone (91) 661 70 85 • Fax (91) 661 96 98
Sweden, Bio-Rad Laboratories AB, Gärdsvägen 7D, Box 1276, S-171 24 Solna • Phone 46-(0)8-735 83 00 • Fax 46-(0)8-735 54 60
Switzerland, Bio-Rad Laboratories AG, Kanalstrasse 17, Postfach, CH-8152 Glattbrugg • Phone 01-809 55 55 • Fax 01-809 55 00
United Kingdom, Bio-Rad Laboratories Ltd., Bio-Rad House, Maylands Avenue, Hemel Hempstead, Herts HP2 7TD • Free Phone 0800 181134 • Fax 01442 259118