

HS35

Technical Specification

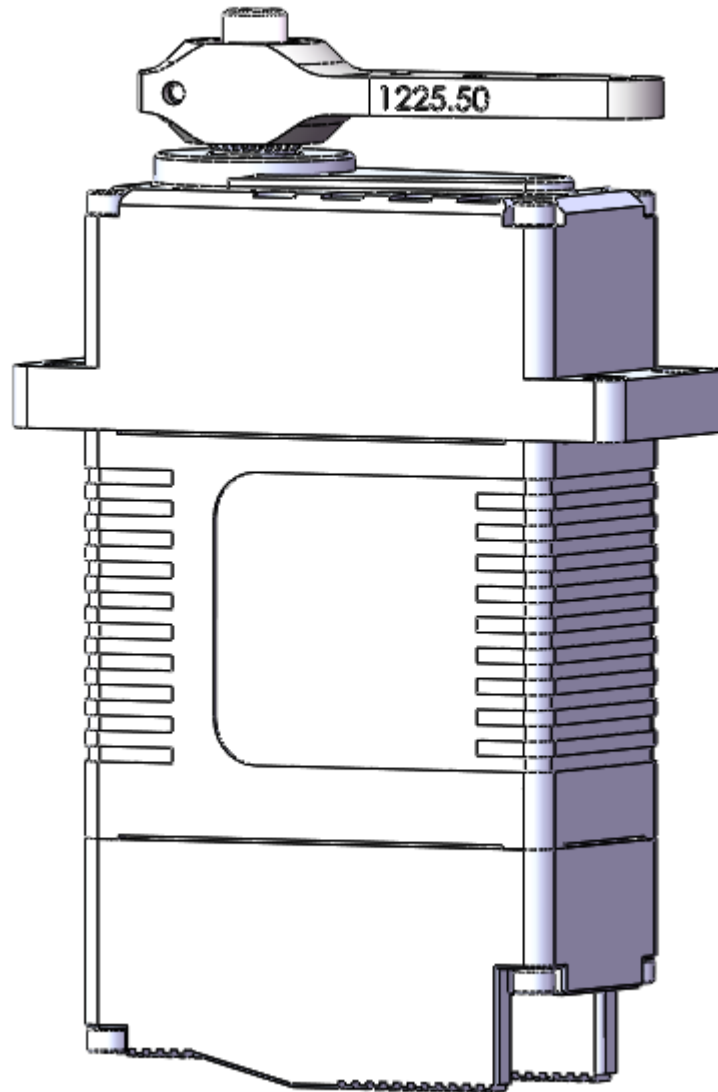

HS35-30-M-6055-1

HS35-30-M-6055-2

1. Installation Dimensions

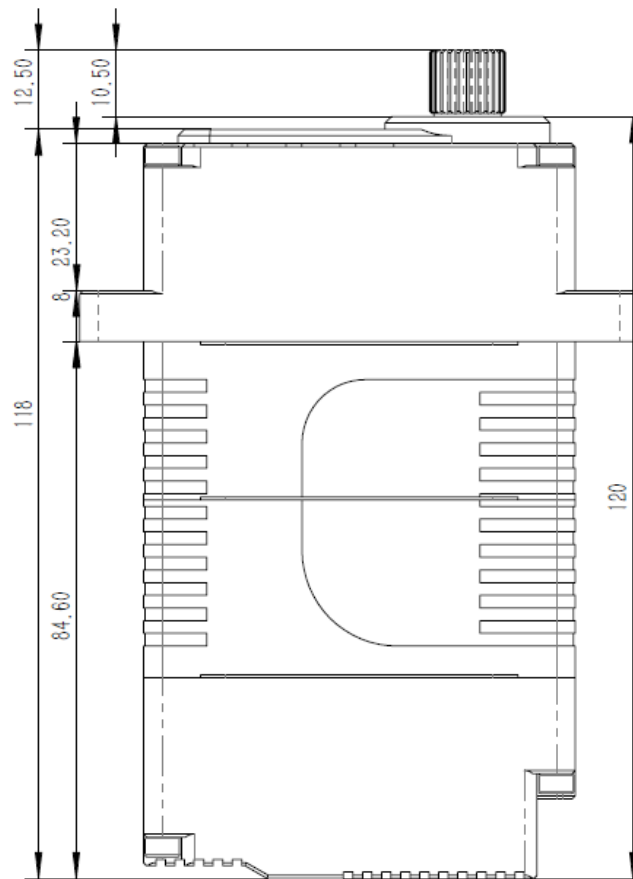
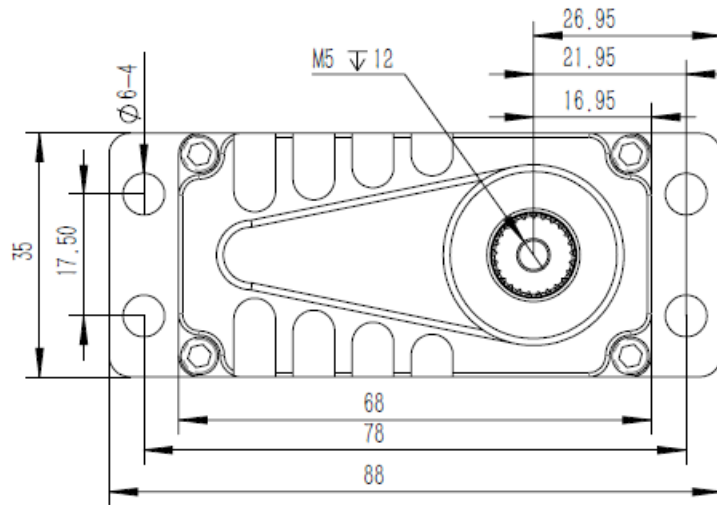

Case Dimensions	68mm*35mm*120mm
Weight	660g

2. Operating Data

Rated Voltage	DC30V
Voltage Range	DC24V-30V
Stall Torque	30N.m@30V
Rated Torque	12N.m@30V
Stall Current	5.00A
Rated Current	1.95A
No-load Speed	220°/s @25°C
Rated Speed	150°/s @25°C
Default Travel Angle	±50° = 100° total travel
Max. Standard Travel Angle	±100° = 200° total travel
Extended Travel Angle (optional)	±165° = 330° total travel
Operating Temperature Range	-30°C.....+65°C
Backlash (mechanical)	≅ 0.5°

3. Performance

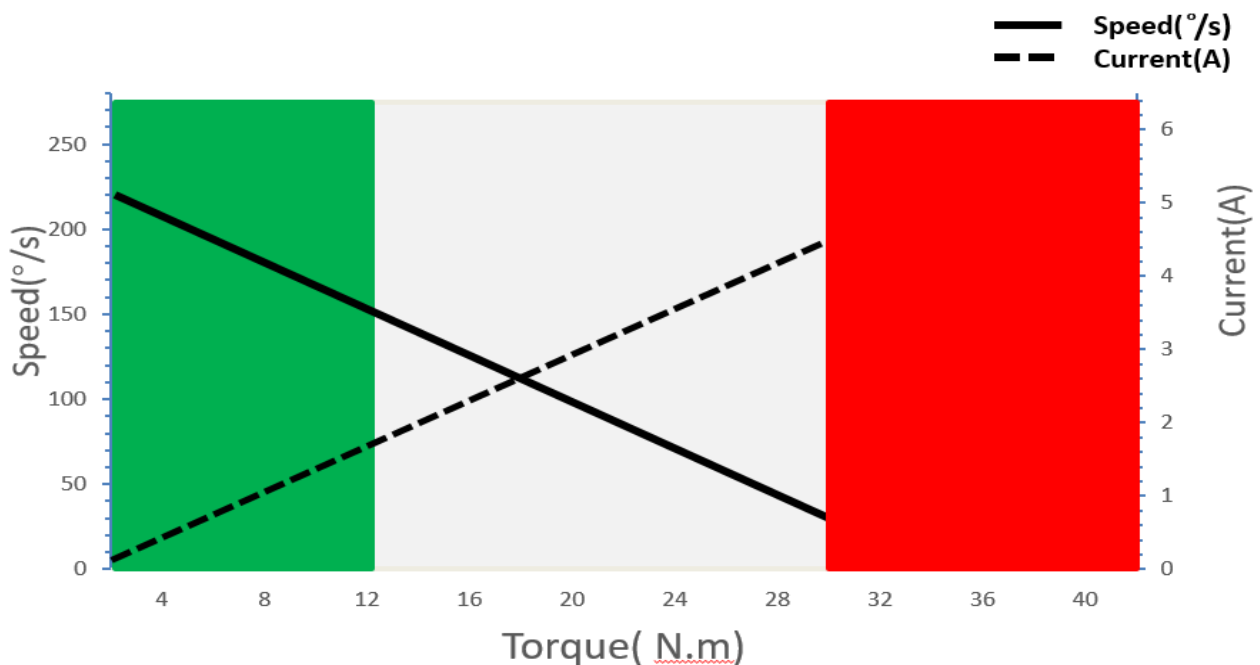

Operation Model:

■ Continuous
 ■ Short Time<10s Repeat
 ■ <1s,60s Cool

4. Command Signal

4.1 PWM Command Interface

Signal Voltage	TTL-Level: HIGH:min.3.3V,max.5.0V TTL-Level: Low:min.0.0V,max.1.5V
Pulse Lengths	500us-2500us
Pulse Lengths for Position-50°/0°/+50°	1000us/1500us/2000us

4.2 RS 485 Command Interface

Baud-Rate	115200 ±1.5% bits/s
Protocol (Documentation available)	10 Byte (incl. 1 byte Check Sum)

4.3 RS 485 Protocol Specifications

Number of Data Bits	8
Number of Stop Bits	1
Parity	None

Command / Response Frame

Byte #	Description	Byte #	Description
1	Frame Head(0xFE)	6	Data
2	Version(0xCA)	7	Data
3	Address	8	Data
4	Command code	9	Check Sum
5	Data	10	Frame End

4.4. Position Feedback Value (RS 485 Versions)

Integrated in the RS 485 protocol a Position Feedback Value is available, representing the output shaft's angular position. Value readout by sending a request command. Detailed information is provided in the RS 485 documentation.

5. Materials and Features

Case Material	Aluminum Alloy 7075
Waterproof Resistance	IP 67, waterproof to 1m depth
Motor Type	Brushless DC Motor
Gear Set Material	Hardened Steel
Position Sensor	Contactless
Shielded Connecting Cable	Optional
RS 485 Communication Interface	Optional

6. Output Shaft Spline

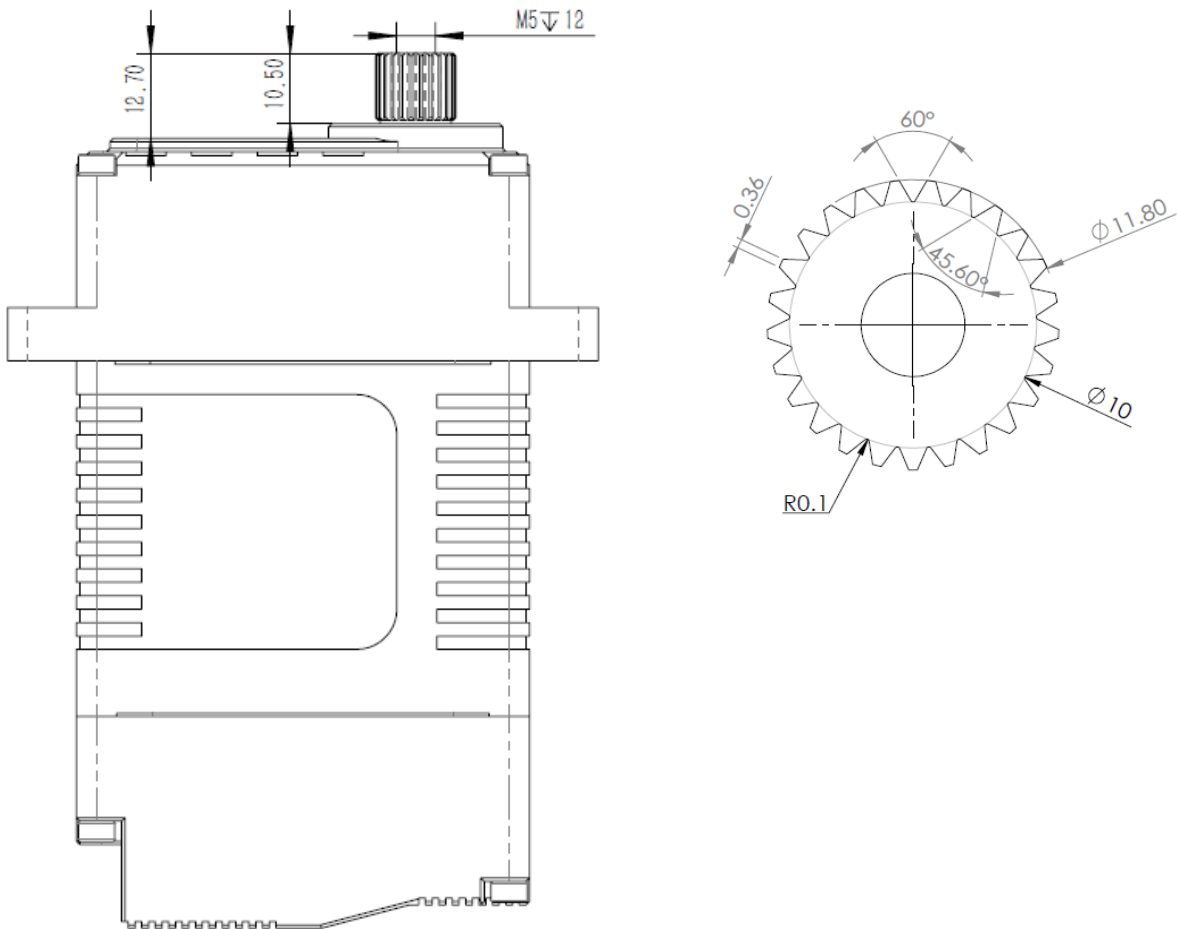

7. Electrical Connection Options

Industrial Standard J30J-15ZKP electrical Connector

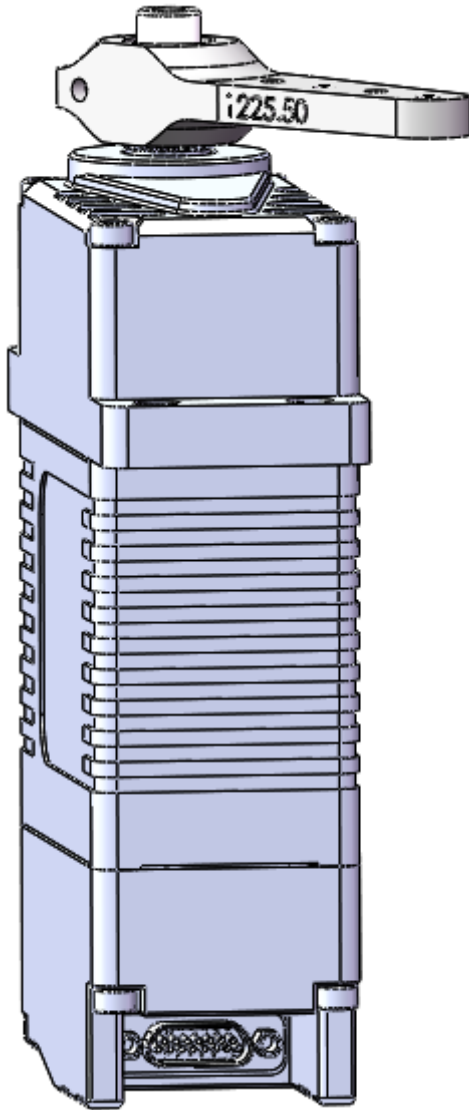

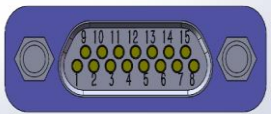
		Standard Connector	
		Type	J30J-15ZKP
		Mating	J30J-15TJL
			
1	}	DC + (Supply Voltage)	
2			
3			
4			
5	}	GND (Supply Ground)	
6			
7			
8			
9		NC (Do not connect)	
10		PWM (Command Signal)	
11			
12		RX+(DC4.5V-8.4V)	
13			
14		RX-	
15			

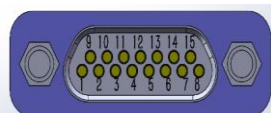
		Standard Connector	
		Type	J30J-15ZKP
		Mating	J30J-15TJL
			
Pin Assignment (RS485)			
1	}	DC +(Supply Voltage)	
2			
3			
4			
5	}	GND(Supply Ground)	
6			
7			
8			
9		NC (Do not connect)	
10			
11			
12		RS485A	
13			
14		RS485B	
15			

8. Accessories (Optionals)

Item	Item-No.
Aluminum Servo Arm (Single side)	1225.50
Aluminum Servo Arm (Double side)	1225.55
Aluminum Servo Disc	1225.16.5

Item# 1225.50

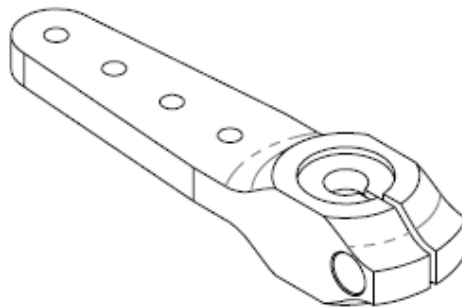
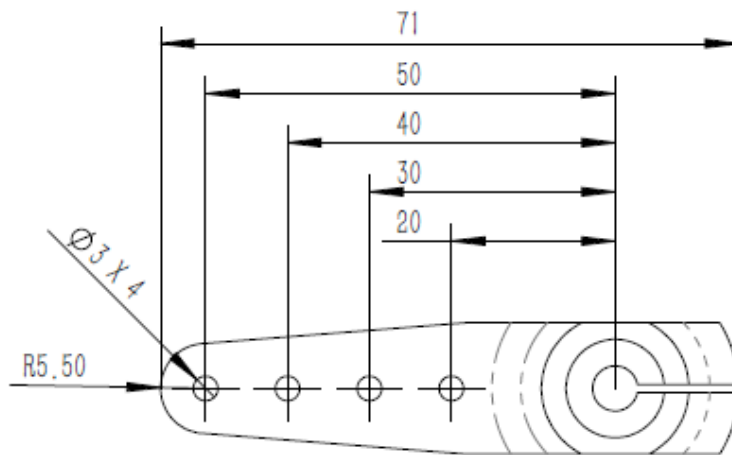
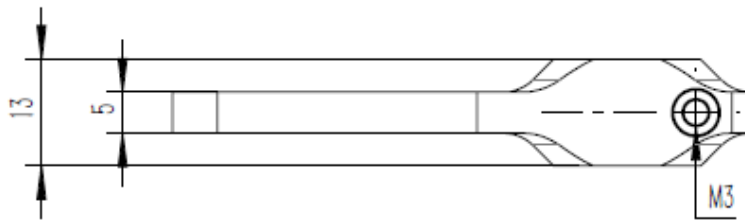

Item# 1225.55

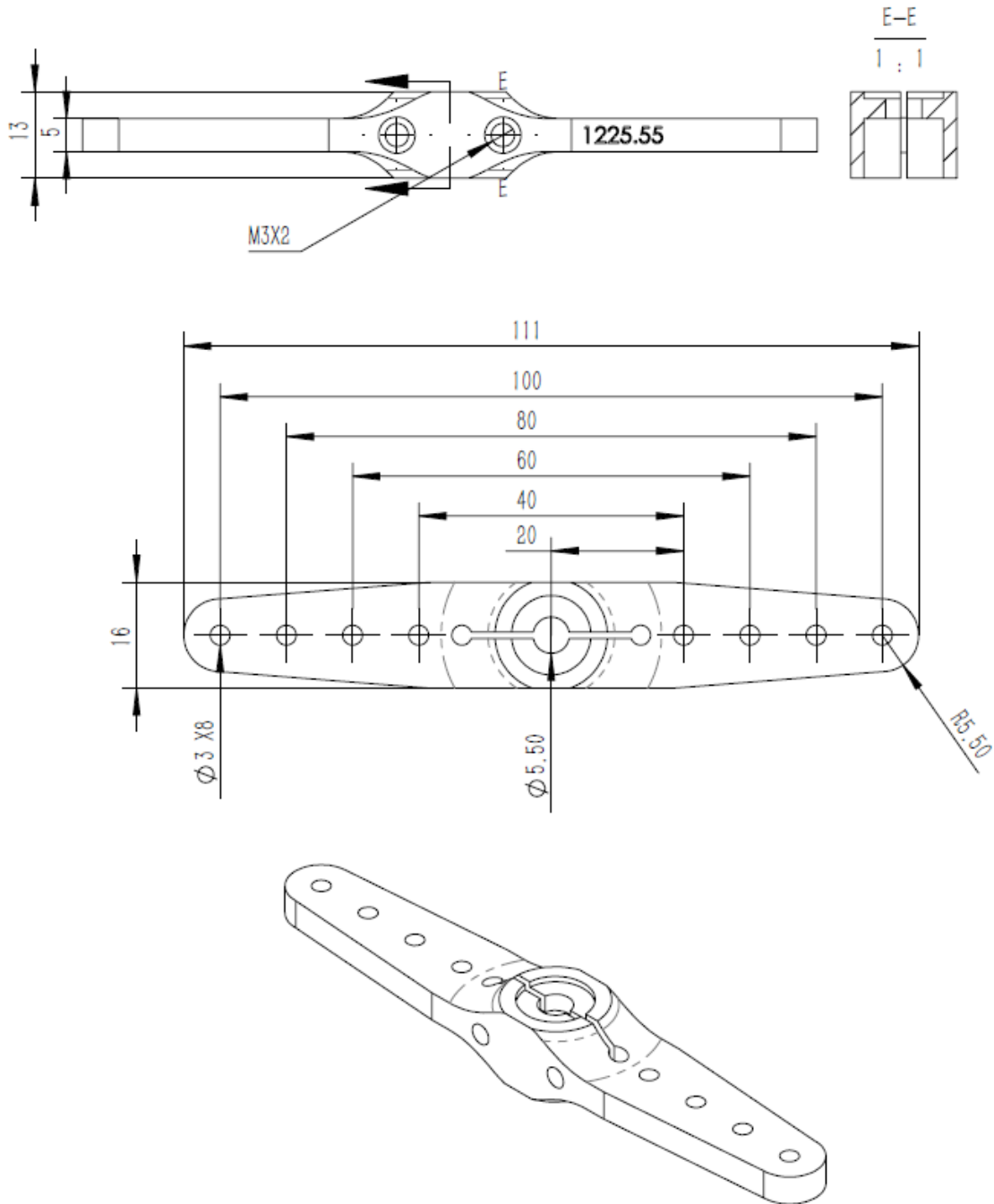

Item# 1225.16.5

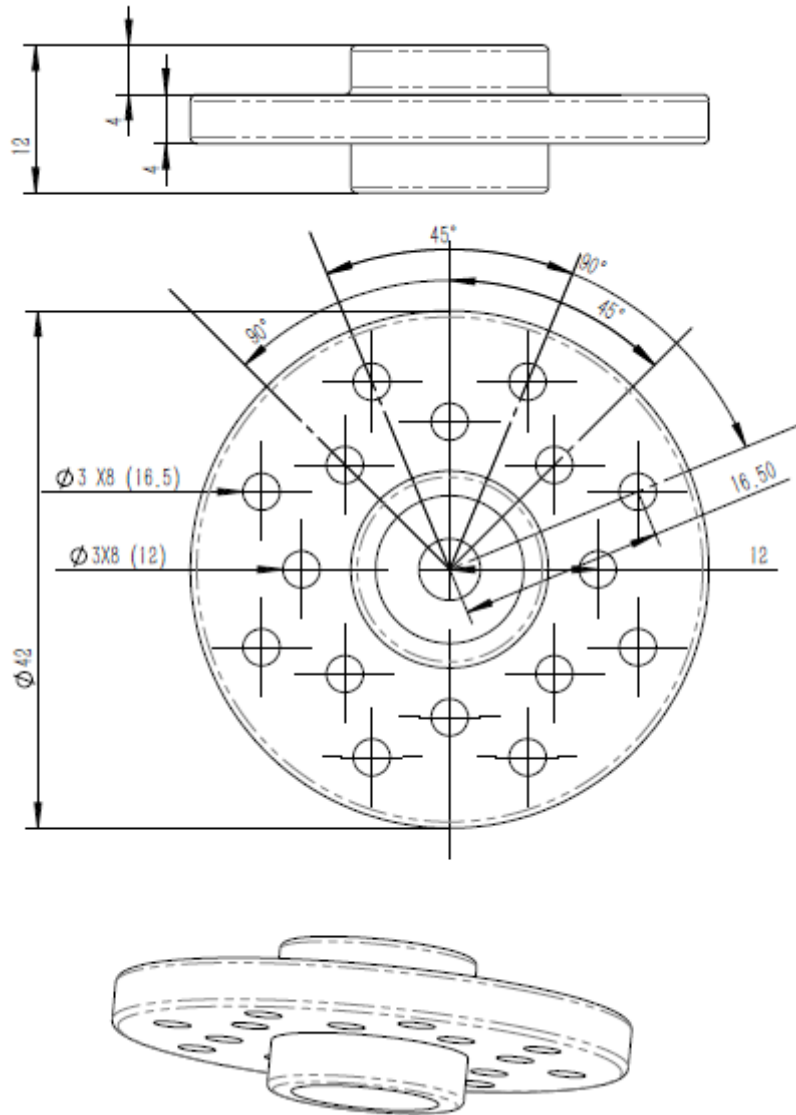

09. Item Number System

