

A20-4515

Technical Specification

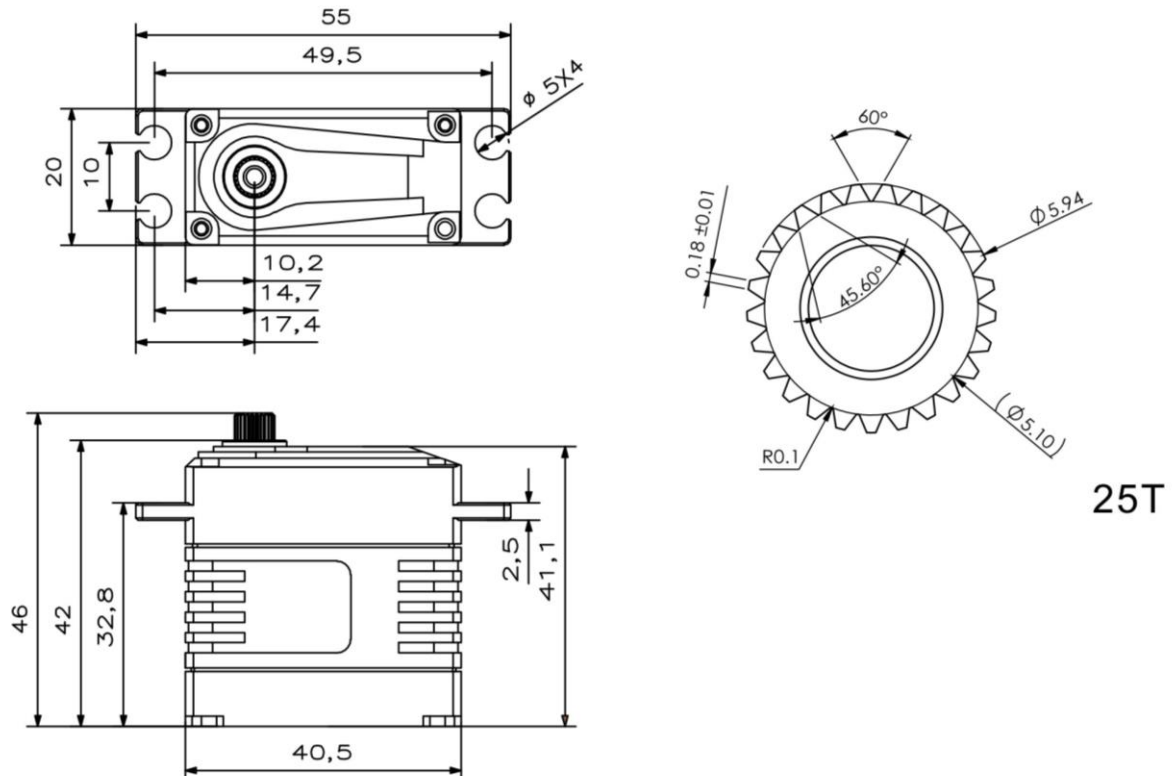

Operating Data

	A20-4515
Operation Voltage(rated)	DC7.4V
Operation Voltage Range	DC6.0V-8.4V
Torque	36Kg.cm@6.0V
	45Kg.cm@7.4V
	50Kg.cm@8.4V
Speed	0.19sec/60 °@6.0V
	0.15sec /60 °@7.4V
	0.13sec /60 °@8.4V
Travel Angle	±50° when 1000-2000us
Operating Temperature Range	-20°C ·····+65°C

Performance

A20-4515 @ 7.4V

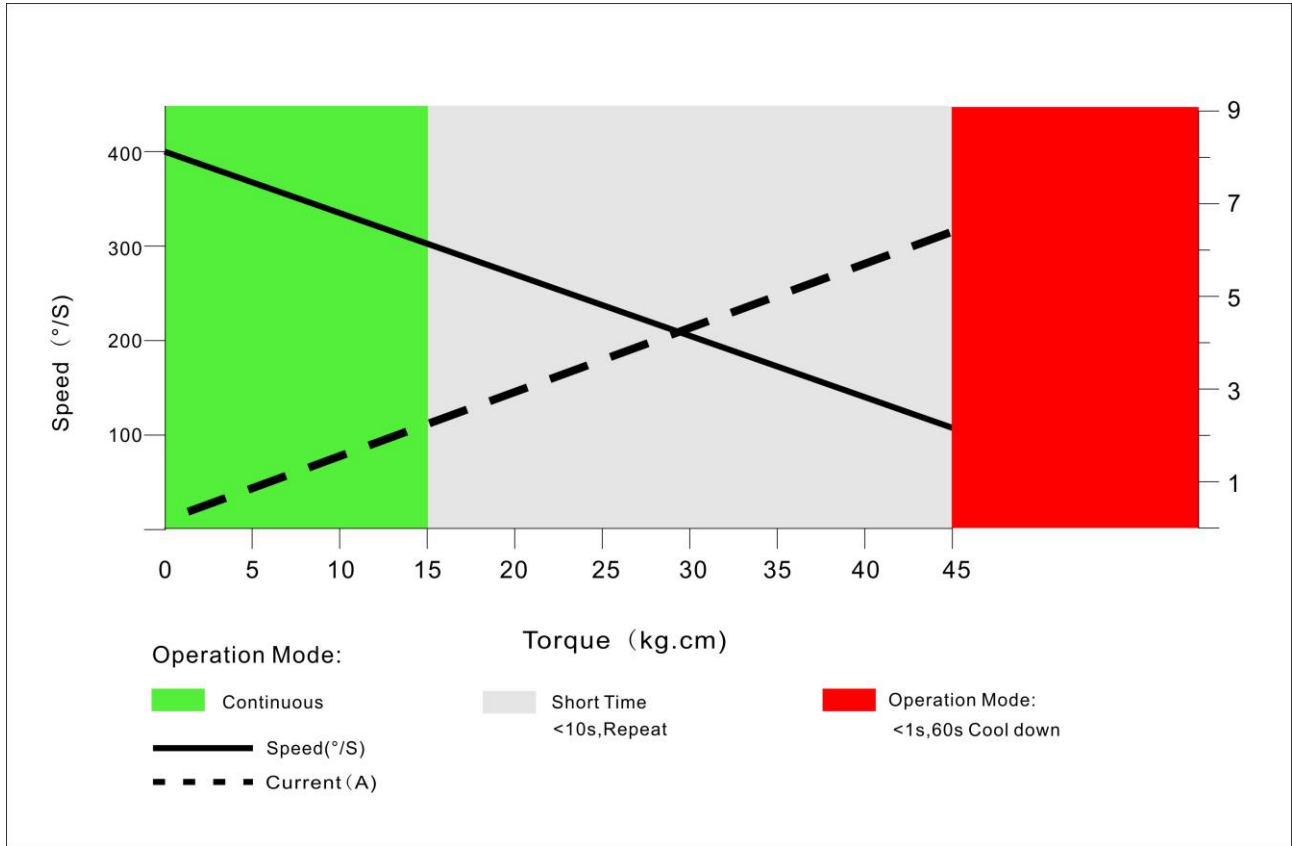

PWM Command Signal

PWM	A20-4515
Signal Voltage	TTL-Level: HIGH:min.3.3V,max.5.0V TTL-Level: Low:min.0.0V,max.1.5V
Pulse Lengths	900-2100us
Pulse Lengths for Position -50° /center/ $+50^{\circ}$	1000us/1500us/2000us
Resolution	<2us

Materials and protective features

Case Material	Aluminum Alloy
Motor Type	Brushless
Gear Set Material	Hardened Steel
Position Sensor	Potentionmeter
Position Feedback	Optional
Shielded Connecting Cable	22AWG

Dimensions

Case Dimensions	40.5*20*42mm
Weight	80g