

A15-1810

Technical Specification

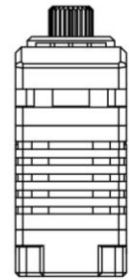
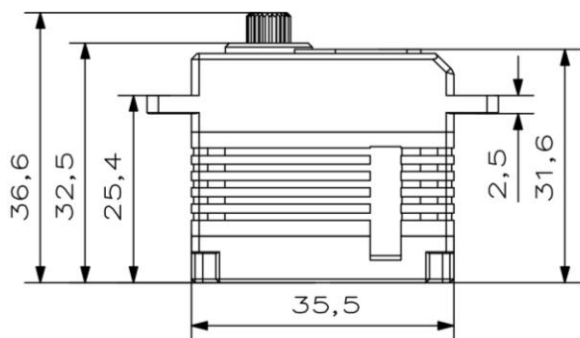
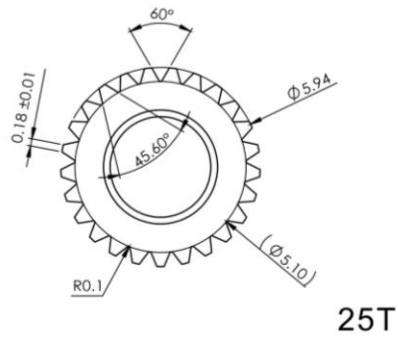
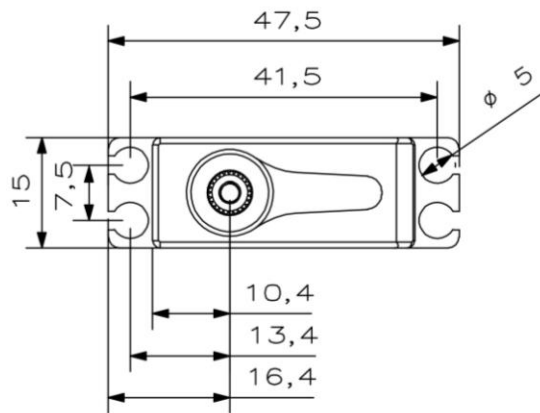

Operating Data

	A15-1810
Operation Voltage(rated)	DC7.4V
Operation Voltage Range	DC6.0V-8.4V
Torque	15Kg.cm@6.0V
	18Kg.cm@7.4V
	20Kg.cm@8.4V
Speed	0.14sec/60 °@6.0V
	0.12sec/60 °@7.4V
	0.10sec/60 °@8.4V
Travel Angle	± 50° when 1000-2000us
Operating Temperature Range	-10°C……+55°C

Performance

A15-1810

@7.4V

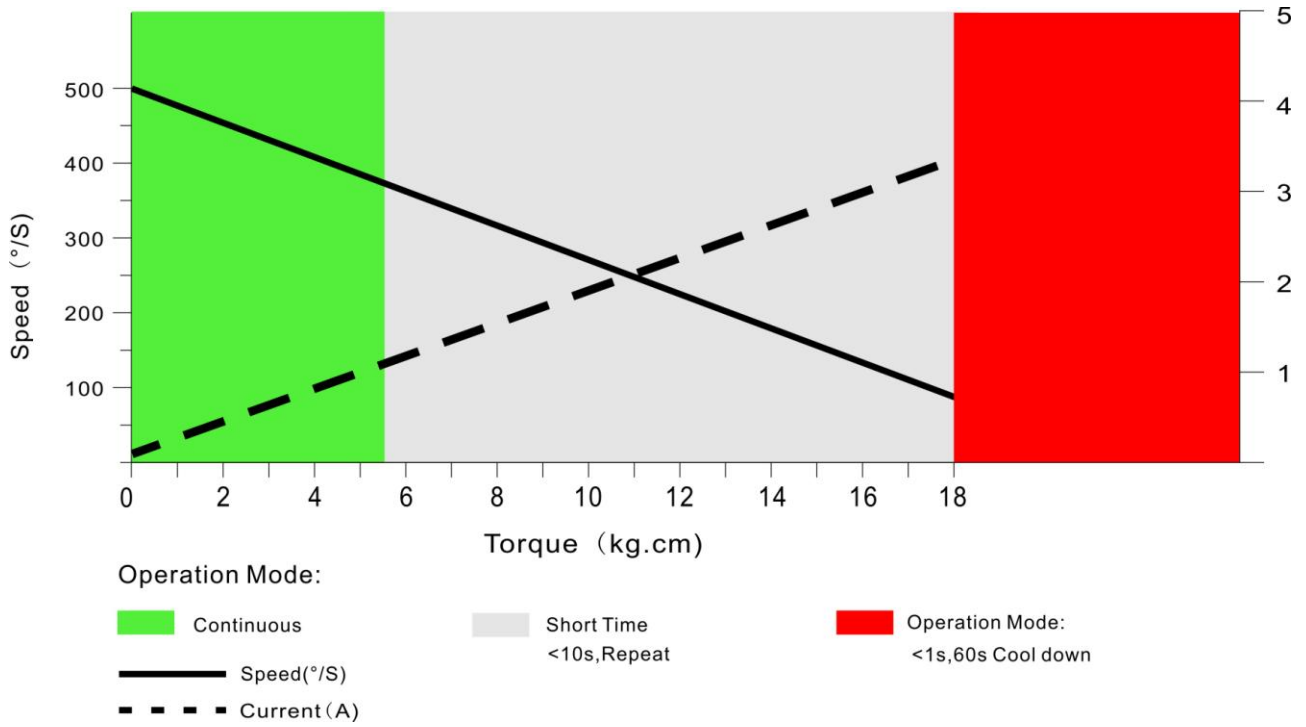

PWM Command Signal

PWM	A15-1810
Signal Voltage	TTL-Level: HIGH:min.3.3V,max.5.0V TTL-Level: Low:min.0.0V,max.1.5V
Pulse Lengths	900-2100us
Pulse Lengths for Position -50° /center/ $+50^{\circ}$	1000us/1500us/2000us
Resolution	<2us

Materials and protective features

Case Material	Aluminum Alloy
Motor Type	Coreless
Gear Set Material	Phosphor Bronze +Hardened Steel
Position Sensor	Potentionmeter
Position Feedback	Optional
Shielded Connecting Cable	26AWG

Dimensions

Case Dimensions	35.5*15*32.5mm
Weight	42g