

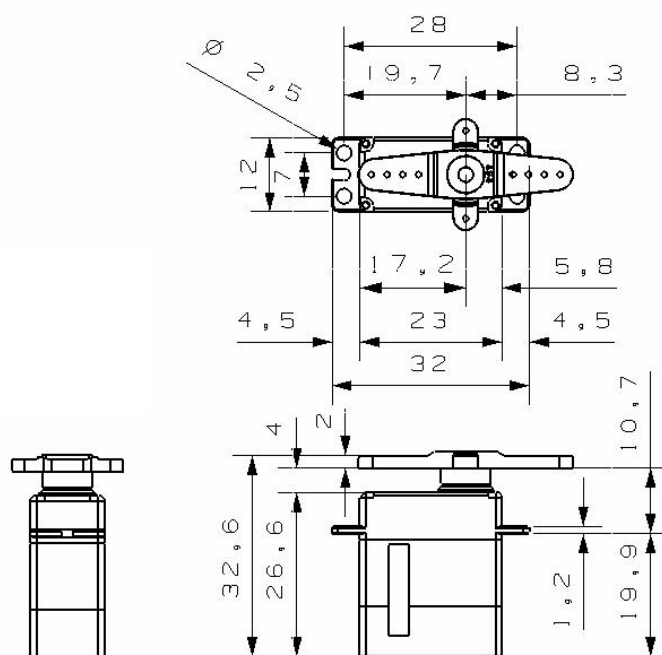

MS320

Technical Specification





Operating Data

	MS320
Operation Voltage(rated)	DC7.4V
Operation Voltage Range	DC4.8V-8.4V
Torque	4.50Kg.cm@6.0V
	5.50Kg.cm@7.4V
Speed	0.09sec/60 °@6.0V
	0.08sec/60 °@7.4V
Travel Angle	± 100° when 500-2500us ± 50° when 1000-2000us
Operating Temperature Range	-10°C·····+65°C



Performance

MS320

@6V

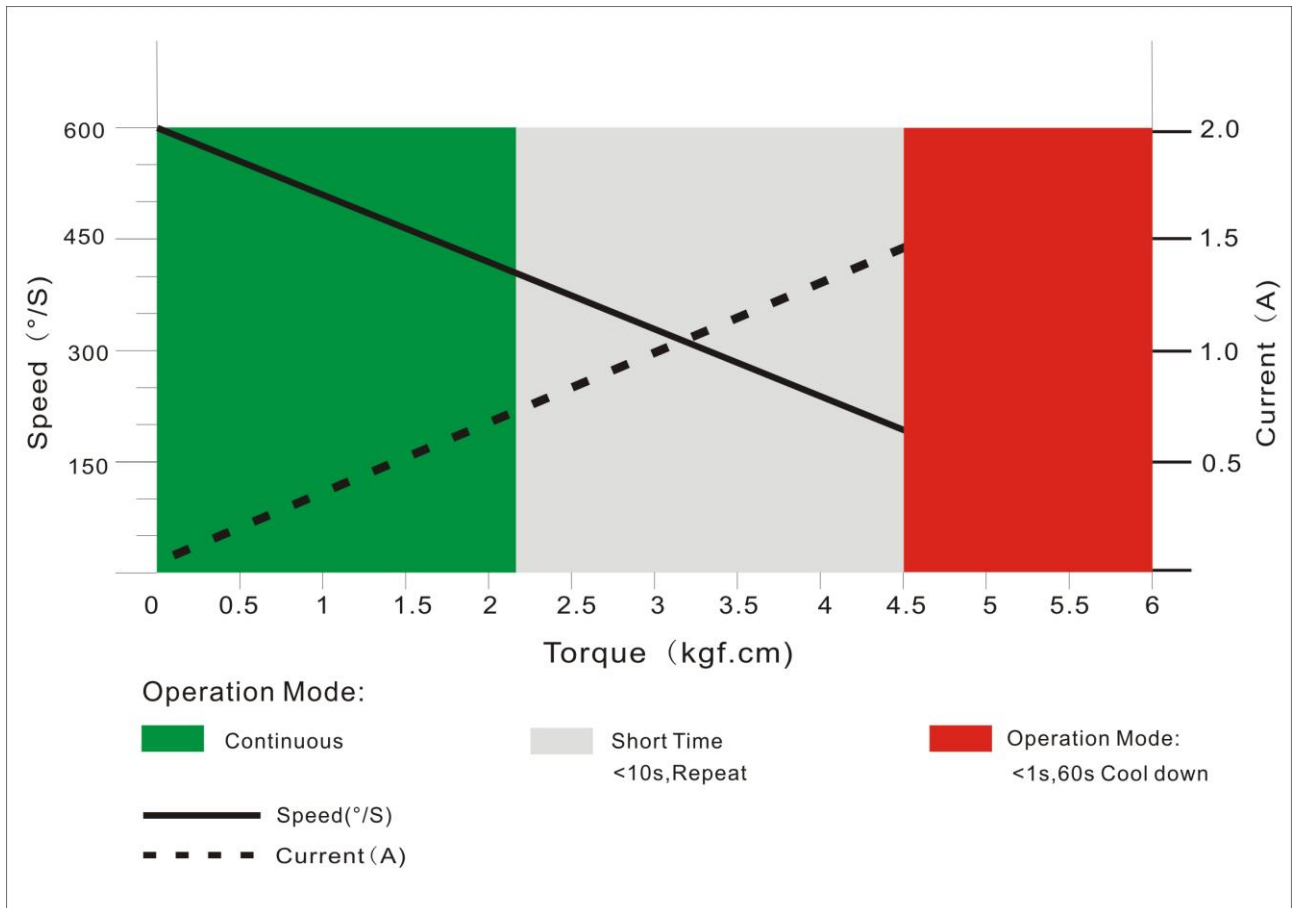



PWM Command Signal

PWM	MS320
Signal Voltage	TTL-Level: HIGH:min.3.3V,max.5.0V TTL-Level: Low:min.0.0V,max.1.5V
Pulse Lengths	500-2500us
Pulse Lengths for Position -100° /center/+100°	500us/1500us/2500us
Resolution	<2us

Materials and protective features

Case Material	Aluminum Alloy
Splash Surface Treatment	
Salt Water Resistance	
EMI/RFI Shielding	
Motor Type	Coreless
Gear Set Material	Hardened Steel
Position Sensor	Contactless
Position Feedback	Optional
Shielded Connecting Cable	26AWG

Dimensions

Case Dimensions	23*12*27.5mm
Weight	21g