

# X50-28-350

## Technical Specification

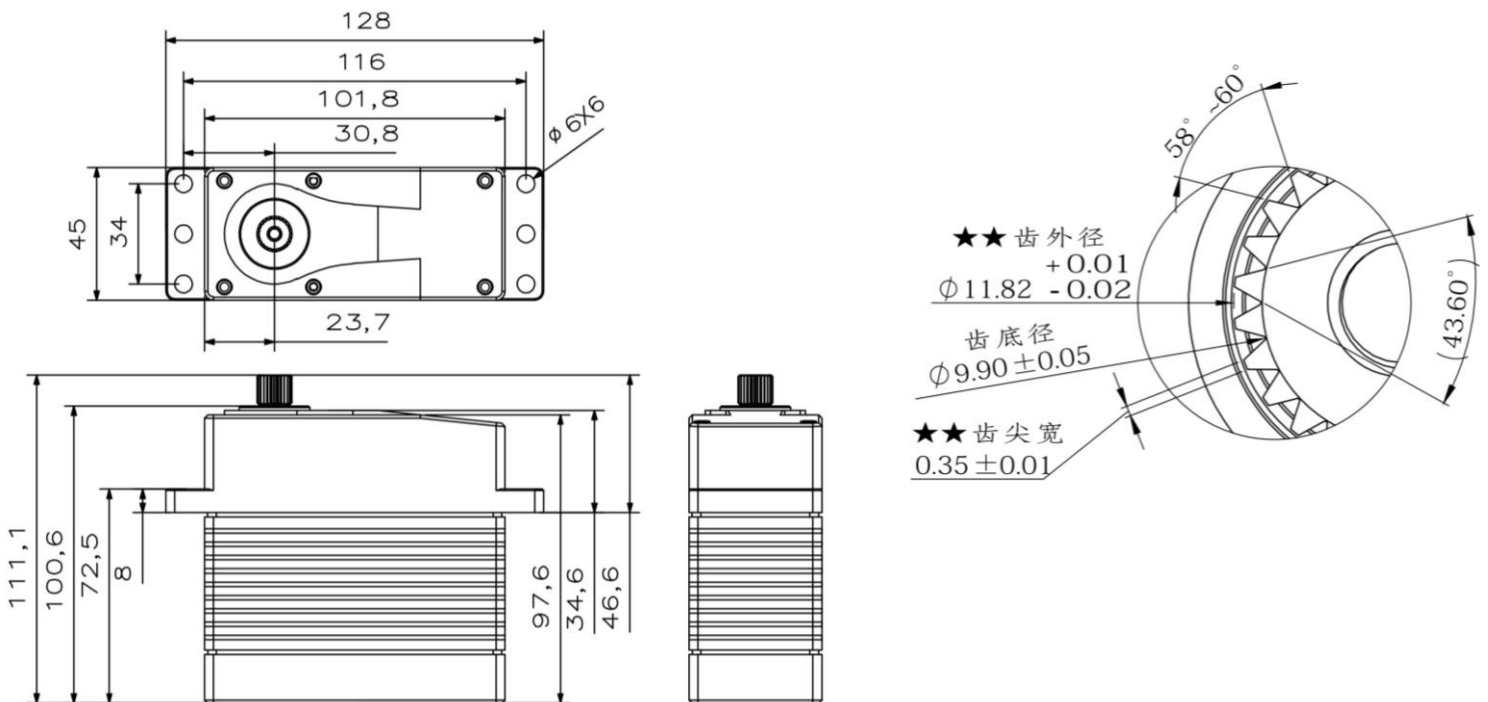

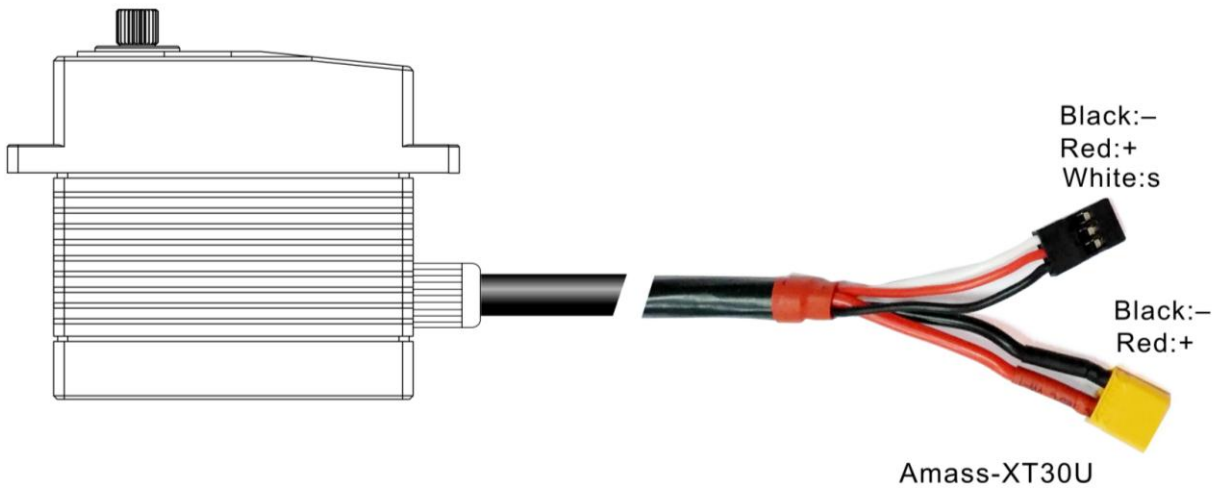

## Operating Data

	<b>X50-28-350</b>
<b>Operation Voltage(rated)</b>	DC28V
<b>Operation Voltage Range</b>	DC24V-32V
<b>Torque</b>	350Kg.cm@28V
<b>Speed</b>	0.22sec/60 °@28V
<b>Travel Angle</b>	± 50° when 1000-2000us
<b>Operating Temperature Range</b>	-10°C .....+55°C
	-40°C .....+65°C (optional)

## Performance

@28V

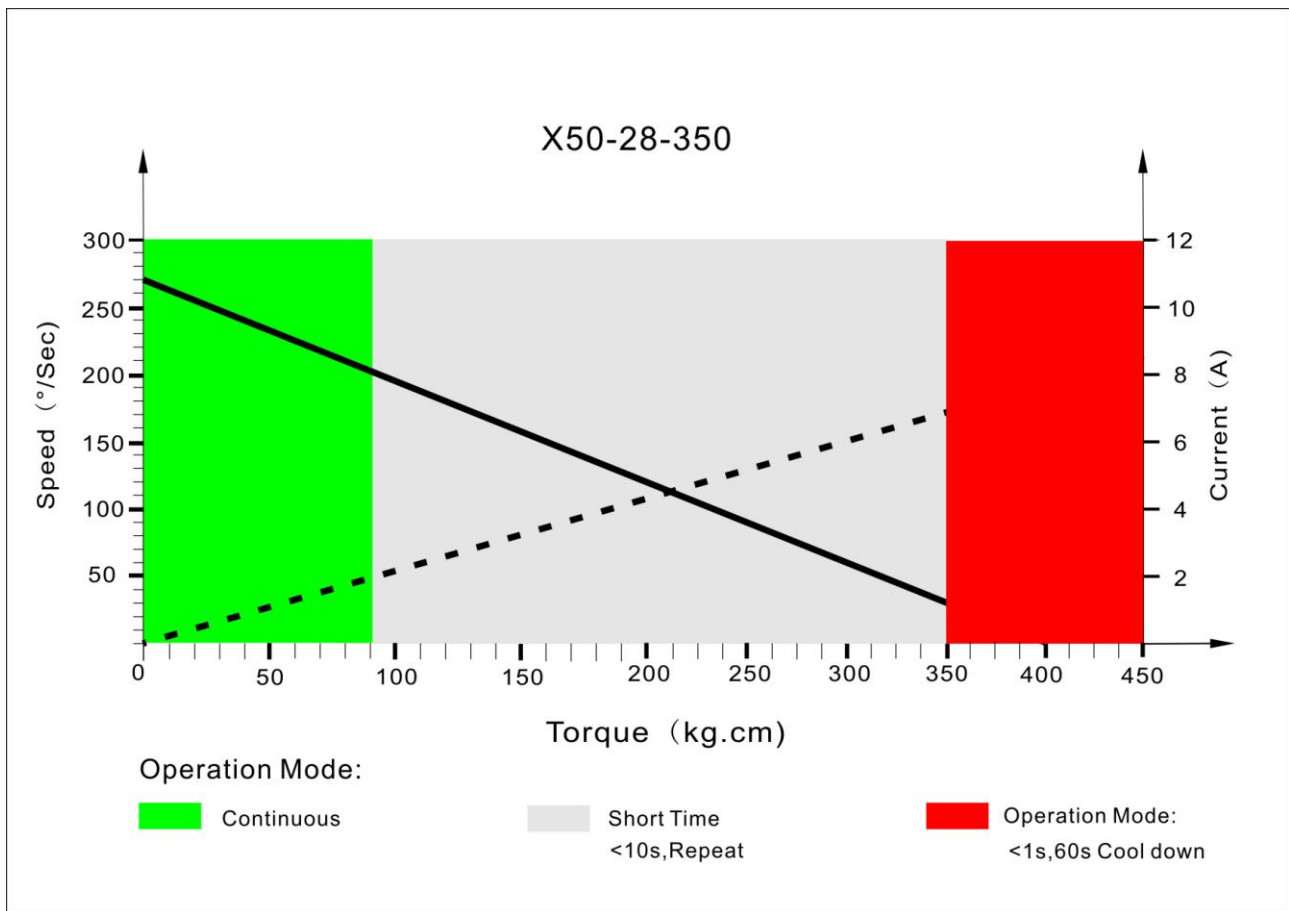

**PWM Command Signal**

<b>PWM</b>	<b>X50-28-350</b>
<b>Signal Voltage</b>	TTL-Level: HIGH:min.3.3V,max.5.0V TTL-Level: Low:min.0.0V,max.0.5V
Pulse Lengths	900-2100us
Pulse Lengths for Position $-50^{\circ}$ /center/ $+50^{\circ}$	1000us/1500us/2000us
Resolution	2us

**Materials and protective features**

Case Material	Aluminum Alloy 7075
Splash Surface Treatment	
Salt Water Resistance	IP67
EMI/RFI Shielding	
Motor Type	Brushless
Gear Set Material	Titanium/Hardened Steel
Position Sensor	Potentionmeter
Position Feedback	Optional
Shielded Connecting Cable	

**Dimensions**

Case Dimensions	101.80*45*100.6mm
Weight	826g

## Aluminum Horn 25T-12-60

