

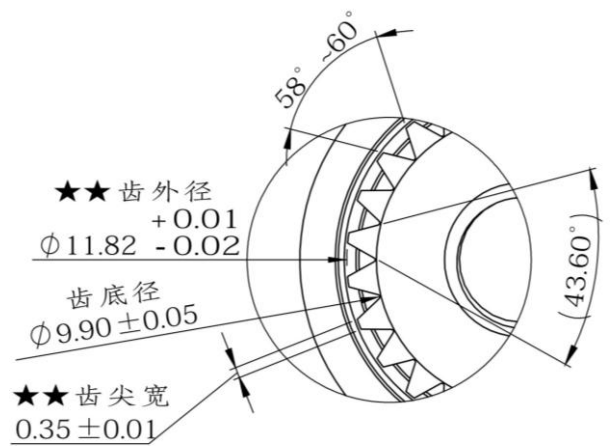

# X30-12-150

## Technical Specification

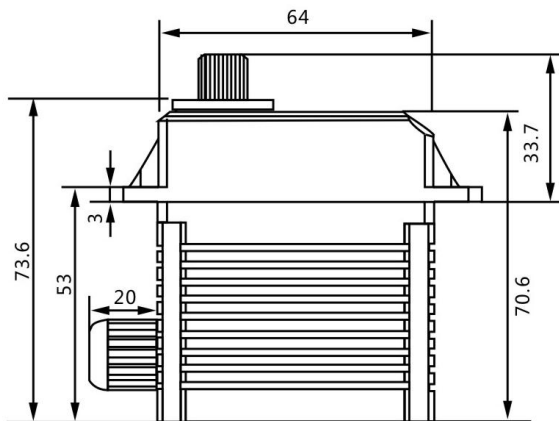

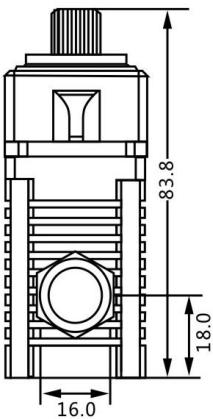
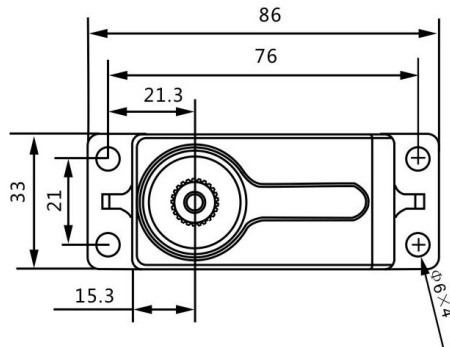
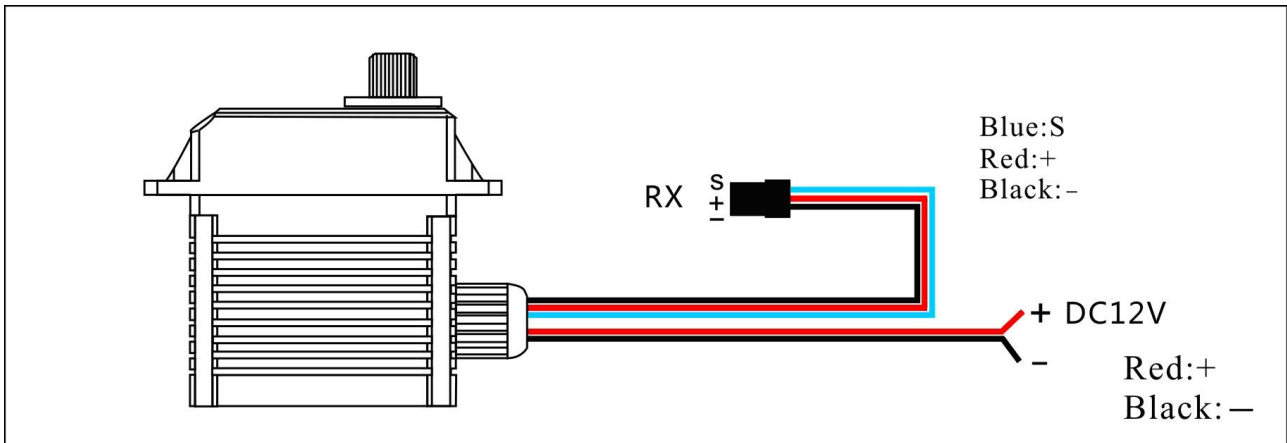

## Operating Data

	<b>X30-12-150</b>
<b>Operation Voltage(rated)</b>	DC12V
<b>Operation Voltage Range</b>	DC8.4-12V
<b>Torque</b>	105Kg.cm@8.4V
	150kg.cm@12V
<b>Speed</b>	0.18sec/60 °@8.4V
	0.13sec/60 °@12V
<b>Travel Angle</b>	±45° when 1000-2000us
<b>Operating Temperature Range</b>	-10°C……+55°C
	-40°C……+65°C (optional)

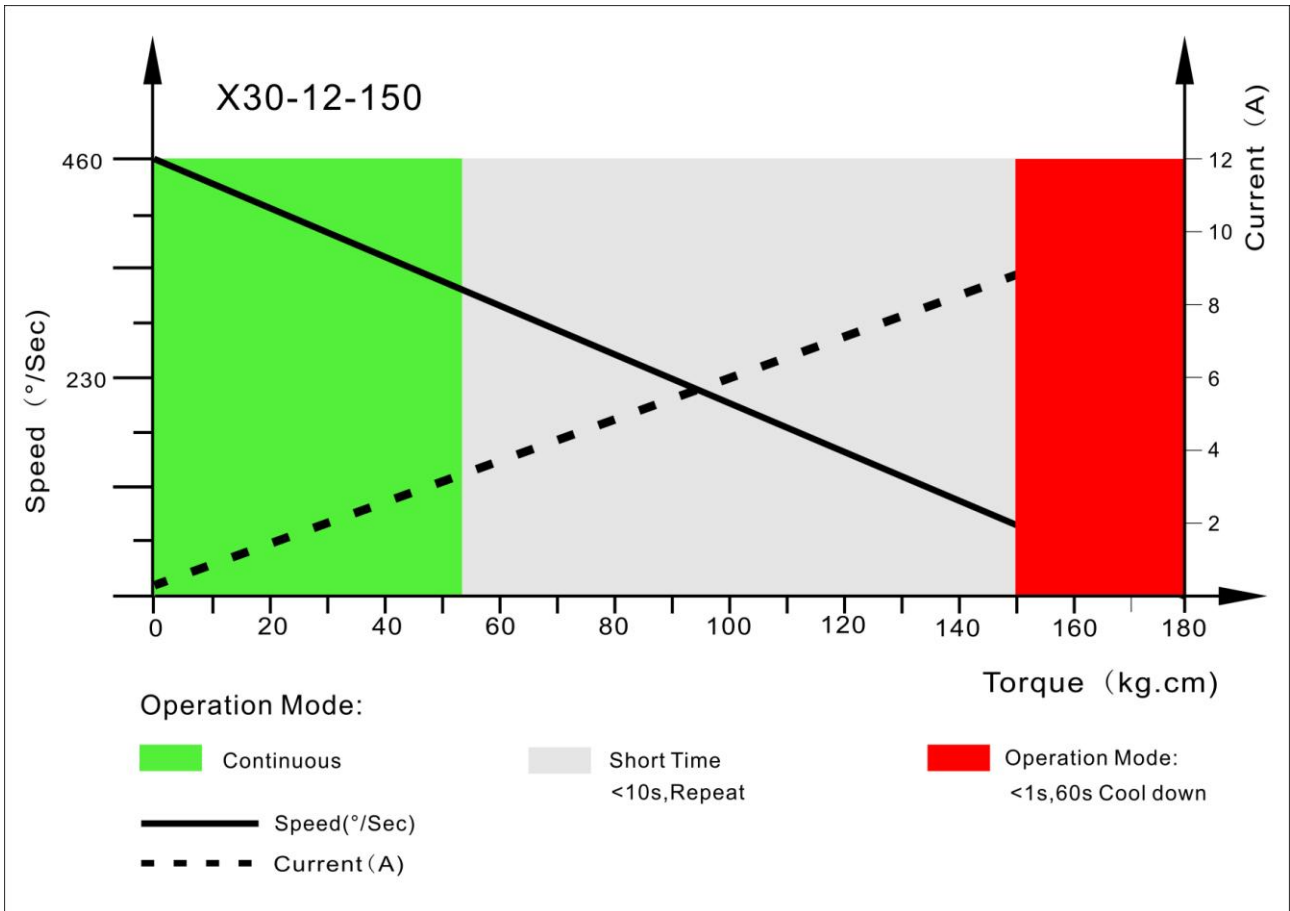

**PWM Command Signal**

<b>PWM</b>	<b>X30-12-150</b>
<b>Signal Voltage</b>	TTL-Level: HIGH:min.3.3V,max.5.0V TTL-Level: Low:min.0.0V,max.0.5V
Pulse Lengths	900-2100us
Pulse Lengths for Position $-45^{\circ}$ /center/ $+45^{\circ}$	1000us/1500us/2000us
Resolution	<2us

**Materials and protective features**

Case Material	Aluminum Alloy
Splash Surface Treatment	
Salt Water Resistance	
EMI/RFI Shielding	
Motor Type	Brushless
Gear Set Material	Steel
Position Sensor	Potentionmeter
Position Feedback	Optional
Shielded Connecting Cable	

**Dimensions**

Case Dimensions	64*33*74mm
Weight	360g

# 舵臂尺寸图

