

X30-12-120

Technical Specification

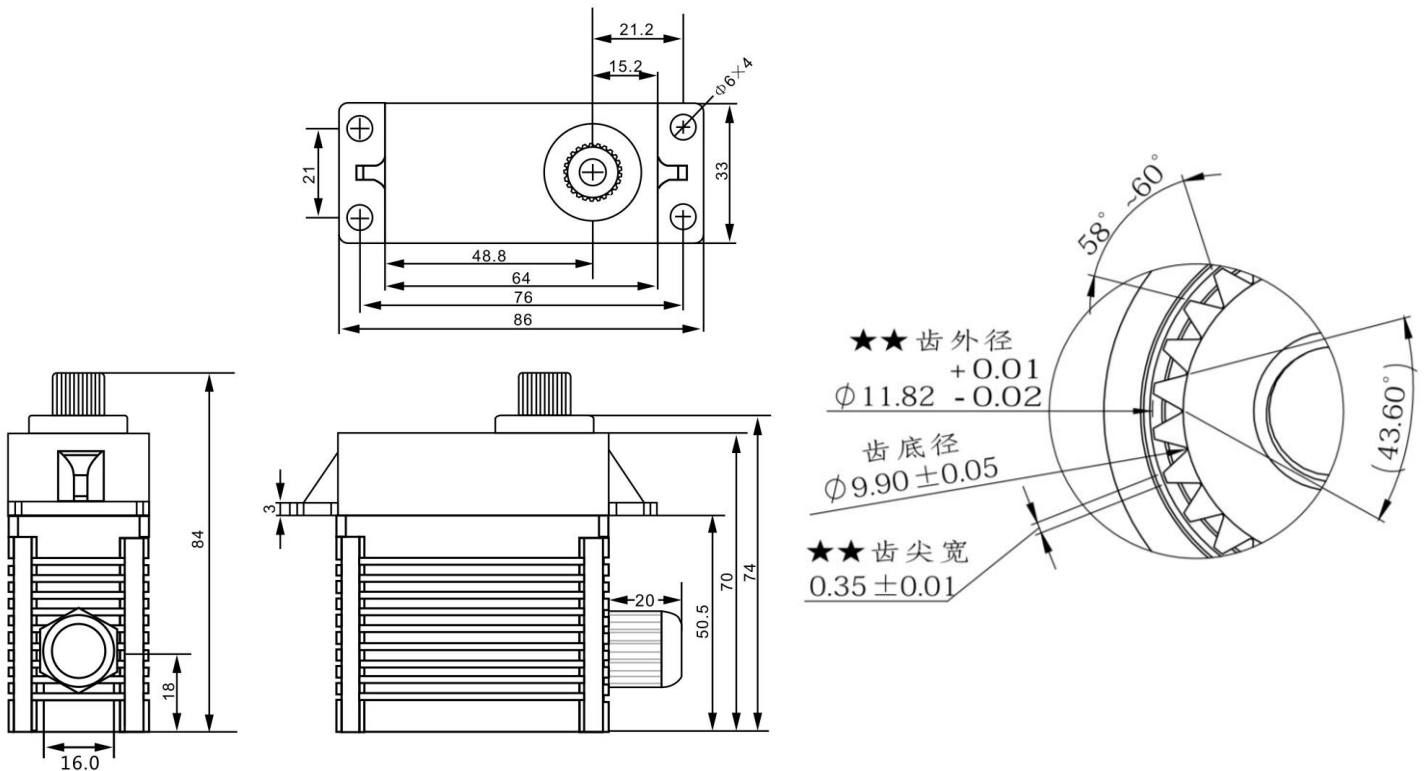

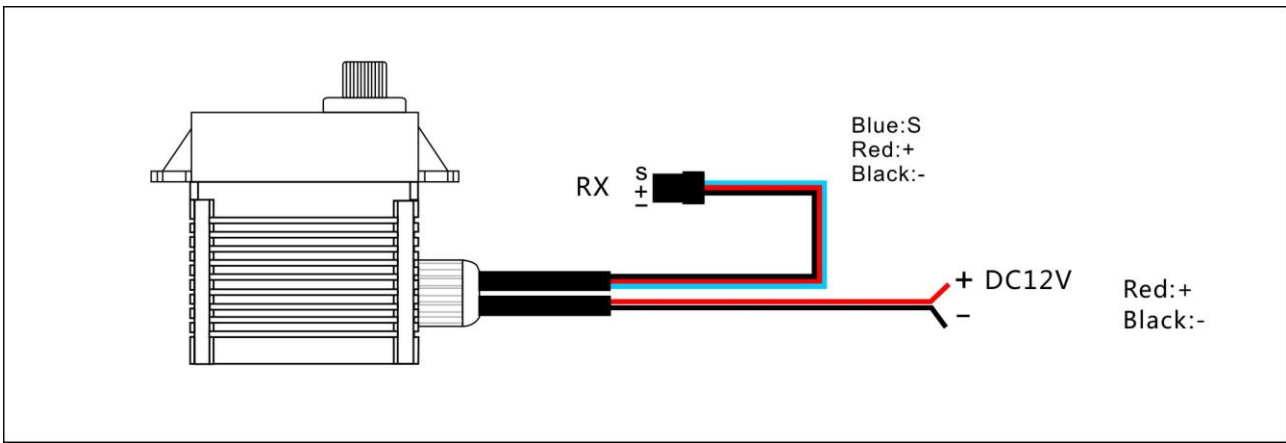

Operating Data

	X30-12-120
Operation Voltage(rated)	DC12V
Operation Voltage Range	DC8.4-12V
Torque	80Kg.cm@8.4V
	120kg.cm@12V
Speed	0.15sec/60 °@8.4V
	0.12sec/60 °@12V
Travel Angle	±45° when 1000-2000us
Operating Temperature Range	-10°C……+55°C
	-40°C……+65°C (optional)

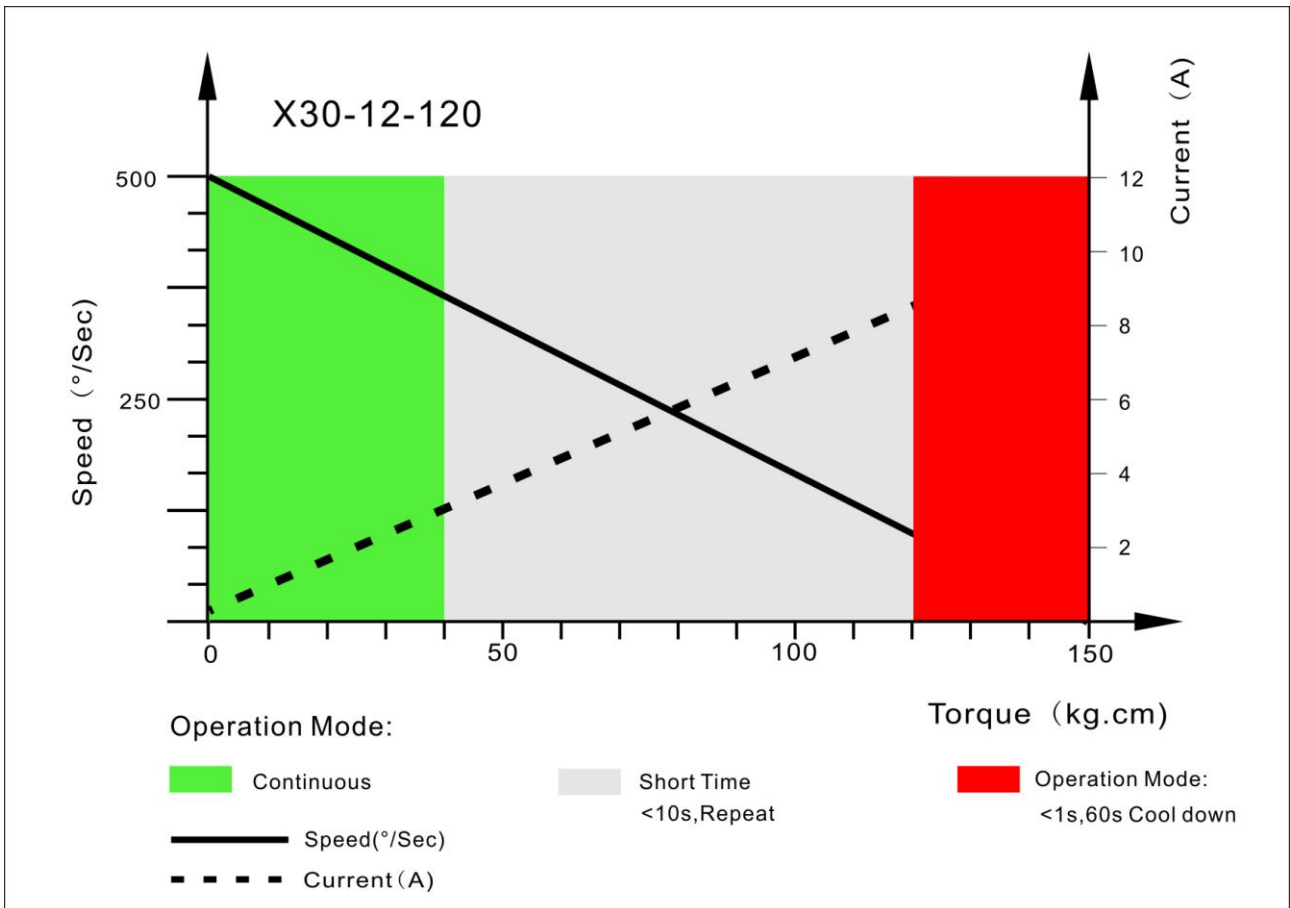



PWM Command Signal

PWM	X30-12-120
Signal Voltage	TTL-Level: HIGH:min.3.3V,max.5.0V TTL-Level: Low:min.0.0V,max.0.5V
Pulse Lengths	900-2100us
Pulse Lengths for Position -45° /center/ $+45^{\circ}$	1000us/1500us/2000us
Resolution	<2us

Materials and protective features

Case Material	Aluminum Alloy
Splash Surface Treatment	
Salt Water Resistance	
EMI/RFI Shielding	
Motor Type	Brushless
Gear Set Material	Steel
Position Sensor	Potentionmeter
Position Feedback	Optional
Shielded Connecting Cable	

Dimensions

Case Dimensions	64*33*74mm
Weight	360g

舵臂尺寸图

