

- NOTES:
 1. ASP-105990-03-B NOT AVAILABLE AS STANDARD.
 2. Ⓢ REPRESENTS A CRITICAL DIMENSION.
 3. Ⓢ COPLANARITY: SEE TABLE 1.
 4. BURR ALLOWANCE: .0015 MAX.
 5. MINIMUM PUSHOUT FORCE: .5 LB.
 6. MAXIMUM ALLOWABLE BOW: .002 INCH/INCH AFTER ASSEMBLY.
 7. CONTACT NOT ALLOWED TO PROTRUDE FROM TOP OF BODY.
 8. PARTS TO BE PACKAGED IN T&R.

REVISION

A	CW	C GRANTZ
4/27/2005	ECN-45799	
RELEASE FOR PRODUCTION		
B	TW	D DECKER
6/9/2006	ECN-60417	
REDRAW FOOTPRINT TO SHOW DOG BONE DETAILS SEEN ON THE YFTYFW FOOTPRINT.		

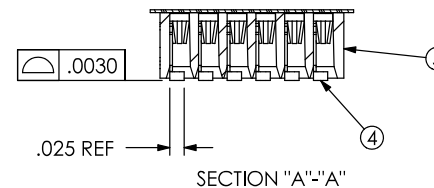
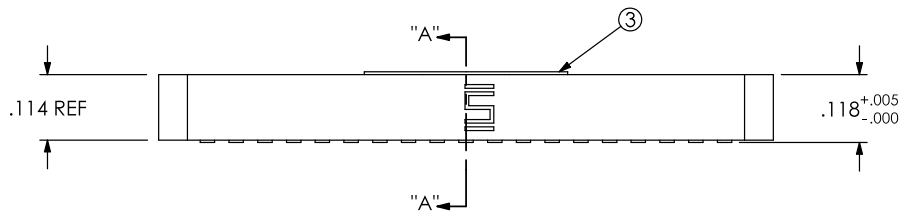
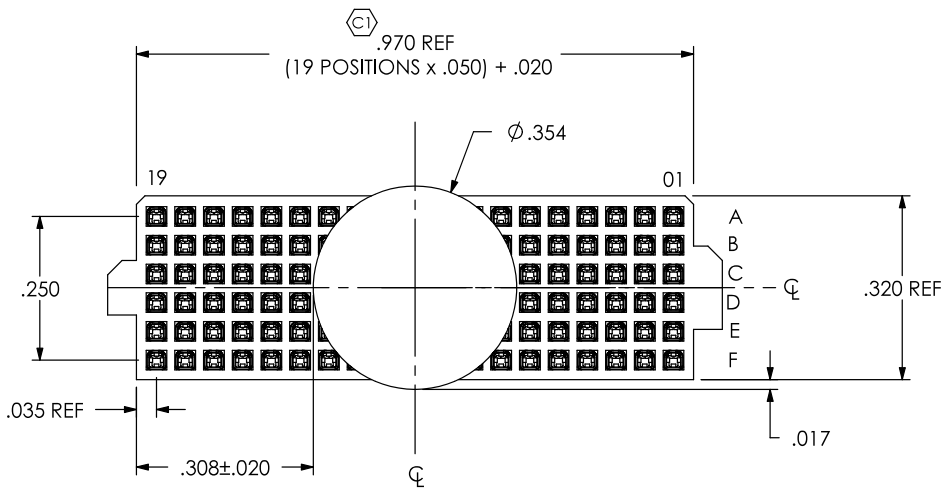
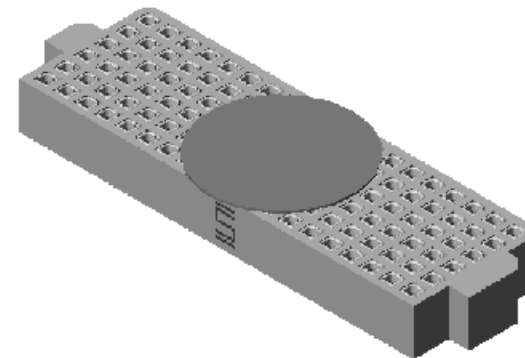

ACCEPTANCE OF DRAWING
 ACCEPTED WITH DEVIATIONS LISTED

DATE: _____
 COMPANY: _____
 CUSTOMER SIGNATURE _____
 PRINTED NAME _____
 PHONE NO: _____
 FAX NO: _____

ITEM NO.	PART NUMBER	QUANTITY	MATERIAL
1	ASP-105990-03-B	1.0000	VECTRA E130i, COLOR BLACK
2	C-118-01-H	114.00	BeCu #25, 1/2 HARD, AGE HARDENED
3	K-850-650	1.0000	POLYAMIDE FILM (KAPTON)
4	CT-ASP1233MS	1.0000	CONDUCTIVE POLYMER

UNLESS OTHERWISE SPECIFIED,
 DIMENSIONS ARE IN INCHES.
 TOLERANCES ARE:
 DECIMALS ANGLES
 .XX: ±.01[.3] 2°
 .XXX: ±.005[.13]
 .XXXX: ±.0020[.051]

PROPRIETARY NOTE

THIS DOCUMENT CONTAINS INFORMATION
 CONFIDENTIAL AND PROPRIETARY TO
 SAMTEC, INC. AND SHALL NOT BE REPRODUCED
 OR TRANSFERRED TO OTHER DOCUMENTS OR
 DISCLOSED TO OTHERS OR USED FOR ANY
 PURPOSE OTHER THAN THAT WHICH IT WAS
 OBTAINED WITHOUT THE EXPRESSED WRITTEN
 CONSENT OF SAMTEC, INC.

SAMTEC

520 PARK EAST BLVD, NEW ALBANY, IN 47150
 * PHONE: 812.944.6733 FAX: 812.948.5047
 e-Mail: INFO@SAMTEC.COM CODE: 55322

DO NOT SCALE DRAWING SHEET SCALE: 3:1

PLATING:
 CONTACT AREA: .000030 GOLD OVER .000050 NICKEL
 REMAINDER: .000003 FLASH GOLD OVER .000050 NICKEL



DESCRIPTION: .050 DUAL SOCKET ASSEMBLY

DWG. NO. ASP-105884-04

BY: WHITTAKER 4/27/2005 SHEET 1 OF 2

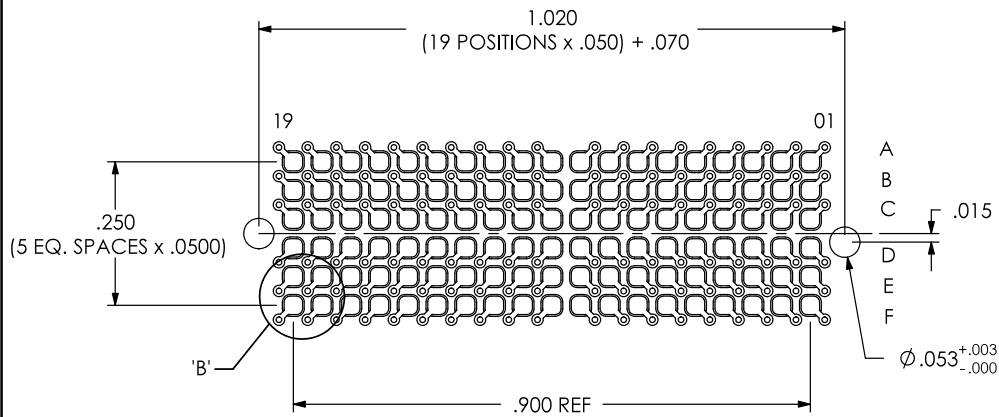

RECOMENDED BOARD LAYOUT

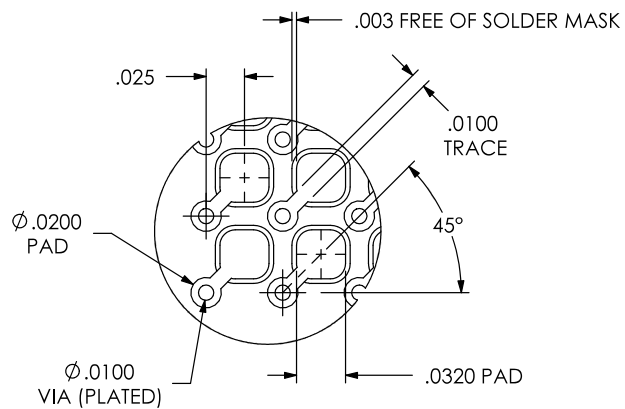

DETAIL 'B'
SCALE 8 : 1

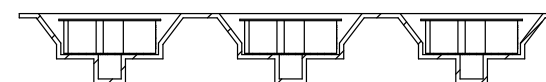
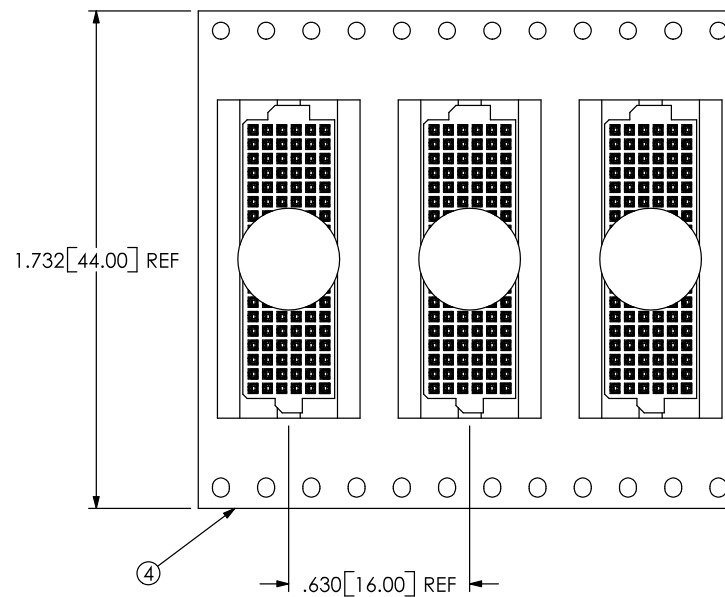

USER DIRECTION OF UNREELING →
POCKET NOT DETAILED

PACKAGING VIEW

PROPRIETARY NOTE

THIS DOCUMENT CONTAINS INFORMATION CONFIDENTIAL AND PROPRIETARY TO SAMTEC, INC. AND SHALL NOT BE REPRODUCED OR TRANSFERRED TO OTHER DOCUMENTS OR DISCLOSED TO OTHERS OR USED FOR ANY PURPOSE OTHER THAN THAT WHICH IT WAS OBTAINED WITHOUT THE EXPRESSED WRITTEN CONSENT OF SAMTEC, INC.

SAMTEC

520 PARK EAST BLVD, NEW ALBANY, IN 47150
* PHONE: 812.944.6733 FAX: 812.948.5047
e-Mail: INFO@SAMTEC.COM CODE: 55322

SHEET SCALE: 3:1



DESCRIPTION: .050 DUAL SOCKET ASSEMBLY

DWG. NO. ASP-105884-04

BY: WHITTAKER 4/27/2005

SHEET 2 OF 2