

DG01

Flow indicator with or without rotor, with wiper for cleaning of sight glass

- May be used for liquids and gases
- Compact design
- Available in brass and stainless steel
- May be installed in any position
- Available with or without rotor for visual flow confirmation
- With internal wiper blades for easy cleaning of the inside of the sight glass



Description:

Model series DG01 flow indicators are used to provide visual confirmation of flow in a pipe system. The flowing gas or liquid can be monitored through a sight glass. A rotor that is set in motion by the gas or liquid to provide visual confirmation of flow is available as an option. Wiper blades mounted in the flow indicator are pressed against the inside of the sight glass. The inside of the sight glass can easily be cleaned of deposits, algae or calcinations by simply rotating it by hand. This design feature allows regular cleaning without having to interrupt the process being monitored, making time-consuming and costly maintenance and cleaning unnecessary (no downtime).

Typical Applications:

DG01 mechanical flow indicators are used to monitor the flow of liquids of low to medium viscosity (up to 150 cSt) in pipe systems. The version of the DG01 with ball bearings is also suitable for use with gases.

Models:

DG01.x.1: without rotor
 DG01.x.2: with rotor

Materials: Available in brass or stainless steel

Nominal sizes and flow rates:

Con- nec- tion G	without rotor		with rotor		
	Qmax. (GPM / l/min)	Qmin. (GPM / l/m)			Qmax. (GPM / l/m)
		1 cSt	40 cSt	41-150 cSt	
1/4	3.20 / 12	0.10 / 0.4	0.53 / 2.0	0.80 / 3.0	1.0 / 4.0
3/8	4.75 / 18	0.16 / 0.6	0.53 / 2.0	0.80 / 3.0	2.1 / 8.0
1/2	7.90 / 30	0.26 / 1.0	0.80 / 3.0	0.92 / 3.5	3.2 / 12
3/4	16.0 / 60	0.26 / 1.0	0.80 / 3.0	0.92 / 3.5	6.6 / 25
1	24.0 / 90	0.42 / 1.6	0.80 / 3.0	0.92 / 3.5	10 / 40
1 1/4	40.0 / 150	2.10 / 8.0	1.00 / 4.0	1.32 / 5.0	21 / 80
1 1/2	58.0 / 220	2.10 / 8.0	1.32 / 5.0	1.32 / 5.0	26 / 100

Dimensions:

DG01.x.1

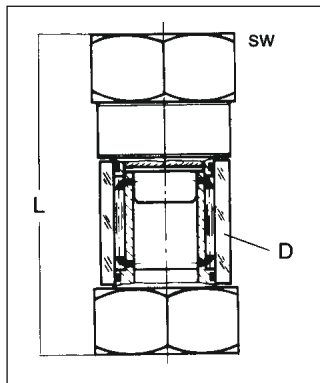

DG01.x.2

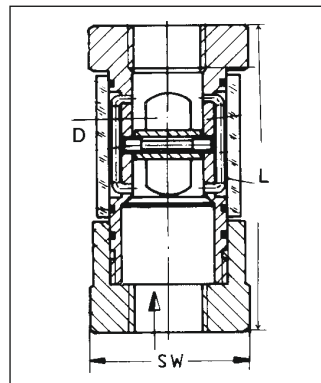

DG01.x. 1 (without rotor)				
Connection (G)	L (inch / mm)	A/F (inch / mm)	D (inch / mm)	Weight (lbs / kg)
1/4	2.80 / 71	1.42 / 36	1.18 / 30	0.66 / 0.3
3/8	2.80 / 71	1.42 / 36	1.18 / 30	0.66 / 0.3
1/2	3.39 / 86	1.81 / 46	1.57 / 40	1.32 / 0.6
3/4	3.70 / 94	1.81 / 46	1.57 / 40	1.32 / 0.6
1	4.09 / 104	1.81 / 46	1.57 / 40	1.32 / 0.6
1 1/4	4.72 / 120	2.56 / 65	2.56 / 65	3.30 / 1.5
1 1/2	5.12 / 130	2.56 / 65	2.56 / 65	3.52 / 1.6
DG01.x. 2 (with rotor)				
Connection (G)	L (inch / mm)	A/F (inch / mm)	D (inch / mm)	Weight (lbs / kg)
1/4	2.76 / 70	1.42 / 36	1.18 / 30	0.66 / 0.3
3/8	2.80 / 71	1.42 / 36	1.18 / 30	0.66 / 0.3
1/2	3.35 / 85	1.81 / 46	1.57 / 40	1.32 / 0.6
3/4	3.74 / 95	1.81 / 46	1.57 / 40	1.32 / 0.6
1	4.13 / 105	1.81 / 46	1.57 / 40	1.32 / 0.6
1 1/4	4.72 / 120	2.76 / 70	2.56 / 65	3.30 / 1.5
1 1/2	5.12 / 130	2.76 / 70	2.56 / 65	3.52 / 1.6

Model Coding:

Order Number: DG01 F. 2. 3. M

Flow indicator (with wiper-type cleaning system)

Monitored media (liquid, gas):
 (for version without rotor, select 0)

F = Liquids
 G = Gases

Models:

1 = without rotor
 2 = with rotor

Connection:

1 = G1/4 female thread
 2 = G3/8 female thread
 3 = G1/2 female thread
 4 = G3/4 female thread
 5 = G1 female thread
 6 = G1-1/4 female thread
 7 = G1-1/2 female thread

Materials:

M = Brass
 E = Stainless steel

Technical Specifications:

Max. pressure: 232 psi / 16 bar
 Pressure loss:
 DG01.x.1: 2.9 psi / 0.2 bar
 DG01.x.2: 3.6 psi / 0.25 bar
 Max. Temperature: 212 °F / 100 °C

Materials:

Housing

DG01.x.x.x.M: Brass MS 58 nickel plated
 DG01.x.x.x.E: Stainless steel 1.4305

Sight Glass

DG01.x.1: Duran glass
 DG01.x.2: Borosilicate glass

Wipers:

DG01.x.x.x.M: Buna
 DG01.x.x.x.E: Viton

O-Ring:

DG01.x.x.x.M: Buna
 DG01.x.x.x.E: Viton

Rotor (DG01.x.2.x only):

PVDF, red; Nylon, white for
 G 1 1/4 - G 1 1/2

Bearing:

Sleeve bearing made of PEEK for
 liquids; Ball bearing, grease-free,
 for gases

Installation position:

any

Sight glasses for smaller flows and higher operating
 temperatures are available upon request.