

FUM10

Ultrasonic Level Sensor

- Rugged, heavy-duty device housed in a plastic enclosure
- Measuring ranges from 60 – 500 to 600 – 6,000 mm
- 4 – 20 mA analog output, can be programmed by TEACH-IN
- Power supply 12 – 30 VDC



Description:

Ultrasonic level sensors measure the clearance between a liquid level and the sensor's transmission surface using the echo time measurement of an ultrasonic signal. Liquid levels can be measured and the data sent to master evaluators by means of a programmable current or voltage output. For operating ranges up to 2m, the devices are available in an M18 enclosure incl. two lock nuts that is easy to install. For an operating range up to 3.5m, we offer an M30 enclosure. The sensor with 6m operating range has an enclosure with square flange and an extra large transmission surface.

Typical Applications:

FUM10 ultrasonic level sensors are suitable for applications where liquid levels in depressurized vessels are monitored, measured or regulated.

Models:

FUM10...S: electrical connection
M12 industrial plug

FUM10...K: with cable connector

Operating ranges:

Model	Measuring range	Response time (90%) in ms	Electrical protection
FUM10.K.05...	60...500 mm	100	IP67
FUM10.K.08...	100...800 mm	100	IP67
FUM10.K.20...	200...2,000 mm	200	IP67
FUM10.K.35...	350...3,500 mm	400	IP67
FUM10.K.60...	600...6,000 mm	700	IP65

Dimensions:

FUM10.K.5... to FUM10.K.20...

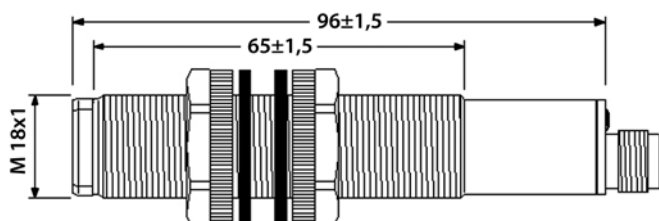

FUM10.K.35: enclosure M30 x 1.5, length 125 mm

FUM10.K.60...

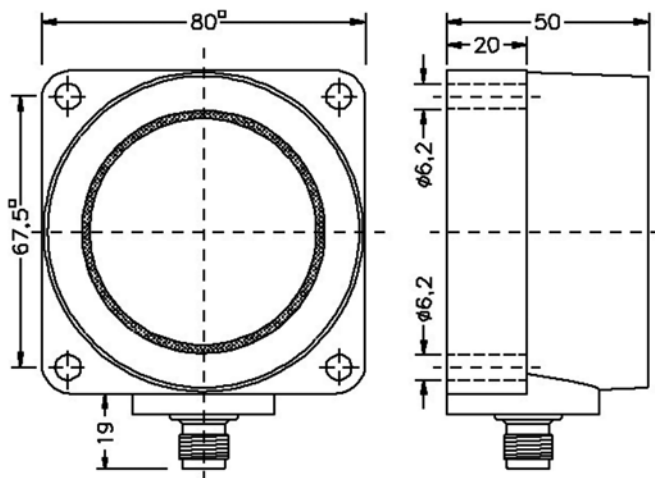

Electrical Connection:

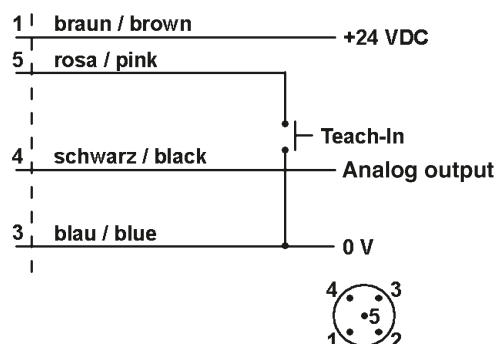

Model Coding:

Order number: FUM10. K. 20. I. S. 0

Ultrasonic level sensor

Material:

K = plastic enclosure

S = special-order device

Measuring range:

05 = 60 – 500 mm

08 = 100 – 800 mm

20 = 200 – 2,000 mm

35 = 350 – 3,500 mm

60 = 600 – 6,000 mm

Output signal:

I = current output 4 - 20 mA

V = voltage output 0 - 10 V

Electrical connection:

S = plug M12 x 1, 5-pin

K = cable, 5-core, 2m (not for FUM10.K.60)

Options:

0 = none

1 = matching plug, 5-pin, with 2 m cable

2 = matching plug, 5-pin, with 2 m cable, right-angled

9 = please specify in writing

Specifications:

Materials: enclosure made of PET / PBT, sonic converter made of glass / ceramic, potting compound is epoxy resin

Supply voltage: 12 to 30 VDC

Electrical connection: plug M12 or 1.5 m cable

Process connection:

FUM10.K.05...20: screw thread M18 incl. 2 lock nuts

FUM10.K.35: screw thread M30 incl. 2 lock nuts

FUM10.K.60: 4-hole square flange 67.5 x 67.5 mm

Outputs: analog output, 4 – 20 mA or 0 – 10 V

Resolution:

FUM10.K.05...08: 0.25 mm

FUM10.K.20...35: 1 mm

FUM10.K.60: 1.5 mm

Indicator: 3 LED, echo, beginning and end of characteristic

Repeat accuracy:

FUM10.K.05...35: ± 0.2% ± 1 mm

FUM10.K.60: ± 0.2% ± 2 mm

max. pressure: atmospheric

Temperature range:

-15...+70 °C, compensated