

FS10

Vertically-Mounted Magnetic Float Level Sensor

- reliable and robust, heavy-duty technology
- mounting thread, tank fitting or flange
- installation at top or bottom of vessel
- plastic, brass or stainless steel models
- NC, NO or changeover contacts available



Description:

The FS10 level sensor is based on a float with magnetic transmission technology. The sensor is comprised of a guide tube with embedded Reed contacts, one or more floats with fitted ring magnets and a process connection module. The float is raised by the rising liquid in the tank and operates a Reed contact through the guide tube wall by means of the magnetic field produced by permanent magnets located in the float. This Reed contact can be designed as a NO, NC or changeover function.

Typical Applications:

FS10 magnetic float level sensors are suitable for monitoring the level of practically all liquids, e.g. as a full or empty tank sensor, for controlling valves and pumps and for alarm function. The potential free Reed contacts fitted in the level sensor make it an ideal control element when coupled with PLC controllers.

Function:

A ring magnet installed in the float operates Reed contacts, which are embedded at defined positions in the guide tube, via its magnetic field through the walls of the guide tube. Float stops mounted on the guide tube prevent the float from passing the contact – this assures bistable switching. Consequently, a maximum of 2 contacts per float can be operated. If more contacts are fitted, more floats must be used.

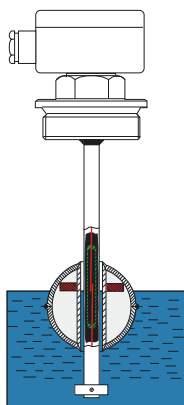

Versions:

Materials:

Standard: brass or stainless steel, PVC, PP or PVDF

Food / hygienic: stainless steel with Tri-Clamp or dairy pipe fitting

Each magnetic float level sensor consists of the three key modules below, which, depending on requirements, are available in different models:

- guide tube
- float
- process connection

Secondary instrumentation like contact protection relays complete the measuring system.

Guide tube:

The guide tube is the key component in the level sensor: it houses the reed contacts and can be supplied in a variety of materials and diameters.

Materials and diameters:

- brass (ø 0.31" / 8 mm, 0.47" / 12 mm, 0.55" / 14 mm, 0.71" / 18 mm)
- stainl. steel (ø 0.31" / 8 mm, 0.47" / 12 mm, 0.55" / 14 mm, 0.71" / 18 mm)
- PVC (ø 0.31" / 8 mm, 0.47" / 12 mm, 0.63" / 16 mm, 0.79" / 20 mm)
- PP (ø 0.31" / 8 mm, 0.47" / 12 mm, 0.63" / 16 mm, 0.79" / 20 mm)
- PVDF (ø 0.47" / 12 mm, 0.63" / 16 mm, 0.79" / 20 mm)

Guide tube Ø	Max. number of contacts	
	NO contact / NC contact	Changeover contact
0.31" / 8 mm	3	1
0.47" / 12 mm	4	4
0.55" / 14 mm	4	4
0.63" / 16 mm	5	6
0.71" / 18 mm	8	8
0.79" / 20 mm	8	8

Float:

The choice of float is based on the liquid being monitored (corrosion, density), the process parameters (pressure, temperature) and the guide tube materials and diameters. The available float models are listed in the following table.

Float models and dimensions (table 1):

Model	Material	Shape	Ø ID/AD (inch / mm)	Min. density (kg/m ³)	Max. pressure (psi / bar)	Max. temp. (°F / °C)
E1027	stainless steel	cylinder	0.39-1.06 / 10-27	800	87 / 6	392 / 200
E1544	steel		0.59-1.73 / 15-44	800	363 / 25	392 / 200
T1444	titanium		0.55-1.73 / 14-44	750	218 / 15	302 / 150
A1544	alloy		0.59-1.73 / 15-44	1000	653 / 45	392 / 200
B0925	Buna		0.35-0.98 / 9-25	800	87 / 6	176 / 80
B1540			0.59-1.57 / 15-40	700	87 / 6	176 / 80
PV1444	PVC		0.55-1.73 / 14-44	800	14 / 1	140 / 60
PV2255			0.87-2.17 / 22-55	750	14 / 1	140 / 60
PV2580	PP		0.98-3.15 / 25-80	600	14 / 1	140 / 60
PP2155			0.83-2.17 / 21-55	600	14 / 1	176 / 80
PP2480			0.94-3.15 / 24-80	500	14 / 1	176 / 80
PF2155	PVDF		0.83-2.17 / 21-55	800	14 / 1	212 / 100
PF2480			0.94-3.15 / 24-80	700	14 / 1	176 / 80
E0942	stainless steel		sphere	0.37-1.65 / 9.4-42	650	218 / 15
E1552		0.59-2.05 / 15-52		700	580 / 40	392 / 200
E1562		0.59-2.44 / 15-62		600	363 / 25	392 / 200
E1572		0.59-2.83 / 15-72		460	363 / 25	392 / 200
E2398		0.91-3.86 / 23-98		560	363 / 25	392 / 200
T1244		titanium		0.47-1.73 / 12-44	780	1450 / 100
T1552	0.83-2.17 / 15-52			750	2175 / 150	572 / 300
T2480	0.83-2.17 / 24-80			600	232 / 16	302 / 150

Special-order floats (ECTFE coated) are available on request

Process connection:

Typically, the magnetic float level sensors are screwed in the top of the vessel from inside with a male-threaded fitting (NPT or G, 1/8" to 2"). When installed in this fashion, the devices are supplied with a PVC or silicone-jacket connection cable. To mount the float level sensor from outside through the top of the vessel the device must be fitted with a tank fitting (NPT or G, 1", 1 1/2", or 2" male thread) or with flanges. The diameter of the tank fitting or flange must be large enough to allow the float to pass through the opening in the top of vessel.

Min. pipe sizes for process connection (table 2):

Float model	Minimum pipe size	
	Tank fitting (NPT/G)	Flange (ANSI / DIN)
E1027	1"	1 1/2" / DN40
E1544	1 1/2"	2" / DN50
T1444	1 1/2"	2" / DN50
A1544	1 1/2"	2" / DN50
B0925	1"	1" / DN25
B1540	1 1/2"	2" / DN50
PV1444	1 1/2"	2" / DN50
PV2255	2"	2 1/2" / DN65
PV2580	---	3" / DN80
PP2155	2"	2 1/2" / DN65
PP2480	---	3" / DN80
PF2155	2"	2 1/2" / DN65
PF2480	---	3" / DN80
E0942	1 1/2"	2" / DN50
E1552	2"	2 1/2" / DN65
E1562	---	2 1/2" / DN65
E1572	---	3" / DN80
E2398	---	4" / DN100
T1244	1 1/2"	2" / DN50
T1552	2"	2 1/2" / DN65
T2480	---	4" / DN100

Technical specifications for process connections:

Mounting thread on top, cable connection (table 3)

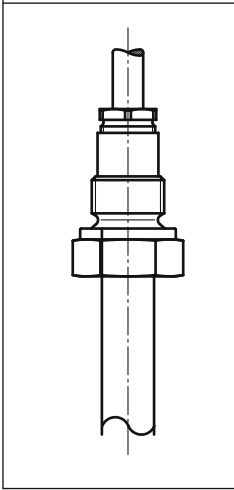

Brass or stainless steel

male-threaded fitting G or NPT
1/8" to 2" (code G or N)
max. pressure: see "Float" table
max. temperature: see "Float" table

Con-nection	Material	Code G... N...	Guide tube Ø (inch / mm)	Max. length (inch / mm)
1/8"	Brass	...06	0.31 / 8	40 / 1000
	st. steel			40 / 1000
3/8"	Brass	...10	0.31-0.47-0.55 / 8-12-14	40 / 1000
	st. steel			200 / 5000
1/2"	Brass	...15	0.31-0.47-0.55-0.71 / 8-12-14-18	40 / 1000
	st. steel			200 / 5000
1"	Brass	...25	0.31-0.47-0.55-0.71 / 8-12-14-18	40 / 1000
	st. steel			200 / 5000
1 1/2"	Brass	...40	0.31-0.47-0.55-0.71 / 8-12-14-18	40 / 1000
	st. steel			200 / 5000
2"	Brass	...50	0.31-0.47-0.55-0.71 / 8-12-14-18	40 / 1000
	st. steel			200 / 5000

Mounting thread on top, cable connection (table 4)

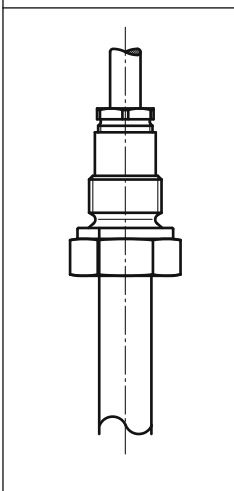

PVC, PP or PVDF

male-threaded fitting G or NPT
1/8" to 2" (code G or N)
max. pressure: 14.5 psi / 1 bar
max. temperature: see "Float" table

Con-nection	Material	Code G... N...	Guide tube Ø (inch / mm)	Max. length (inch / mm)
1/8"	PVC/PP	...06	0.31-0.47 / 8-12	40 / 1000
	PVDF	---		
3/8"	PP	...10	0.31-0.47 / 8-12	40 / 1000
	PVDF	...10		
1/2"	PVC/PP	...15	0.63-0.79 / 16-20	40 / 1000
	PVDF	...15		
1"	PVC/PP	...25	0.63-0.79 / 16-20	40 / 1000
	PVDF	...25		
1 1/2"	PVC/PP	...40	0.63-0.79 / 16-20	40 / 1000
	PVDF	...40		
2"	PVC/PP	...50	0.63-0.79 / 16-20	40 / 1000
	PVDF	...50		

Tank fitting with connection box (table 5)

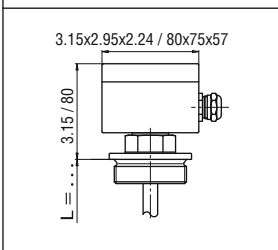

Tank fitting with plug connector made of ABS as per EN 175301-803, Form A (table 6)

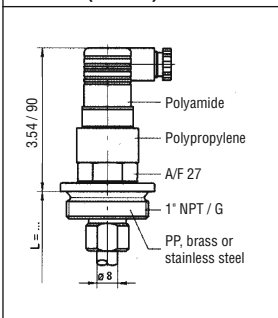

Brass or stainless steel

male-threaded fitting G or NPT,
1" to 2"
with connection box: code TG or TN
with plug: code TSG or TSN
max. pressure: 40 bar
max. temperature: see "Float" table

Con-nection	Material	Code TG... TN... TSG... TSN...	Guide tube Ø (inch / mm)	Max. length (inch / mm)
1"	Brass	...25	0.31-0.47-0.55-0.71 / 8-12-14-18	40 / 1000
	st. steel			200 / 5000
1 1/2"	Brass	...40	0.31-0.47-0.55-0.71 / 8-12-14-18	40 / 1000
	st. steel			200 / 5000
2"	Brass	...50	0.31-0.47-0.55-0.71 / 8-12-14-18	40 / 1000
	st. steel			200 / 5000

Tank fitting with polyester connection box (table 7)

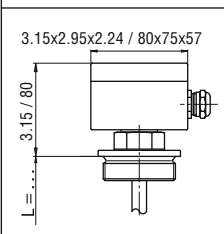

Tank fitting with plug connector made of ABS as per EN 175301-803, Form A (table 8)

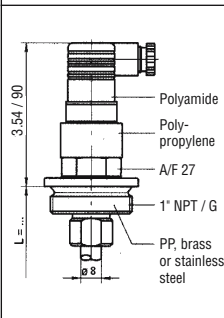

PVC, PP or PVDF

male-threaded fitting G or NPT
1" to 2"
with connection box: code TG or TN
with plug: code TSG or TSN
max. pressure: 1 bar
max. temperature: see "Float" table

Con-nection	Material	Code TG... TN... TSG... TSN...	Guide tube Ø (inch / mm)	Max. length (inch / mm)
1"	PVC	...25	0.31-0.47-0.63-0.79 / 8-12-16-20	31.5/800
	PP			158/4000
	PVDF			31.5/800
1 1/2"	PVC	...40	0.31-0.47-0.63-0.79 / 8-12-16-20	20/500
	PP			129/3000
	PVDF			31.5/800
2"	PVC	...50	0.31-0.47-0.63-0.79 / 8-12-16-20	158/4000
	PP			31.5/800
	PVDF			158/4000

Flange connection with connection box (table 9)

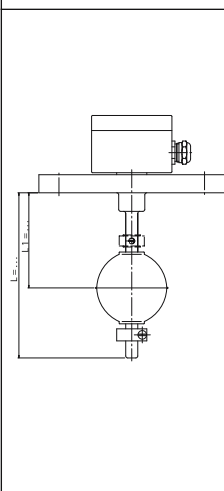

Carbon steel or stainless steel

flanges as per ANSI or DIN
1" (DN25 to 4" (DN100)
ANSI 150 lbs., RF: code FA150...
ANSI 300 lbs., RF: code FA300...
DIN PN 16: code FD16...
DIN PN 40: code FD40...
max. pressure: see "Float" table
(please observe flange pressure rating)
max. temperature: see "Float" table

Con-nection	Material	Code FD16... FD40... FA150... FA300...	Guide tube Ø (inch / mm)	Max. length (inch / mm)
1"	Steel	...25	0.31-0.47-0.55-0.71 / 8-12-14-18	40 / 1000
	st. Steel			200 / 5000
1 1/2"	Steel	...40		40 / 1000
	st. Steel			200 / 5000
2"	Steel	...50		40 / 1000
	st. Steel			200 / 5000
2 1/2"	Steel	...65		40 / 1000
	st. Steel			200 / 5000
3"	Steel	...80		40 / 1000
	st. Steel			200 / 5000
4"	Steel	...100	40 / 1000	
	st. Steel		200 / 5000	

Special-order versions:

- dairy pipe fitting as per DIN 11851 with aluminum connection box
- Tri-Clamp connection as per DIN 32676 with plug made of ABS as per EN 175301-803, Form A

Model Coding:

Order Number: FS10.1.1.1.G06.1.1.0.E1027.XXX

Magnetic float level sensor

Guide tube material:

- 1 = brass
- 2 = stainless steel
- 3 = PVC
- 4 = PP
- 5 = PVDF
- 6 = PA
- 9 = special-order

Guide tube diameter:

- 1 = 0.31" / 8 mm
- 2 = 0.47" / 12 mm
- 3 = 0.55" / 14 mm
- 4 = 0.63" / 16 mm
- 5 = 0.71" / 18 mm
- 6 = 0.79" / 20 mm
- 9 = special-order

Process connection material:

- 1 = brass
- 2 = carbon steel
- 3 = stainless steel
- 4 = PVC
- 5 = PP
- 6 = PVDF
- 9 = special-order

Connection code: (see tables 3 to 9)

- G06 to FA300
- 9 = special-order

Electrical connection:

- 1 = aluminum connection box
- 2 = stainless steel connection box
- 3 = ABS connection box
- 4 = plug connector (max. 1 switch contact)
- 5 = plug connector with PA flange (max. 1 switch contact)
- 6 = 1 m connection cable *
- 9 = special-order

Contacts (from top to bottom):**

- 1 = N/O contact for rising level
- 2 = N/C contact for rising level
- 3 = changeover contact for rising level

Temperature contact at end of guide tube:

- 0 = none
- 1 = N/O contact for rising temperature***
- 2 = N/C contact for rising temperature***
- 9 = special-order

Float model:

E1027-T2480
(see table 1)

Approvals and options:

- 0 = none
- xx = see "Approvals and options" table

* standard PVC, optionally silicone jacket, PUR, FEP screened or oil-resistant; (please specify material and other cable lengths)
 ** please specify distance of contacts measured from sealing edge of process connection for each contact
 *** please specify setpoint temperature

Model Coding (process connections):

Mounting thread above sealing edge of process connection with cable connection

G 10

- G = male-threaded fitting G
- N = male-threaded fitting NPT

- 06 = 1/8"
- 10 = 3/8"
- 15 = 1/2"
- 25 = 1"
- 40 = 1 1/2"
- 50 = 2"

Tank fitting:

TG 25

- TG = with connection box, male-threaded fitting G
- TN = with connection box, male-threaded fitting NPT
- TSG = with plug connector, male-threaded fitting G
- TSN = with plug connector, male-threaded fitting NPT

- 25 = 1"
- 40 = 1 1/2"
- 50 = 2"

Flange connection with connection box:

FD16 -40

- FD16 = DIN flange, PN16
- FD40 = DIN flange, PN40
- FA150 = ANSI flange, 150 lbs., RF
- FA300 = ANSI flange, 300 lbs., RF
- FS = special-order flange

- 25 = 1" / DN25
- 40 = 1 1/2" / DN40
- 50 = 2" / DN50
- 65 = 2 1/2" / DN65
- 80 = 3" / DN80
- 100 = 4" / DN100

Float level switch made of brass or stainless steel



with male-threaded fitting and cable connector

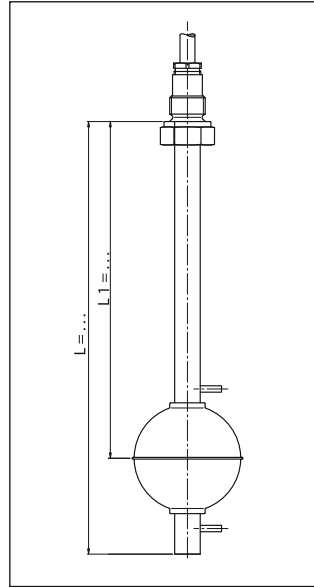

with tank fitting and connection box

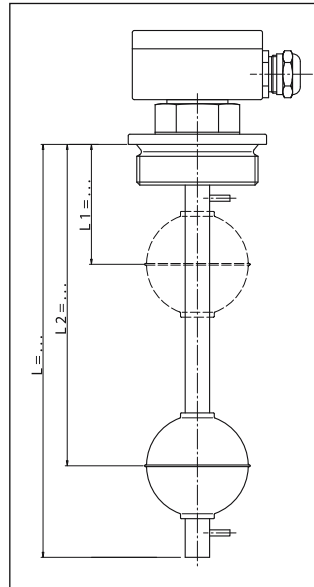

with flange and connection box

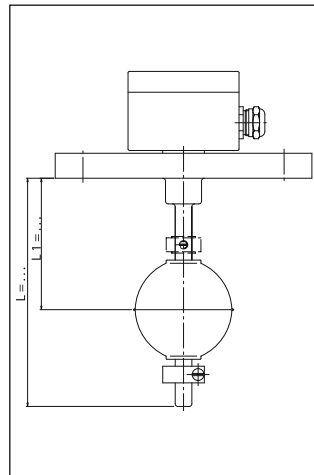

Models and technical specifications

Guide tube material: brass or stainless steel 316 Ti / 1.4571

Guide tube diameter: brass: 0.31"-0.47"-0.55" / 8-12-14 mm
stainless steel: 0.31"-0.47"-0.55"-0.71" / 8-12-14-18 mm

Length of guide tube: Ø 0.31" / 8 mm: max. 40" / 1 m
Ø 0.47" / 12 mm, Ø 0.55" / 14 mm: max. 118" / 3 m
Ø 0.71" / 18 mm: max. 236" / 6 m

Float:

Guide tube diameter			
0.31" / 8 mm	0.47" / 12 mm	0.55" / 14 mm	0.71" / 18 mm
E1027	E1544	E1544	E2398
B0925	T1444	A1544	T2480
E0942	A1544	B1540	
T1244	B1540	E1552	
	PV1444	E1562	
	E1552	E1572	
	E1562	T1552	
	E1572		
	T1552		

Process connection: mounting thread made of brass or stainless steel, see table 3
tank fittings made of brass or stainless steel, see tables 5 or 6
flanges made of carbon steel or stainless steel, see table 9
special-order versions: Tri-Clamp, dairy pipe on request

Max. pressure: depending on float
(see table 1 – Float models)

Max. temperature: cable material:
(process connection: PVC: 176 °F / 80 °C
male-threaded fitting with cable) silicone: 356 °F / 180 °C
PUR: 176 °F / 80 °C
FEP: 392 °F / 200 °C
other materials available on request
(please observe max. temperature of float)

max. temperature: depending on float
(process connection: (see table 1 - float models),
tank fitting or flange) however max. 302 °F / 150 °C for brass and 392 °F / 200 °C for stainless steel guide tube.
special-order versions for higher temperatures available on request

Other details: function and location of contacts, measured from sealing edge of connection, and overall length of guide tube, temperature switchpoint

Float sensor made of PVC, PP or PVDF



with male-threaded fitting and cable connector

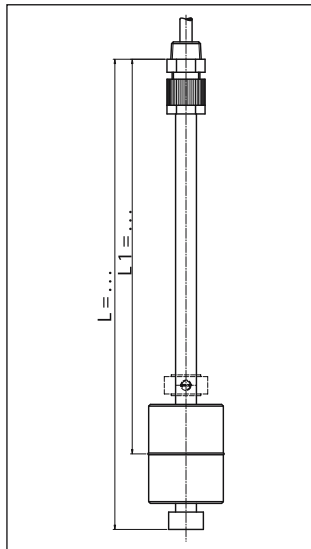

with tank fitting and ABS connection box

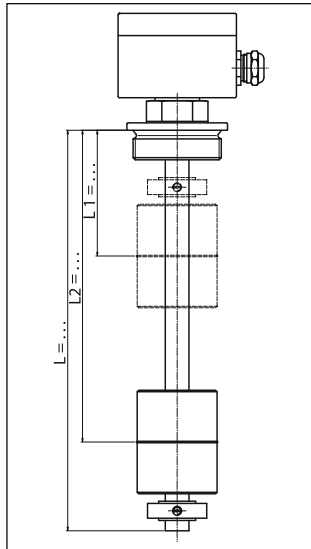

Models and technical specifications

- Guide tube materia:** PVC, PP or PVDF
- Guide tube diameter:** 0.31" / 8 mm, 0.47" / 12 mm, 0.63" / 16 mm, 0.79" / 20 mm
- Length of guide tube:** 0.31" / 8 mm, 0.47" / 12 mm: max. 118" / 3 m
0.63" / 16 mm, 0.79" / 20 mm: max. 157" / 4 m

Float:

Guide tube diameter			
0.31" / 8 mm	0.47" / 12 mm	0.63" / 16 mm	0.79" / 20 mm
B0925	B1540	PP2155	PV2255
PV1444	PF2155	PV2580	
		PP2480	
		PF2480	

Process connection:

mounting thread made of PVC, PP or PVDF, see table 4
tank fittings made of PVC, PP or PVDF, see tables 7 or 8

Max. pressure:

1 bar

max. temperature:

PVC: 140 °F / 60 °C, PP, PVDF: 176 °F / 80 °C (please observe max. temperature of float)

Other details:

function and location of contacts, measured from sealing edge of connection, and overall length of guide tube, temperature switchpoint

Switch rating of Reed contacts

Switch function	Guide tube diameter				
	0.31" / 8 mm	0.47" / 12 mm	0.55" / 14 mm	0.63" / 16 mm	0.79" / 20 mm
N/O contact	150 V, 0,5 A, 10 VA	230 V, 0,5 A, 40 VA			
NC contact	150 V, 0,5 A, 10 VA	230 V, 0,5 A, 40 VA			
SPDT contact	150 V, 0,5 A, 10 VA	230 V, 0,5 A, 40 VA			

Contacts with higher switch rating and with load resistor for connection to a PLC are available on request

Approvals and options

Description	Code	for model
intrinsically safe model as per Eex ia / Exx ib	E1	Please inquire as required
intrinsically safe model as per Eex ia with dust-Ex	E2	
Water Resources Act	WH	
German Lloyd	GL	
Bureau Veritas	BV	
Registrato Italiano Navale	RIN	
with test function	T	
vertically adjustable model	HA	
PT100 temperature sensor, 3-wire in bottom of guide tube (pl. specify measuring range)	P	
20 mA-transmitter in connection box for devices with PT100 temperature sensor	PM	