

# DPS10

## Paddle-bellows type flow switch

- Proven technology
- Easy installation
- Causes only slight pressure loss
- Constructed of brass and stainless steel
- Can be installed in any position



### Description:

The flow switches model DPS10 transmit the flow-dependent displacement of the paddle installed in the piping by means of a bellows and a spring-loaded rocker mechanically connected to a heavy-duty microswitch. The switching point can be changed by adjusting the spring preload. The three standard paddles can be used in piping with nominal size of 1" to 3". A fourth paddle can be used for larger nominal sizes or to reduce the switching values through appropriate shortening to the desired length. In addition, DPS10 is available in a design with a reduced adjustment range, so that it can also be used for minimum switching values.

### Fields of application:

DPS10 paddle switches can be used wherever reliable monitoring of liquid flow is required. The switches are used for monitoring both minimum and maximum flow. Typical application areas are the monitoring of cooling and lubrication circuits, dry-running protection for pumps or for monitoring loss of flow. Their sturdy construction allows them to be reliably used in many industrial applications.

## Designs:

### DPS10 Paddle-bellows type flow switch

**Material combination:** the standard version, DPS10.1, is suitable for monitoring non-caustic/non-corrosive liquids. DPS10.1 has a brass housing, a bellows made of red brass, and 4 variably adjustable paddles made of 1.4301 stainless steel.

The stainless steel version, DPS10.2, is suitable for monitoring caustic/corrosive liquids. DPS10.2 has a housing made of 1.4301 stainless steel, a bellows of 1.4301 stainless steel and 4 variably adjustable paddles made of 1.4301 stainless steel.

The third version, DPS10.3, is suitable for monitoring air flow. DPS10.3 has a brass housing, a bellows made of red brass, and paddle of stainless steel 1.4301 suitable for flow velocities of 1-8 m/s.

**Adjustment range:** measuring ranges for the standard version and the version with a reduced measuring range are listed in the table below.

Pipe diameter in mm	Type	Q <sub>max.</sub> in m <sup>3</sup> /h	Adjustment range in m <sup>3</sup> /h	Adjustment range reduced in m <sup>3</sup> /h	Paddle
25	DPS10.1 and DPS10.2	3.6	0.6 - 2	0.2 - 1	1
32	DPS10.1 and DPS10.2	6	0.8 - 2.8	0.25 - 1.4	1
40	DPS10.1 and DPS10.2	9	1.1 - 3.7	0.5 - 1.9	1
50	DPS10.1 and DPS10.2	15	2.2 - 5.7	0.9 - 3.6	1, 2
65	DPS10.1 and DPS10.2	24	2.7 - 6.5	1.2 - 4.9	1, 2
80	DPS10.1 and DPS10.2	36	4.3 - 10.7	2.1 - 7.4	1, 2, 3
100	DPS10.1 and DPS10.2	60	11.4 - 27.7	4.9 - 17.1	1, 2, 3
150	DPS10.1 and DPS10.2	120	35 - 81	9.7 - 34	1, 2, 3
200	DPS10.1 and DPS10.2	240	72 - 165	13.6 - 47.6	1, 2, 3
250-300	DPS10.1 and DPS10.2	360	156 - 290	25.7 - 90.1	1, 2, 3
25-300	DPS10.3	1 - 8 m/s air 1 bar			

## Technical Specifications:

**Max. pressure:** 11 bar brass, 30 bar stainl. steel

**Max. medium temp.:** 120°C (DPS10.3, 85°C)

**Max. ambient temp.:** 85°C

**Mounting position:** any

**Process connection:** DPS10.1 and DPS10.2: G1 A, DPS10.3: mounting plate

**Pressure loss:** 0.06 to 0.08 bar

**Hysteresis:** depends on switching value, at least 0.1 l/min

## Electrical data:

**Switching output:** microswitch, changeover contact, 250 VAC, 15 A (8 A inductive)

**Thread adapter:** PG11

**Protection type:** IP65

## Ordering code:

**Order number:**

**DPS10. 1. 1.**

**DPS10 Paddle-bellows type flow switch**

**Material combination:**

1 = Brass housing, stainless steel paddle for water

2 = Stainless steel housing, stainless steel paddle for water

3 = Brass housing, stainless steel paddle for air

**Adjustment range:**

1 = Standard

2 = Reduced

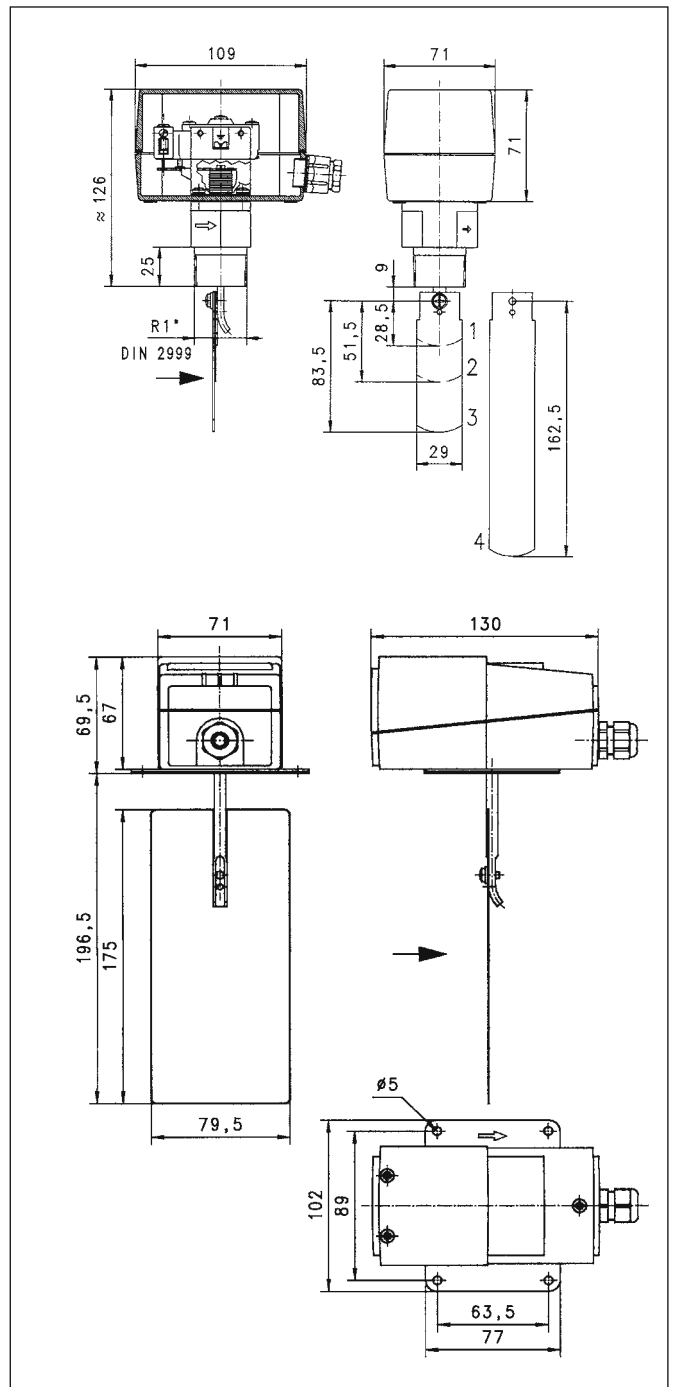

**PKP Prozessmesstechnik GmbH**   
Borsigstraße 24 · D-65205 Wiesbaden

+49 (0) 6122-7055-0 · +49 (0) 6122-7055-50  
Email: info@pkp.de · Internet: www.pkp.de

**PKP Process Instruments Inc.**   
10 Brent Drive · Hudson, MA 01749

+1-978-212-0006 · +1-978-568-0060  
Email: info@pkp.eu · Internet: www.pkp.eu

