



苏美自动化  
Sumei Automation



**Pompe ad ingranaggi**  
*Gear pumps*



**Distributori oleodinamici**  
*Directional control valves*



# Pompe ad ingranaggi Gear pumps



## POMPE GRUPPO PUMPS GROUP 1

Grandezza Size	Cilindrata Displacement [cm³/g] - (in³/rev)	Pressione massima continua Continuous max. pressure P1 [bar] - (PSI)	Pressione massima di picco Max. peak pressure P3 [bar] - (PSI)	Velocità max. Max. speed [g/min] - (rpm)	Portata max. Max. flow [l/min] - (Gal/min)	Rendimento volumetrico min. Min. volumetric efficiency %
1SP_0.9	0.89 (0.05)	240 (3480)	290 (4205)	6000	5.3 (1.40)	92*
1SP_1.2	1.18 (0.07)	240 (3480)	290 (4205)	6000	7.1 (1.88)	
1SP_1.6	1.6 (0.10)	240 (3480)	290 (4205)	6000	9.6 (2.54)	
1SP_2.0	2.0 (0.12)	220 (3190)	270 (3915)	5500	11 (2.91)	
1SP_2.5	2.5 (0.15)	220 (3190)	270 (3915)	5000	12.5 (3.30)	
1SP_3.2	3.2 (0.20)	210 (3045)	260 (3770)	4500	14.4 (3.80)	95*
1SP_3.7	3.7 (0.23)	210 (3045)	260 (3770)	4000	14.8 (3.91)	
1SP_4.2	4.2 (0.26)	190 (2755)	230 (3335)	3500	14.7 (3.88)	
1SP_5.0	5.0 (0.31)	180 (2610)	230 (3335)	3000	15 (3.96)	
1SP_6.3	6.3 (0.38)	170 (2465)	210 (3045)	2700	17 (4.49)	
1SP_7.8	7.76 (0.47)	170 (2465)	210 (3045)	2500	19.4 (5.13)	
1SP_9.8	9.78 (0.60)	150 (2175)	190 (2755)	2000	19.6 (5.18)	

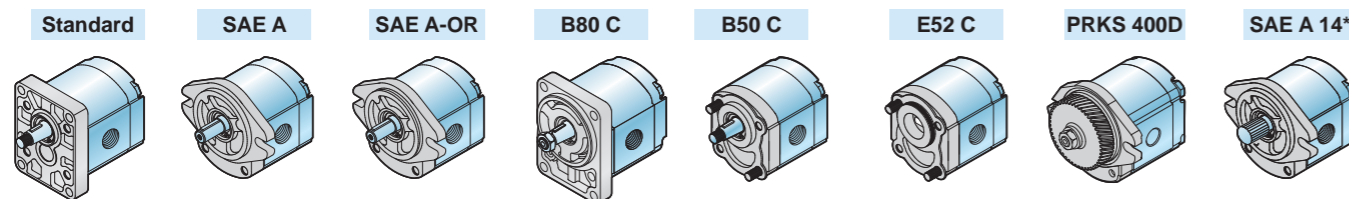

## POMPE GRUPPO PUMPS GROUP 2

Grandezza Size	Cilindrata Displacement [cm³/g] - (in³/rev)	Pressione massima continua Continuous max. pressure P1 [bar] - (PSI)	Pressione massima di picco Max. peak pressure P3 [bar] - (PSI)	Velocità max. Max. speed [g/min] - (rpm)	Portata max. Max. flow [l/min] - (Gal/min)	Rendimento volumetrico min. Min. volumetric efficiency %
2SP_4	4 (0.24)	280 (4060)	320 (4640)	4000	16 (4.23)	95*
2SP_6	6 (0.37)	280 (4060)	320 (4640)	4000	24 (6.34)	
2SP_8	8.5 (0.52)	280 (4060)	320 (4640)	3500	29.7 (7.85)	
2SP_11	11 (0.67)	280 (4060)	320 (4640)	3500	38.5 (10.17)	
2SP_14	14 (0.85)	270 (3915)	290 (4205)	3500	49 (12.95)	
2SP_16	16.5 (1.01)	230 (3335)	250 (3625)	3500	57.7 (15.24)	
2SP_19	19.5 (1.19)	210 (3045)	230 (3335)	3300	64.3 (16.99)	
2SP_22	22.5 (1.37)	190 (2755)	210 (3045)	2800	63 (16.64)	
2SP_26	26 (1.59)	170 (2465)	190 (2755)	2500	65 (17.17)	

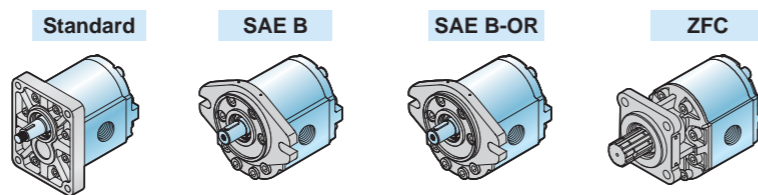

## POMPE GRUPPO PUMPS GROUP 3

Grandezza Size	Cilindrata Displacement [cm³/g] - (in³/rev)	Pressione massima continua Continuous max. pressure P1 [bar] - (PSI)	Pressione massima di picco Max. peak pressure P3 [bar] - (PSI)	Velocità max. Max. speed [g/min] - (rpm)	Portata max. Max. flow [l/min] - (Gal/min)	Rendimento volumetrico min. Min. volumetric efficiency %
3SP_19	19 (1.16)	270 (3915)	320 (4640)	3500	66.5 (17.57)	95*
3SP_22	22.3 (1.36)	260 (3770)	300 (4350)	3500	78 (20.61)	
3SP_29	29.3 (1.79)	240 (3480)	280 (4060)	3300	96.7 (25.55)	
3SP_33	32.9 (2.01)	240 (3480)	280 (4060)	3300	108.6 (28.69)	
3SP_36	36.4 (2.22)	230 (3335)	270 (3915)	3300	120.1 (31.73)	
3SP_44	43.5 (2.65)	200 (2900)	240 (3480)	3000	130.5 (34.48)	
3SP_52	51.7 (3.15)	200 (2900)	240 (3480)	3000	155.1 (40.98)	
3SP_62	61.1 (3.73)	180 (2610)	200 (2900)	2500	152.7 (40.34)	

(Valori rilevati in fase di collaudo a 1500 giri/min e alla pressione P1 / Value taken during the testing at 1500 rpm) and at P1 pressure

## DISTRIBUTORI MONOBLOCCO MONOBLOCK DIRECTIONAL CONTROL VALVES

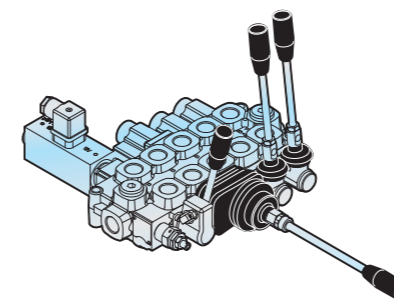

	Q35	Q25	Q45	Q75	Q95
Numero massimo di sezioni di lavoro Working section max number	1	8		6	3
Attacchi Ports	3/8" BSP (SAE 8)	3/8" BSP (SAE 8)	1/2" BSP (SAE 10)	1/2" BSP (SAE 10)	3/4" BSP (SAE 12)
Limiti temperatura olio Oil range temperature	-30 + 80 °C				
Temperatura olio consigliata Recommended oil temperature	30 + 60 °C				
Filtraggio consigliato Recommended filtering	26/23 ISO DIS 4406				
Fluido Hydraulic fluid	Olio minerale Mineral oil				
Viscosità [cst] Viscosity [cst]	10 + 400				
Portata massima consigliata [l/min] Max flow suggested [Gal/min]	50 (13.20)	45 (11.88)	60 (15.84)	90 (23.76)	120 (31.68)
Pressione max. d'esercizio [bar] Max. working pressure [PSI]	300 (4350)	350 (5075)	350 (5075)	350 (5075)	350 (5075)

## DISTRIBUTORI COMPONENTI SECTIONAL DIRECTIONAL CONTROL VALVES

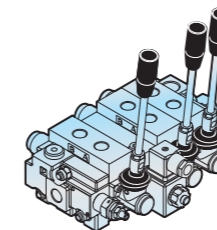

	Q30	Q50	Q80	Q130
Numero massimo di sezioni di lavoro Working section max number	10	10	10	10
Attacchi Ports	3/8" BSP (SAE 8)	1/2" BSP (SAE 10)	1/2" BSP (SAE 10)	3/4" BSP (SAE 12)
Limiti temperatura olio Oil range temperature	-30 + 80 °C			
Temperatura olio consigliata Recommended oil temperature	30 + 60 °C			
Filtraggio consigliato Recommended filtering	26/23 ISO DIS 4406			
Fluido Hydraulic fluid	Olio minerale Mineral oil			
Viscosità [cst] Viscosity [cst]	10 + 400			
Portata massima consigliata [l/min] Max flow suggested [Gal/min]	40 (10.56)	60 (15.84)	90 (23.76)	150 (39.60)
Pressione max. d'esercizio [bar] Max. working pressure [PSI]	375 (5438)			

Directional controls valves Distributori oleodinamici

## Pompe ad ingranaggi

Galtech è specializzata nella produzione di pompe dal gruppo 1 al gruppo 3 suddivise in 30 cilindrate da 0.9 a 52 cc, e fino a 320 bar di pressione massima di esercizio. Sono disponibili versioni con flange e coperchi in ghisa per ridurre il livello di rumorosità.

Ogni pompa può essere assemblata con totale intercambiabilità sia con flange standard (Europea, Tedesca, SAE) sia con quelle speciali (ZF, Perkins e Renault) e con alberi conici, cilindrici e scanalati.

È possibile inoltre montare coperchi con valvole limitatrici di pressione e valvole regolatrici di flusso.

Tutte le pompe sono predisposte per il traino posteriore di una o più pompe interponendo il kit di accoppiamento disponibile anche in versione corta e in versione per alta e bassa pressione.



## Gear pumps

Galtech is specialized in pumps production from group 1 to group 3, divided into 30 displacements: from 0.9 to 52 cc, and 320 bar max working pressure. Pumps are available with cast flange and cover versions to reduce the noise level.

Each pump can be assembled with standard flanges (European, German or SAE) or with special ones (ZF, Perkins and Renault), with tapered, cylindrical or splined shafts.

Furthermore, it is possible to assemble covers with pressure relief valves and flow control valves.

All standard pumps are arranged to accept one or more pumps using the coupling kits, available also in the short version and for high or low pressure.

## Distributori oleodinamici

I distributori Galtech vengono prodotti nelle versioni componibili e monoblocco con portata fino a 150 l/min e con pressione massima di esercizio fino a 380 bar.

Possono essere realizzati con circuito paralleli, tandem e serie.

Sono disponibili attacchi BSP da 1/4" a 1" e attacchi UNF da SAE 6 fino a SAE 16.

Tutti i nostri distributori sono caratterizzati da ingombri ridotti, basse perdite di carico e bassi trafileamenti interni.

Esistono vari tipi di comandi e posizionatori intercambiabili, differenti cursori con vari livelli di sensibilizzazione.

Su ogni distributore si ha la possibilità di applicare valvole ausiliarie per il controllo di pressione e portata.

Oltre ai distributori proporzionali da breve tempo sono entrati a fare parte della nostra famiglia i distributori load sensing.

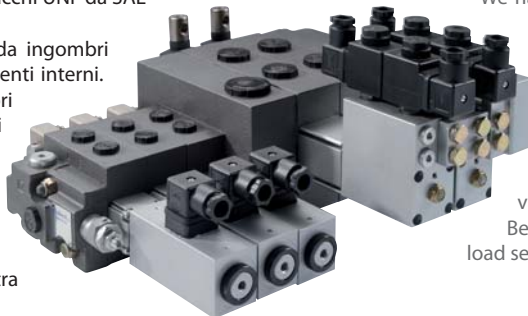

## Directional control valves

Directional control valves are manufactured in sectional and monoblock version, with capacity up to 350 l/min and with max working pressure up to 380 bar.

They can be produced with parallel, tandem and serie circuit.

We have available BSP threads from 1/4" to 1" and UNF threads from SAE 6 up to SAE 16.

Our valves have compact dimensions, low pressure drop and low internal leakage. We have several controls and positioning types, several spools with different sensitive levels.

To control pressure and capacity, auxiliary valve can be assembled on each directional control valve.

Besides proportionale valves, we have recently added load sensing capability to our valves range.



昆山苏美自动化科技有限公司

Kunshan Sumei Automation Technology Co.,LTD

TEL: (+86) 512-57910267 57914649 FAX: (+86) 512-82092939

Mail: kssumei@163.com Web: <http://www.smzdh.com>