

AIR TOOTH-TYPE CLUTCH

HTC形、BTC形

HTC形

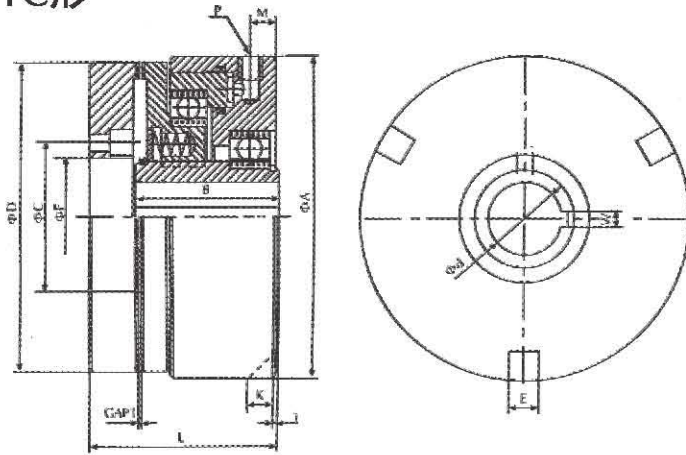

型号 (MODEL)	Torques(kgf.m) Air pressure 6kgf/cm ²	尺寸(DIMENSIONS)											d(Max)
		Clutch	A	B	C	D	E	F	K	L	M	P	
HTC-10	10	85	50	55	80	10	42	10	62	7	PT1/8	7	20
HTC-20	20	115	53	65	110	10	50	10	70	8	PT1/8	10	25
HTC-40	40	135	62	85	125	10	55	10	77	9	PT1/8	10	30
HTC-60	60	155	70	95	137	10	60	12	86	10	PT1/4	12	40
HTC-80	80	170	85	110	155	11	85	12	92	11	PT1/4	12	50
HTC-120	120	195	80	130	178	12	90	12	100	12	PT1/4	16	65
HTC-200	200	232	95	140	212	14	105	14	117	14	PT3/8	18	85
HTC-300	300	265	110	170	242	14	132	14	130	14	PT3/8	18	90

BTC形

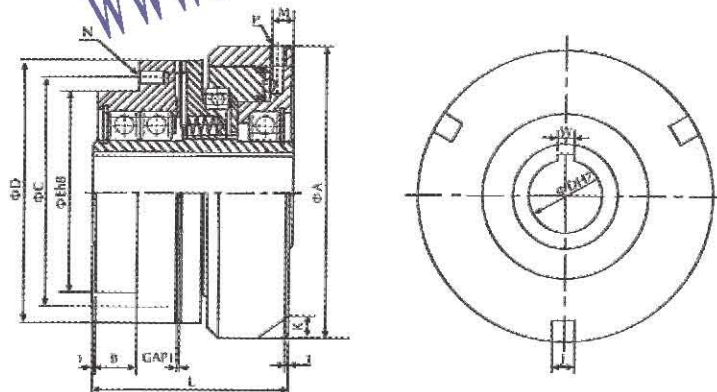

型号 (MODEL)	Torques(kgf.m) Air pressure 6kgf/cm ²	尺寸(DIMENSIONS)												d(Max)
		Clutch	A	B	C	D	E	J	K	L	M	N	P	
BTC-10	10	85	13	72	85	65	10	10	67	7	4XM6	PT1/8	7	20
BTC-20	20	115	18	90	110	75	10	10	80	8	4XM6	PT1/8	10	25
BTC-40	40	135	18	100	125	80	10	10	95	9	4XM8	PT1/8	10	30
BTC-60	60	155	20	115	137	90	12	12	105	10	6XM8	PT1/4	12	40
BTC-80	80	170	23	130	155	110	12	12	120	10	6XM8	PT1/4	12	50
BTC-120	120	195	23	150	178	130	12	12	125	10	6XM8	PT1/4	16	65
BTC-200	200	232	30	180	212	155	14	14	145	14	8XM8	PT3/8	18	85
BTC-300	300	265	30	205	242	180	14	14	180	14	8XM10	PT3/8	18	105