

The background features a dark blue field with several bright, glowing blue lines that intersect to form a network of triangles and polygons. The lines have a soft, ethereal glow. Faint, repeating watermarks are visible across the background, including the company name in Chinese characters and the website address.

sensL

Solutions for Nuclear Medicine

sensL: light detection and measurement

Mission

Working with our customers we identify, design and deliver low light detection solutions which solve customer problems and add value. We aim to be the partner of choice because of our flexibility, capabilities and the desire to meet our customer needs.

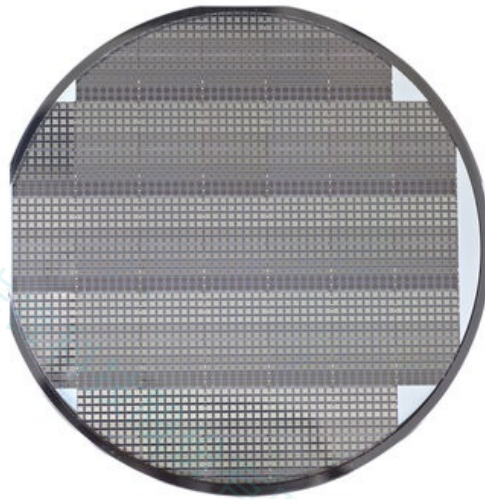

sensL

Motivation

...is to provide a lower cost and technology enabling solid-state alternative to the vacuum tube based photomultiplier tube (PMT)...

Solid State

Vacuum Tube



Plasma TV
(Bitzer/Gene Slottow)

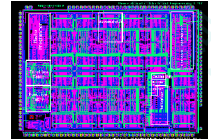

CMOS chip (174,569 transistors)



Silicon Transistor
(Texas Inst.)



LED (Holonyak)



sensL SPMArray

1875

1900

1925

1950

1975

2000



LightBulb
(Edison)

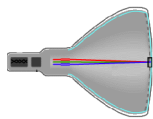

CRT
(Ferdinand Braun)



Vacuum Tube Diode
(Fleming)

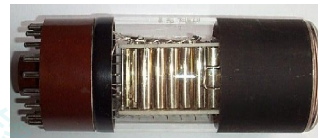

Photomultiplier Tube (RCA)



ENIAC (17,468 Tubes)

Introduction

- Silicon PhotoMultiplier (SPM) detectors are an exciting detector choice for nuclear medicine (PET & SPECT) of various modalities
- These high gain, low voltage, silicon detectors are ideally suited for coupling with scintillation crystals such as LYSO to form a scalable architecture for nuclear medical imaging
- sensL offer a full range of detectors and expertise to assist our customers in the adoption of SPM technology

sensL

SPM concept

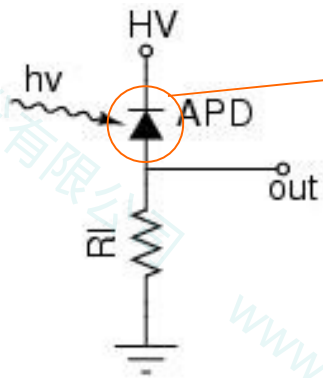

Geiger mode
Detector
A photon counting
diode detector
fabricated in
silicon forms the
basis for all sensL
products

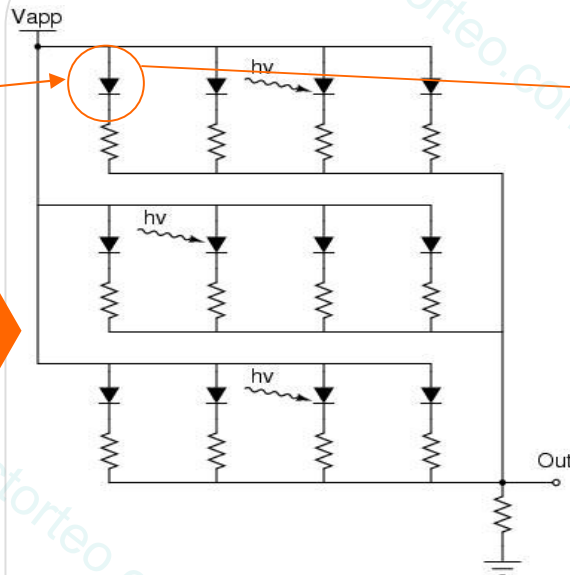

Silicon Photomultiplier
(SPM)
By fabricating large arrays
of photon counting
detectors, sensL create a
high gain detector to
replace the PMT

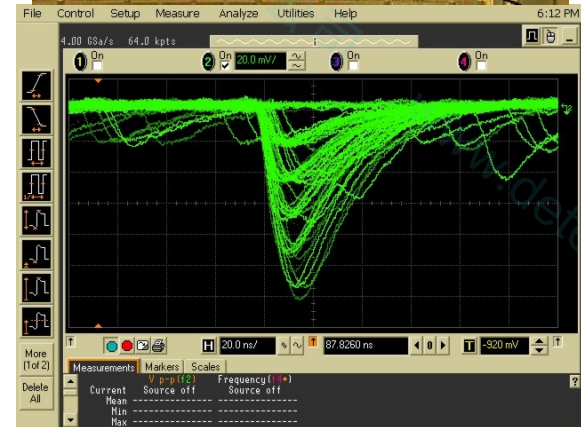
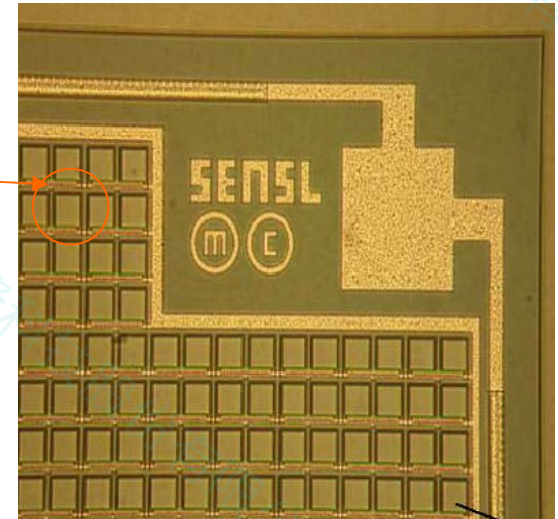

sensL

Where does an SPM come from?

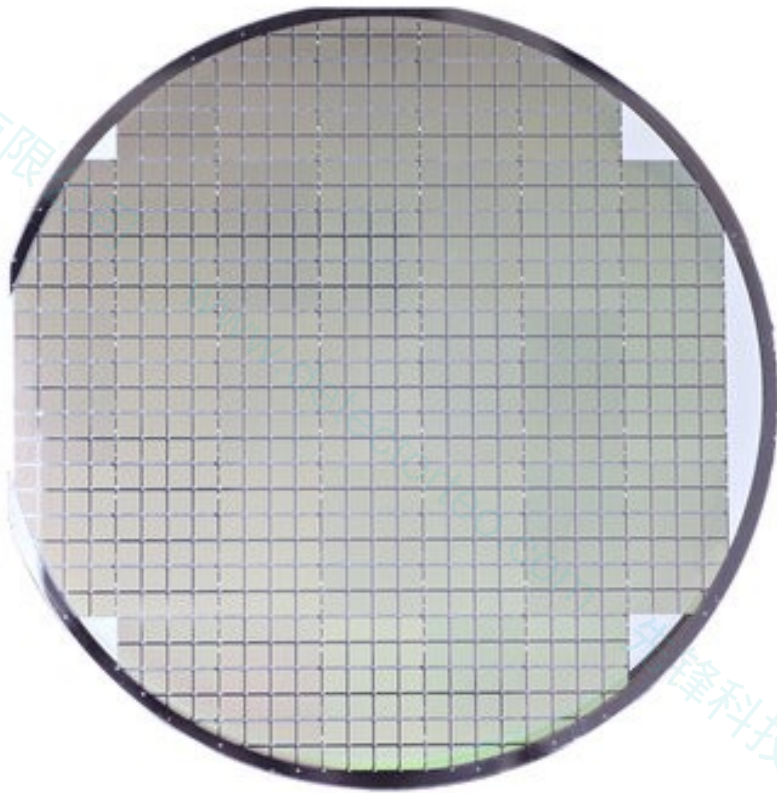

- sensL SPM detectors are bulk manufactured in a ISO9000 controlled semiconductor foundry
- sensL test and package to produce the best SPM products on the market

Why use SPM detectors?

- Compared to PMT detectors
 - Very small form factor
 - Rugged and immune to magnetic fields and vibrations
 - User safe voltages
 - Similar high gain
- Compared to PIN and APD detectors
 - Much higher gain – simpler system design
 - Much lower system cost and power
 - Less sensitive to bias and temperature change
 - Can operate at higher temperatures

SPM for nuclear medicine

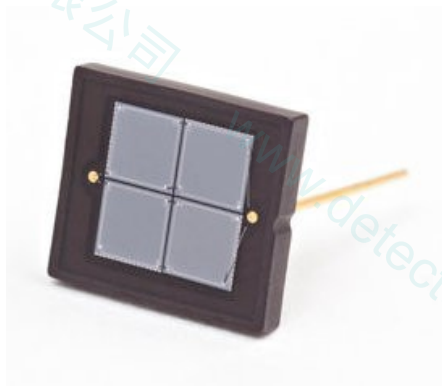

SPM detector in robust ceramic package



Crystal coupled directly to a sensL SPM

SPM detectors detect light from scintillating crystals

Combining a SPM detector with LYSO crystals for example, allows the 511keV photon from a PET scan to be detected

sensL

Nuclear Medicine Modalities

- PET/MRI
 - sensL provides the fullest range of MRI compatible detectors and electronics designed for operation in high Tesla MRI
- Full body PET
 - sensL provides low cost 4-side scalable technology
- Preclinical PET
 - sensL provides flexible pixel and packaging options
- Organ specific PET
 - sensL provides novel packaging and custom configurations
- In-vivo PET / Gamma Cameras
 - sensL is the leading supplier of low operating voltage SPM
- SPECT
 - sensL provides miniature detectors ideal for compact SPECT

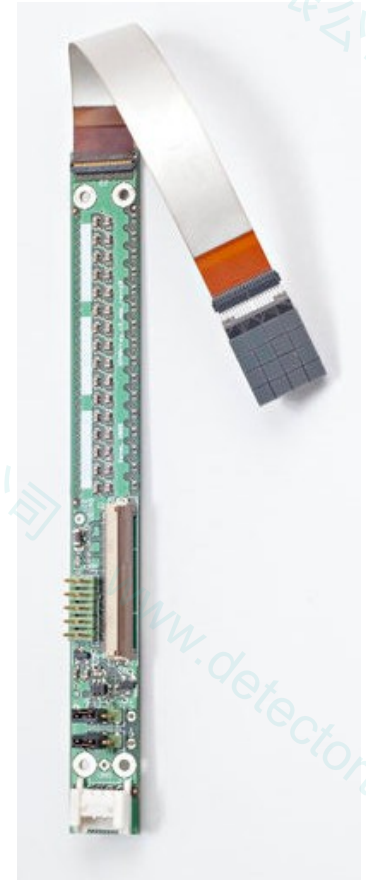

sensL

Building a PET module

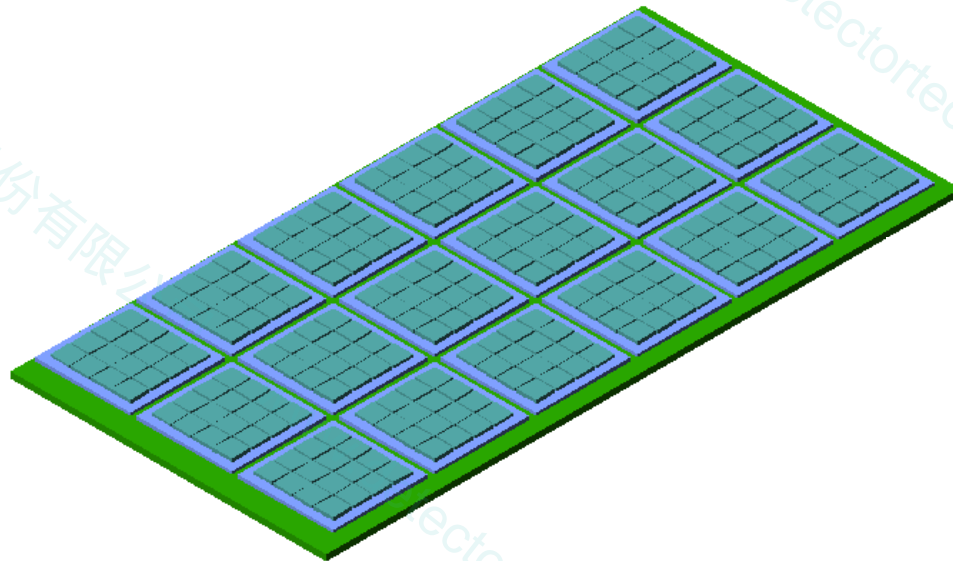

1) Arrays of SPM detectors can be mounted to cover a large field of view

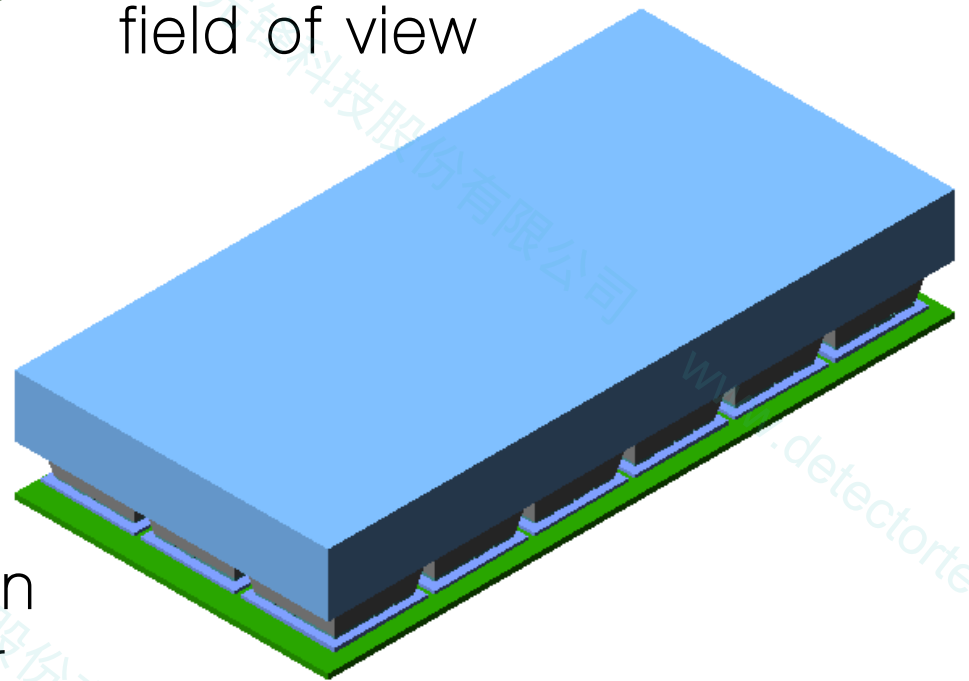

2) Coupling of the scintillation crystals to the SPM detector yields a compact detection head

PET full ring

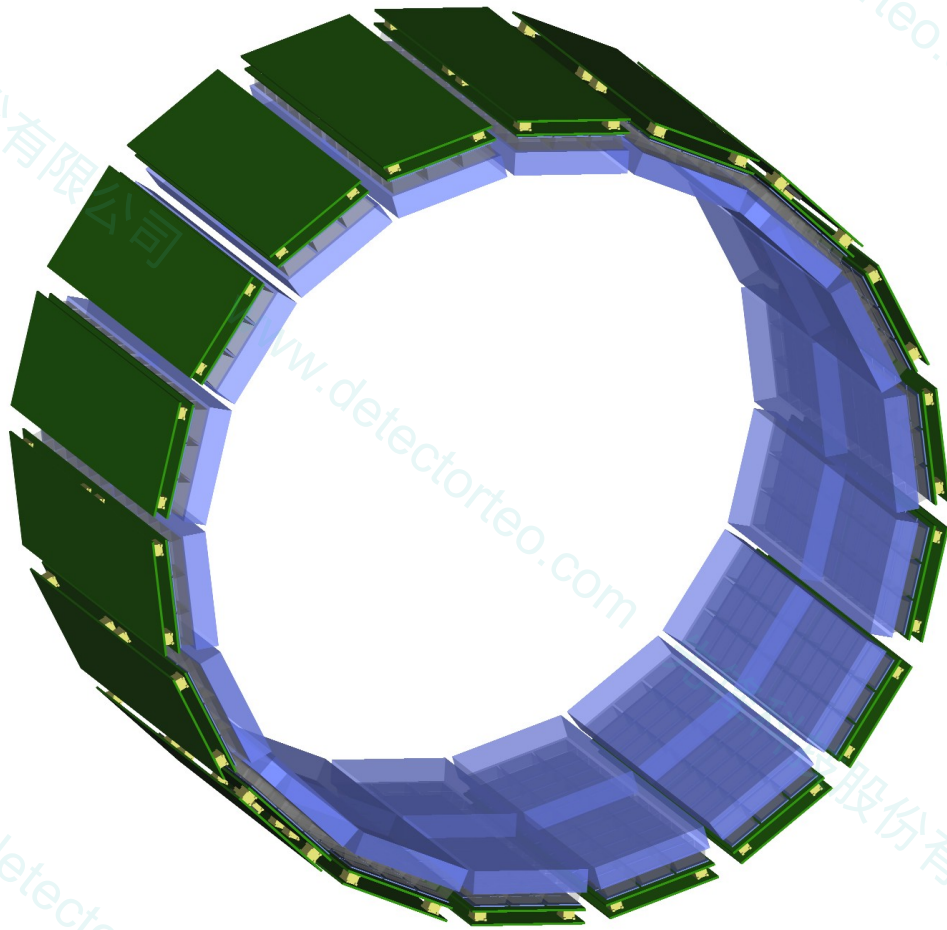

sensL's SPM provides:

- ✓ energy resolution
- ✓ spatial resolution
- ✓ timing
- ✓ high gain
- ✓ magnetic field operation

required by PET systems

sensL

Readout electronics

openPET

<http://openpet.lbl.gov/>

- For researchers
 - sensL are a founding member of the openPET readout architecture group
- For OEMs
 - sensL work directly with OEMs to provide a scalable fully digital system

sensL

Energy resolution

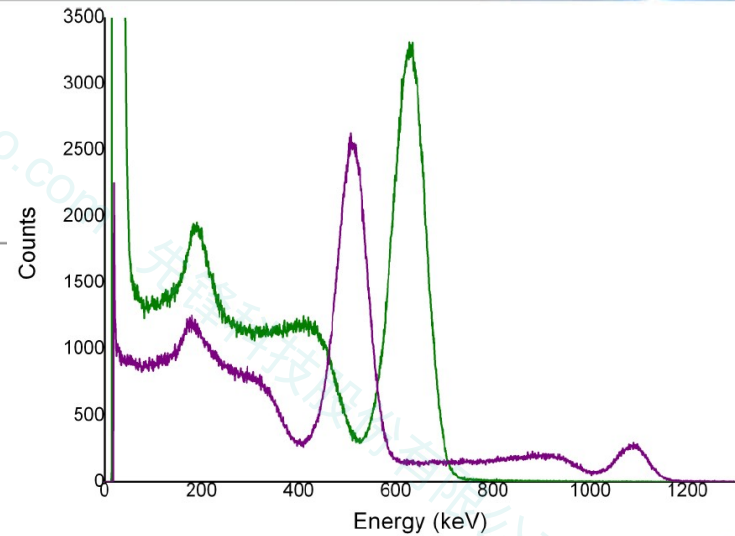
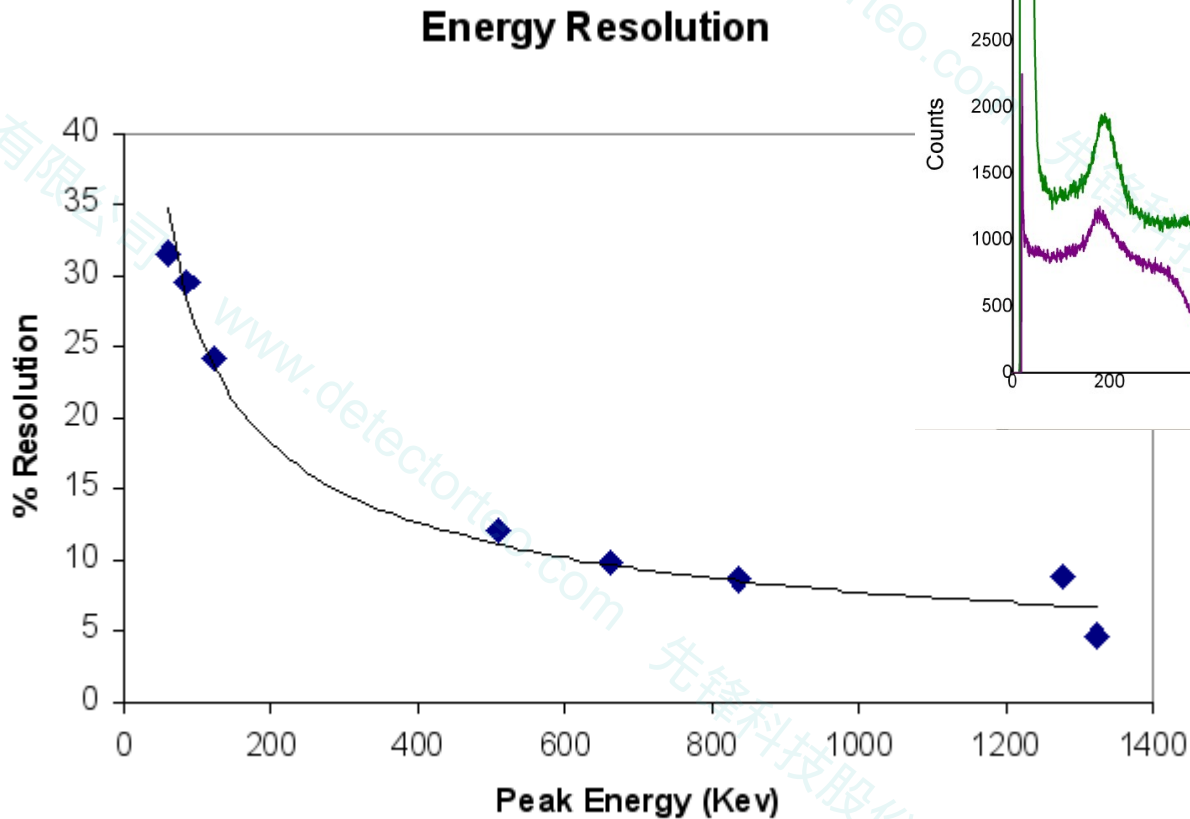

sensL SPM are ideal for detection of common high energy sources and particles

sensL

Temperature stability

Cs-137 Spectra Taken With Temperature Compensated Bias

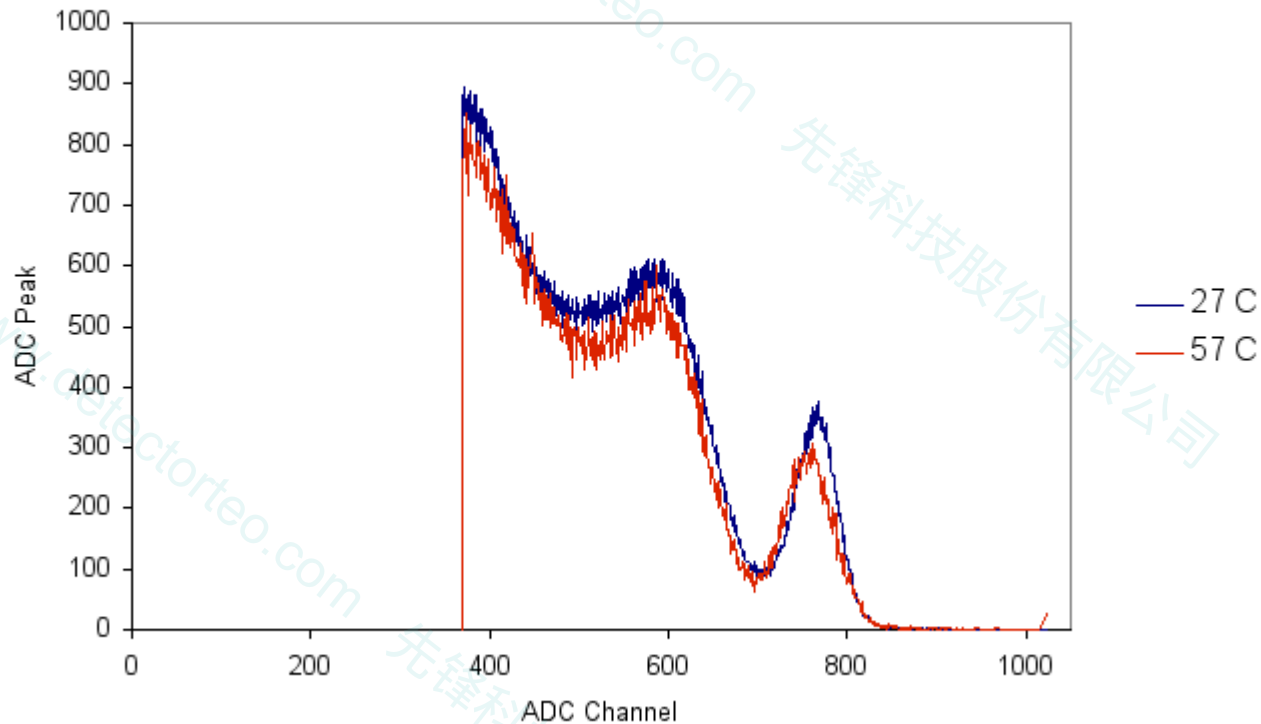

Operation can be stabilized over a wide temperature range

Linearity

Detection Linearity

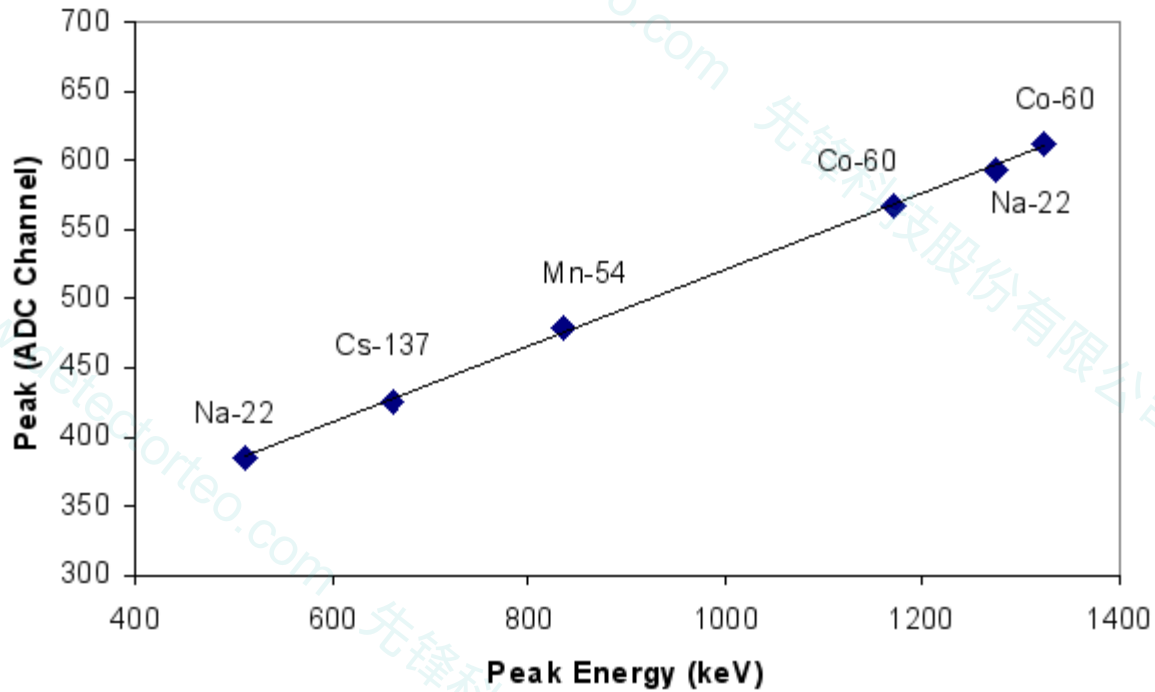

Linearity up to 3MeV

Timing resolution

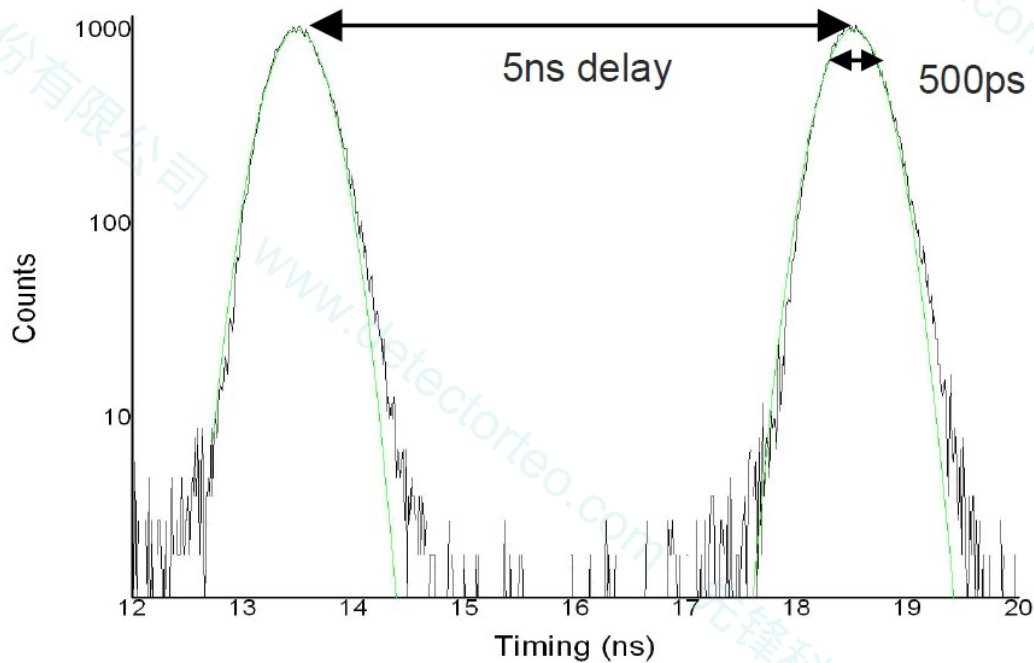

Coincidence resolving time (CRT) suitable for standard nuclear medical systems with sub nanosecond timing resolution

Products for nuclear medicine

Detector Products

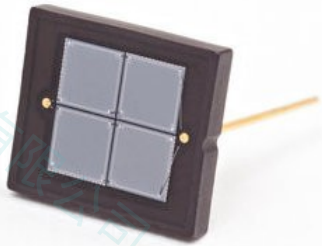

SPMMicro
1mm, 3mm & 6mm



SPMArray2 (glass)
3-side scalable
16 element detector



SPMArray4 (ceramic)
4-side scalable
16 element detector

Evaluation Kits

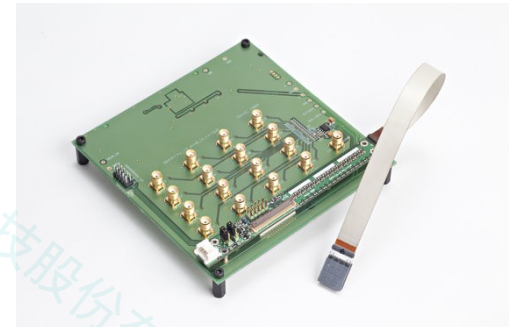

SPMArray Eval Board



ScintPack1

sensL

SPMMicro

Features



- 1mm, 3mm, 6mm diameter
- 35um, 50um, 100um microcell size
- Low voltage operation ($\sim 30V$)
- Unmatched breakdown voltage uniformity
- Ceramic package with epoxy coating
- Optional amplifier board with power supply for system test and prototyping
- Designed for miniaturized systems and for initial testing of SPM technology at the pixel level

SPMArray2 (glass)

Features

- 3-side scalable design
- 16 channels
- Ideal for depth of interaction
 - subject side mounting possible
- MRI compatible
- Cable lengths up to 3m
- 16 channel preamplifier option
- evaluation board option
- Ideal for depth of interaction and space critical applications

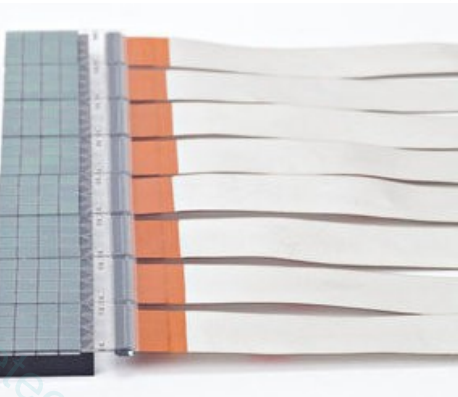
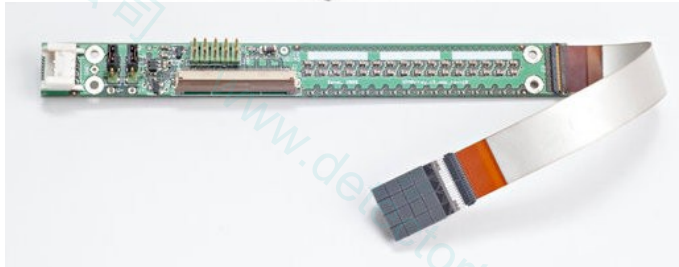

SPMArray4 (ceramic)

Features

- 4-side scalable design
- 16 channels – single power supply
- Ceramic package with epoxy coating
- Designed for simultaneous MRI compatibility to 3 Tesla
- 16 channel preamplifier option
- Evaluation board option
- Designed for large area scalable applications

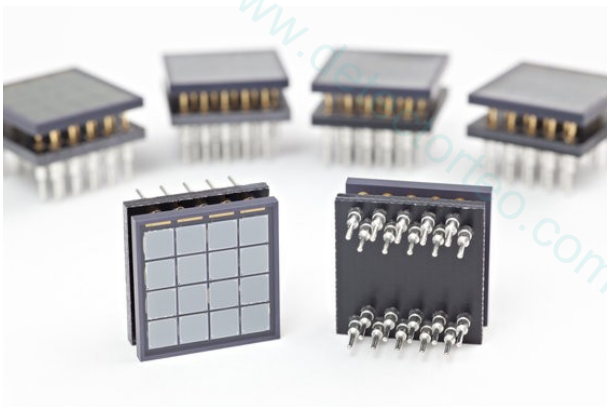

ScintPack1

Features

- 3mm and 6mm SPM detectors
- LYSO, BGO and CsI(Tl) crystal samples
- Mounting grease in syringe
- Amplifier board with power supply
- Instruction manual
- Allows the user to get up to speed and rapid prototype with sensL SPM technology



Conclusions

- sensL provide the most comprehensive SPM portfolio on the market
- sensL's SPM detectors are ideal for OEM and research nuclear medicine systems where users require performance, flexibility and manufacturability
- Benefits to our customers: uniformity, low volume system cost, high performance, robustness, reliability, low operating voltages, high volume and scalable technology