

ABSOLUTE MAXIMUM RATINGS:

Supply Voltage	-0.3 to 10V
Maximum Voltage other pins	-0.3 to $V_{CC}+0.3V$
Power Dissipation	450mW
Operating Temperature	-40 to 85 °C
Storage Temperature	-55 to 150°C

ELECTRICAL CHARACTERISTICS:

Test conditions unless otherwise stated: $V_{CC}=1.5V$, $T_{AMB}=25^{\circ}C$

Symbol	Parameter	Conditions	Min	Typ	Max	Units
η	Efficiency ¹				94	%
V_{CC}	Recommended supply voltage range		0.8		8	V
$V_{CC(min)}$	Minimum startup and operating voltage	$I_{DRIVE}=-600\mu A$, $V_{DRIVE}=0.7V$ $I_{DRIVE}=-600\mu A$, $V_{DRIVE}=0.7V$, $T_{AMB}=-10^{\circ}C^3$		0.8 0.9	0.92	V
I_Q	Quiescent current ²	$V_{EN} = V_{CC}$ (enabled) $V_{EN} = 0V$ (standby)		0.2 5	10	mA μA
I_{VDRIVE}	Base drive current	$V_{DRIVE} = 0.7V$, $V_{ISENSE} = 0V$	1.5		3.5	mA
I_{CC}	Supply current ³	$V_{DRIVE} = 0.7V$, $V_{ISENSE} = 0V$	2		4	mA
$V_{VDRIVE(high)}$	High level drive voltage	$V_{ISENSE} = 0V$, $I_{VDRIVE} = -0.5mA$	V_{CC} -0.3		V_{CC}	V
$V_{VDRIVE(low)}$	Low level drive voltage	$V_{ISENSE} = 50mV$, $I_{VDRIVE} = 5mA$	0		0.2	V
$V_{STDN(high)}$	Device enabled		0.7			V
$V_{STDN(low)}$	Device in standby mode				0.15	V
I_{STDN}	Enable input current		-1		1	μA
V_{ISENSE} (threshold)	Output current reference voltage		14	19	24	mV
$T_{CVISENSE}$	I_{SENSE} voltage temp co. ²			0.4		%/°C
I_{ISENSE}	I_{SENSE} input current	$V_{ISENSE} = 0V$	0	-30	-65	μA
T_{DRV}	Discharge Pulse Width		1.2	1.7	3.2	μs

OPERATING CONDITIONS

Symbol	Parameter	Conditions	Min	Typ	Max	Units
F_{OSC}	Recommended operating frequency ⁴				200	kHz

1 Application dependent, see reference designs

2 These parameters guaranteed by Design and characteristics

3 Total supply current = $I_Q + I_{VDRIVE}$, see typical characteristics

4 Operating frequency is application circuit dependent. See applications section.

TYPICAL CHARACTERISTICS

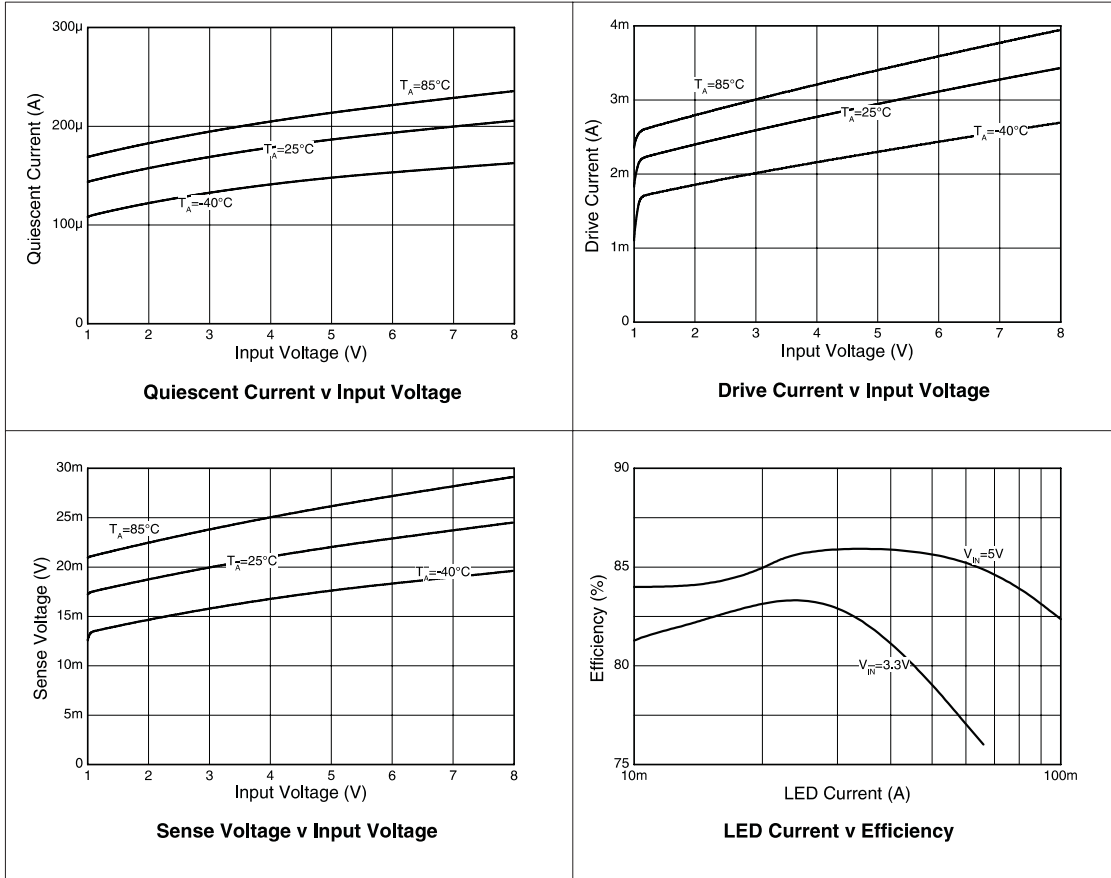

REFERENCE DESIGNS

Three typical LED driving applications are shown. Firstly a typical LCD backlight circuit, then maximum brightness LED driving solution and lastly an optimised battery life LED driving solution.

LCD backlight circuit

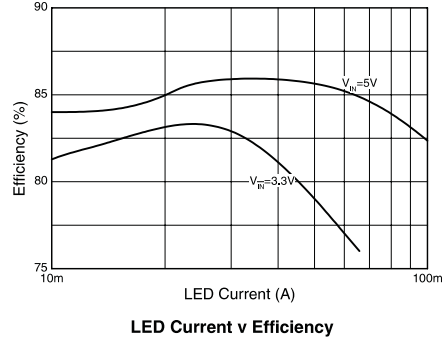
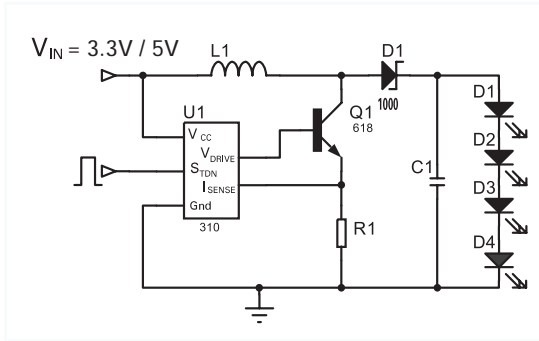

(Notes)

This application shows the 310 in a typical LCD backlight application for Digital Still Cameras and PDA's. The input voltage for these backlight circuits are usually fixed from the main system power, typically 3.3V or 5V. The LED's are connected serially so that the light is distributed uniformly in each LED. The current provided to the LED's can either be pulsed or DC. The DC current is programmable via a sense resistor, RSENSE, and is set to an optimum LED current of 20mA for the reference designs. DC current is achieved by adding a Schottky rectifying diode and an output capacitor, as shown in the reference design below.

Materials list

Ref	Value	Part Number	Manufacture	Comments
U1	N/A	310	PIC	SOT23-5
Q1	N/A	618	PIC	Low V _{CE(sat)} NPN, SOT23
D1	N/A	1000	PIC	1A Schottky diode, SOT23
C1	2.2 μF	Generic	Various	0805 Size
R1 ⁶	150m Ω	Generic	Various	1206 Size
R1 ⁷	250m Ω	Generic	Various	1206 Size
L1 ⁸	68μH			Surface mount inductor

⁶Used for 3.3V input, I_{LED} set to 20mA ±10%.
⁷Used for 5V input, I_{LED} to 20mA ±10%.
⁸See Application section.

Peak current definition

The peak current rating is a design parameter whose value is dependent upon the overall application. For the high brightness reference designs, a peak current of was chosen to ensure that the converter could provide the required output power to the LED.

In general, the I_{PK} value must be chosen to ensure that the switching transistor, Q1, is in full saturation with maximum output power conditions, assuming worse-case input voltage and transistor gain under all operating temperature extremes.

Once I_{PK} is decided the value of R_{SENSE} can be determined by:

$$R_{SENSE} = \frac{V_{ISENSE}}{I_{PK}}$$

A selection guide of sense resistor and inductor values for given input voltages, output currents and number of LED connected in series is provided in the table below.

Input Voltage (V)	LED current (mA)	No. of LED's	R_{SENSE} (m Ω)	Inductor (μ H)	Efficiency (%)
3.3V	10	3	510	68	80
3.3V	10	4	330	68	81
3.3V	10	6	150	68	79
3.3V	20	3	220	68	84
3.3V	20	4	150	68	93
3.3V	20	6	77	68	79
3.3V	30	3	170	68	84
3.3V	30	4	100	68	84
3.3V	30	6	47	68	77
5V	10	3	750	68	83
5V	10	4	510	68	84
5V	10	6	330	68	79
5V	20	3	440	68	85
5V	20	4	250	68	85
5V	20	6	150	68	82
5V	30	3	330	68	86
5V	30	4	170	68	85
5V	30	6	100	68	83

Shutdown Control

The 310 offers a shutdown mode that produces a standby current of less than 5uA when in operation. When the voltage at the S_{TDN} pin is 0.7V or higher the 310 is enabled, hence the driver is in normal operation. When the voltage at the S_{TDN} pin is 0.1V or lower the 310 is disabled, hence the driver is in shutdown mode. If the S_{TDN} pin is open circuit the 310 is also enabled.

Demonstration board

A demonstration board for the LCD backlighting solution, is available upon request. These can be obtained through your local office or through web pages. For all reference designs Gerber files and bill of materials can be supplied.

Layout of LCD backlighting solution

Top Silk

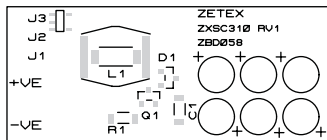

Drill File

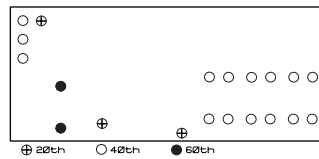

Top Copper



Bottom Copper



PINOUT DIAGRAM

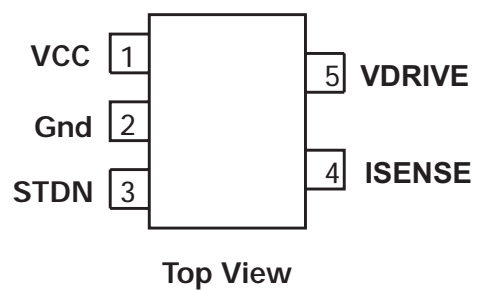

PIN DESCRIPTIONS

Pin No.	Name	Description
1	V_{CC}	Supply voltage, generally Alkaline, NiMH or NiCd single cell
2	G_{nd}	Ground
3	S_{TDN}	Shutdown
4	I_{SENSE}	Inductor current sense input. Internal threshold voltage set to 19mV. Connect external sense resistor
5	V_{DRIVE}	Drive output for external switching transistor. Connect to base of external switching transistor.