

The density transducer catalogue



mobrey

EMERSON
Process Management

On-line liquid density measurement solutions...

The field proven range of Solartron densitometers have been designed to meet the most demanding applications found in modern processing plants. These meters have long been recognised as the industry standard.

All Solartron densitometers are available with a choice of flange and material of construction. This allows them to be used in a broad range of process liquids ensuring that Solartron has the answer to your metering and control requirements.

The densitometers can either be supplied with a frequency output for connection to a signal converter/flow computer or direct 4-20mA outputs.

Fiscal metering

The 7835 is designed for fiscal metering of crude and refined hydrocarbons and non-corrosive process liquids. This transducer offers the highest accuracy with excellent repeatability under pipeline operating conditions. The vibrating element is manufactured from Ni-Span-C for excellent long term and temperature stability.

General process

Suitable for most general process applications, the 7845 is manufactured with all wetted parts in AISI 316L stainless steel.

Corrosive applications

For corrosive applications where AISI 316L stainless steel is not suitable, the 7846 is available with wetted parts in Hastelloy C22.

Hygienic applications

Solartron densitometers are widely used in the food industry for the monitoring and control of foodstuffs, for example, milk and yoghurt. The 3A authorised, all stainless steel 7847 with special bellows make it an ideal solution. Various sanitary fittings are available for the transducer.

Pipelines and static tanks

The 7826/8 Insertion densitometer has been developed for applications requiring liquid density measurement in pipelines or static tanks.

For static tanks, sensors of up to four metres in length can be supplied. The 7826/8 consists of a tuning fork arrangement with the tines mounted from a flange, which in turn supports the electronics housing.

Typical industries

- ▶ Oil and petrochemical
- ▶ Brewing
- ▶ Food
- ▶ Pharmaceutical
- ▶ Mineral processing (clays, carbonates etc.)



Principles of operation

All Solartron liquid density transducers operate on the same general principle and can be likened to that of a mass spring system. When a mass on a spring is displaced and released it will oscillate at a natural frequency until it comes to a rest due to viscous damping. When a driving force is applied to the mass to overcome the effect of damping, the vibration is maintained in resonance. As the measured product density changes, it in turn changes the vibrating mass of the density transducer, which is then detected by a change in the resonant frequency.

Calibration ... approving the best

Density calibration of the 7835 Series is carried out on three fluids: air, oil and a high density fluid. Initially the units are pressure tested to 1.5 times the operating pressure. With oil the rig is first varied in temperature to determine the temperature coefficient of the transducer and then varied in pressure to determine the pressure coefficient. To ensure that the production units are accurately calibrated to a high integrity, the calibration rigs have two integral transfer standards. The density readings from these standards must agree within certain limits, thus ensuring that the rig has stabilised. Once stabilisation is achieved, readings of periodic time from each of the production units can be taken on oil and the high density fluid. From these results and with results from an air calibration, the final calibration of the transducer is calculated. Typically, calibration takes up to two and a half days.

The gas density and tuning fork densitometers are calibrated slightly differently from the 7835 Series, but all calibrations use transfer standards calibrated in our UKAS laboratory.

UKAS accredited since 1981 the lab. employs two accredited metrologists and four trained calibration engineers.

Only Mobrey Measurement can offer UKAS calibration of density meters. We offer specialised, custom calibrations on request.

By maintaining this facility all our density calibrations are traceable to the UK National Physical Laboratory.

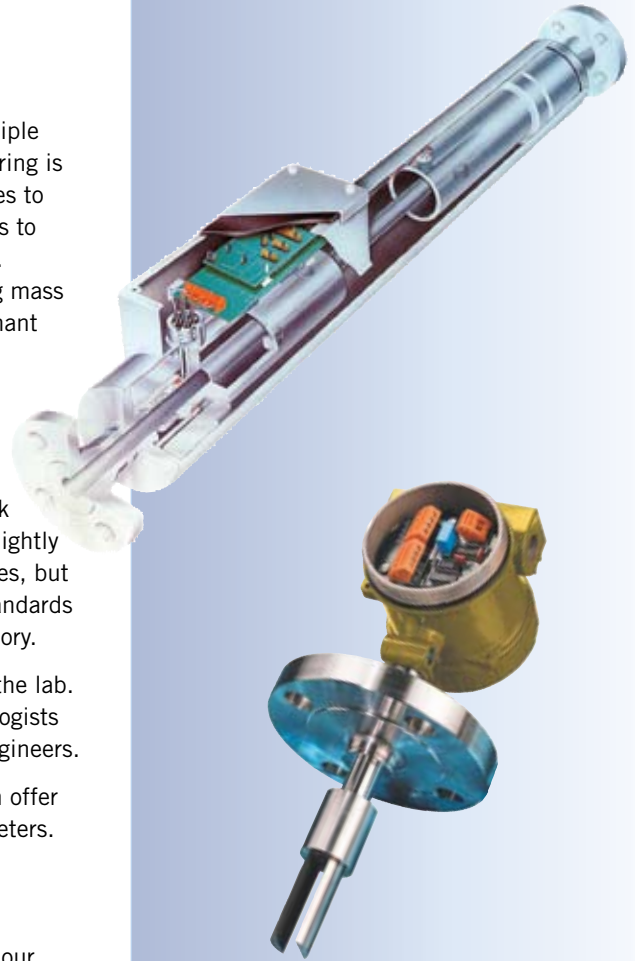

0099





Density tubes

The Solartron range of densitometers has been designed to tackle the most demanding of applications found in fiscal metering of crude oil and refined hydrocarbons. Other applications in the general process markets include % fat content of milk and % alcohol of whisky.

They offer the highest accuracy and repeatability under pipeline operating conditions.

Features

Insenitive to mounting position, plant vibration, flow rate and pressure

Intrinsically safe design

Straight through flow path

Pipeline quality: all welded construction

Continuous high accuracy measurement

Integral PT100 temperature sensor

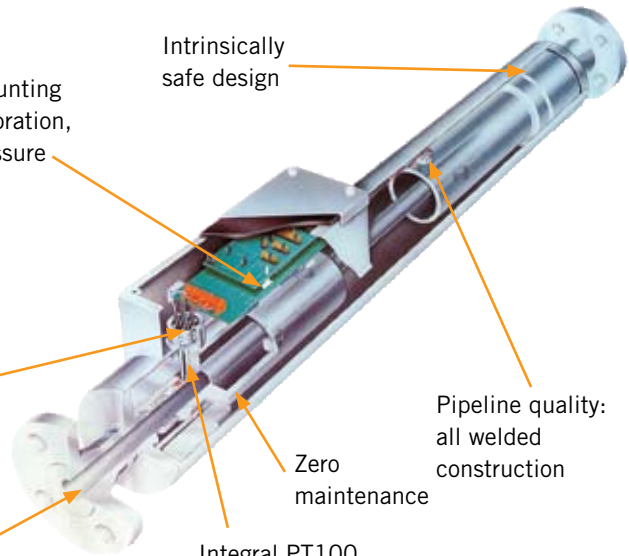

Functionality

All Solartron liquid density transducers measure two prime parameters, line density and temperature. From these two prime measurements a number of calculations can be performed, for example:

- ▶ Referred density (matrix & API)
- ▶ °API
- ▶ % Mass
- ▶ % Volume
- ▶ °Brix
- ▶ °Baume
- ▶ Specific gravity

Options

The 7835 Series densitometers can be supplied with a wide range of options from different flange connections to different electronic modules. This allows the end user to select the right option for their application at the best price.

The electronic options include:-

- ▶ Simple frequency output for connection to a flow computer or signal converter
- ▶ Advanced board which gives 2 x 4-20mA outputs with option for a 3rd analogue output
- ▶ HART communications
- ▶ Field mounted remote display
- ▶ Entrained gas version – this option is designed to permit the 7835 Series densitometer to measure the density of liquids with entrained air/gas such as ice-cream, yoghurt etc.

In addition to stand-alone densitometers, Mobrey Measurement can offer skid mounted densitometers. These are individually designed to client's requirements.



Insertion density

The 7826 and 7828 insertion liquid density transducers have been developed for applications requiring liquid density measurement in pipelines or in open or closed tanks. The 7828 features "on-node" configured microprocessor based electronics which place the full signal conditioning, calculation and diagnostic facilities within the transmitter itself. The 7826 requires remote electronics for signal processing.

Features

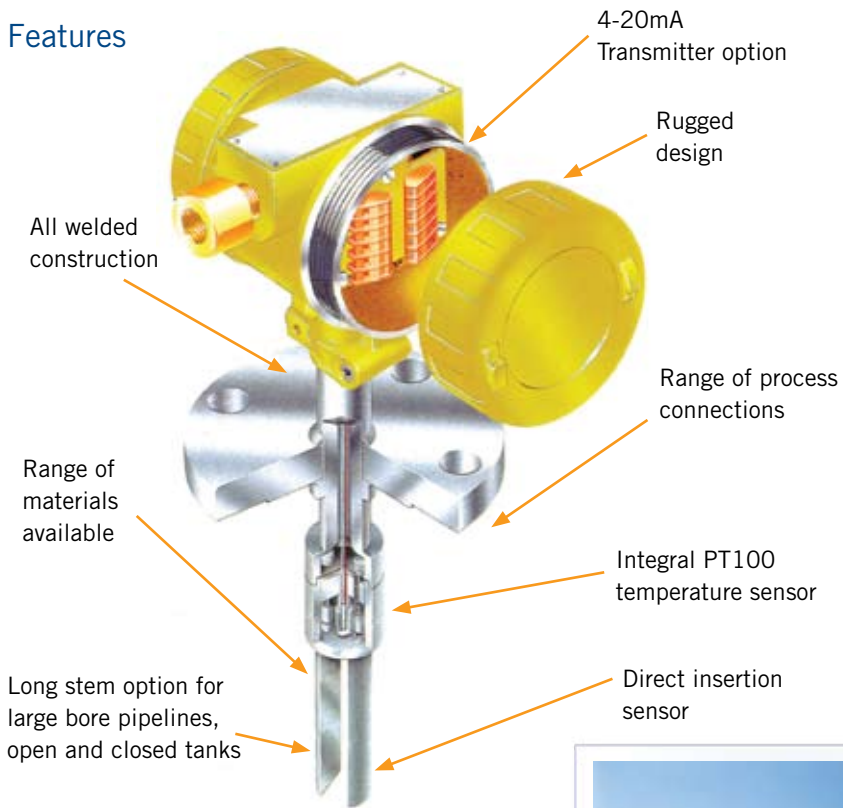

Applications

- ▶ Interface detection in multi-product pipelines
- ▶ Mass flow when used in conjunction with a volumetric flow meter
- ▶ Sugar refining (°Brix)
- ▶ Wort gravity
- ▶ Slurries
- ▶ Coatings
- ▶ Evaporator control
- ▶ Product mixing
- ▶ End point detection in batch reactions
- ▶ Solvent separation

Installation

Mobrey Measurement can provide a variety of installation accessories such as weldolets for direct pipeline insertion, or flow-through chambers.



Gas density and specific gravity products

Solartron gas density meters have been serving the hydrocarbon industry in custody transfer of natural gas for over three decades. The 7812 and 3098 transducers bring you all the benefits of highly accurate, continuous on-line measurements of gas density and gas specific gravity.

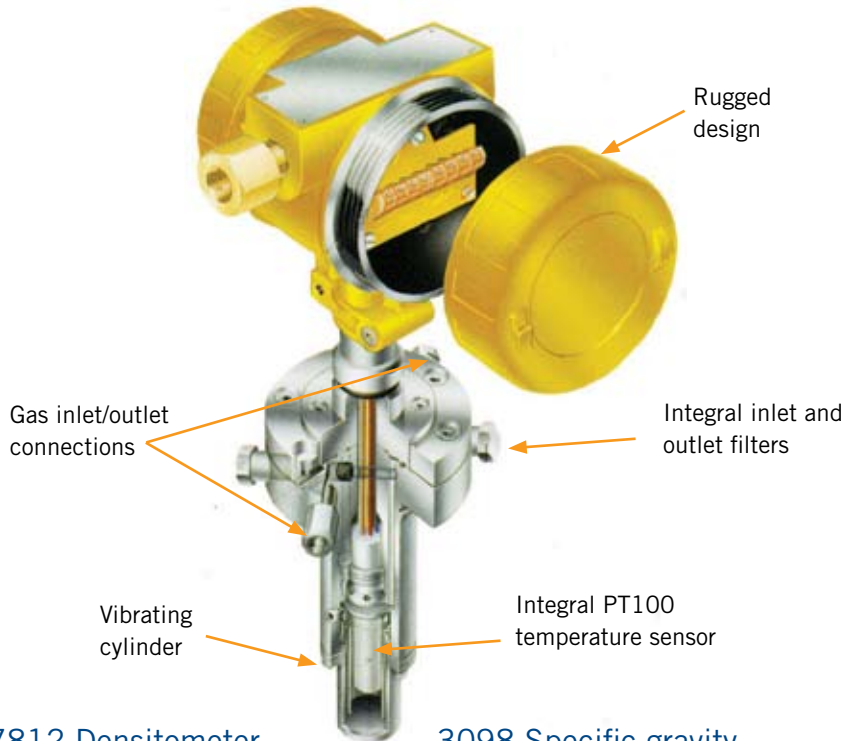

7812 Densitometer

The Solartron 7812 gas density transducer is designed to meet the requirements of custody transfer metering stations by combining high performance with safety. The sensor is designed for insertion mounting into the gas flow path, either directly or in a thermowell pocket, but with the gas sample brought to the instrument via a sample loop. This instrument satisfies the requirements of on-line density measurement as in ISO 5167 and AGA 3. The pressure retaining parts of the 7812 gas density transducer are manufactured for NACE compatible materials.

3098 Specific gravity transducer

The Solartron 3098 gas specific gravity transducer provides a direct on-line measurement of gas specific gravity or normal density for custody transfer, standard volume flow determination, quality analysis and energy management. The 3098 is most frequently applied in deriving standard volume and energy flow measurements of natural gas, where its exceptional accuracy and repeatability are of direct benefit.

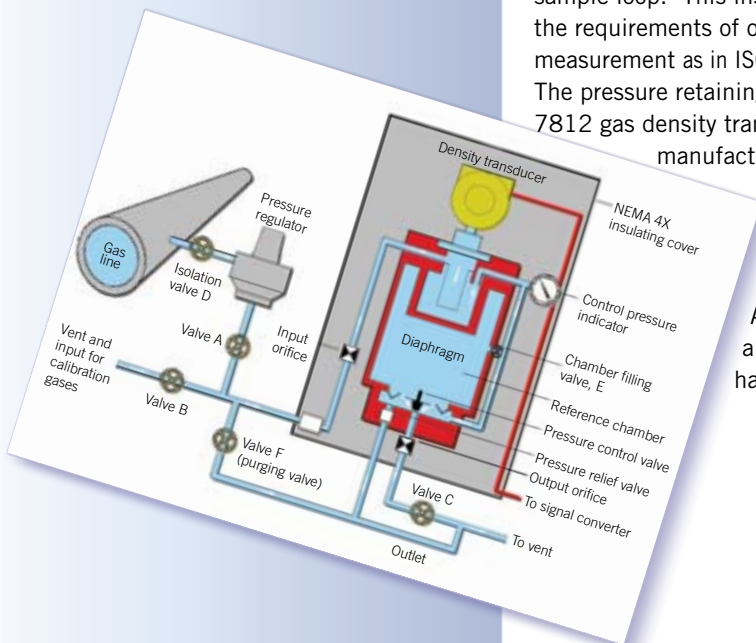

The transducer is approved by ATEX for use in all categories of hazardous area.

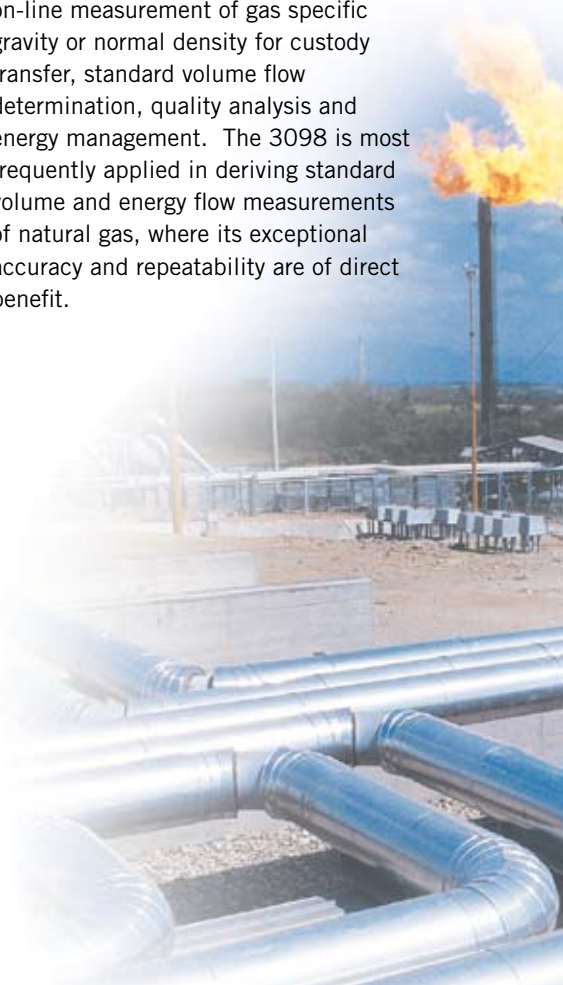

Signal converters

Solartron's 795x family of signal converters are the perfect complement for all our frequency output density transducers, enabling the engineer to create highly flexible measurement systems which are accurate, easy to set up and use, and interface simply with process and plant systems.

They are easy-to-use units which will process signals from Solartron density transducers along with live inputs of temperature and pressure. Calculations within the converter include transducer correction and calculation of line or referred density, specific gravity, °API, °Baume, calorific value, Wobbe Index etc. They boast a unique architecture, based on standard hardware.

Features

- High integrity and reliability
 - Maximum flexibility
 - Interchangeable platforms
 - Greater cost efficiency
 - Optimised user interface
 - Easier communications
- Typical 795x calculations:
- Line density
 - Referred density
 - Specific gravity
 - % Concentration



ADView diagnostic tool

Windows based ADView allows the transmitter series of densitometers to be configured using the RS485 communications if desired. For example, the user can change the span and bias of the 4-20mA output.

ADView also provides full diagnostic access to all measured and calculated parameters, and allows the storage of the unique sensor configuration to disc.

Data logging of parameters is also possible including logging several density transmitters linked together by multi-drop communications.

Download from www.solartronmobrey.com/downloads

ADView is installed on a PC and interacts with the density transmitters through one of the PC's standard serial (RS-232) ports.

ADView provides many useful facilities, such as:

- Setting up serial link to communicate with the density transmitter
- Configuring the density transmitter
- Displaying data in real time, or as a graph
- Logging data to a file
- Verifying correct operation of the system, and diagnosing faults
- Loading or storing Modbus register values
- Read/write to individual Modbus registers

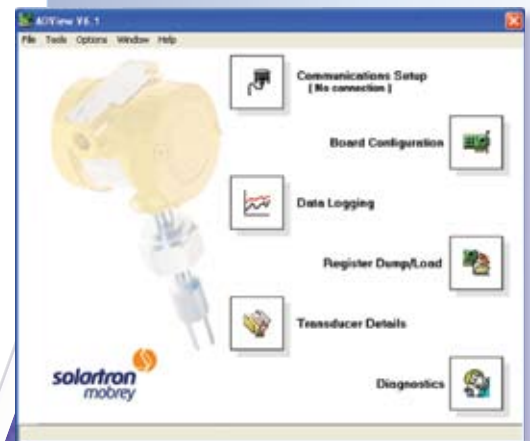

Mobrey Measurement has a worldwide network of distributors in 66 countries:



Abu Dhabi	China	Germany	Ireland	Mexico	Poland	Taiwan
Argentina	Colombia	Ghana	Italy	Morocco	Portugal	Thailand
Australia	Croatia	Greece	Japan	Myanmar	Qatar	Turkey
Austria	Cyprus	Holland	Jordan	New Zealand	Russia	UAE
Bahrain	Czech	Hong Kong	Kenya	Nigeria	Saudi Arabia	USA
Belgium	Denmark	Hungary	Korea	Norway	Singapore	Venezuela
Bolivia	Dubai	Iceland	Kuwait	Oman	South Africa	West Indies
Brazil	Egypt	India	Malawi	Pakistan	Spain	Zimbabwe
Canada	Finland	Indonesia	Malaysia	Peru	Sweden	
Chile	France	Iran	Mauritius	Philippines	Switzerland	

Mobrey Measurement
 158 Edinburgh Avenue, Slough,
 Berks UK SL1 4UE
 Tel: +44 (0)1753 756600
 Fax: +44 (0)1753 823589
 e-mail: mobrey.sales@
 EmersonProcess.com
 www.mobrey.com

Mobrey Inc.
 19408 Park Row, Suite 320,
 Houston, TX 77084 USA
 Tel: 281 398 7890
 Fax: 281 398 7891
 e-mail: mobrey.sales@
 EmersonProcess.com
 www.mobrey.com

Mobrey GmbH	Deutschland	tel: 0211/99 808-0
Mobrey Ltd	China	tel: 021 5443 8765
Mobrey sp z o o	Polska	tel: 022 871 7865
Mobrey AB	Sverige	tel: 08-725 01 00
Mobrey SA	France	tel: 01 30 17 40 80
Mobrey SA-NV	Belgium	tel: 02/465 3879



The right is reserved to amend details given in this publication without notice

