

MOD. P30

Sensore di livello elettromagnetico Electromagnetic level sensor

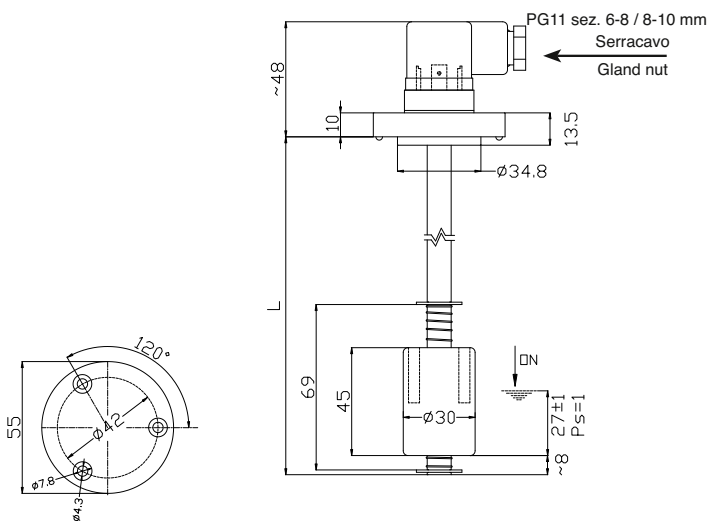

A richiesta disponibile la versione certifi-



Version  available on request

• Impiego	Oli minerali - Carburanti - Acqua
• Fissaggio	Flangia in alluminio 3 fori
• Stelo	Ottone
• Galleggiante	Nylon espanso
• Seeger	Bronzo fosforoso
• O-Ring	NBR
• Connessione elettrica	Connettore DIN 43650
• Tipo contatto	Reed N.A./N.C. (SPDT)
• Max pot. commut.	80 W (50 W SPDT)
• Max corrente commut.	1 A (1 A SPDT)
• Max tensione commut.	250 Vac (220 Vac SPDT)
• Grado di protezione	IP65 IP67
• Tipo di azionamento	1B
• Situazione di inquinazione	normale
• Peso specif. liquido	> 0,75
• Temp. di funzionamento	-15°C / +80°C
• Peso	~ 160 gr (per L=100 mm)

• Use	Mineral oils - Fuels - Water
• Fixing	3 holes aluminum flange
• Stem	Brass
• Float	Foamed nylon
• Seeger	Phosphorous bronze
• O-Ring	NBR
• Electrical connection	Connector DIN 43650
• Type of contact	Reed N.O./N.C. (SPDT)
• Max switch. capacity	80 W (50 W SPDT)
• Max switch. current	1 A (1 A SPDT)
• Max switch. voltage	250 Vac (220 Vac SPDT)
• Protection degree	IP65 IP67
• Action type	1B
• Pollution situation	normal
• Fluid specific weight	> 0,75
• Working temperature	-15°C / +80°C
• Weight	~160 gr (for L=100 mm)

Codice - Part Number

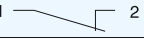
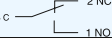
Lunghezza - Length (L=mm)	1  2	3C  2 NC 1 NO
100	P30100 - 100	P30100 - 500
150	P30150 - 100	P30150 - 500
200	P30200 - 100	P30200 - 500
250	P30250 - 100	P30250 - 500
300	P30300 - 100	P30300 - 500
350	P30350 - 100	P30350 - 500
400	P30400 - 100	P30400 - 500
450	P30450 - 100	P30450 - 500
500	P30500 - 100	P30500 - 500

* Per passare da N.C. a N.A. è sufficiente capovolgere il galleggiante

* The contact can be converted from N.C. to N.O. by rotating the float upside down

Contatto SPDT
SPDT Contact

* Per versioni personalizzate (lunghezza, temperatura > 80°C, ecc.) contattare Euroswitch
For customized version (length, temperature > 80°C, etc.) please contact Euroswitch

Per un corretto impiego vedere le note generali del catalogo sensori Euroswitch edizione 10/2010.
For a correct use please refer to "General Notes" in the Euroswitch sensors catalogue, edition 10/2010.