

LED DRIVER SOLUTION FOR LCD BACKLIGHTING

DEVICE DESCRIPTION

The 310 is a single or multi cell LED driver designed for LCD backlighting applications. The input voltage range of the device is between 0.8V and 8V. This means the 310 is compatible with single NiMH, NiCd or Alkaline cells, as well as multi-cell or Lilon batteries.

The device features a shutdown control, resulting in a standby current less than 5µA, and an output capable of driving serial or parallel LED's. The circuit generates constant power output, which are ideal for driving single or multiple LED's over a wide range of operating voltages. These features make the device ideal for driving LED's particularly in LCD backlight applications for Digital Still cameras and PDA's.

FEATURES

- 94% efficiency
- Minimum operating input voltage 0.8V
- Maximum operating input voltage 8V
- Standby current less than 5µA
- Programmable output current
- Series or parallel LED configuration
- Low saturation voltage switching transistor
- SOT23-5 package

APPLICATIONS

- LCD backlights:
 - Digital still camera
 - PDA
 - Mobile phone
- LED flashlights and torches
- White LED driving
- Multiple LED driving

ORDERING INFORMATION

DEVICE	REEL SIZE	TAPE WIDTH	QUANTITY PER REEL
310E5TA	180mm	8mm	3000

DEVICE MARKINGS

- C310
- Package SOT23-5

The 310 is a PFM DC-DC controller IC that drives an external switching transistor with a very low saturation resistance. These transistors are the best switching devices available for this type of conversion enabling high efficiency conversion with low input voltages. The drive output of the 310 LED driver generates a dynamic drive signal for the switching transistor.

The circuit can start up under full load and operates down to an input voltage of 0.8 volts. The solution configuration ensures optimum efficiency over a wider range of load currents; several circuit configurations are possible depending on battery life versus brightness considerations.

The 310 is offered in the SOT23-5 package which, when combined with a SOT23 switching transistor, generates a high efficiency small size circuit solution. The IC and discrete combination offers the ultimate cost Vs performance solution for LED backlight applications.

TYPICAL APPLICATIONS CIRCUIT

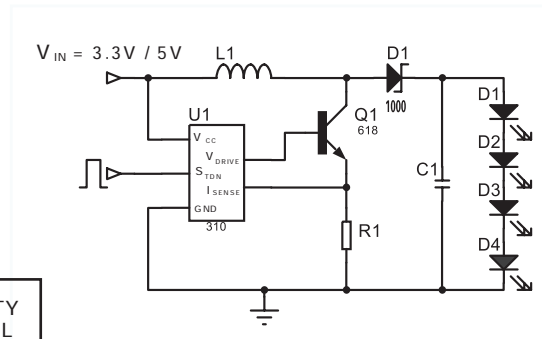

ABSOLUTE MAXIMUM RATINGS:

Supply Voltage	-0.3 to 10V
Maximum Voltage other pins	-0.3 to $V_{CC}+0.3V$
Power Dissipation	450mW
Operating Temperature	-40 to 85 °C
Storage Temperature	-55 to 150°C

ELECTRICAL CHARACTERISTICS:

Test conditions unless otherwise stated: $V_{CC}=1.5V$, $T_{AMB}=25^{\circ}C$

Symbol	Parameter	Conditions	Min	Typ	Max	Units
η	Efficiency ¹				94	%
V_{CC}	Recommended supply voltage range		0.8		8	V
$V_{CC(min)}$	Minimum startup and operating voltage	$I_{DRIVE}=-600\mu A$, $V_{DRIVE}=0.7V$ $I_{DRIVE}=-600\mu A$, $V_{DRIVE}=0.7V$, $T_{AMB}=-10^{\circ}C$		0.8 0.9	0.92	V
I_Q	Quiescent current ²	$V_{EN} = V_{CC}$ (enabled) $V_{EN} = 0V$ (standby)		0.2 5	10	mA μA
I_{VDRIVE}	Base drive current	$V_{DRIVE} = 0.7V$, $V_{ISENSE} = 0V$	1.5		3.5	mA
I_{CC}	Supply current ³	$V_{DRIVE} = 0.7V$, $V_{ISENSE} = 0V$	2		4	mA
$V_{VDRIVE(high)}$	High level drive voltage	$V_{ISENSE} = 0V$, $I_{VDRIVE} = -0.5mA$	V_{CC} -0.3		V_{CC}	V
$V_{VDRIVE(low)}$	Low level drive voltage	$V_{ISENSE} = 50mV$, $I_{VDRIVE} = 5mA$	0		0.2	V
$V_{STDN(high)}$	Device enabled		0.7			V
$V_{STDN(low)}$	Device in standby mode				0.15	V
I_{STDN}	Enable input current		-1		1	μA
V_{ISENSE} (threshold)	Output current reference voltage		14	19	24	mV
$T_{CVISENSE}$	I_{SENSE} voltage temp co. ²			0.4		%/°C
I_{ISENSE}	I_{SENSE} input current	$V_{ISENSE} = 0V$	0	-30	-65	μA
T_{DRV}	Discharge Pulse Width		1.2	1.7	3.2	μs

OPERATING CONDITIONS

Symbol	Parameter	Conditions	Min	Typ	Max	Units
F_{OSC}	Recommended operating frequency ⁴				200	kHz

1 Application dependent, see reference designs

2 These parameters guaranteed by Design and characteristics

3 Total supply current = $I_Q + I_{VDRIVE}$, see typical characteristics

4 Operating frequency is application circuit dependent. See applications section.

618

For the circuits described in the applications section 618 is the recommended pass transistor. The following indicates outline data for the device, more detailed information can be found in the surface mount products data book or on Web

ELECTRICAL CHARACTERISTICS:

Test conditions unless otherwise stated: T_{AMB}=25°C

Symbol	Parameter	Conditions	Min	Typ	Max	Units
V _{CE(sat)}	Collector-Emitter Saturation Voltage ⁵	I _C =0.1A, I _B =10mA		8	15	mV
		I _C =1A, I _B =10mA		70	150	
		I _C =2.5A, I _B =50mA		130	200	
V _{(BR)CEO}	Collector-Emitter Breakdown Voltage ⁵	I _C =10mA	20	27		V

⁵ Measured under pulse conditions. Pulse width=300µs. Duty cycle ≤2%

1000

For the maximum brightness circuit described in the applications section 1000 is the recommended Schottky diode. The following indicates outline data for the more detailed information can be found on Web

ELECTRICAL CHARACTERISTICS:

Test conditions unless otherwise stated: T_{AMB}=25°C

Symbol	Parameter	Conditions	Min	Typ	Max	Units
V _F	Forward voltage	I _F = 500mA I _F = 1A			400 500	mV
t _{rr}	Reverse Recovery Time	Switched from I _F =500mA to I _R =500mA. Measured at I _R =50mA		12		ns
I _R	Reverse Current	V _R = 30V		50	100	µA

Part Number	V _R	I _F	I _{FSM}	V _F at		I _R at		Capacitance at V _R = 25V, f = 1MHz	Package
	Max. V	Max. mA	Max. A	Max. mV	I _F mA	Max. µA	V _R V	Typ. pF	
BAT54	30	200	0.6	500	30	250	25	10	SOT23-6
2000	40	2000	20	500	2000	1000	30	60	SOT23
1000	40	1000	12	500	1000	100	30	25	SOT23
750	40	750	12	540	750	100	30	25	SOT23
500	40	500	6.75	550	500	40	30	20	SOT23
400	40	400	6.75	500	400	40	30	20	SOT323

TYPICAL CHARACTERISTICS

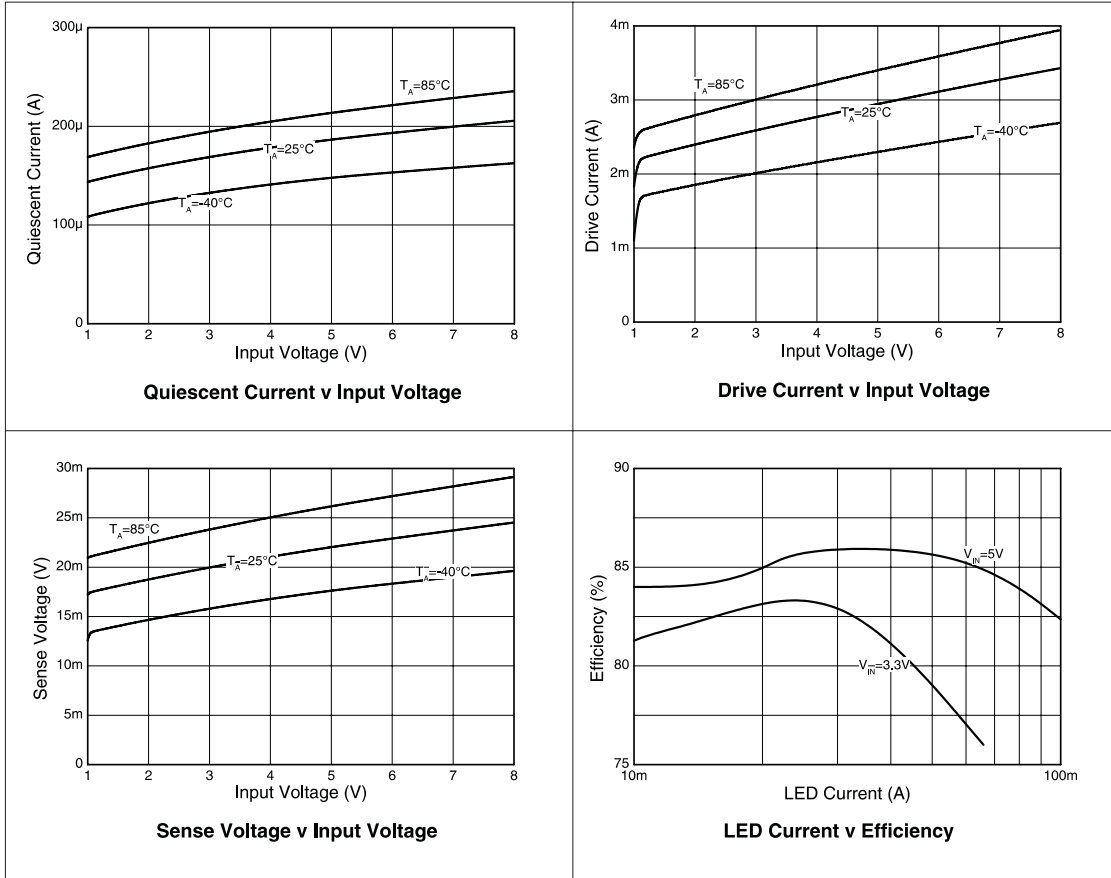

DEVICE DESCRIPTION

The 310 is PFM, controller IC which, when combined with a high performance external transistor, enables the production of a high efficiency boost converter for LED driving applications. A block diagram is shown for the 310 below.

The on chip comparator forces the driver circuit and therefore the external switching transistor off if the voltage at I_{SENSE} exceeds 19mV. An internal reference circuit and divider set this threshold.

The voltage at I_{SENSE} is taken from a current sense resistor connected in series with the emitter of the switching transistor. A monostable following the output of the comparator forces the turn-off time of the output stage to be typically 1.7us. This ensures that there is sufficient time to discharge the inductor coil before the next on period.

With every on pulse the switching transistor is kept on until the voltage across the current-sense resistor exceeds the threshold of the I_{SENSE} input. The on-pulse length, and therefore the switching frequency, is determined by the programmed peak current, the input voltage and the input to output voltage differential. See applications section for details.

The driver circuit supplies the external switching transistor with a fixed drive current. To maximise efficiency the external transistor switched quickly, typically being forced off within 30ns.

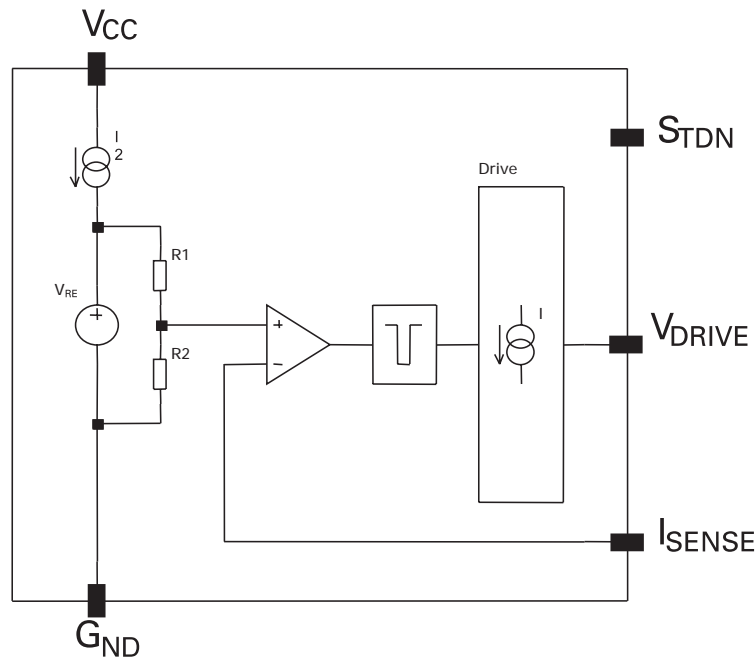

310 Block Diagram

REFERENCE DESIGNS

Three typical LED driving applications are shown. Firstly a typical LCD backlight circuit, then maximum brightness LED driving solution and lastly an optimised battery life LED driving solution.

LCD backlight circuit

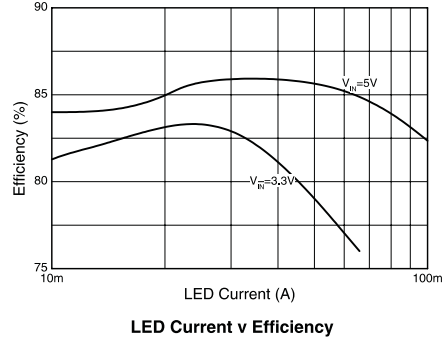
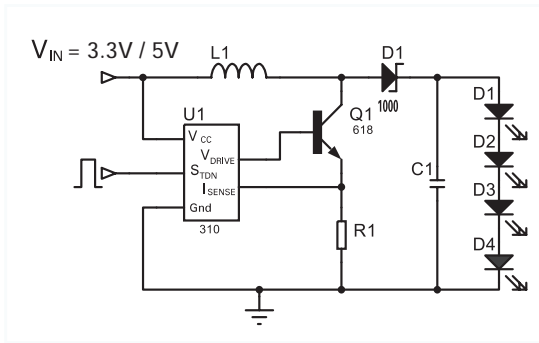

(Notes)

This application shows the 310 in a typical LCD backlight application for Digital Still Cameras and PDA's. The input voltage for these backlight circuits are usually fixed from the main system power, typically 3.3V or 5V. The LED's are connected serially so that the light is distributed uniformly in each LED. The current provided to the LED's can either be pulsed or DC. The DC current is programmable via a sense resistor, RSENSE, and is set to an optimum LED current of 20mA for the reference designs. DC current is achieved by adding a Schottky rectifying diode and an output capacitor, as shown in the reference design below.

Materials list

Ref	Value	Part Number	Manufacture	Comments
U1	N/A	310	PIC	SOT23-5
Q1	N/A	618	PIC	Low $V_{CE(sat)}$ NPN, SOT23
D1	N/A	1000	PIC	1A Schottky diode, SOT23
C1	2.2 μ F	Generic	Various	0805 Size
R1 ⁶	150m Ω	Generic	Various	1206 Size
R1 ⁷	250m Ω	Generic	Various	1206 Size
L1 ⁸	68 μ H			Surface mount inductor

⁶Used for 3.3V input, I_{LED} set to 20mA \pm 10%.

⁷Used for 5V input, I_{LED} to 20mA \pm 10%.

⁸See Application section.

Maximum brightness solution

(Notes)

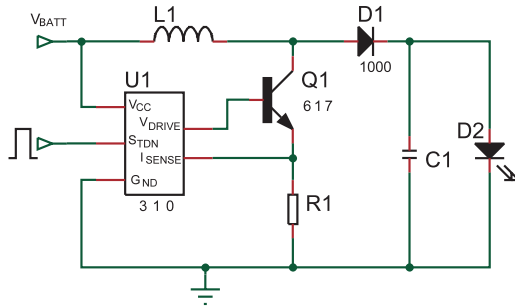

This circuit provides a continuous current output to the LED by rectifying and buffering the DC-DC output. This ensures maximum LED brightness.

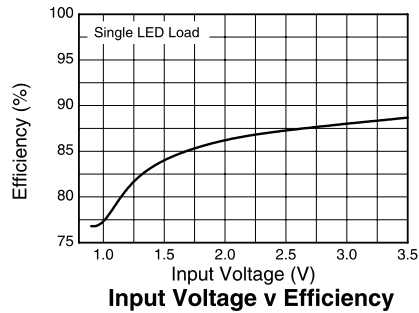

Materials list

Ref	Value	Part Number	Manufacturer	Comments
U1	N/A	310E5	Plc	Single cell converter, SOT23-5
Q1	N/A	617	Plc	Low $V_{CE(sat)}$ NPN, SOT23
D1	1A	1000	Plc	1A Schottky diode, SOT23
R1	100mΩ	Generic	Variou	0805 Size
C1	2.2μF	Generic	Various	Low ESR ceramic capacitor
L1	100μH ⁸			Surface mount inductor

(Notes)

Maximum battery life solution

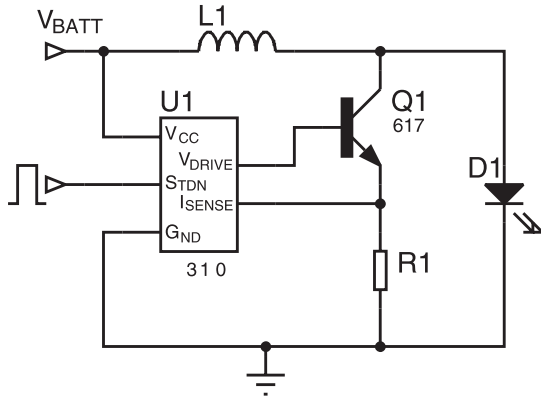

To ensure optimum efficiency, and therefore maximum battery life, the LED is supplied with a pulsed current. Maximum efficiency is ensured with the removal of rectifier losses experienced in the maximum brightness solution.

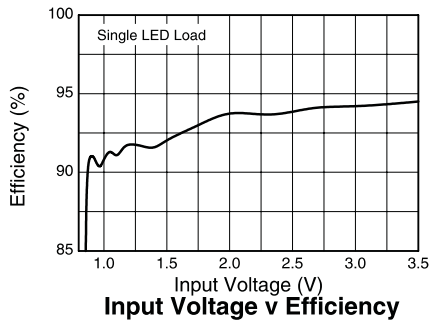

Materials list

Ref	Value	Part Number	Manufacturer	Comments
U1	NA	310E5	Plc	Single cell converter, SOT23-5
Q1	NA	617	Plc	Low $V_{CE(SAT)}$ NPN, SOT23
R1	330mΩ	Generic	Various	0805 Size
L1	100μH ⁸			Surface mount inductor

APPLICATIONS INFORMATION

The following section is a design guide for optimum converter performance.

Switching transistor selection

The choice of switching transistor has a major impact on the converter efficiency. For optimum performance, a bipolar transistor with low $V_{CE(SAT)}$ and high gain is required.

The 618 is an ideal choice of transistor, having a low saturation voltage. A data sheet for the 618 is available on web site or through your local sales office. Outline information is included in the characteristics section of this data sheet.

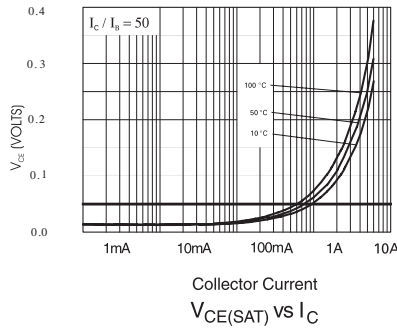

Schottky diode selection

For the maximum battery life solution a Schottky rectifier diode is not required. As with the switching transistor the Schottky rectifier diode has a major impact on the converter efficiency. A Schottky diode with a low forward voltage and fast recovery time should be used for this application.

The diode should be selected so that the maximum forward current is greater or equal to the maximum peak current in the inductor, and the maximum reverse voltage is greater or equal to the output voltage.

The 1000 meets these needs. Datasheets for the ZH Series are available on web site or through your local sales office. Outline information is included in the characteristics section of this data sheet.

For the maximum brightness solution a pulsed current is supplied to the LED and thus a Schottky rectifier diode is required.

Inductor selection

The inductor value must be chosen to satisfy performance, cost and size requirements of the overall solution. For the LCD backlight reference design we recommend an inductor value of 68uH with a core saturation current rating greater than the converter peak current value and low series resistance.

Inductor selection has a significant impact on the converter performance. For applications where efficiency is critical, an inductor with a series resistance of 500mΩ or less should be used.

A list of recommended inductors is shown in the table below:

Part No.	Manufacture	L	I_{PK}	R_{DC}
DO1608C-683	Coilcraft	68μH	0.4A	0.86Ω
CR54-680	Sumida	68μH	0.61A	0.46Ω
P1174.683	Pulse	68μH	0.4A	0.37Ω
SFOP5845-R61680	Samwha	68μH	0.61A	0.46Ω
SIS43-680	Delta	68μH	0.4	1.125Ω

Peak current definition

The peak current rating is a design parameter whose value is dependent upon the overall application. For the high brightness reference designs, a peak current of was chosen to ensure that the converter could provide the required output power to the LED.

In general, the I_{PK} value must be chosen to ensure that the switching transistor, Q1, is in full saturation with maximum output power conditions, assuming worst-case input voltage and transistor gain under all operating temperature extremes.

Once I_{PK} is decided the value of R_{SENSE} can be determined by:

$$R_{SENSE} = \frac{V_{ISENSE}}{I_{PK}}$$

A selection guide of sense resistor and inductor values for given input voltages, output currents and number of LED connected in series is provided in the table below.

Input Voltage (V)	LED current (mA)	No. of LED's	R_{SENSE} (m Ω)	Inductor (μ H)	Efficiency (%)
3.3V	10	3	510	68	80
3.3V	10	4	330	68	81
3.3V	10	6	150	68	79
3.3V	20	3	220	68	84
3.3V	20	4	150	68	93
3.3V	20	6	77	68	79
3.3V	30	3	170	68	84
3.3V	30	4	100	68	84
3.3V	30	6	47	68	77
5V	10	3	750	68	83
5V	10	4	510	68	84
5V	10	6	330	68	79
5V	20	3	440	68	85
5V	20	4	250	68	85
5V	20	6	150	68	82
5V	30	3	330	68	86
5V	30	4	170	68	85
5V	30	6	100	68	83

Output Power Calculation

By making the above assumptions for inductance and peak current the output power can be determined by:

$$P_{OUT} = (V_{OUT} - V_{IN}) \times I_{AV} \times \frac{T_{OFF}}{T_{ON} + T_{OFF}}$$

Note: V_{OUT} = output voltage + Schottky rectifier voltage drop.

Where

$T_{OFF} \cong 1.7\mu s$ (internally set by 310)

and

$$T_{ON} = \frac{T_{OFF}(V_{OUT} - V_{IN})}{V_{IN}}$$

and

$$I_{AV} = \frac{I_{PK} + I_{MIN}}{2}$$

Where

$$I_{MIN} = I_{PK} - \frac{V_{OUT} - V_{IN} \times T_{OFF}}{L}$$

Operating frequency can be derived by:

$$F = \frac{1}{(T_{ON} + T_{OFF})}$$

Capacitor selection

For pulsed operation, as in the maximum battery life solution, no capacitors are required at the output to the LED. For rectified operation, as in the maximum brightness solution, a small value ceramic capacitor is required, typically 2.2 μF .

Generally an input capacitor is not required, but a small ceramic capacitor may be added to aid EMC, typically 470nF to 1 μF .

(notes)

Shutdown Control

The 310 offers a shutdown mode that produces a standby current of less than 5uA when in operation. When the voltage at the S_{TDN} pin is 0.7V or higher the 310 is enabled, hence the driver is in normal operation. When the voltage at the S_{TDN} pin is 0.1V or lower the 310 is disabled, hence the driver is in shutdown mode. If the S_{TDN} pin is open circuit the 310 is also enabled.

Demonstration board

A demonstration board for the LCD backlighting solution, is available upon request. These can be obtained through your local office or through web pages. For all reference designs Gerber files and bill of materials can be supplied.

Layout of LCD backlighting solution

Top Silk

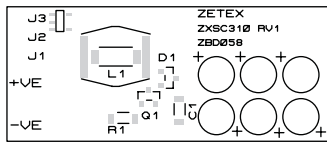

Drill File

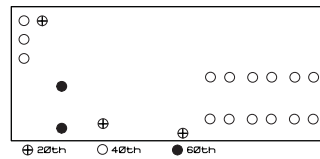

Top Copper



Bottom Copper



PINOUT DIAGRAM

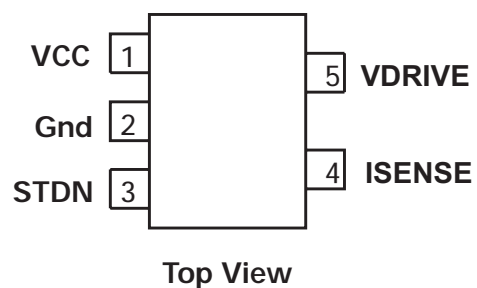

PIN DESCRIPTIONS

Pin No.	Name	Description
1	V_{CC}	Supply voltage, generally Alkaline, NiMH or NiCd single cell
2	G_{nd}	Ground
3	S_{TDN}	Shutdown
4	I_{SENSE}	Inductor current sense input. Internal threshold voltage set to 19mV. Connect external sense resistor
5	V_{DRIVE}	Drive output for external switching transistor. Connect to base of external switching transistor.

SOT23-5 PACKAGE OUTLINE

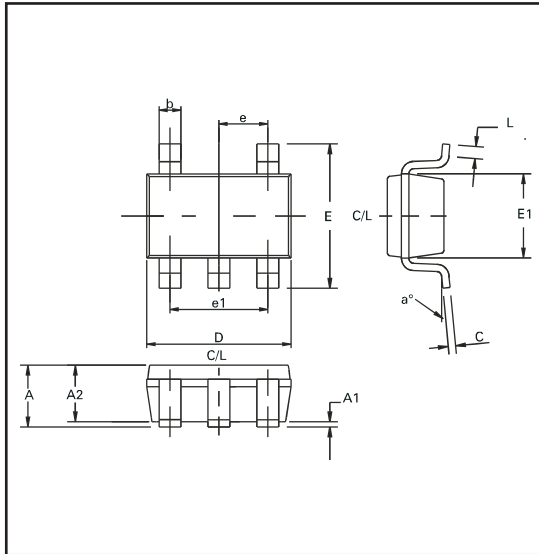

SOT23-5 PACKAGE DIMENSIONS

DIM	Millimeters		Inches	
	MIN	MAX	MIN	MAX
A	0.90	1.45	0.035	0.057
A1	0.00	0.15	0.00	0.006
A2	0.90	1.3	0.035	0.051
b	0.35	0.50	0.014	0.020
C	0.09	0.20	0.0035	0.008
D	2.80	3.00	0.110	0.118
E	2.60	3.00	0.102	0.118
E1	1.50	1.75	0.059	0.069
e	0.95 REF		0.037 REF	
e1	1.90 REF		0.075 REF	
L	0.10	0.60	0.004	0.024
a°	0	10	0	10