

## Measuring relay MMU / under or over voltage, 1 or 3 phases with 1 Changeover 17.5mm housing



### Application

Measures three-phase systems for under voltage, over voltage and phase failure.

### Description

The **MMU / under and over voltage relay** measures the three phases of either AC or DC for under voltage, over voltage and phase failure. Hysteresis and time delay can be individually selected. These functions can be adjusted with DIP switches on the front panel of the relay. The relay is powered by the connection to phase L1 (L1 – N > 170V AC). In addition, the star point (neutral) of the phase or three phases to be monitored must be connected. The green LED indicates the connection of the power supply.

### Function

#### Under voltage, phase monitoring, Hysteresis

After connecting the relay, if the phase voltage exceeds the selected values plus hysteresis, the relay switches immediately into its working position (relay energizes). This status is indicated by the red LED. If the phases fall below the selected value or the neutral drops out, the relay switches to its rest position. The hysteresis tolerance can be adjusted between 5 and 15%. The MMU senses the phase angle and will also switch off if the user generates a back feed.

### Part number

012011      **MMU under or over voltage  
1 Changeover**  
U < : L – N    180 – 230V AC  
U > : L – N    230 – 260V AC

#### Under voltage, phase monitoring, time

After connecting the relay, if the phase voltage meets the selected values, the relay switches immediately into its work position (relay energizes). This status is indicated by the red LED. The relay switches to its rest position if the phases fall below the selected values longer than the desired timing or the neutral drops out. The relay's reaction time can be adjusted between 0.5 and 10 seconds.

#### Under voltage, 3 phase monitoring, Hysteresis

If all three phase voltages exceed the selected values plus hysteresis, the relay switches immediately into its working position (relay energizes). This status is indicated by the red LED. The relay switches to its rest position if at least one of the phases falls below the selected values or the neutral drops out. The hysteresis tolerance can be adjusted between 5 and 15%.

#### Under voltage, 3 phase monitoring, time

If all three phase voltages exceed the selected values, the relay switches immediately into its work position (relay energizes). This status is indicated by the red LED. If at least one of the phases falls below the desired values longer than the selected time or the neutral drops out, the relay switches into its rest position. The relay's reaction time can be adjusted between 0.5 and 10 seconds.

#### Over voltage, phase monitoring, Hysteresis

The relay switches into its work position if the monitored phases are below the selected values (relay energizes). This status is indicated by the red LED. If the phase exceeds the selected value the relay switches into its rest position. When the phase falls below the selected values minus hysteresis, the relay returns to its working position. The hysteresis tolerance can be adjusted between 5 and 15%.

#### Over voltage, phase monitoring, time

The relay switches into its work position if the monitored phases are below the selected values (relay energizes). This status is indicated by the red LED. If the phase exceeds the desired values longer than the selected time, the relay switches into its rest position. When the phase falls below the selected values the relay returns to its work position. The reaction time of the relay can be adjusted between 0.5 and 10 seconds.

Measuring relay  
**MMU / under or over voltage, 1 or 3 phases with 1 Changeover**  
 17.5mm housing

**Over voltage, 3 phase monitoring, Hysteresis**

The relay switches into its working position as long as all three phases are below the selected values (relay energizes). This status is indicated by the red LED. The relay switches into its rest position if at least one of the three phases exceeds the selected values. The relay switches into its work position as soon as the phase or phases falls below the selected values minus hysteresis. The hysteresis tolerance can be adjusted between 5 and 15%.

**Over voltage, 3 phase monitoring, time**

The relay switches into its working position as long as all three phases are below the selected values (relay energizes). This status is indicated by the red LED. The relay switches into its rest position if at least one phase exceeds the desired values longer than the selected time. The relay switches immediately into its work position as soon as the phase or phases falls below the selected values. The response time of the relay can be adjusted between 0.5 and 10 seconds.

**Options**

Other timing ranges, hysteresis tolerances and measuring ranges upon request.

**DIP switch adjustments**

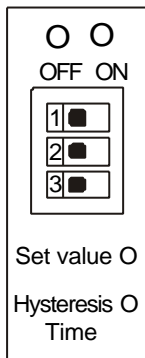

ON – Under voltage: 180...230V AC  
 OFF – Over voltage: 230...260V AC

ON – 1 phase  
 OFF – 3 phases

ON – Hysteresis 5...15%  
 OFF – Time 0.5...10s

**Approvals**



**Function diagram**

**Under voltage with Hysteresis**

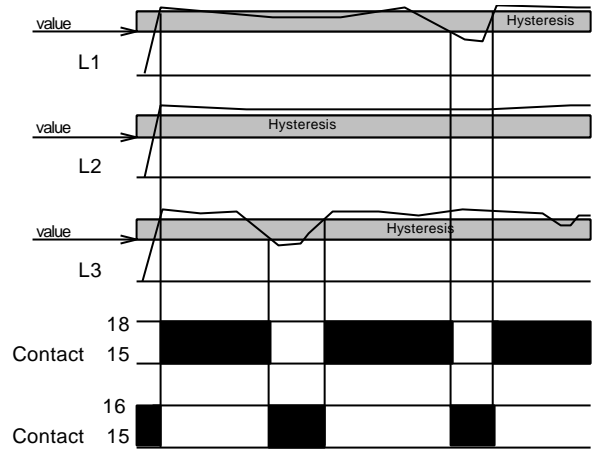

**Under voltage with time**

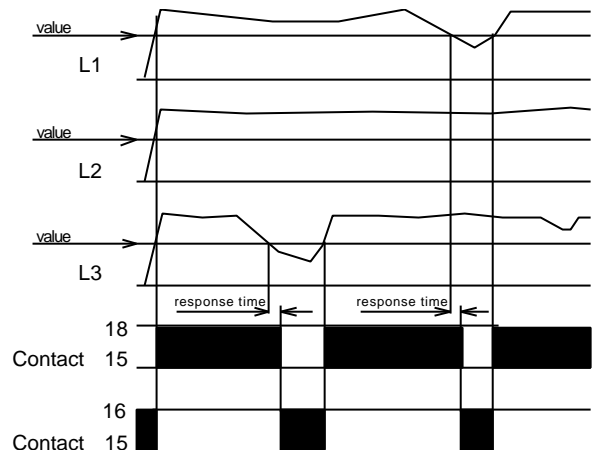

**Over voltage with Hysteresis**

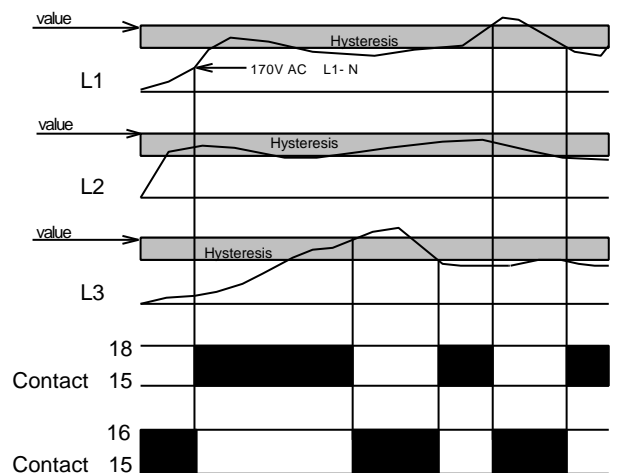

Measuring relay  
**MMU / under or over voltage, 1 or 3 phases with 1 Changeover**  
 17.5mm housing

**Over voltage with time**

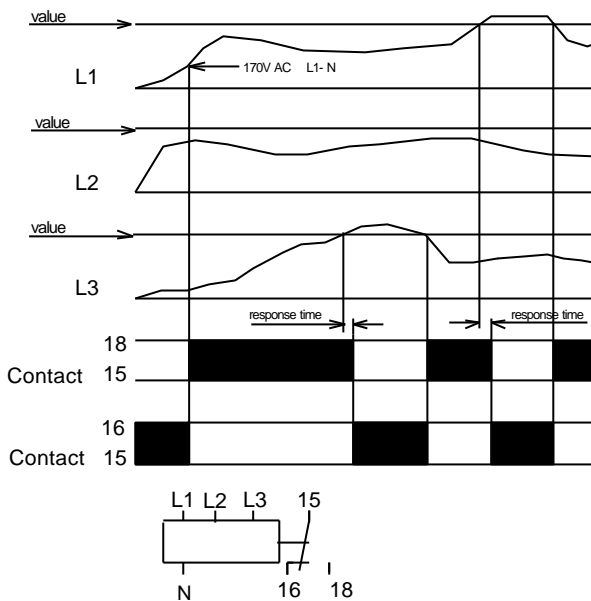

**Mounting**

Snap-on mounting using a standard DIN rail EN 50022. The unit is designed to allow side-by-side mounting, with an ambient temperature of < 60°C.

**Technical data**

**Supply**

Supply voltage: 3 x 400V AC / N  
 Frequency range: 50 ... 60Hz  
 Power consumption: 8VA

**Operating mode:**

continuous

**Adjustment range**

U > : 230...270V AC  
 U < : 170...230V AC  
 ΔU : 5...15%  
 t<sub>v</sub> : 0.5...10 sec.  
 Measuring accuracy: 5% over the entire temperature and voltage range

**Repetitive accuracy:**

± 2%

**Operation indicators**

Supply voltage: LED, green  
 Relay in work position: LED, red

**Contact**

Number of changeovers: 1  
 Contact material: AgSnO<sub>2</sub>  
 Maximum switching voltage: 250V AC  
 Maximum switching current: 4A  
 Drop-off time of switching element: approx. 20ms  
 Mechanical life: 30 Mio.  
 Electrical life (with rated load): 0.8 Mio.

**General data**

Ambient temperature: - 25 ... + 60°C  
 Climate resistance: VDE 0435T.2021  
 Mounting position: any  
 Vibration resistance: VDE 0435T.2021  
 Test voltage: 2.5kV  
 Isolation group: VDE 0110 Group C 250  
 Protection class: Terminals IP 20  
 Housing IP 40  
 Connection terminals: Crosshead screws; M3.5 self opening  
 Connection cross section: Multi-strand wire with wire sleeves 2 x 2.5mm<sup>2</sup>  
 single wire 2 x 2.5mm<sup>2</sup>  
 Finger touch protection: VDE 0106T.100 and VBG4  
 Mounting: Symmetrical DIN rail EN 50022  
 Dimensions l x w x h: 90mm x 17.5mm x 69.5mm  
 Weight: 86g

Measuring relay  
**MMU / under or over voltage, 1 or 3 phases with 1 Changeover**  
 17.5mm housing

**Example**

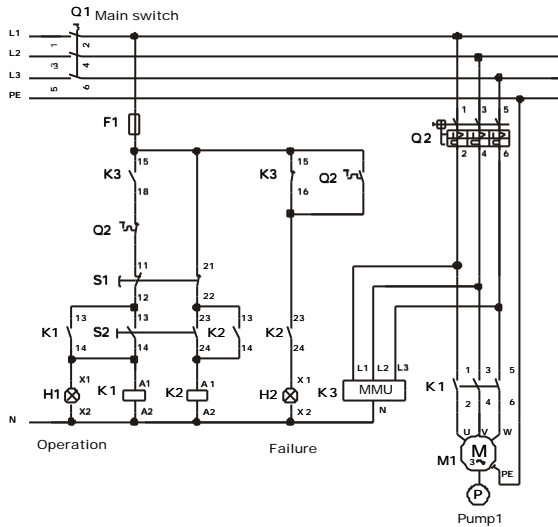

The MMU monitors the pump motor for over voltage.

**Dimensions**

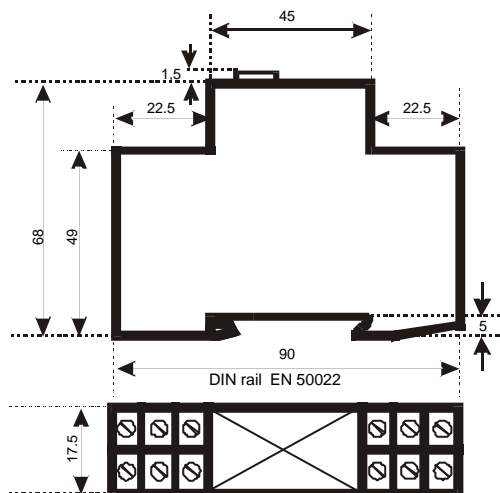

**Connections**

The terminal assignment for the connections is located on the front panel of the relay. **Reading the front panel from top to bottom**, the connections are in the following order:

Upper side	Right:	L2 – N – nc
	Left:	L1 – L3 – nc
Lower side	Right:	nc – 15 – 18
	Left:	nc – nc – 16

上海悦中电气设备有限公司  
 上海恒通路360号一天下大厦24C  
 TEL: 021-62246890  
 FAX: 021-52240873  
 Http://www.skjd.cn  
 E-mail: shskjd@126.com