

Timers

Fully programmable

Type DHA51



- Fully programmable timing unit
- The function is designed with the BHF PC software
- Waveform design capability:
 - up to 32 status changes
 - each status time range 0.1 s to 100 h
 - programmable trigger input event
- Full reprogrammability of the timing functions
- Repeatability: $\leq 0.2\%$
- Output: 5 A SPDT relay
- For mounting on DIN-rail in accordance with DIN/EN 50 022
- 17.5 mm DIN-rail housing
- Combined AC and DC power supply
- LED indication for relay status and power supply ON

Product Description

DHA51 is a fully programmable timer to allow execution of self-designed timing functions. The function can be prepared using the free PC software BHF

and connecting the unit to the PC.
For mounting on DIN-rail, 17.5 mm wide housing suitable both for back and front panel mounting.

Ordering Key

DHA 51 C M24 S8

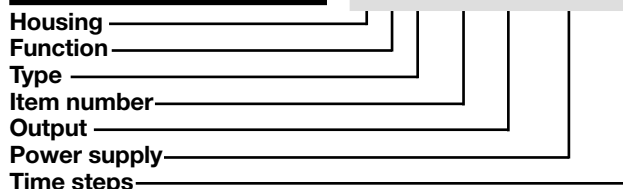

Type Selection

Mounting	Output	Housing	Time steps	Supply: 24 VDC and 24 to 240 VAC
DIN-rail	SPDT	Mini-D	8 steps	DHA 51 C M24 S8
DIN-rail	SPDT	Mini-D	16 steps	DHA 51 C M24 S16
DIN-rail	SPDT	Mini-D	32 steps	DHA 51 C M24 S32

Time Specifications

Time ranges	each step 0.1 to 1 s 1 to 100 s 6 to 600 s 60 to 6000 s 0.1 to 10 h 1 to 100 h
Setting accuracy	$\leq 0.1\%$ +/- 10 ms of the set value for each step
Repeatability	$\leq 0.2\%$
Time variation	Within rated power supply $\leq 0.05\%/V$ Within ambient temperature $\leq 0.2\%/^{\circ}C$
Reset	Manual reset of time and/or relay Pulse duration ≥ 100 ms Power supply interruption ≥ 200 ms

Output Specifications

Output	SPDT relay
Rated insulation voltage	250 VAC (rms)
Contact Ratings (AgSnO₂)	μ
Resistive loads	AC 1 5 A @ 250 VAC DC 12 5 A @ 24 VDC
Small inductive loads	AC 15 2.5 A @ 250 VAC DC 13 2.5 A @ 24 VDC
Mechanical life	$\geq 30 \times 10^6$ operations
Electrical life	$\geq 10^5$ operations (at 5 A, 250 V, $\cos \varphi = 1$)
Operating frequency	< 7200 operations/h
Dielectric strength	
Dielectric voltage	2 kVAC (rms)
Rated impulse withstand voltage	2.5 kV (1.2/50 μ s)

Supply Specifications

Power supply Rated operational voltage through terminals A1, A2	Oversvoltage cat. II (IEC 60664, IEC 60038) 24 VDC \pm 15% and 24 to 240 VAC + 10% -15%, 45 to 65 Hz
Voltage interruption	\leq 10 ms
Rated operational power	1.5 W

Function/Time Setting

T-RUN PCABLE/PCABLEII (optional): Connected to the parallel port of your Personal Com-	puter allows complete programming of function and timing for the unit using the software BHF.
--	---

Accessories

T-RUN PCABLE/PCABLEII (optional): To be connected to the parallel port of your personal computer.	BHF software: to be downloaded from the CARLO GAVAZZI site following the links for software download. See www.carlogavazzi.com
---	---

Mode of Operation

With DHA51 it is extremely simple to obtain self-designed timing functions just preparing two diagrams with the PC configuration software BHF: one describing what happens at power on and one at the trigger (closing or opening). This allows a variety of application that only fantasy is able to determine.

After preparing the function on the PC it is enough to connect the T-RUN PCABLE to the plug and program the unit. DHA51 becomes your self-customized timer with exactly the function you needed. Refer to BHF software for more information.

Example 1:
Setting a 3-blinks function plus a start activity. As soon as the power supply is applied three pulses are executed. Each one is separated by the following one by one second and the duration is respectively 4, 3, and 2 s. Closing the trigger contact causes the three 1 s pulses. In every case, after finishing the planned sequence, the unit waits for the new trigger. In case of trigger event before finishing the power on sequence, the trigger sequence starts.

Example2:
Shifting trigger
At the power on a single pulse is programmed as acknowledge. In this case both the closing and opening events of the trigger are recorded. The output is the same event as the trigger delayed of the predetermined period of time. Every new trigger activity is shifted to the output.

Additional load
It's possible to wire an additional load (i.e. a relay) between pins Y1 and A2, driven by the trigger contact without damaging the device.

Relay ON: See operation diagrams

Note 1:
The power supply voltage MUST be switched OFF while the modular plug is connected to the unit.

Note 2:
DHA51 can be reprogrammed (e.g.: in case of change of function or during the testing phase) several times using every time the same procedure.

Note 3:
The above examples are just small instances to show how easy is to obtain more and more nice and useful functions using DHA51.

General Specifications

Power ON delay	\leq 100 ms
Indication for Power supply ON Output relays ON	LED, green LED, yellow (flashing when timing)
Environment Degree of protection Pollution degree Operating temperature Storage temperature	(EN 60529) IP 20 2 (IEC 60664) -20° to +60°C, R.H. < 95% -30° to +80°C, R.H. < 95%
Housing dimensions	17.5 x 81 x 67.2 mm
Weight	75 g
Screw terminals Tightening torque	Max. 0.5 Nm according to IEC EN 60947
Approvals	UL, CSA
CE Marking	Yes
EMC Immunity Emission	Electromagnetic Compatibility According to EN 61000-6-2 According to EN 61000-6-3

Dimensions

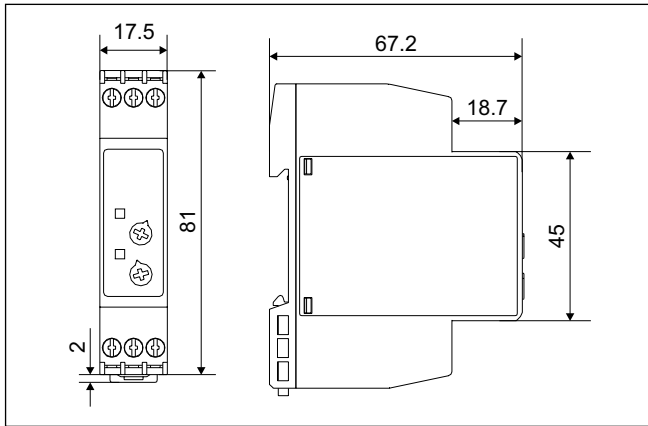

Wiring Diagram

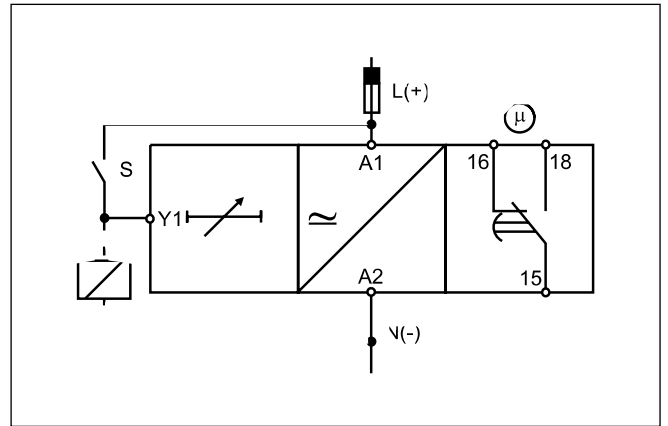

Operation Diagrams

Example 1: power on sequence

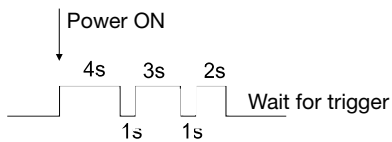

Example 1: trigger sequence

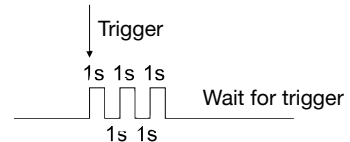

Example 1: activity

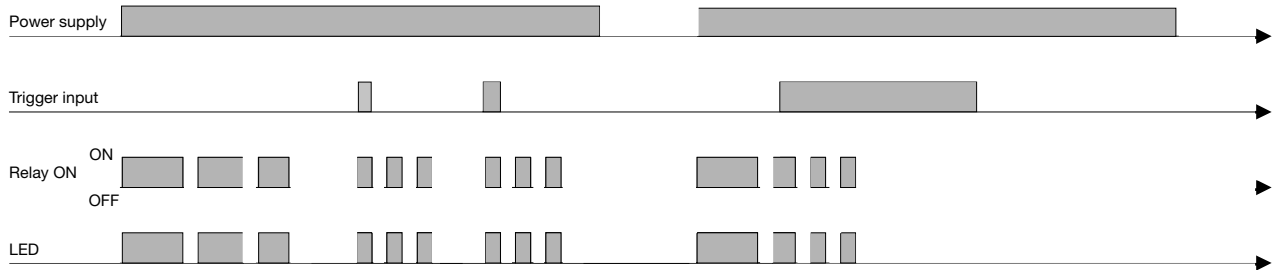

Example 2: power on sequence

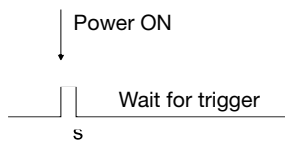

Example 2: trigger sequence

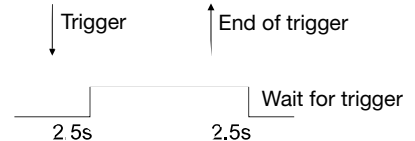

Example 2: activity

