

Monitoring Relays

1-Phase True RMS AC/DC Over or Under Voltage

Types DUB01, PUB01



DUB01



PUB01

- TRMS AC/DC over or under voltage monitoring relays
- Selection of measuring range by DIP-switches
- Measuring ranges from 0.1 to 500 V AC/DC
- Adjustable voltage on relative scale
- Adjustable hysteresis on relative scale
- Adjustable delay function (0.1 to 30 s)
- Programmable latching or inhibit at set level
- Output: 8 A SPDT relay N.D. or N.E. selectable
- For mounting on DIN-rail in accordance with DIN/EN 50 022 (DUB01) or plug-in module (PUB01)
- 22.5 mm Euronorm housing (DUB01) or 36 mm plug-in module (PUB01)
- LED indication for relay, alarm and power supply ON

Product Description

DUB01 and PUB01 are precise TRMS AC/DC over or under voltage (selectable by DIP-switch) monitoring relays. Owing to the built-in latch function, the ON-position of the relay output can be

maintained. Inhibit function can be used to avoid relay operation when not desired (maintenance, transitions). The LED's indicate the state of the alarm and the output relay.

Ordering Key

DUB 01 C B23 10V

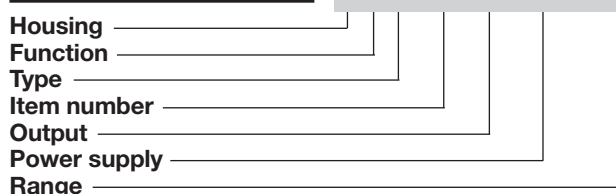

Type Selection

Mounting	Output	Measuring range	Supply: 24 VDC	Supply: 48 VDC	Supply: 24/48 VAC	Supply: 115/230 VAC
DIN-rail	SPDT	0.1 to 10 V AC/DC	DUB 01 C 724 10V	DUB 01 C 748 10V	DUB 01 C B48 10V	DUB 01 C B23 10V
		2 to 500 V AC/DC	DUB 01 C 724 500V	DUB 01 C 748 500V	DUB 01 C B48 500V	DUB 01 C B23 500V
Plug-in	SPDT	0.1 to 10 V AC/DC	PUB 01 C 724 10V	PUB 01 C 748 10V	PUB 01 C B48 10V	PUB 01 C B23 10V
		2 to 500 V AC/DC	PUB 01 C 724 500V	PUB 01 C 748 500V	PUB 01 C B48 500V	PUB 01 C B23 500V

Input Specifications

Input			
Voltage level	DUB01: Terminals Y1, Y2 PUB01: Terminals 5, 7		
Measuring ranges	Internal resist.	Max. volt.	
..10V:	0.1 to 1 V AC/DC	>200 kΩ	100 V
	0.2 to 2 V AC/DC	>200 kΩ	100 V
	0.5 to 5 V AC/DC	>200 kΩ	100 V
	1 to 10 V AC/DC	>200 kΩ	100 V
	Max. voltage for 1 s		200 V
..500V:	2 to 20 V AC/DC	>500 kΩ	350 V
	5 to 50 V AC/DC	>500 kΩ	350 V
	20 to 200 V AC/DC	>500 kΩ	600 V
	50 to 500 V AC/DC	>500 kΩ	600 V
	Max. voltage for 1 s		1000 V
Note:	The input voltage cannot raise over 300 VAC/DC with respect to ground (PUB01 only)		
Contact input			
DUB01	Terminals Z1, Y1		
PUB01	Terminals 8, 9		
Disabled	> 10 kΩ		
Enabled	< 500 Ω		
Latch disable	> 500 ms		

Output Specifications

Output	SPDT relay
Rated insulation voltage	250 VAC
Contact ratings (AgSnO₂)	μ
Resistive loads	AC 1 DC 12
Small inductive loads	AC 15 DC 13
	8 A @ 250 VAC 5 A @ 24 VDC 2.5 A @ 250 VAC 2.5 A @ 24 VDC
Mechanical life	≥ 30 x 10 ⁶ operations
Electrical life	≥ 10 ⁵ operations (at 8 A, 250 V, cos φ = 1)
Operating frequency	≤ 7200 operations/h
Dielectric strength	
Dielectric voltage	≥ 2 kVAC (rms)
Rated impulse withstand volt.	4 kV (1.2/50 μs)

Supply Specifications

Power supply Rated operational voltage through terminals: A1, A2 or A3, A2 (DUB01) 2, 10 or 11, 10 (PUB01) 724: 748: B48: B23:	Overvoltage cat. III (IEC 60664, IEC 60038) 24 VDC \pm 20%, insulated 48 VDC \pm 20%, insulated 24/48 VAC \pm 15% 45 to 65 Hz, insulated 115/230 VAC \pm 15% 45 to 65 Hz, insulated
Dielectric voltage Supply to input Supply to output Input to output	DC supply AC supply 2 kV 4 kV 4 kV 4 kV 4 kV 4 kV
Rated operational power AC DC	4 VA 3 W

General Specifications

Power ON delay	1 s \pm 0.5 s or 6 s \pm 0.5 s
Reaction time	(input signal variation from -20% to +20% or from +20% to -20% of set value) Alarm ON delay < 100 ms Alarm OFF delay < 100 ms
Accuracy Temperature drift Delay ON alarm Repeatability	(15 min warm-up time) \pm 1000 ppm/ $^{\circ}$ C \pm 10% on set value \pm 50 ms \pm 0.5% on full-scale
Indication for Power supply ON Alarm ON Output relay ON	LED, green LED, red (flashing 2 Hz during delay time) LED, yellow
Environment Degree of protection Pollution degree Operating temperature Storage temperature	IP 20 3 (DUB01), 2 (PUB01) -20 to 60 $^{\circ}$ C, R.H. < 95% -30 to 80 $^{\circ}$ C, R.H. < 95%
Housing dimensions DIN-rail version Plug-in version	22.5 x 80 x 99.5 mm 36 x 80 x 94 mm
Weight	Approx. 150 g
Screw terminals Tightening torque	Max. 0.5 Nm acc. to IEC 60947
Approvals	UL, CSA (except 748)
CE Marking	Yes
EMC Immunity Emission	Electromagnetic Compatibility According to EN 61000-6-2 According to EN 61000-6-3

Mode of Operation

DUB01 and PUB01 monitor both AC and DC over or under voltage.

Example 1

(no connection between terminals Z1, Y1 or 8, 9 - latch function disabled)

The relay operates when the measured value exceeds (or drops below) the set level for more than the set delay time. It releases when the voltage drops below (or exceeds) the

set level (see hysteresis setting), or when power supply is interrupted.

Example 2

(connection between terminals Z1, Y1 or 8, 9 - latch function enabled)

The relay operates and latches in operating position when the measured value exceeds (or drops below) the set level for more than the set delay time.

Provided that the voltage has dropped below (or has exceeded) the set point (see hysteresis setting) the relay releases when the interconnection between terminals Z1, Y1 or 8, 9 is interrupted, or power supply is interrupted as well.

The red LED flashes until the delay time has expired or the measured value has dropped below the set point (see hysteresis setting).

Note

When the inhibit contact is opened, if the input signal is already in alarm position, the delay time needs to elapse before relay activation.

Function/Range/Level and Time Delay Setting

Adjust the input range setting the DIP switches 1 and 2 as shown below.

To access the DIP switches open the grey plastic cover as shown below.

Select the desired function setting the DIP switches 3 to 6 as shown below.

Selection of level and time delay:

Centre knob:
Voltage level setting on relative scale: 10 to 110% on full scale.

Upper knob:
Setting of hysteresis on relative scale: 0 to 30% on set value.

Lower knob:
Setting of delay on alarm time on absolute scale (0.1 to 30 s).

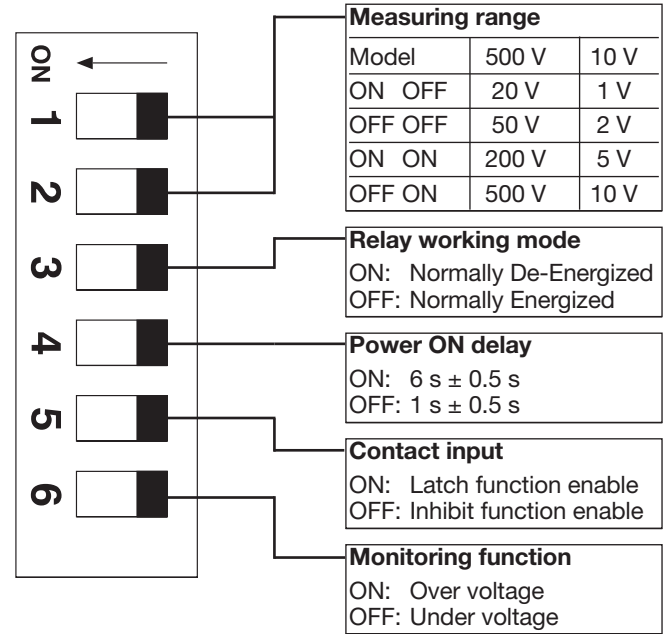
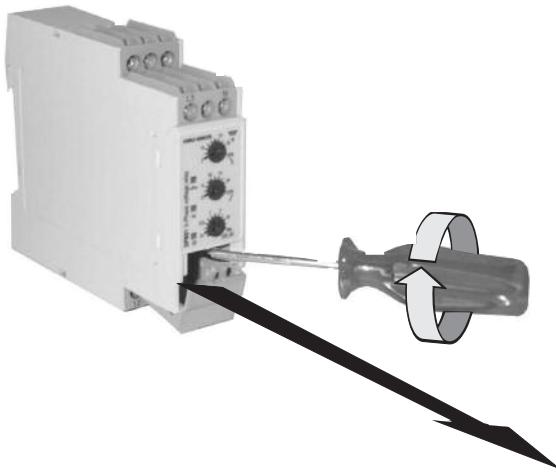

Wiring Diagrams

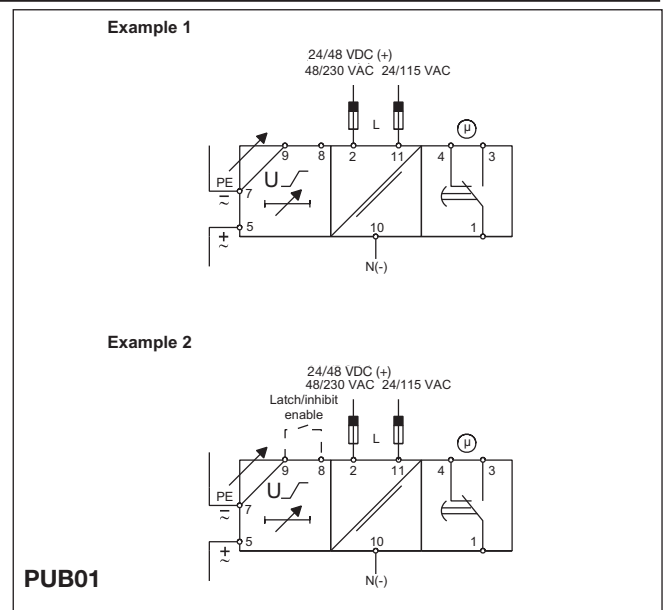
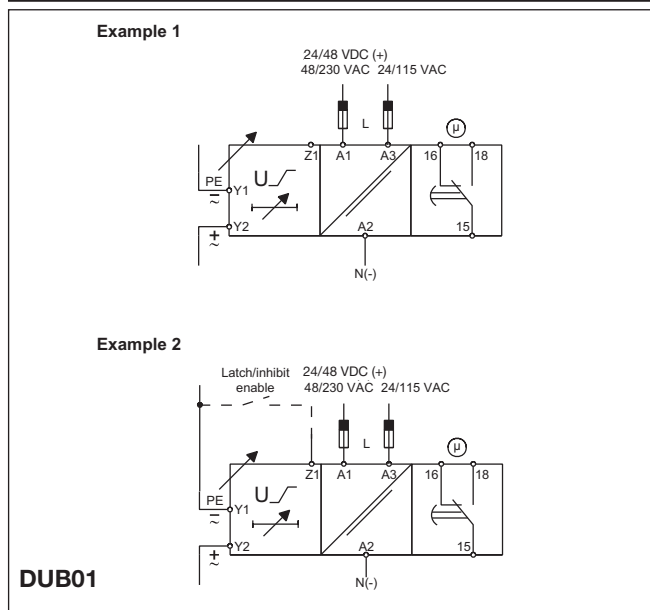

Operation Diagrams

Over voltage - N.D. relay

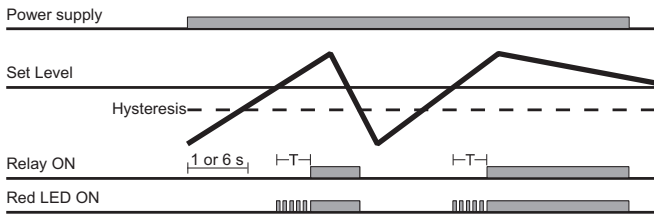

Under voltage - Latch function - N.D. relay

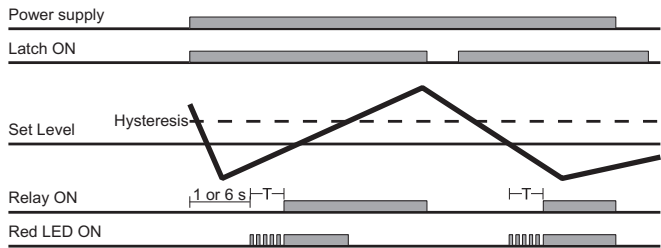

Under voltage - N.D. relay

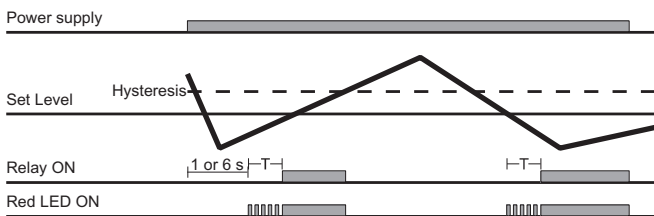

Over voltage - Inhibit function - N.D. relay

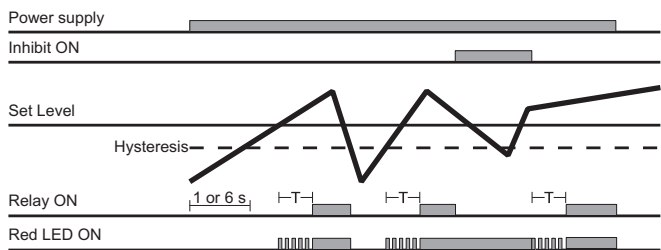

Dimensions

DIN-rail

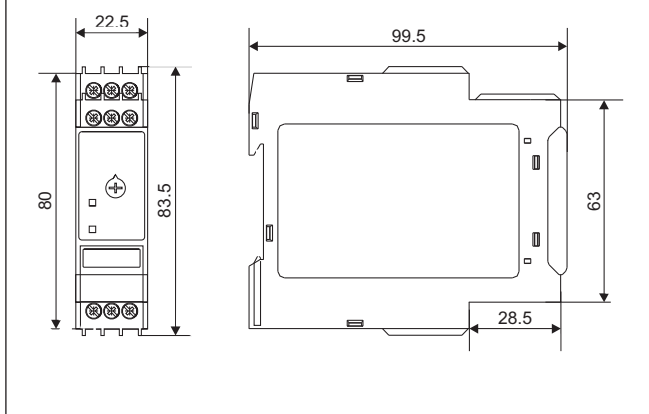

Plug-in

