

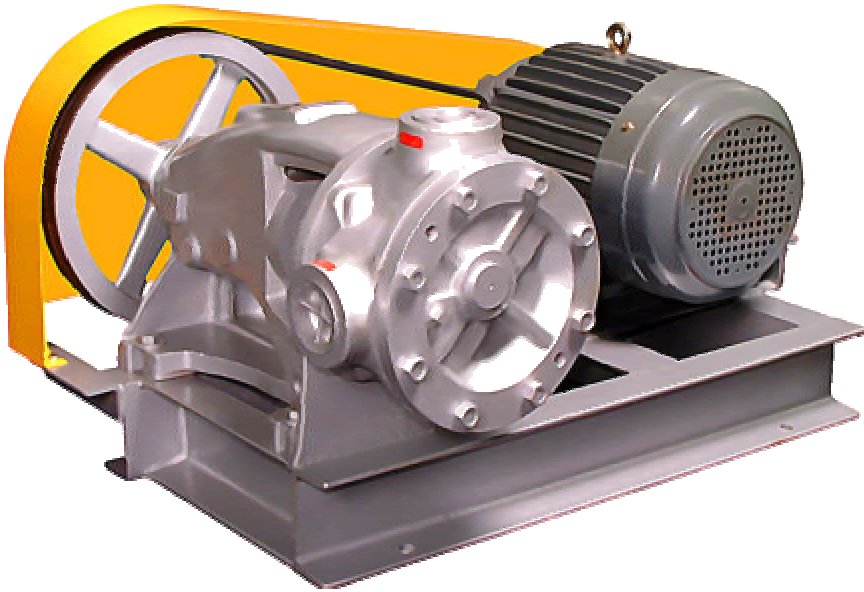

三錦齒輪式內轉齒輪泵

CAT-NO-30109
ISO-9001 認可登錄

IG



IGH

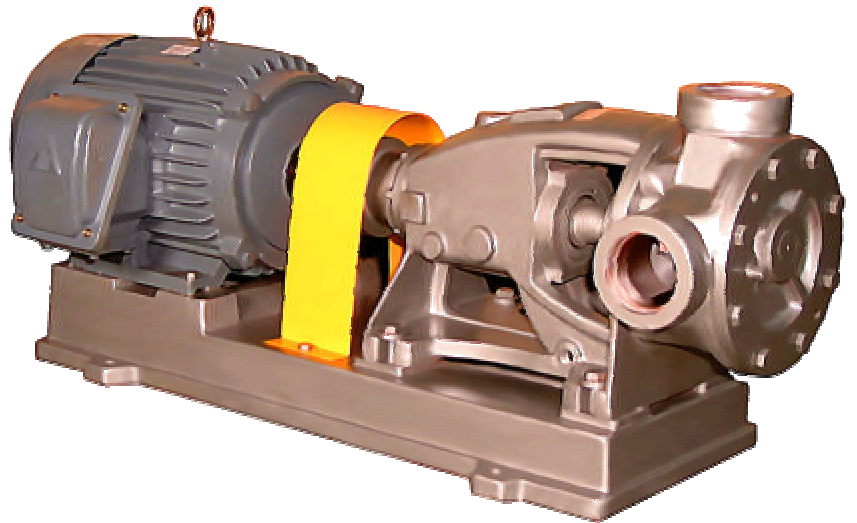

SUNNY-KING

INTERNAL GEAR PUMP

特點

吸力特強，最高可達 740mmHgG (20Torr)。
運送液體黏度最高可達 500000cps，最高壓力可達 30kg/cm²。
可根據需要加裝蒸氣套。
軸承與運送液體完全隔離，泵浦間隙可調整而不需分解。
輸送含固體微粒之固體可以內齒外軸形製造。
可改為機械軸封。

FEATURES

Suction is just as strong as vacuum pumps. Sunny King IG pump can pump mercury column reach so high as 740mmHgG (20Torr) .
The pump is capable of feeding any kind of liquid with low viscosity to high viscosity (500000cps). The pressure of this pump can reach 30 kg/cm².
Water heat jacket pump is also available upon special demand.
Bearing not exposed to liquid pumped. Can be taken up to compensate for normal wear. No need to dismantle pump for adjustment.
External bearing type of idler gear can be produced for handling grainy solid mixed liquid.
Easy movement of mechanical seal.

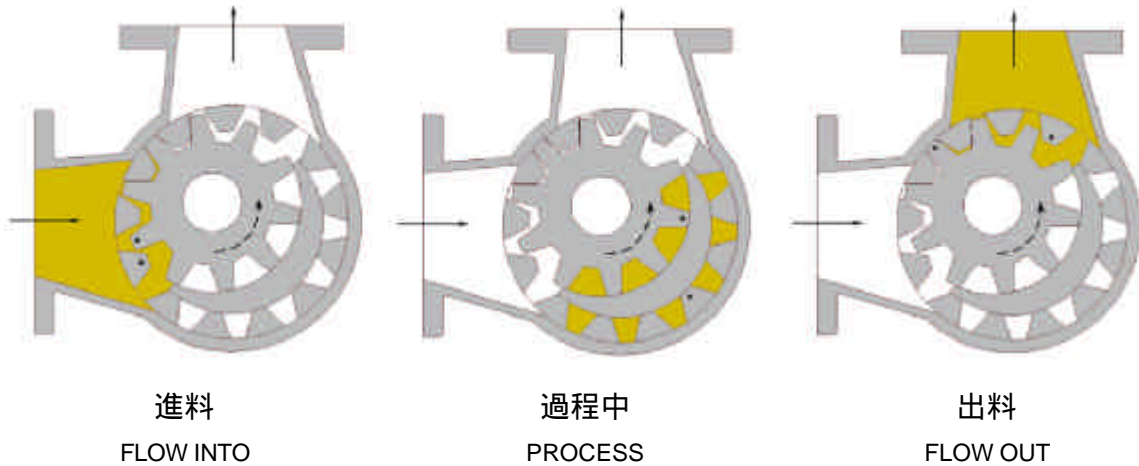

原理

三錦內轉式齒輪泵浦僅含兩轉動部分-主動齒輪及從動齒輪。當主動齒輪旋轉時，液體被吸入，充滿於半月形之內側及外側之齒隙間，均滑地送往出口。出口處齒隙間緊密齒合，以保持出口壓力。

HOW IT WORKS

SUNNY KING INTERNAL GEAR PUMP (IG) has only two moving parts a " gear-within-a-gear". See illustration at left. Power is on the rotor gear. As the gears unmesh, liquid is drawn into the pump. Filling the spaces between the gear teeth. Liquid moves smoothly around the crescent and is forced out at the discharge port by the meshing of the gear teeth, as indicated by direction arrows in diagram.

用途

食品：糖漿、醬油、果漿、牛奶、各種飲料。
石化工業：潤滑油脂、重油、瀝青。
化學產品：丙銅、乙醇、白明膠、DOP。
藥品：二氧化碳、氟氯烷、苯、氯化物。
塑膠及合成樹脂：苯乙烯、塑化劑。
塗料、瓷漆、泡沫、TDI、油漆。

APPLICATIONS

Foods : Syrup, Sauce, Jam, Milk, and other drink, etc.
Petroleum Industry : Grease-Lubricating, Heavy oil, Asphalt.
Chemical Products : Acetone, DOP, Ethyl Alcohol, Geltin.
Drugs : Carbon Disulfide, Freon, Benzene, Chloride.
Plastics & Synthetics : Solvents, Styrene, Plasticizer.
Paint, Enamel, Foam, TDI, Varnish.

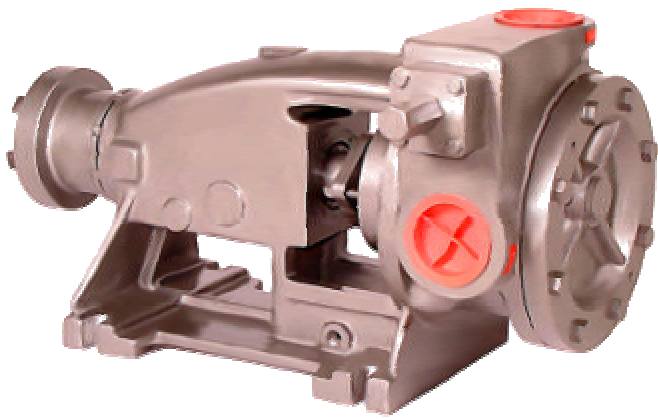

內藏式安全閥

當壓力過大時，液體可由安全閥回流，而不會損壞泵浦。

SAFETY RELIEF VALVE ON CASING

Safety relief valve permits by passing of liquid and prevents excessive pressure in the discharge line.

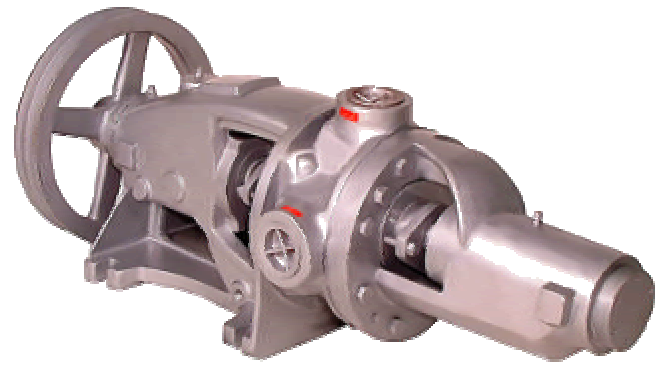

內齒外軸型

內齒軸承與液體完全隔絕，壽命特長，適合於含固體微粒或無潤滑性液體之運送。

EXTERNAL BEARING TYPE OF IDLE GEAR

Bearing of idle not exposed to liquid pumped. It can be produced for handling grainy solid mixed liquid and nonlubrication liquid.

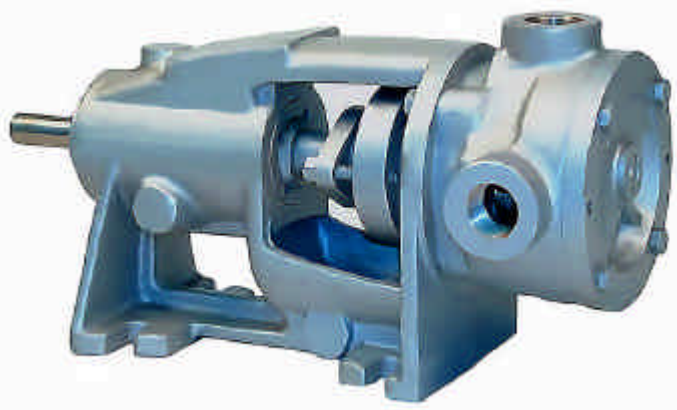

IG-1~6 , IGH-1~6



IG-1A , IG-2A , GI-3A , IGH-1A

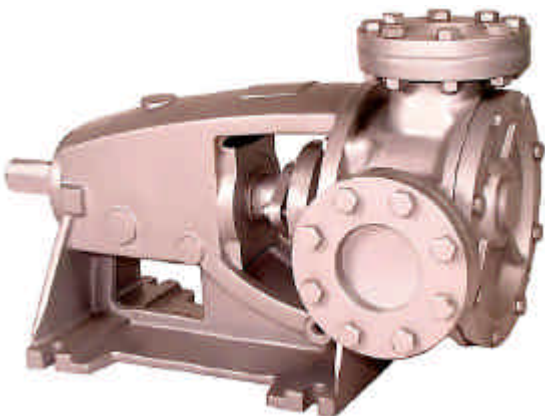

IG-7~10 , IGH-7~10



IGP-1~2

三錦內轉式齒輪泵浦試驗條件如下：

The performance of the Sunny king internal gear pump is indicated on the basis as follow :

吸入高 Suction height : 1m 溫度 Temperature : 20

試驗液體黏度 Tested liquid Viscosity : 150 cp

性能表

PERFORMANCE TABLE

型式 TYPE	口徑 (in) BORE	轉速 RPM	2 kg/cm ²		5 kg/cm ²	
			流量 l/min	馬力 HP	流量 l/min	馬力 HP
IG-1	0.5	550	11	0.5	9	1
IG-2	0.75	550	28	1	24	1
IG-3	1	500	48	1	42	2
IG-4	1.5	490	110	2	100	3
IG-5	2	450	170	3	155	5
IG-6	2.5	470	280	5	255	7.5
IG-7	3	410	450	7.5	420	10
IG-8	4	390	750	10	700	15
IG-9	5	380	1100	15	1020	25
IG-10	6	250	1500	20	1400	30

性能表

PERFORMANCE TABLE

型式 TYPE	口徑 (in) BORE	轉速 RPM	壓力 kg/cm ²	流量 l/min	馬力 HP
IGH-2	0.75	1750	6	47	2
IGH-3	1	1750	4	65	2
IGH-4	1.5	1750	4	120	3
IGH-5	2	1150	4	210	5
IGH-6	2.5	1150	4	360	7.5
IGH-7	3	1150	4	550	10
IGH-8	4	1150	4	1150	20
IGH-9	5	1150	4	1700	30
IGH-10	6	1150	4	2300	40

性能曲線

PERFORMANCE CURVE

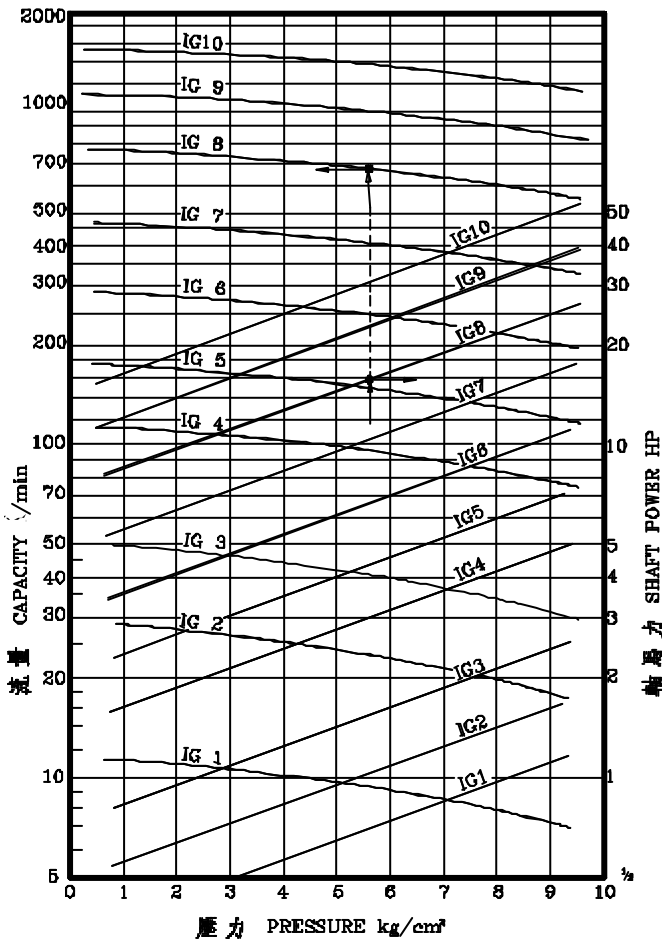

性能曲線

PERFORMANCE CURVE

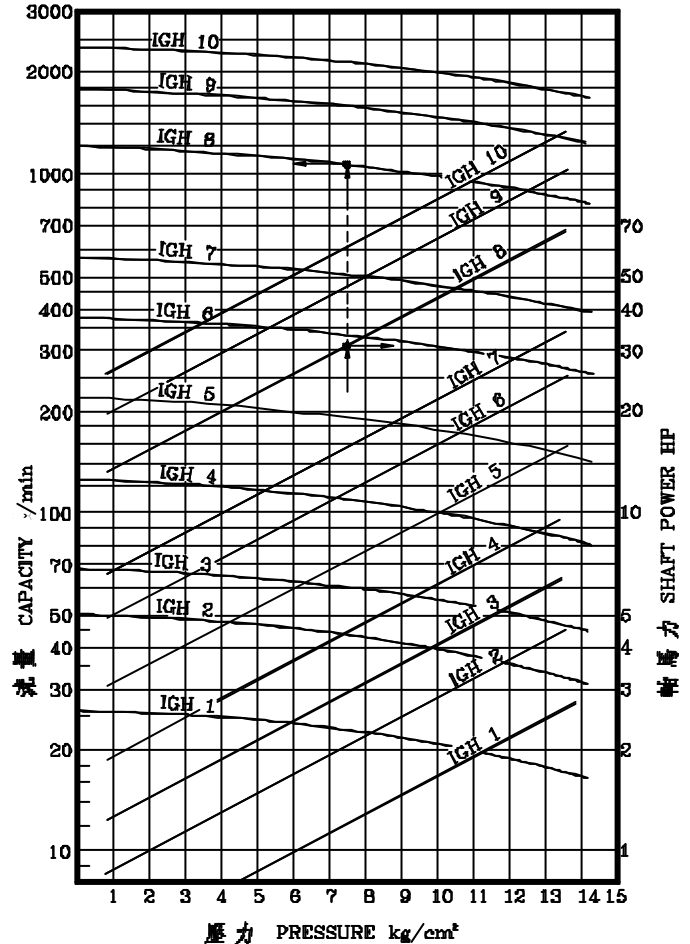

* 流量及轉速與輸送液體有關，當輸送高黏度液體時，轉速及流量需適當的降低。

* Capacities and speeds are based on pumping thin liquids. When pumping heavy viscous liquids, capacities and speeds should be reduced.

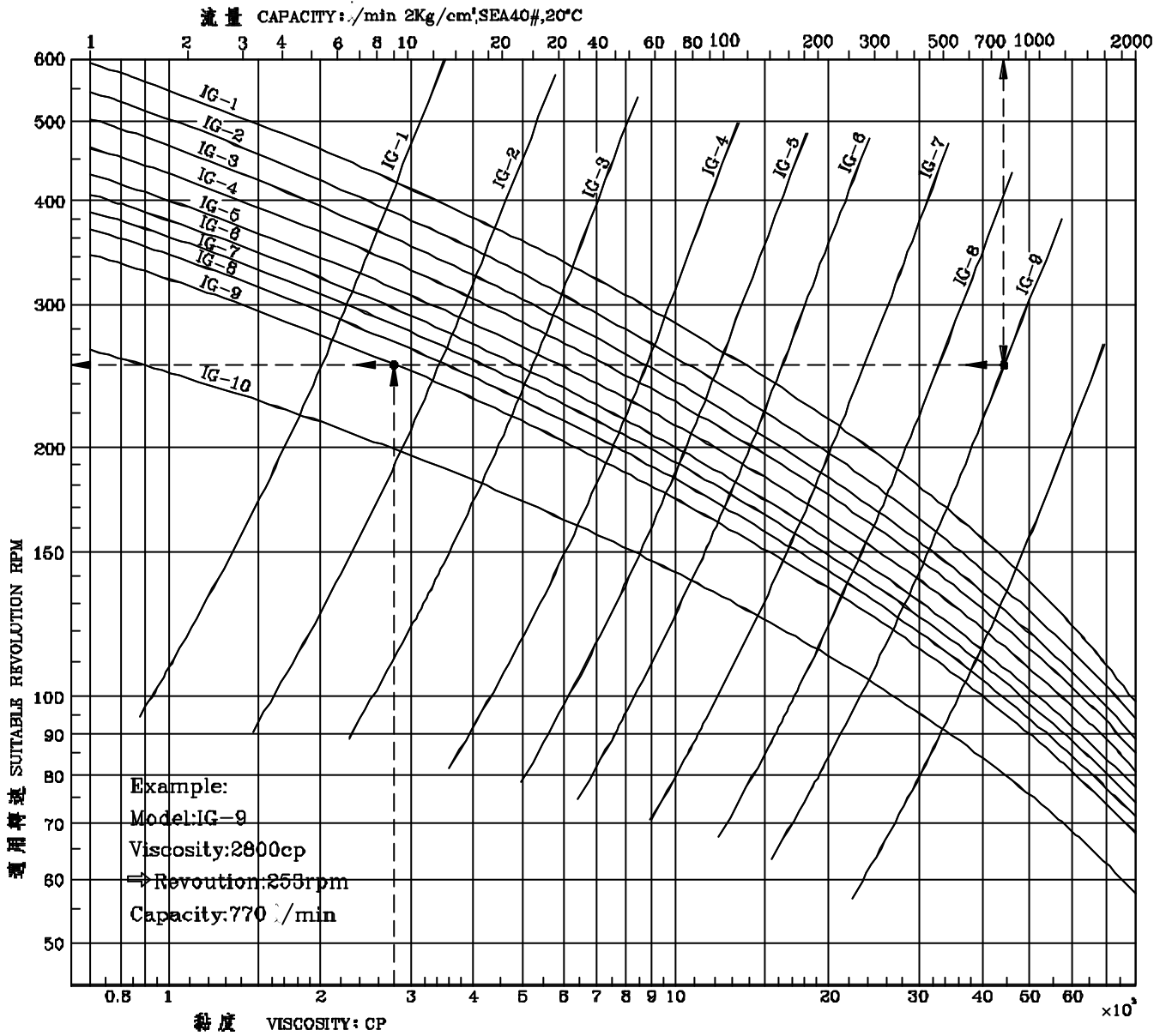

使用例 Service Example

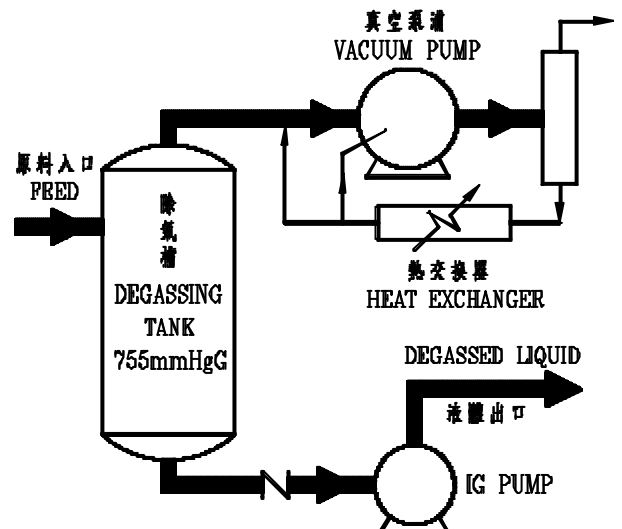
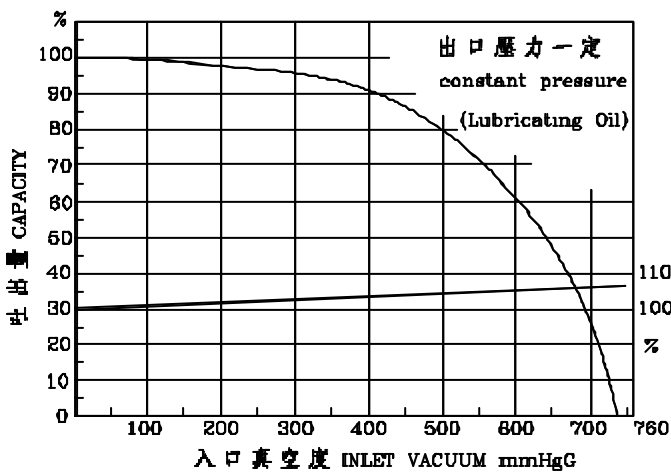

管路摩擦損失 m/100 m PIPE FRICTION LOSS m/100 m

New Schedule 40 Steel pipe

GPM (l/min)	管徑 Pipe Size	動黏度 Cst			Kinematic Viscosity-Cst										
		Water	20.6	43.2	65	87	110	132	176	220	330	440	660	1000	2000
3 (11.4)	0.5	10.0	25.7	54.4	83	108	135	162	218	273	411	545	820	1227	-
	0.75	2.50	8.5	17.5	26.7	35.5	44	53	71	88	131	176	265	400	800
	1	0.77	3.2	6.6	10.2	13.4	16.6	20.0	26.6	34	50	67	100	152	304
5 (18.9)	0.75	6.32	14.1	29.3	44	59	74	88	117	147	219	293	440	673	-
	1	1.93	5.3	11.0	16.8	22.4	28	33	44	56	83	111	167	253	506
	1.25	0.51	1.8	3.7	5.5	7.6	9.5	11.1	14.8	18.5	28	37	56	85	170
10 (37.9)	1	6.86	11.2	22.4	33.5	45	56	66	89	112	165	223	334.5	506.8	-
	1.25	1.77	3.6	7.5	11.2	14.9	19.1	22.4	30	37	55	74	112	173	346
	1.5	0.83	1.9	4.2	6.0	8.1	10.2	12.3	16.5	20.3	31	41	62	93	186
15 (56.8)	1	14.6	26	34	50	67	85	104	137	172	258	334	516	-	-
	1.25	3.72	6.4	11.3	16.9	22.4	29	34	45	57	84	112	167	253	506
	1.5	1.73	2.8	6.2	9.2	12.4	15.3	18.4	25	30	46	61	92	138	276
20 (75.7)	1	25.1	46	46	67	90	111	133	180	220	330	440	660	-	-
	1.5	2.94	5.3	8.1	12.2	16.2	20.3	25	33	40	61	81	122	185	370
	2	0.87	1.5	3.0	4.4	6.0	7.4	9.0	11.9	14.8	22.4	30	45	67	134
30 (114)	1.5	6.26	11.6	12.2	18.2	24.3	30	37	50	61	91	122	182	275.7	551.5
	2	1.82	3.2	4.4	6.7	9.0	11.1	13.2	17.8	22.2	33	45	67	101	202
	2.5	0.75	1.4	2.2	3.2	4.4	5.5	6.5	8.8	10.9	16.6	22.0	33	50	100
40 (152)	1.5	10.8	19.6	20.8	24	32	40	50	65	81	121	162	243	364	728
	2	3.10	5.8	5.8	9.0	11.8	14.8	17.7	24	30	44	59	89	135	270
	2.5	1.28	2.5	3.0	4.4	5.8	7.4	8.8	11.8	14.6	22.2	29	44	66	132
60 (227)	2	6.59	11.6	13.4	13.4	17.8	22.2	27	36	45	67	89	134	200	400
	2.5	2.72	5.1	5.5	6.5	8.8	10.9	13.1	17.8	22.0	34	44	66	99	198
	3	0.92	1.8	1.8	2.8	3.7	4.6	5.6	7.3	9.2	13.8	18.5	27	42	84
80 (303)	2.5	4.66	8.3	9.7	9.7	11.8	14.6	17.6	24	29	44	58	87	132	264
	3	1.57	3.0	3.2	3.7	4.8	6.2	7.3	9.7	12.2	18.3	24	37	55	110
	4	0.41	0.83	0.83	1.2	1.7	2.1	2.5	3.3	4.2	6.2	8.3	12.5	18.7	37.4
100 (389)	2.5	7.11	12.2	14.1	14.8	14.8	18.5	22	29	36	55	73	109	166	332
	3	2.39	4.4	5.1	5.1	6.2	7.6	9.1	12.1	16.2	23	31	46	70	140
	4	0.62	1.2	1.3	1.5	2.1	2.5	3.1	4.1	5.1	7.8	10.4	15.5	23.6	47.2
125 (473)	3	3.62	6.5	7.8	8.1	8.1	9.7	11.5	15.3	19.4	29	39	58	88	176
	4	0.94	1.8	2.1	2.1	2.6	3.2	3.9	5.2	6.4	9.8	12.7	19.3	29.1	58.2
	6	0.12	0.25	0.28	0.39	0.52	0.63	0.78	1.0	1.3	1.9	2.6	3.9	5.8	11.6
150 (568)	3	5.14	9.2	10.4	11.5	11.5	11.5	13.7	18.4	23	35	46	69	105	210
	4	1.32	2.4	2.9	2.9	3.1	3.9	4.6	6.2	7.8	11.5	15.4	23	35.5	71
	6	0.18	0.34	0.39	0.46	0.62	0.77	0.9	1.2	1.5	2.3	3.0	4.6	6.9	13.8
175 (662)	3	6.9	11.7	13.8	15.8	15.8	15.8	15.9	21.4	27	40	53	80	121	242
	4	1.76	3.2	4.0	4.0	4.0	4.6	5.4	7.4	9.2	13.7	18.2	28	42	84
	6	0.23	0.44	0.52	0.54	0.7	0.9	1.1	1.4	1.8	2.6	3.5	5.3	8	16
200 (757)	3	8.90	15.0	17.8	20.3	20.3	20.3	20.3	25	31	46	61	91	138	276
	4	2.27	4.2	5.1	5.1	5.1	5.1	6.2	8.3	10.4	15.5	20.6	31	46	92
	6	0.30	0.58	0.69	0.69	0.81	1.0	1.2	1.6	2.0	3.0	3.9	6.2	9	18
250 (946)	4	3.46	6.0	7.4	8.0	8.0	8.0	8.0	10.2	12.9	19.4	26	39	58	116
	6	0.45	0.83	0.99	1.0	1.0	1.2	1.5	2.1	2.5	3.7	5.1	7.6	11.4	22.8
	8	0.12	0.21	0.28	0.28	0.35	0.42	0.51	0.67	0.83	1.2	1.7	2.5	3.8	7.6
300 (1136)	4	4.98	8.5	9.9	11.6	11.6	11.6	11.6	12.4	15.5	23	31	46	70	140
	6	0.64	1.2	1.4	1.5	1.5	1.5	1.8	2.5	3.0	4.6	6.0	9.1	13.6	27.2
	8	0.16	0.30	0.39	0.39	0.42	0.51	0.61	0.82	1.0	1.5	2.0	3.0	4.6	9.2
400 (1514)	6	1.09	1.9	2.3	2.5	2.8	2.8	2.8	3.2	3.9	6.0	8.1	12.1	18.3	36.6
	8	0.28	0.53	0.62	0.67	0.67	0.67	0.81	1.1	1.3	2.0	2.8	4.1	6.1	12.2
	10	0.09	0.18	0.21	0.23	0.23	0.28	0.32	0.43	0.53	0.81	1.1	1.6	2.5	5
600 (2270)	6	2.34	4.2	5.1	5.3	5.5	6.0	6.2	6.2	6.2	9.0	12.0	18.5	28	56
	8	0.60	1.1	1.3	1.4	1.6	1.5	1.5	1.7	2.0	3.0	3.9	6.2	9	18
	10	0.19	0.37	0.42	0.46	0.51	0.51	0.51	0.65	0.81	1.2	1.6	2.4	3.8	7.2
800 (3030)	6	4.03	6.5	8.1	8.5	9.2	9.7	11.1	11.1	11.1	12.0	16.0	24	36.4	72.8
	8	1.02	1.8	2.2	2.3	2.5	2.8	2.8	2.8	2.8	3.9	5.3	8.2	12.2	24.4
	10	0.33	0.60	0.69	0.78	0.88	0.92	0.92	0.92	1.1	1.6	2.1	3.2	4.8	9.6

1 Cst = 4.635 SSU = 1 cp/spgr

構造圖 Construction :

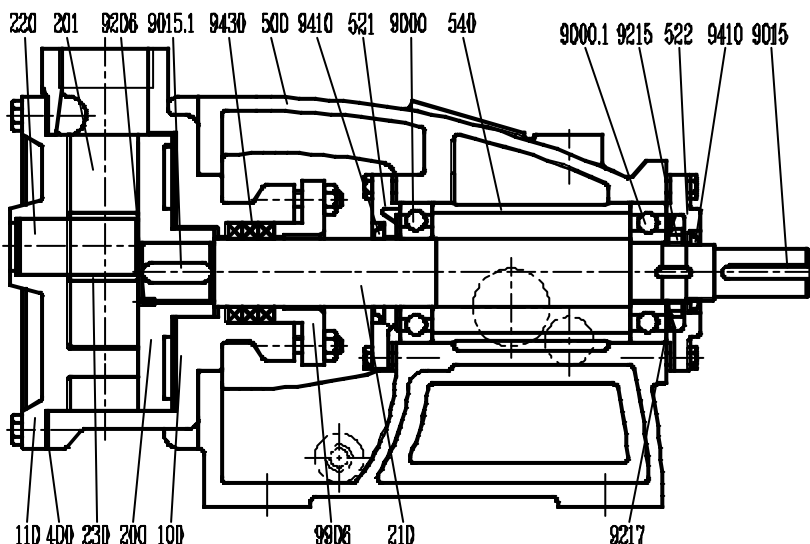

NO	名稱	PARTS NAME
100	機殼	CASING
110	邊蓋	COVER
200	主動齒輪	DRIVING GEAR
201	從動齒輪	DRIVEN GEAR
210	軸	SHAFT
220	固定軸	FIXED SHAFT
230	襯套	BUSHING
400	墊片	GASKET
500	軸承座	BEARING BRACKET
521	非傳動側軸承蓋	BEARING COVER
522	傳動側軸承蓋	BEARING COVER
540	軸承套筒	SLEEVE
9000	軸承	BEARING
9000.1	軸承	BEARING
9015	鍵	KEY
9015.1	鍵	KEY
9206	內六角固定螺絲	SET SCREW
9215	固定螺帽	LOCKNUT
9217	軸承固定墊圈	WASHER
9410	擋水環	V-RING
9430	填料	PACKING
9906	填料蓋	GLAND

IG 型外型尺寸圖 Dimension

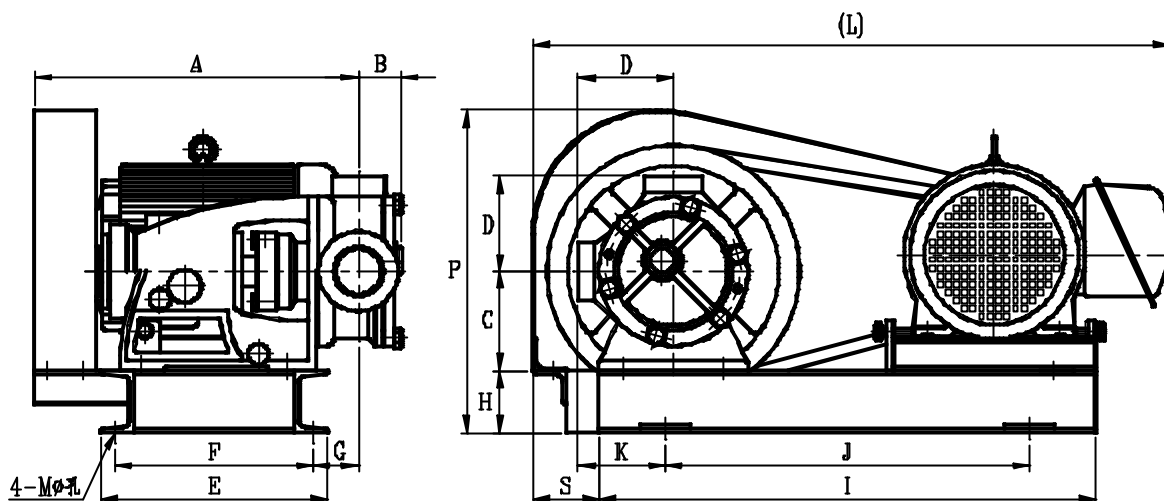

型式 TYPE	口徑 (in) BORE	A	B	C	D	E	F	G	H	I	J	K	L	M	P	S	備註
IG-1	0.5pt	327	31	100	70	195	110	79	32	508	475	27	567	11	262	67	
IG-2	0.75pt	332	44	100	73	195	110	83	32	508	475	30	567	11	262	67	
IG-3	1pt	348	53	112	85	230	132	93	40	508	484	27	582	11	320	82	
IG-4	1.5pt	390	53	120	115	275	240	52	75	600	440	105	680	15	390	80	
IG-5	2pt	490	67	160	140	360	325	38	100	700	500	123	765	15	430	109	
IG-6	2.5pt	567	76	180	165	400	360	59	100	760	560	135	860	15	480	128	
IG-7	3pt	617	82	200	185	420	360	112	125	880	630	167	955	19	550	115	
IG-8	4pt	712	96	240	205	540	480	55	125	950	700	177	1042	19	615	147	
IG-9	5pt	708	136	240	240	540	480	45	125	950	700	217	1045	19	625	153	
IG-10	6pt	911	175	320	285	675	600	78	150	1200	800	310	1417	23	960	195	

IGH 型外型尺寸圖 Dimension

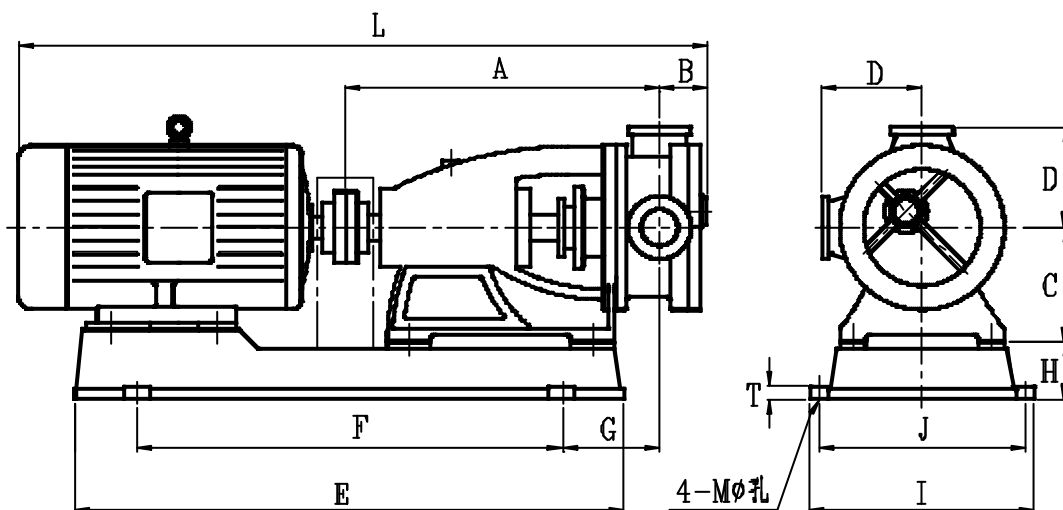

型式 TYPE	口徑 (in) BORE	馬力 HP	轉速 rpm	A	B	C	D	E	F	G	I	J	L	M	T	備註
IGH-1	0.5pt	1	1750	309	29	100	70	520	304	130	230	200	611	11	15	
IGH-2	0.75pt	2	1750	312	36	100	75	565	362	125	260	230	671	11	15	
IGH-3	1pt	2	1750	311	44	100	85	565	362	124	260	230	678	11	15	
IGH-4	1.5pt	3	1750	335	51	112	100	620	400	139	280	250	752	11	20	
IGH-5	2pt	5	1150	370	53	120	125	645	425	140	320	290	872	15	20	
IGH-6	2.5pt	7.5	1150	458	77	160	150	808	564	157	355	312	1023	15	20	
IGH-7	3pt	10	1150	534	91	180	165	989	578	264	412	370	1234	19	25	
IGH-8	4pt	20	1150	594	99	200	185	1100	823	206	482	440	1365	19	20	

請提供下列事項，以便本公司為您選擇最合適的泵浦。

操作條件：容量，出口及入口壓力。

液體性質：酸、鹼、溫度、比重、黏度及其他特性。

擬用馬力。

動力傳達方式。

構造材質：鑄鐵、鑄鋼、不銹鋼、耐蝕合金。

Please let us have the following information when inquiring, with are needed to offer an optimum pump

Optimum condition : Capacity, suction and discharge pressure.

Liquid quality : Acid, alkaline, temperature, specific gravity viscosity and other properties.

Required horsepower.

Power transmission method.

Materials : Cast iron, Cast steel, Stainless steel, Alloy 20 CD4MCU Hastelloys, Monel available.

其他產品

真空泵浦

水封式真空泵浦

往復式真空泵浦

無油式真空泵浦

老達利真空泵浦

機械式助力泵浦

高真空泵浦系統

液體泵浦

衛生泵浦

內轉式齒輪泵浦

人字型齒輪泵浦

離心泵浦

標準化離心泵浦

無軸封離心泵浦

高溫泵浦

同軸泵浦

自吸式離心泵浦

水壓試驗機

魯式鼓風機、真空泵浦

OTHER PRODUCTS

VACUUM PUMP

Liquid Ring Vacuum Pump

Reciprocating Vacuum Pump

Oilless Vacuum Pump

Rotary Vacuum Pump

Mechanical Booster

High Vacuum System

LIQUID PUMP

Sanitary Pump

Internal Gear Pump

Herringbone Gear Pump

CENTRIFUGAL PUMP

Stand Centrifugal Pump

Sealless Pump

Close-Coupled Pumps

High Temperature Pumps

Self-Priming Process Pumps

WATER PRESSURE TEST PUMP

ROOTS BLOWER, VACUUM PUMP

本型錄如有變更時，恕不另行通知，訂購時請先確認 Any changes in the interest of the technical development are reserved

上海伊旋机械设备有限公司

地址：上海市闵行区莘松路958弄21号1501室

电话：021-61247861

传真：021-61247862