

Application Note of SMD802

Universal High Brightness LED Driver

FEATURES

- _ > 90% Efficiency
- _ Universal rectified 85 – 265V_{AC} input range
- _ Constant-current LED driver
- _ Applications from a few mA to more than 1A Output
- _ LED string from one to hundreds of diodes
- _ PWM Low-Frequency Dimming via Enable pin
- _ Input Voltage Surge ratings up to 500V
- _ Internal thermal overload protection

APPLICATIONS

- _ AC/DC LED Driver applications
- _ RGB Backlighting LED Driver
- _ Back Lighting of Flat Panel Displays
- _ General purpose constant current source
- _ Signage and Decorative LED Lighting
- _ Chargers

1. Demo board circuit for E-27 :

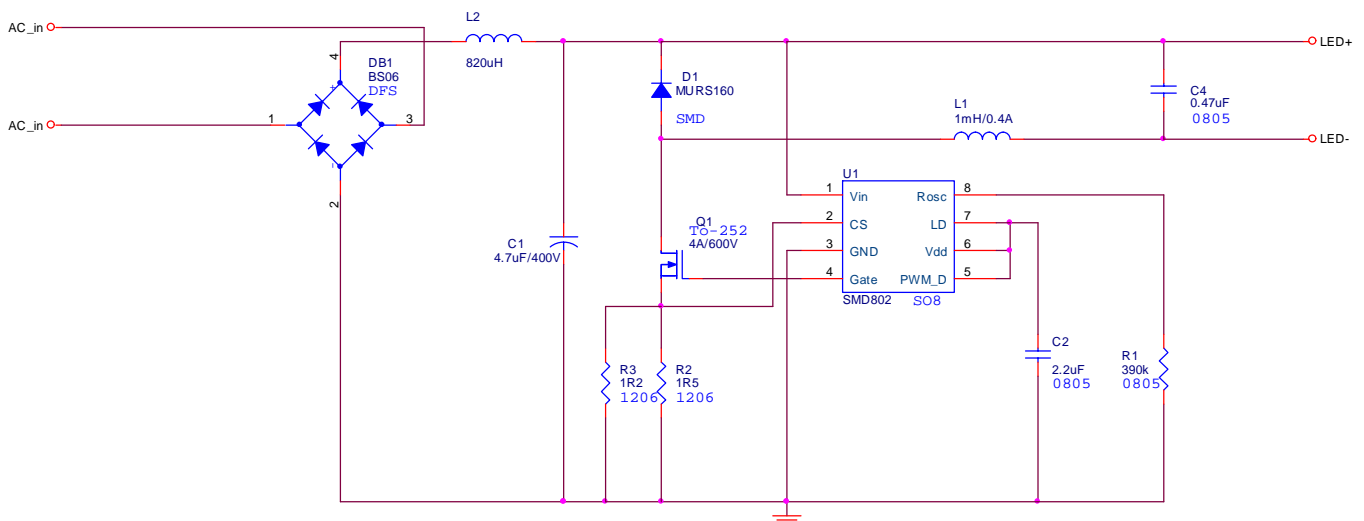

Note : R1 shall be 820K Ω ~1M Ω for the case of V_{out} < 7V because it has to satisfy the condition of T_{on} > T_{BLANK}. The efficiency can be improved as well.

Application Note of SMD802

2. BOM :

Item	Quantity	Reference	Part
1	1	C1	4.7uF/400V
2	1	C2	2.2uF
3	1	C4	0.47uF
4	1	DB1	BS06
5	1	D1	MURS160
6	1	L1	4.7mH/0.4A
7	1	L2	820uH
8	1	Q1	4A/600V
9	1	R1	390K
10	1	R2	1R5
11	1	R3	1R2
12	1	U1	SMD802

3. PCB Layout :

Top-Silkscreen

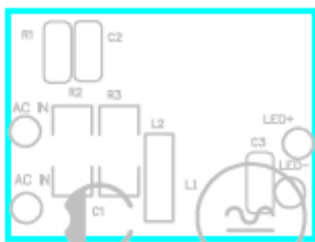

Top-side



Bottom-Silkscreen

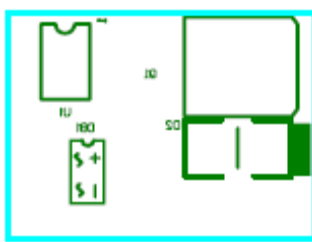

Bottom-side

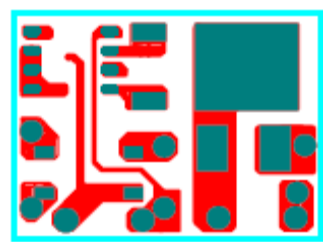

Application Note of SMD802

4. Critical Inductance :

The buck power stages have been for continuous and discontinuous conduction modes of steady-state operation. The conduction mode of a power stage is a function of input voltage, output voltage, output current, and the value of the inductor. A buck power stage can be designed to operate in continuous mode for load currents above a certain level usually 15% to 30% of full load. Usually, the input voltage range, the output voltage and load current are defined by the power stage specification. This leaves the inductor value as the design parameter to maintain continuous conduction mode.

The minimum value of inductor to maintain continuous conduction mode can be determined by the following procedure.

Equation :

$$D = \frac{V_{LEDs(VF)}}{V_{in}}$$

$$T_{on} = \frac{D}{F_{osc}}$$

$$L \geq \frac{(V_{in} - V_{LEDs(VF)}) \times T_{on}}{0.3 \times I_{LED}}$$

$$R_{sense} = \frac{0.25}{I_{LED} + (0.5 \times (I_{LED} \times 0.2))}$$

$$F_{osc} = \frac{25000}{R_{osc} + 22}$$

5. Input Capacitance :

An input filter capacitor should be designed to hold the rectified AC voltage above twice the LED string voltage throughout the AC line cycle. Assuming 15% relative voltage ripple across the capacitor, a simplified formula for the minimum value of the bulk input capacitor is given by :

Equation :

$$C_{in} \geq \frac{P_{in} \times (1 - D_{ch})}{\sqrt{2V_{Line_min}} \times 2f_L \times \Delta V_{DC_max}}$$

Among them D_{ch} is that C_{in} capacity charges work period, it is generally about 0.2~0.25, f_L is input frequency, at input the full range voltage(85~265 V_{rms}), ΔV_{DC_max} should be set 10~15% of $\sqrt{2V_{Line_min}}$.

Application Note of SMD802

6. Dimming control :

This terminal can be used to either enable/disable the converter or to apply a PWM dimming signal.

To just enable the converter, connect the PWMD pin to the V_{DD} pin.

Disconnecting the PWMD pin will cause the circuit to stop.

PWM dimming of the LED light can be achieved by turning on and off the converter with low frequency 50Hz to 1000Hz TTL logic level signal.

Changing the Duty Ratio of the signal changes the effective average current via the LEDs, changing the light emission.

Note : In the case of PWM dimming, the PWM_D pin should not be connected to the V_{DD} pin!

Also, the signal generator or the device applying the signal to PWM_D pin must be isolated from the input mains.